

Mini-RWIS PILOT PROJECT

(2020 – 2022)

A public-private partnership demonstration project between Campbell Scientific, Inc. and the Alaska Department of Transportation & Public Facilities in collaboration with the University of Alaska Fairbanks (Institute of Northern Engineering) and Geo-Watersheds Scientific.

FINAL PROJECT REPORT

by

Kevin Randall, MSc
Campbell Scientific, Inc.

and

Billy Connor, Richard Weiss, and Elycia Cormier
University of Alaska Fairbanks
Institute of Northern Engineering

for

Alaska Department of Transportation & Public Facilities
4111 Aviation Avenue, Anchorage, AK 99519

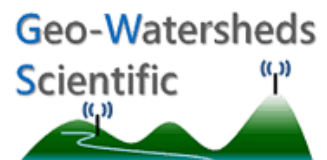

Technical Report Documentation Page

1. Report No. FHWA-AK-RD-000S(936)		2. Government Accession No.		3. Recipient's Catalog No.	
4. Title and Subtitle Mini-RWIS PILOT PROJECT (2020 – 2022) A public-private partnership demonstration project between Campbell Scientific, Inc. and the Alaska Department of Transportation & Public Facilities in collaboration with the University of Alaska Fairbanks (Institute of Northern Engineering) and Geo-Watersheds Scientific.				5. Report Date August 2022	
				6. Performing Organization Code	
7. Author(s) and Affiliations Kevin Randall, MSc, Campbell Scientific, Inc. Billy Connor, Richard Weiss, and Elycia Cormier, University of Alaska Fairbanks, Institute of Northern Engineering				8. Performing Organization Report No. FHWA-AK-RD-000S(936) HFHWY00204	
9. Performing Organization Name and Address Institute of Northern Engineering, Arctic Infrastructure Development Center ELIF Building Room 240, 1760 Tanana Drive Fairbanks, AK 99775-5910				10. Work Unit No. (TRAIS)	
				11. Contract or Grant No.	
12. Sponsoring Organization Name and Address United States Department of Transportation Research and Innovative Technology Administration 1200 New Jersey Avenue, SE Washington, DC 20590				13. Type of Report and Period Covered	
				14. Sponsoring Agency Code	
15. Supplementary Notes Report uploaded to:					
16. Abstract In 2019, Campbell Scientific, a manufacturer of research-grade data acquisition systems entered a public/private partnership project with the Alaska Department of Transportation and Public Facilities (ADOT&PF) to demonstrate the scalable (mini) Road Weather Information System (RWIS) concept. This partnership included research personnel from the University of Alaska Fairbanks (UAF) to assess the performance of the mini-RWIS stations with the goal of providing feedback to ADOT&PF regarding the performance of the stations and the feasibility of adding the mini-RWIS station concept as a cost-effective option for of filling gaps in the Alaskan RWIS network. Seven standard mini-RWIS stations were assessed based on the performance of the atmospheric sensor data (including wind speed and direction, air temperature and relative humidity, and road surface temperature), reliable delivery of camera images, power performance, and cellular communication performance. They performed well throughout the study and results show that a Public/Private Partnership with emerging technologies can be a positive avenue to pilot systems to use within DOT system where performance is unknown at the time of trial.					
17. Key Words Road Weather Information Systems, Maintenance, proof of concept, innovation, RWIS, public private partnership, sensor data				18. Distribution Statement	
19. Security Classification (of this report) Unclassified.		20. Security Classification (of this page) Unclassified.		21. No. of Pages 78	22. Price N/A

SI* (Modern Metric) Conversion Factors

APPROXIMATE CONVERSIONS TO SI UNITS				
Symbol	When You Know	Multiply By	To Find	Symbol
LENGTH				
in	inches	25.4	millimeters	mm
ft	feet	0.305	meters	m
yd	yards	0.914	meters	m
mi	miles	1.61	kilometers	km
AREA				
in ²	square inches	645.2	square millimeters	mm ²
ft ²	square feet	0.093	square meters	m ²
yd ²	square yard	0.836	square meters	m ²
ac	acres	0.405	hectares	ha
mi ²	square miles	2.59	square kilometers	km ²
VOLUME				
fl oz	fluid ounces	29.57	milliliters	mL
gal	gallons	3.785	liters	L
ft ³	cubic feet	0.028	cubic meters	m ³
yd ³	cubic yards	0.765	cubic meters	m ³
NOTE: volumes greater than 1000 L shall be shown in m ³				
MASS				
oz	ounces	28.35	grams	g
lb	pounds	0.454	kilograms	kg
T	short tons (2000 lb)	0.907	megagrams (or "metric ton")	Mg (or "t")
TEMPERATURE (exact degrees)				
°F	Fahrenheit	5 (F-32)/9 or (F-32)/1.8	Celsius	°C
ILLUMINATION				
fc	foot-candles	10.76	lux	lx
fl	foot-Lamberts	3.426	candela/m ²	cd/m ²
FORCE and PRESSURE or STRESS				
lbf	poundforce	4.45	newtons	N
lbf/in ²	poundforce per square inch	6.89	kilopascals	kPa
APPROXIMATE CONVERSIONS FROM SI UNITS				
Symbol	When You Know	Multiply By	To Find	Symbol
LENGTH				
mm	millimeters	0.039	inches	in
m	meters	3.28	feet	ft
m	meters	1.09	yards	yd
km	kilometers	0.621	miles	mi
AREA				
mm ²	square millimeters	0.0016	square inches	in ²
m ²	square meters	10.764	square feet	ft ²
m ²	square meters	1.195	square yards	yd ²
ha	hectares	2.47	acres	ac
km ²	square kilometers	0.386	square miles	mi ²
VOLUME				
mL	milliliters	0.034	fluid ounces	fl oz
L	liters	0.264	gallons	gal
m ³	cubic meters	35.314	cubic feet	ft ³
m ³	cubic meters	1.307	cubic yards	yd ³
MASS				
g	grams	0.035	ounces	oz
kg	kilograms	2.202	pounds	lb
Mg (or "t")	megagrams (or "metric ton")	1.103	short tons (2000 lb)	T
TEMPERATURE (exact degrees)				
°C	Celsius	1.8C+32	Fahrenheit	°F
ILLUMINATION				
lx	lux	0.0929	foot-candles	fc
cd/m ²	candela/m ²	0.2919	foot-Lamberts	fl
FORCE and PRESSURE or STRESS				
N	newtons	0.225	poundforce	lbf
kPa	kilopascals	0.145	poundforce per square inch	lbf/in ²

*SI is the symbol for the International System of Units. Appropriate rounding should be made to comply with Section 4 of ASTM E380.
(Revised March 2003)

Table of Contents

Executive Summary	1
Introduction	3
Site Selection	5
Equipment Used	6
UAF Cold Room Testing	6
System Modifications	7
Atigun Pass Project Integration	8
Summary of data	9
Atmospheric & Road Surface Parameters	9
Images	10
Power	11
Cellular Communications and Campbell Cloud	12
Installations and Maintenance	12
Summary & Conclusions	13
Recommendations	14
Acknowledgements	15
Appendix A: UAF Report	1
EXECUTIVE SUMMARY	1
INTRODUCTION AND RESEARCH APPROACH	2
Problem Statement and Objective	2
Scope of Study and Approach	2
SETUP AND PROCEDURE	3
Cold Room Testing	3
Site Installations	3
RESULTS AND DATA ANALYSIS	4
Cold Room Testing Analysis	4
Site Data Analysis	5
<i>Chena Hot Springs MP 10 (Logger 302)</i>	6
<i>Seward Highway MP 113.4 (Logger 301)</i>	9
<i>Seward Highway MP 98.5 (Logger 304)</i>	12
<i>Comparison: Seward Highway MP 98.5 and MP 113.4 RWIS Meteorological Data</i>	15
<i>Alaska Highway MP 1285 (Logger 202)</i>	17

<i>Tok Cutoff MP 18.5 (Logger 101)</i>	20
<i>Glenn Highway MP 106 (Logger 201)</i>	24
<i>Hatcher Pass MP 15 (Logger 303)</i>	27
GENERAL OBSERVATIONS	30
SUMMARY OF RESULTS AND CONCLUSIONS	30
Appendix B: Station Locations and Station Design Schematics	1
Appendix C: Site Photos	1

Executive Summary

Campbell Scientific in partnership with ADOT&PF successfully demonstrated the use of a low-power, low-cost, small-footprint, mini-RWIS concept in Alaska that could reliably deliver atmospheric and road temperature data as well as camera images year-round. The project originally was conceived to demonstrate eight mini-RWIS stations. ADOT&PF personnel performed site selection.

Of the eight mini-RWIS initially conceived for this demonstration project seven mini-RWIS stations were successfully deployed at selected sites in DOT Northern and South-Central regions. The eighth station was incorporated into a University of Alaska project at Atigun Pass that was designed to provide data, forecasting and warning for avalanche risks on the Dalton Highway. The system utilized multiple cameras, blowing snow sensors, as well as other atmospheric sensors on a solar panel/battery system. This station at Atigun Pass should be considered a step above the mini-RWIS concept and is, by far, the northern-most advanced RWIS station deployed in the state of Alaska providing data in an area where the climate conditions are extreme. As such, the station requirements were designed to withstand, high winds, temperatures below -40°F, the potential for rime ice, two months without sunlight, and lack of cellular connectivity. Consequently, the location challenged the equipment.

Campbell Scientific initially shipped all equipment to Alaska in the spring of 2019 to be cold chamber tested at the University of Alaska Fairbanks (UAF), then installed in the field prior to the winter season. Cold chamber testing was successfully accomplished, however, due to a variety of delays these stations were not installed prior to the 2019/2020 winter season.

In March of 2020, the global COVID-19 pandemic prevented Campbell Scientific personnel from traveling and installing stations during the summer of 2020. Instead, Campbell Scientific reached out to a long-time user of CS equipment, Michael Lilly of Geo-Watersheds Scientific (GWS), in Fairbanks, AK. Michael and his team have decades of experience in the design of low-power data acquisition systems and networks (including power system design, programming, installation, and maintenance) with specialization in remote hydrological and meteorological monitoring stations. The GWS team set out to understand the needs of the project and immediately became fully invested. As a result, the mini-RWIS system design went through a modification process per the recommendations of the GWS team. Campbell Scientific work with GWS to affect the following changes to the mini-RWIS:

- Expansion of battery bank considering the long Alaskan winters
- Addition of CH200 regulator for the purpose of gathering critical information on the performance of the power system.
- Addition of a fiberglass enclosure for the purpose of protecting cables from wildlife during winter months when food sources are depleted.
- Reprogramming of dataloggers to meet project goals
- Configuration of CCFC camera for optimization of power requirements.

GWS was contracted by CSI with approval from ADOT&PF (Contract # 2520H016 Amendment #1) to utilize GWS' services for installation of two stations during the winter of 2020/2021. ADOT&PF personnel also installed one station during the winter of 2020/2021.

Campbell Scientific personnel traveled to Alaska for two weeks during September of 2021 to install the remaining four mini-RWIS stations prior to the 2021/2022 winter season. Maintenance was performed on the three previously installed stations during that trip.

Project update meetings were held between CSI, ADOT&PF, UAF, and GWS prior to the 2021/2022 winter season with additional performance review meetings in January 2022 to discuss station performance.

CSI personnel additionally traveled to Alaska during July 2022 to visit project stakeholders in Anchorage and Fairbanks and to visit each of the seven mini-RWIS stations to perform general maintenance.

In total seven mini-RWIS stations were installed between the northern and central regions in Alaska. The equipment (datalogger, sensors, power system, enclosures, etc.) from the eighth mini-RWIS station, with the support of ADOT&PF, was repurposed for a project being done by UAF personnel with the support of GWS. The CR300 datalogger (embedded in the mini-RWIS stations) was upgraded to the higher capacity CR1000X due to the need for additional sensor inputs, and additional sensors were used including two blowing snow sensors and an additional wind speed and direction sensor, an extreme-cold temperature sensor and snow depth, and snow temperature profile sensors.

The seven standard mini-RWIS stations were assessed based on the performance of the atmospheric sensor data (including wind speed and direction, air temperature and relative humidity, and road surface temperature), reliable delivery of camera images, power performance, and cellular communication performance. The performance of the advanced winter-hazards RWIS was performed by the Atigun Pass project.

Throughout the study period atmospheric data proved to be within an acceptable and expected range, was reliable and was recorded without failures. Camera images were reliable and delivered in a timely manner over the cellular network. The power performance proved to be very robust and more than sufficient for the power needs of the mini-RWIS stations. Cellular communications proved reliable. Several minor instances of loss of cellular connectivity were encountered but cellular connection was regained quickly and self-corrected.

Introduction

In 2019, Campbell Scientific, a manufacturer of research-grade data acquisition systems entered a public/private partnership project with the Alaska Department of Transportation and Public Facilities (ADOT&PF) to demonstrate the scalable (mini) Road Weather Information System (RWIS) concept. This partnership included research personnel from the University of Alaska Fairbanks (UAF) to assess the performance of the mini-RWIS stations with the goal of providing feedback to ADOT&PF regarding the performance of the stations and the feasibility of adding the mini-RWIS station concept as a cost-effective option for filling gaps in the Alaskan RWIS network.

Contract # 2520H016 was entered into with ADOT&PF Design and Engineering Services (DES) for demonstration of the installation, testing and overall effectiveness assessment of the mini-RWIS (scalable RWIS) Pilot Project at eight sites specified by the Alaska DOT&PF.

Alaska DOT&PF manages approximately 70 RWIS stations and/or cameras along Alaska's connected highway system. Due to lack of power infrastructure and/or lack of cellular communication, there are large gaps where no equipment or cameras can be installed due to the current RWIS system requirements. This challenges the maintenance operations decision making as well as limiting public notifications regarding roadway conditions. Adding additional full RWIS sites is not only costly but requires a stable power source and working communications currently not available. This pilot project successfully accomplished a demonstration of small, lower cost "mini-RWIS" stations using low-power cameras and sensors, solar panels, battery power, and cellular communication technology.

The mini-RWIS stations are installed on posts instead of full-sized, tilt-down towers which avoids the need for a concrete foundation and traffic cabinet. They are powered using a solar panel and batteries of sufficient size and number to last the entire winter.

This project was designed to determine the following:

1. Can these stations be used to supplement traditional RWIS stations or to replace traditional RWIS stations in some applications as a cost-effective solution?
 - a. Answer: Yes
2. What are the most common data points used by road weather maintenance staff to make decisions from these systems?
 - a. Answer: Camera imagery, road surface temperature, air temperature, wind speed and direction.
3. Can these systems, using solar panels and batteries,
 - a. Provide data effectively through an Alaska winter?
 - i. Answer: Yes.
 - b. Does cell service work reliably for system use?
 - i. Answer: Yes, in areas with available cellular coverage.
 - c. Do the batteries withstand an appropriate life cycle?
 - i. Answer: Yes.
 - d. Do the solar panels provide a reliable charge for the system to perform throughout the study period?
 - i. Answer: Yes.

- e. What are the maintenance needs of these systems compared to traditional RWIS stations?
 - i. Answer: Minimal maintenance is needed.
- 4. How often are images required to support the data that is being delivered and can the system do that reliably?
 - a. Answer: Images provided hourly were found to be appropriate for confirmation of atmospheric and road surface data being delivered every half hour. Image delivery proved reliable and robust.

Site Selection

Campbell Scientific provided hardware for eight mini-RWIS stations to be installed at four locations in the Central Region, and four in the Northern Region. Sites were selected by ADOT&PF personnel and were guided by the requirement to have reliable cellular coverage and at locations where approval from a Traffic Safety Engineer would not be required. Seven sites were selected based on cellular network availability and being at a location that was either behind a guardrail or in a rest stop pullout to be far enough away from the fog line of the highway to not require Traffic Safety Engineer approval. Seven mini-RWIS stations were installed at the following locations:

- Northern Region:
 - Chena Hot Springs Road @ Roberts Roost Road (behind a guardrail)
 - Alaska Highway @ Mile Post (MP) 1285 (inside the rest stop)
 - Tok Cutoff @ MP 17.5 (east side of Tulsona Creek Bridge, behind a guardrail)
- Central Region:
 - Glenn Highway @ MP 106 (behind a guardrail)
 - Hatcher Pass @ MP 15 (behind a guardrail)
 - Seward Highway @ MP 98.5 (installed on a signpost on a walking/bike path)
 - Seward Highway @ MP 113.5 (installed on road signpost (Telespar), behind guardrail)

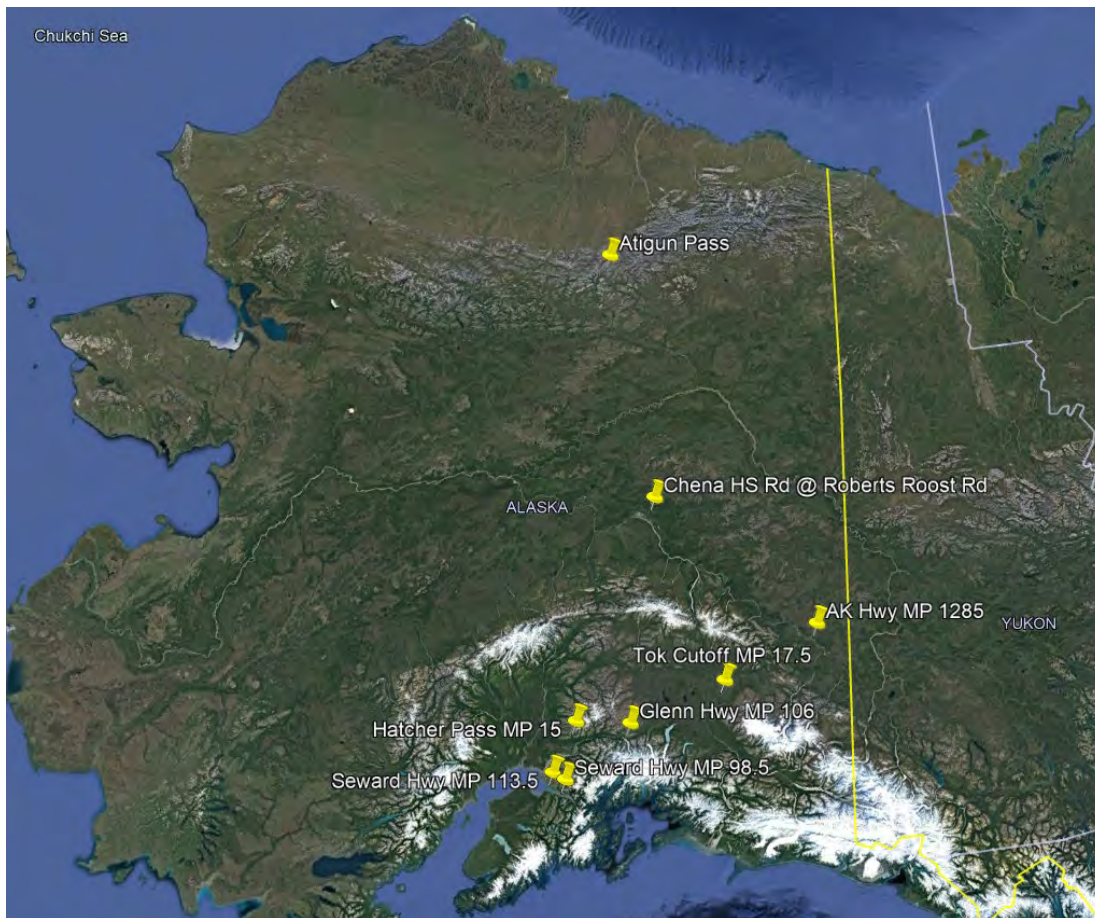

Figure 1: Location of the seven mini-RWIS stations and the Atigun Pass winter-hazards station.

Equipment Used

The major components of equipment used in this mini-RWIS Pilot Project included the items listed below:

Equipment Name	Manufacturer	Description
Mini-RWIS with CR310-Cell205 Datalogger	Campbell Scientific, Inc.	Datalogger with built-in cellular modem
05103-L16	R.M. Young (sold by Campbell Scientific)	Wind Speed and Direction Sensor
SI-4HR-SS	Apogee Instruments	Road Surface Infrared Radiometer Sensor
HygroVUE5-10	Campbell Scientific, Inc.	Air Temperature and Relative Humidity Sensor
CCFC-R2	Campbell Scientific, Inc.	Low Power Field Camera
CH200	Campbell Scientific, Inc.	Smart Regulator and Power Sensor
SP50-L10	Ameresco	50-Watt Solar Panel with 10 ft cable
Pelican Case	Pelican	Durable plastic battery box used at five sites
E64358 Battery Box	Stahlin	Vented battery box used at two sites
Concord Battery	Concord	104 Ahr Battery
Stark Battery	Stark Energy	125 Ahr Battery
Kalifix Breakaway Post System	Kalitec	Mounting Pole used for mounting mini-RWIS sensors, enclosures, solar panels

Additional equipment, including mounting hardware, is not provided in this table, but is provided to ADOT&PF as an Excel file for the purposes of asset management.

UAF Cold Room Testing

A Campbell Scientific mini-RWIS with a CR300 datalogger, provided by Campbell Scientific, Inc for the purpose of testing in the University of Alaska Fairbanks (UAF) cold room was tested by researchers at the Institute of Northern Engineering (INE) Arctic Infrastructure Development Center (AIDC) in the Engineering Learning and Innovation Facility (ELIF) during the summer of 2020. Testing was conducted to verify the operation of the device in extreme cold environments prior to deployment at three roadside sites in Alaska.

Testing in UAF ELIF cold room facility was performed at three different temperature conditions (control 19°C, -20°C, and -40°C) for about one week each using the two supplied 12-volt AGM lead-acid batteries as a power source, monitoring battery performance and power consumption and meteorological data collected by the mini-RWIS. The results showed that the mini-RWIS was able to accurately measure and record temperature data in the three different temperature environments, while consuming very little power (~0.5 watts on average) from the batteries. The system power consumption was highest (~1 watt) while the camera was actuated to take a picture. The power consumption increased significantly in the field when heaters are needed to defog/defrost the camera lens prior to capturing an image. Based on the measurements of battery voltage during all three test conditions, the current battery configuration with two large 12-volt AGM lead-acid batteries in parallel is over-designed for this very low power application. This ensures that it is going to operate through the darkest parts of winter without full solar PV power to maintain full state of charge on the batteries. In

addition, no system faults or equipment failures associated with the mini-RWIS device were encountered during the test period reported here.

Initial UAF analysis of the three sites (Chena Hot Springs Road MP 10, Seward Highway MP 98.5, and Seward Highway MP 113.4) was also performed and included in a report provided by UAF personnel (Richard Weis, Billy Connor, and Elycia Cormier). The full report is included as Appendix A at the end of this report.

System Modifications

Due to the challenges presented to Campbell Scientific (CS) from managing this project remotely during the COVID-19 pandemic CS engaged in discussions with Geo Watersheds Scientific (GWS) to help with the installation and commissioning of mini-RWIS stations. GWS worked together with Campbell Scientific and ADOT&PF personnel to understand the project and then provide suggestions for system design modifications more appropriate for the long, cold Alaskan winter. System modifications included the following:

- Increasing size of power supply (battery bank) to 4x 104 Ahr batteries (for a total of 416 Ahr/station).
- Program modifications to better collect data considering the analysis goals of this project (including processed and tabulated data relevant to atmospheric data, surface temperature data, power data, and cellular communications data)
- Addition of CH200 smart charge regulator for better power management and data collection
 - CH200 can measure and process a variety of power-related information, including temperature, voltage and currents of both system loads and power inputs, as well a smart-charge regulator that can optimize charging to different types of battery systems. The CH200 can output power data to the datalogger through SDI-12 communication standards (requires special cable to datalogger input channels). The newer CH201 provides additional benefits in optimizing solar panel charging and reduces the need for the specialty communication cable.
- Addition of small fiberglass enclosure specifically for the storage of loose, hanging cables. Cable storage in this enclosure reduced the exposed cable to wildlife.
- Mounting hardware modifications for radiation shield (temp/RH) to adapt to Kalitec post.
- Addition of dunnage to system design. Dunnage used to create a solid base for the battery boxes (either Pelican case or metal boxes).
- Adjustment of CCFC camera configuration to reduce energy usage during the Alaskan winter.

Of the seven mini-RWIS stations installed six stations followed the anticipated design using a single pole to mount the enclosure, solar panel, and sensors (sensors include wind speed and direction, temperature/relative humidity, IR temperature sensor for road surface temperature, and CCFC camera). Upon arrival at the Tok Cutoff @ MP 17.5 site Campbell Scientific personnel noted the roadside sign identifying 'Tulsona Creek' (mounted on 1.5" or 2" Telespar square tubing) to have been bent backwards (photo included in Appendix C of this report). It was assumed that the bending of the Telespar tubing was due to snow striking the sign from snow removal operations. As a result, it was decided to modify the station's physical design to be mounted on two poles with the solar panel being located as far from the road as was reasonable. The first pole was used to mount the enclosures, temp/RH sensor, camera and IR temp sensor (road surface temperature) as the camera and road temperature sensor needed to

be located sufficiently close to the road to allow the IR temperature sensor to provide an accurate measurement, while also being far enough away that thrown snow from snow removal operations would not cause the pole to bend or break.

The second pole was used to mount the solar panel and wind speed and direction sensor. The location of this pole required a balance between two hazards:

- 1) the proximity to the roadway and the potential for damage to the solar panel from snow thrown by the snowplow
- 2) the proximity to the spruce trees to the south which would cast unwanted shade on the solar panel during the shortest days of the year, negatively impacting battery recharge.

The decision to pivot to a two-pole system was made by Campbell Scientific personnel while on-site. Fortunately, there was sufficient 'extra' equipment available to be able to accommodate the modified design. The dimensions of the site layout can be found in the site schematics in Appendix B.

Since the Kalitec mounting poles were not bent during the 2021/22 winter season from snowplow-thrown-snow, and because the power system was able to maintain itself during the darkest part of the winter (battery State of Charge on 1/3/22 = 90%) it can be concluded that the location of the two poles achieved the desired goals.

Atigun Pass Project Integration

One of the original station priority locations was at Coldfoot on the Dalton Highway. This was the intended location of the 8th Mini-RWIS demonstration station. Discussions took place about relocating this station to a more challenging location on the Dalton Highway at Atigun Pass. UAF had an existing project "Elucidating snow heights for avalanche assessment through automated data processing from UAS and augmented winter hazards station data." The project objectives include developing unmanned aerial system (UAS) products for avalanching forecasting objectives. The project needed meteorological measurements to support the UAS avalanche forecasting operations.

The decision was made to relocate the 8th Mini-RWIS station to Atigun Pass and alter the station configuration to meet the more demanding needs for avalanche forecasting and the higher, more remote location in the spring and early summer of 2021, and the station was installed in late September, early October 2021. The station equipment utilized some of the original Mini-RWIS station components. Campbell Scientific also provided a series of upgraded equipment for the station to meet the more demanding environment and operational needs and additional equipment was added to the station by the UAS avalanche forecasting project.

The station data collection objectives included air temperature, relative humidity, wind speed, wind direction, barometric pressure, blowing snow fluxes at two heights, snow depth, snow surface temperature, snowpack temperature profiles, camera images at two different zoom magnifications and two different orientations, and station power performance data. Data use objectives included NTCIP compliant data for reporting on the DOT RWIS and 511 public Internet sites, avalanche forecasting applications, support of National Weather Service regional 24/7 forecasting and performance data of the station.

The area does not have any cellular service and a radio communication telemetry network was developed based on Campbell Scientific RF451 radios, which use a Freewave spread-spectrum radio operated in the 900 Mhz range. This radio telemetry solution is utilized throughout Alaska and has proven to be robust in extreme cold weather and operate with very low power requirements. A small repeater site was installed across from the DOT Chandalar Maintenance and Operations (M&O) Camp at the adjacent public airstrip. A base station was located at the Chandalar M&O Camp, which included the equipment to convert the radio communication to IP communications and allow internal DOT access to a Windows server located at the camp, which was running Loggernet Admin. The entire system is within the State of Alaska (SOA) internal firewall and collects data 24/7 and then pushes the data to external GWS servers. Data is then made available for automatic retrieval by the CS Cloud and MesoWest. The MesoWest database systems then allows access by NOAA and NWS data systems and staff.

The station power is based on a single DC battery bank, composed of six (6) Concord SunSaver 1040T batteries (104 Amp-Hr.) for a total capacity of 624 Amp-Hrs. The solar panel is a 90W (CS SP90), which was mounted directly to the mast in a vertical orientation and angled so the predominant winds would help keep snow and ice accumulation on the solar minimized. The solar panel was mounted vertical for both reducing the potential for snow and ice accumulation and to optimize solar charging during the middle of winter, when there is the least amount of daylight hours, and the lowest sun angle on the horizon. A CS CH201 smart charge controller was used to help optimize the charging of the battery bank so that the battery manufacturer recommended charging algorithms can be used on detailed power system data is measured and recorded.

Summary of data

Atmospheric & Road Surface Parameters

UAF personnel provided a report which contains an in-depth analysis of not only the cold room testing, but also the performance of stations throughout the two winter seasons. This UAF report is included as Appendix A of this report.

A high-level overview of the results of the data analysis from the UAF report show that the mini-RWIS stations were able to reliably measure, record, and communicate the air temperature, road surface temperature, humidity, wind speed and direction, and hourly still camera images while consuming on average only about 1.24 watts of power.

The data collected in the cold rooms mimicked the cold room temperatures and relative humidity, although the relative humidity at cold temperatures is essentially 100%. Atmospheric data values measured in the field have been within the range anticipated. Unfortunately, we have no absolute comparisons other than those obtained in the cold rooms. A comparison of the two closest RWIS sites (Seward Highway MP 98.5 and Seward Highway MP 113.5) did show similar air temperatures and relative humidity, noting that one site is on the water side of the road while the other is on the cliff side of the road with different exposure to the prevailing winds and weather. Figures 2 and 3 below present a comparison of both Air Temperature and Relative Humidity between these two nearby sites and is based on the analysis presented in the report from the UAF analysis.

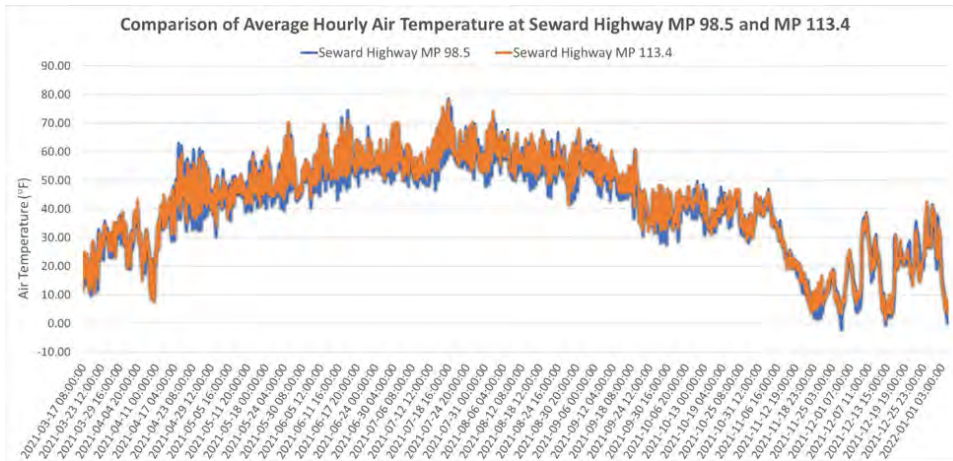

Figure 2: Plot of hourly average air temperature (°F) for Seward Highway MP 89.5 (blue) and MP 113.4 (orange) RWIS sites from March 17, 2021, at 08:00 to January 3, 2022 at 06:00.

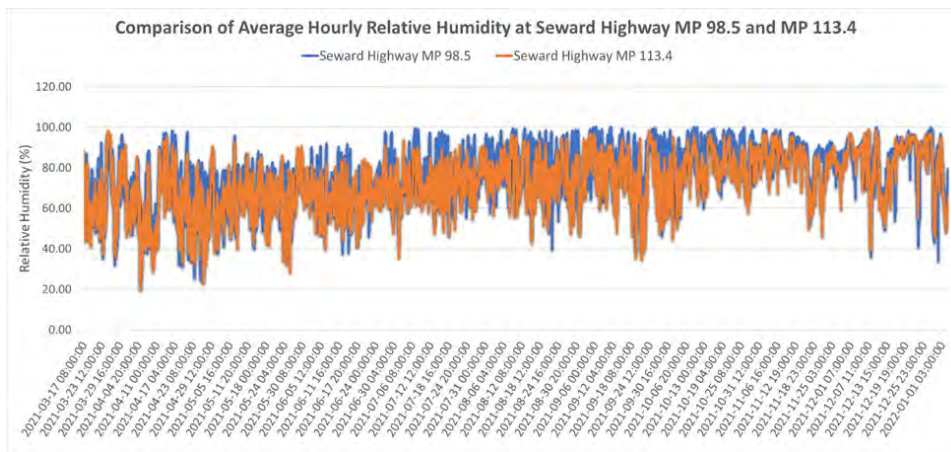

Figure 3: Plot of hourly average relative humidity (%) for Seward Highway MP 89.5 (blue) and MP 113.4 (orange) RWIS sites from March 17, 2021 at 08:00 to January 3, 2022 at 06:00.

Images

Camera images proved to be useful to both ADOT&PF maintenance staff and the general public. ADOT&PF commented during project update meetings that they utilize not only the atmospheric (and road surface temperature) data, but also the images to help make maintenance decisions. ADOT&PF staff also mentioned during project update meetings that comments had been received from the public on the orientation of the camera at the Glenn Highway MP 106 site as it was not initially taking images of the roadway but rather the eastern horizon to observe incoming weather. Upon receiving this public feedback, the camera orientation was changed by ADOT&PF personnel toward the roadway and no further public comments/complaints have been received. The fact that ADOT&PF received a complaint on the camera orientation so quickly demonstrates that the public is utilizing the camera images as intended for their own travel-related decision making.

A 'project win' from the use of the low-power CCFC cameras can be seen from the Seward Highway MP 113.5 site where the images were able to provide reliable imagery of the buildup of ice from a water seep on the rock wall near the highway, but more importantly regular images of the ice wall in anticipation of its inevitable collapse onto the highway. The use of camera images to observe the degradation of the ice and its collapse aided ADOT&PF staff as to when to deploy maintenance resources.

The mini-RWIS station at the Hatcher Pass site was able to provide images of the avalanche area allowing M&O staff greater information related to avalanche mitigation decisions. These observations reinforce the need for cameras to be included at RWIS installations. In some cases, the location of the RWIS may be predicated on hazard locations such as rockfalls, avalanche chutes, or ice falls rather than weather observations.

Power

Battery 'State of Charge' (SoC – presented as a percentage) was maintained at or near 100% until early to late November 2021 when the SoC started to drop due to the decrease in daylight hours, resulting in less time for the solar PV module to recharge the batteries. The SoC continued to drop to a low on or around January 3, 2022. The lowest SoC of each station is presented below (which SoC was more than enough to maintain uninterrupted operation of the low-power RWIS):

- Chena Hot Springs Road SoC on 1/3/22; 83%
- Seward Highway MP 113.5 SoC on 1/3/22; 94%
- Seward Highway MP 98.5 SoC on 1/3/22; 95%
- Alaska Highway MP 1285 SoC on 1/3/22; 94.5%
- Tok Cutoff MP 18.5 SoC on 1/3/22; 90%
- Glenn Highway MP 106 SoC on 1/3/22; 88.6%
- Hatcher Pass MP 15 SoC on 1/3/22; 96.5%

As might be expected, the lowest SoC occurred in the highest latitudes i.e., the Chena Hot Springs and in areas where the sun might be occluded due to vegetation or terrain i.e., the Glenn Highway site. It is important that future sites carefully evaluate the latitude and occlusion of sunlight as part of the design of the solar/battery systems.

The systems have proven to be reliable in both cold room and field testing. All seven of the systems deployed in the field have operated without failures. The power system has proven to be extremely robust with an estimated power reserve of nearly double the minimum required. By designing the battery capacity with an adequate buffer, the system can survive unanticipated events such as those which might coat the lens with ice or snow. It also buffers against the decay of battery capacity over time.

The data collected during the 2021 field trials closely mimic the data collected in the cold rooms which provides confidence that the systems will perform as expected. All instrumentation has performed without problems with hoar frost or rime ice. However, there have been occasional issues with moisture on the camera lenses which degrades the image quality for short periods of time.

Cellular Communications and Campbell Cloud

Cellular communications from the mini-RWIS stations proved robust and reliable except for occasional, short periods of down time signal strength fluctuations that self-corrected. Once the issues noted above were resolved, the systems proved to be robust with no downtime observed. Since the communication link between the RWIS and ADOT&PF is critical to the operation of the system, upgrades to the cellular network will need to be monitored to ensure that communications remain stable.

This project implemented the use of cloud-based data transfer through a system that Campbell Scientific developed (and continues to develop) called the Campbell Cloud. The system has been designed to easily interface with the ADOT&PF RWIS website and other systems. As requested by ADOT&PF and UAF the system can validate data and flag data that is not within anticipated values. The development of the cloud base data repository continues to evolve.

At the time of setting up the initial mini-RWIS stations on the Campbell Cloud, Matt Murphy asked if it would be possible to also have one of the ADOT&PF temperature profiling stations stream data through the Campbell Cloud. Sending the temperature profile data to the Campbell Cloud allowed the data to be put through an automated process for numerical as well as graphical presentation that saved significant time for ADOT&PF personnel by not having to manually process data and allowed for rapid decision making. After using the Campbell Cloud to stream temperature profile data it was decided that the interface was of great enough value and saved enough time that all remaining 76 temperature data (TDP) profiling stations would also stream their data through this Cloud-based service.

Installations and Maintenance

Site installations were able to be performed in one day at each of the four sites installed by Campbell Scientific during the September 2021 installations. Those four sites were installed during favorable weather conditions and included AK Hwy MP 1285, Tok Cutoff MP 17.5, Glenn Hwy MP 106, and Hatcher Pass MP 15 sites. The other three mini-RWIS stations were installed in January (2021) during less favorable weather conditions and required snow removal, cold-weather equipment, and special installation equipment to install the Kalitec post base in frozen soil. As a result, these three sites (Chena Hot Springs Rd @ Robert's Roost Rd, Seward Hwy @ MP 113.5, and Seward Hwy @ MP 98.5) it required two+ days to complete each installation. The station at Seward Hwy MP 113.5 was originally planned to be installed using the Kalitec mounting base driven into the ground. GWS attempted to install this station during January 2021 and found the soil conditions far too rocky (as well as frozen) to be able to install the Kalitec post base.

The second station on the Seward Highway (Seward Hwy MP 98.5) was also installed during the winter season and the decision was made by ADOT&PF staff to install this station on the informational sign at a rest area along a walking path parallel to the Seward Highway instead of near the highway itself. Surface temperature measurements are of the walking path surface and are considered to be an analog of the Seward Highway Road surface temperature approximately 90 feet away.

In July of 2022 Campbell Scientific personnel (Kevin Randall and DJ Snodgrass) visited Alaska to perform a maintenance visit at each of the seven mini-RWIS sites and to meet with project stakeholders in both Anchorage and Fairbanks. Annual maintenance at each location was minimal and required no more than approximately one-half hour per site. While on site the following maintenance tasks were performed:

- Lenses on the CCFC camera and IR temperature sensors were cleaned with a clean, dry cloth.

- Wind speed and direction sensor was observed, visually and aurally, for proper functionality and to ensure bearings did not require replacement.
- Air temperature/RH sensor was removed from the radiation shield and the Teflon filter was removed from sensor body and cleaned (just the filter, not the sensor chip) with rubbing alcohol using a Q-tip.
- Cables and cable connections inspected for signs of damage or fatigue.
- Enclosure humidity levels verified by visually observing color-changing humidity indicator card inside enclosure.
- Desiccant bags removed from inside enclosure and replaced with new bags of desiccant.
- Battery health, including voltage (V) and capacity (Ahr), were tested using mobile battery tester.
- Visual inspection of inside of battery boxes to insure no water ingress.
- Site observations of the general area including surrounding vegetation and looking for any evidence of problematic conditions requiring correction.

During the July 2022 maintenance visit no issues were found with any of the atmospheric/road surface temperature sensors (wind speed/direction, IR temperature sensor, temp/RH). All appeared to be operating as expected. Likewise, no concerns were noted regarding the condition or functionality of the cameras, cables, enclosures, mounting hardware, battery boxes or batteries. All stations were found to be upright and undamaged from snow removal activities during the 2021/2022 winter season. Battery health was found to be excellent (average voltage was found to be around 13.3 V). Battery capacity was found to be at or near full capacity for all batteries. The interior of all the battery boxes were dry and no points of water ingress were observed.

During the July 2022 maintenance visits Campbell Scientific personnel observed at the Seward Highway MP 113.5 site (station attached to signpost) that the vegetation is getting tall in the area around the solar panel. CS suggests maintenance personnel remove or trim back vegetation near this solar panel as battery recharge will soon be negatively impacted. One additional observation is from the Hatcher Pass MP 15 site where vegetation also appears to be growing close to the solar panel and the same suggestion applies to this site. Also, at the Hatcher Pass MP 15 site it was observed that the padlock on the Pelican battery case was difficult to adjust the numbers on the combination dial due to a buildup of white mineralization (assumed to be from deicing activities). CS personnel used a flathead screwdriver to remove as much mineralization as possible but were unable to remove all of it. CS recommends that the next site visit include supplies to adequately address this issue.

Summary & Conclusions

Throughout the duration of this project Campbell Scientific, in partnership with ADOT&PF, the University of Alaska Fairbanks, and GW Scientific has demonstrated that the mini-RWIS (or scalable RWIS) concept has great applicability in the state of Alaska where traditional RWIS leaves large gaps of critically needed information and imagery that can be used for ADOT&PF decision making, as well as for public use.

Atmospheric data collected from the mini-RWIS stations was found to be accurate, reliable, and useful for maintenance personnel needs. Camera imagery was also found to be reliable in its delivery and especially useful to not only ADOT&PF staff but the public as well. Camera image quality can be impacted by snow or occasionally frost on the camera lenses, but issues of this nature appeared to self-correct reasonably quickly.

Power system design of the mini-RWIS stations proved to be robust and easily capable of lasting through an Alaskan winter without any downtime due to power supply limitations. Camera heater testing was performed to a limited extent at two stations and did not show excessive stressing of the power supply.

Cellular connections proved to be reliable throughout the study period, although due to gaps in cellular coverage site selection was limited to areas where cellular coverage could be maintained reliably.

Installations, using the Kalitec post system, proved to be possible to complete in one day per station so long as installations were performed during times of the year when cold weather wouldn't prevent additional challenges. Site specific conditions led to physical system design modifications which could be eliminated in the future by having a more in-depth site reconnaissance performed.

Recommendations

Campbell Scientific learned a great deal throughout the duration of this project and would like to provide the following recommendations:

- System design modifications be explored that utilize a different mounting system that does not limit station placement to behind guardrails, inside rest areas, or limited to clear zones.
- Additional communications options be explored, including satellite and radio (if appropriate) so that station placement can be expanded to outside the cellular network coverage areas. Radio telemetry was successfully used at Atigun Pass and in a number of the early main RWIS sites.
- Preinstallation site visits to anticipated station locations should be done to eliminate surprises on installation day.
 - Example: Tok Cutoff MP 17.5 bent Telespar sign forcing a two-pole station design to be implemented on site.
 - Example: multiple sites had soil conditions that were challenging to drive the Kalitec post base. A combination of hand digging, and auguring (gas-powered handheld auger) was used to achieve desired depth of post base installation.
- Metal battery boxes appear to be more robust (at least in the short term – meaning no rust was observed on the painted metal battery boxes after one year in the field) than Pelican cases. Pelican cases, while still a good option for battery protection, if used in the future should be of a neutral color to not attract attention from the public. Specific site conditions should be evaluated in the early design stage.
- Solar power systems were proven to be effective. Identifying regional design data will help optimize future station across the wide range of solar and climate conditions in Alaska and help optimize future stations to reduce network scale costs.
- Camera operations were shown to be reliable. Continued optimization of camera heaters and ability to have easy control of heating operations and other camera functions would benefit DOT in the future. Short training material developed for ADOT would also help lower future maintenance and operation costs, and improve functionality for the stations.
- ADOT&PF M&O personnel should continue to be aware of the mini-RWIS stations and snowplow drivers should adjust their speed so that snowplow-thrown-snow does not damage equipment installed near roadways, or impact measurements and image collection.
- Campbell Scientific continue to work directly with ADOT&PF to produce a list of items that can be used for the state's needs in the RWIS network. The concept of mini-RWIS, while simple in its

marketing presentation, does not accurately represent the scalability of the Campbell Scientific platform to design a station as simple as one sensor or even more complex than the mini-RWIS concept demonstrated through this project. The Atigun Pass project clearly demonstrates the scalability of the system to extreme-climate conditions and more advanced data-collection objectives.

- Annual maintenance should be performed on existing mini-RWIS stations. If lack of experience with maintenance of data acquisition systems is a limiting factor within ADOT&PF personnel, then maintenance could be performed through a contract with an outside company.
- Campbell Scientific and ADOT&PF work together to develop a decision-making plan for when to use certain communications options (i.e., radio, satellite, cellular).
- Campbell Scientific and ADOT&PF work together to develop a list of parameters that could be used on the 'scalable' (mini) RWIS platform for network densification purposes and future upgrades for existing stations.

Acknowledgements

Campbell Scientific would like to acknowledge the positive working relationship developed with ADOT&PF and UAF staff and looks forward to future collaboration on RWIS projects both large and small. Campbell Scientific would also like to acknowledge the tremendous time and effort provided by Michael Lilly and GWS personnel to the success of this project. Michael Lilly's experience with system design and installation was invaluable to this project and included the use of the GWS server as a project document repository of information. It is estimated that Michael's time commitment to this project was in the hundreds of hours and his efforts are sincerely appreciated! We would also like to acknowledge Eyal Saiset and the "Elucidating snow heights for avalanche assessment through automated data processing from UAS and augmented winter hazards station data" project team for their work at Atigun Pass on the Dalton Highway and the advanced integration of the station contributed from this project.

Appendix A: UAF Report

EXECUTIVE SUMMARY

The Alaska Department of Transportation and Public Facilities (AKDOT&PF) plans for the deployment and testing of low-power roadway weather information systems (RWIS) powered by batteries and solar PV and/or wind at various remote roadway sites in Alaska. A Campbell Scientific RWIS with a datalogger, provided by Campbell Scientific, Inc. for this purpose, was initially tested by researchers at the Institute of Northern Engineering (INE) Arctic Infrastructure Development Center (AIDC) in the cold room suite located at the University of Alaska Fairbanks (UAF) in the Engineering Learning and Innovation Facility (ELIF) during the summer of 2020, with the results included in the interim report to AKDOT&PF, *ROADWAY WEATHER INFORMATION SYSTEM: Controlled Cold Room Testing and Evaluation for Remote Alaska Applications with Initial Analysis of Three Alaska Site Installations*. Testing was conducted to verify the operation of the device in extreme cold environments prior to deployment at three roadside sites in Alaska (Chena Hot Springs Road MP 10, Seward Highway MP 113.4, and Seward Highway MP 98.5) in early 2021. Low-power RWIS were deployed at four more roadside sites (Alaska Highway MP 1285, Tok Cutoff MP 18.5, Glenn Highway MP 106, and Hatcher Pass MP 15) in September 2021. Analysis of data collected from all seven sites in Alaska in 2021 is included in this report.

Analysis of the environmental data (ambient air temperature, road surface temperature, humidity, etc.) and operational data (average hourly, daily, and monthly power consumption and battery SoC and voltage) collected from the seven site installations during 2021 was performed and reported. The environmental data (ambient air temperature, road surface temperature, humidity, etc.) were all within the ranges expected from each of the sites. The operational data (average hourly, daily, and monthly power consumption and battery state of charge and voltage) were also consistent with values observed during the cold room testing. The average hourly power consumption was about 1.5 watts or lower depending on camera usage, air temperature, and the frequency of communication link activity. The maximum power consumption was around 6-7 watts when the communication link was activated. The battery parameters (state of charge and voltage) indicated that the available battery capacity was more than adequate for the system to operate for extended periods of time without recharging.

Images of the road at some sights were of poor resolution. If this presents a problem for the visual assessment of road surface conditions, the manufacturer may want to consider using a higher resolution camera in the RWIS. Also, in times when the camera lens ices up or fogs over, heaters would need to be installed. These heaters would consume significant power, resulting in more discharge of the batteries. A plan for testing a heated camera was developed and tested with the heater being activated for a short time prior to an image capture. Increasing the frequency of the captures would result in increased power consumption. This could be problematic during winter months when solar PV resources to recharge to batteries are limited.

Overall, the results of the analysis of data from the cold room testing and the eight site installations showed that the low-power RWIS units were able to measure and record accurate meteorological data as evidenced by temperature measurements without any significant reduction in the state of charge of the batteries. Long-term operation of low-power RWIS stations deployed at roadway sites in Alaska is needed for identification of any problems and development of possible solutions and future improvements.

INTRODUCTION AND RESEARCH APPROACH

Problem Statement and Objective

The development of low-power RWIS powered by batteries and solar PV and/or wind has resulted in interest from the AKDOT&PF in deployment of such devices at various roadway sites in Alaska. Consequently, the AKDOT&PF has a need for testing, investigation, and analysis of a low-power RWIS developed by Campbell Scientific for remote roadway applications in extreme cold climates with the unit solely powered by deep-cycle lead-acid batteries and recharged by solar PV. The objective of this study was to first test and evaluate the operation of a Campbell Scientific RWIS with data logger at different temperatures in the UAF cold room suite, with results documented in the interim report to AKDOT&PF, *ROADWAY WEATHER INFORMATION SYSTEM: Controlled Cold Room Testing and Evaluation for Remote Alaska Applications with Initial Analysis of Three Alaska Site Installations*.

An updated version of the low-power RWIS was installed at seven roadside locations in Alaska. RWIS were installed at Chena Hot Springs Road MP 10, Seward Highway MP 98.5, and Seward Highway MP 113.4 in early 2021, and at Alaska Highway MP 1285, Tok Cutoff MP 18.5, Glenn Highway MP 106, and Hatcher Pass MP 15 in September 2021. Analysis of data collected from seven installations of these low-power RWIS in Alaska was performed and the results included in this report.

Scope of Study and Approach

This study analyzed the results of testing a low-power RWIS device from Campbell Scientific with a data logger under three different temperature conditions in the cold room suite located at the University of Alaska Fairbanks in the Engineering Learning and Innovation Facility. Testing was performed at three different temperature conditions (control room @ 19°C, -20°C, and -40°C) for about one week each using the two supplied 12-volt lead-acid batteries as a power source, while separately monitoring and recording battery performance and power consumption data in addition to meteorological data collected by the RWIS. The following data was used to evaluate the performance of the system.

- 1) Ambient air temperature.
- 2) Battery voltage for determining state of charge (SoC).
- 3) Power supplied to the RWIS and all the meteorological sensors.

The outcomes from this study were: (1) testing and confirmation of operation of a standalone low-power RWIS and the associated meteorological sensors in extreme cold environments, and (2) recommendations to the AKDOT&PF for deployment and operation of standalone low-power RWIS in extreme cold environments as documented in the interim report.

This study also provided an analysis of environmental data (ambient air temperature, road surface temperature, humidity, etc.) and operational data (average hourly, daily, and monthly power consumption and battery SoC and voltage) from seven actual roadside sites where the low-power RWIS systems were installed in 2021. Analysis included investigating temperature trends in the data and comparison to historical meteorological data for the site, as well as power consumption and battery SoC at various ambient temperature conditions.

SETUP AND PROCEDURE

Cold Room Testing

The Campbell Scientific RWIS system with CR-300 data logger and associated meteorological sensors was assembled per instructions from Campbell Scientific on a mobile laboratory table in the control room area of the cold room suite at room temperature as illustrated in Figure 1.

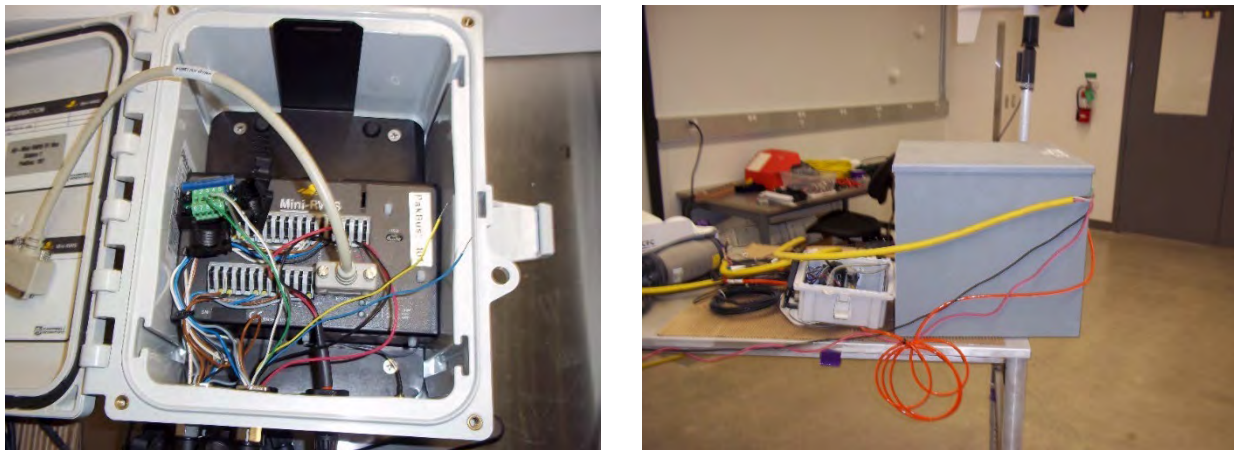

Figure 1: Setup of RWIS for cold room testing. Left: RWIS module showing interior wiring and connections. Right: Mobile laboratory bench set up with RWIS module, battery box, and anemometer.

The details of the setup and procedure for the cold room testing are included in the interim report to AKDOT&PF, *ROADWAY WEATHER INFORMATION SYSTEM: Controlled Cold Room Testing and Evaluation for Remote Alaska Applications with Initial Analysis of Three Alaska Site Installations* and are not repeated here for brevity.

Site Installations

The Campbell Scientific RWIS system with CR-300 data logger, associated meteorological sensors, two deep cycle lead-acid batteries, and solar PV panel were installed by AKDOT, Campbell Scientific, and GW Scientific personnel at seven different Alaska roadside sites. After commissioning of each site, meteorological, battery performance, communication, and power data were collected by Campbell Scientific. The roadside location, data logger number, and installation/commission date for each RWIS are shown in Table 1 below in the order of installation/commission date.

Table 1 RWIS Roadside Location, Data Logger Number, and Installation/Commission Date

Logger Number	Roadside Location	Installation/Commission Date
302	Chena Hot Springs MP 10	1/28/2021
301	Seward Highway MP 113.4	3/9/2021
304	Seward Highway MP 98.5	3/18/2021
202	Alaska Highway MP 1285	9/15/2021
101	Tok Cutoff MP 18.5	9/18/2021
201	Glenn Highway MP 106	9/21/2021
303	Hatcher Pass MP 15	9/26/2021

Logger Number	Roadside Location	Installation/Commission Date
302	Chena Hot Springs MP 10	1/28/2021
301	Seward Highway MP 113.4	3/9/2021
304	Seward Highway MP 98.5	3/18/2021
202	Alaska Highway MP 1285	9/15/2021

RESULTS AND DATA ANALYSIS

Cold Room Testing Analysis

The meteorological, battery performance, and power data collected and stored on the desktop PC were used to analyze the operation of the RWIS at each air temperature. Analysis of the overall data sets was completed, and any significant observations or irregularities were identified. Air temperature measurements were only recorded at a few points for each temperature setting due to improper setup of the Campbell Scientific RWIS data recorder. Therefore, those temperature measurements are presented in Table 2. The air temperatures above 0°C were recorded in the control room during transitions to and from the cold rooms for battery recharging.

Table 2 Air Temperature Measurements for Cold-Room Test of RWIS

Cold Room Test	RWIS Air Temperature (°C)
Control Room Temperature	5.44, 2.28 (during cold room transition) handheld thermometer: 19 (control room)
-20°C Chamber	-18.48, -18.47
-40°C Chamber	-34.57, -35.56, -36.05, -35.12, -35.62

A plot of three complete representative cycles of power consumption (left y axis) and battery voltage (right y axis) over the entire testing period at control room temperature (19°C) is shown in Figure 2.

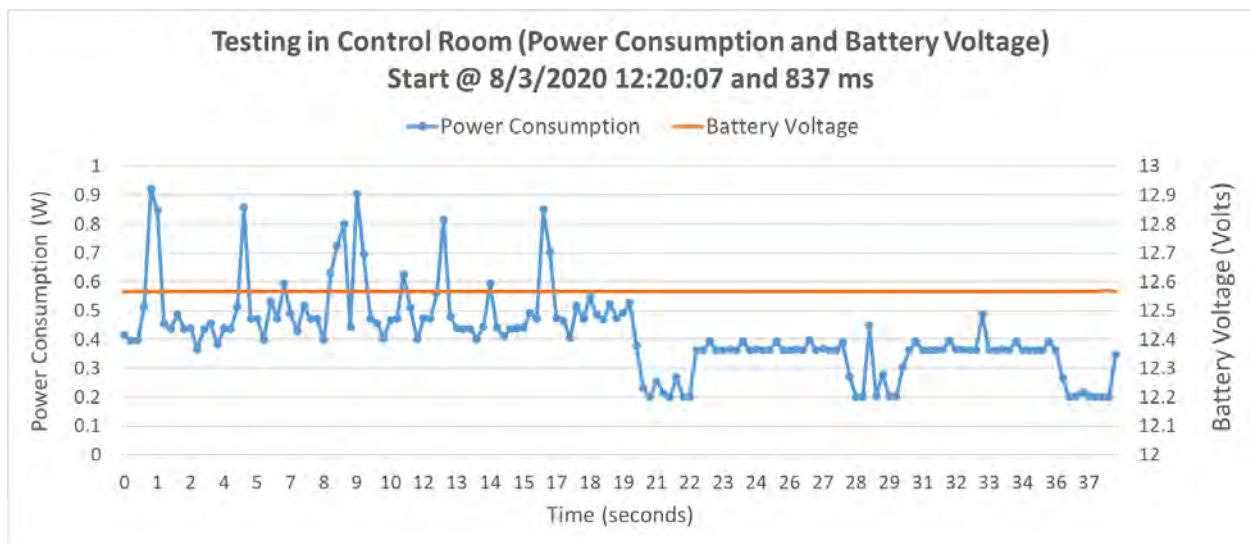

Figure 2: Plot of mini-RWIS power consumption (blue) and battery voltage (orange) for control room temperature test at 19°C for 37.6 second interval showing power cycles.

The results as illustrated in Table 2 and in the plot demonstrate that the mini-RWIS was able to accurately measure the air temperature with low average power consumption (0.42 watts for plotted data) and very little discharge of the batteries over the weeklong test at each temperature. The colder temperature tests resulted in the batteries discharging more, but the system as delivered for testing with the two 12-volt AGM lead-acid batteries in parallel was able to maintain power to the RWIS and associated meteorological sensors without significantly discharging the batteries. This provided evidence to show that the system as tested should be able to operate without solar PV and/or wind to maintain a full SoC on the batteries, if necessary.

In terms of the power profile, the RWIS consumed the most power during communications and camera operation. Peaks in power consumption would be significantly higher by as much as 3 or 4 times when the heater for the camera lens needs to be activated to defog/defrost the camera lens prior to taking an image of the roadway.

Site Data Analysis

Environmental data (ambient air temperature, road surface temperature, humidity, and wind speed) and operational data (average hourly, daily, and monthly power consumption, battery SoC and voltage, and communication link activity) were obtained from seven roadside sites (Chena Hot Springs Road MP 10, Seward Highway MP 113.4, Seward Highway MP 98.5, Alaska Highway MP 1285, Tok Cutoff MP 18.5, Glenn Highway MP 106, and Hatcher Pass MP 15), where the RWIS systems were installed throughout 2021. The air temperature, power consumption, and communication link activity were plotted from the data at each site and used for analysis of their operation for different periods of time ranging from late January 2021 through the end of December 2021 as shown in the following sections. Due to their relative proximity, a comparison of the daily average air temperature, humidity, and wind speed and direction for the two Seward Highway RWIS sites was also performed and is included in a separate section.

Chena Hot Springs MP 10 (Logger 302)

Pictures from the deployment of the RWIS system at Chena Hot Springs Road MP 10 are shown in Figure 3.

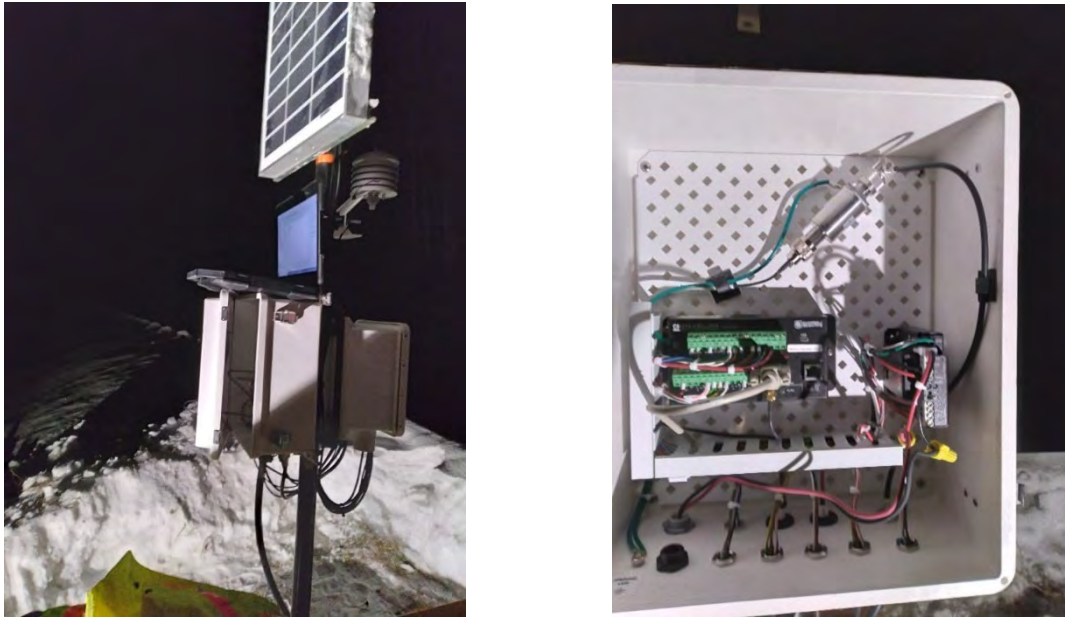

Figure 3: Installation of RWIS system at Chena Hot Springs Road MP 10 on January 21, 2021. Left: pole-mounting with solar module and weather sensors. Right: RWIS data logger mounted on pole.

Environmental data (ambient air temperature, road surface temperature, humidity, and wind speed) and operational data (average hourly, daily, and monthly power consumption and battery SoC and voltage) were obtained from the Chena Hot Springs Road MP 10 RWIS system. The average daily air temperature (Figure 4), daily power consumption with air temperature (Figure 5), and daily average battery SoC (Figure 6) were plotted from late January 28, 2021 to January 3, 2022. The once per minute power consumption (Figure 7) and once per minute communications link activity (Figure 8) were plotted from March 4, 2021 at 23:31 to March 5, 2021 at 01:54 as a representative case.

The results showed that the RWIS station at Chena Hot Springs Road MP 10 was able to measure, record, and communicate the daily average air temperature, road surface temperature, humidity, wind speed and direction, and other relevant meteorological data while consuming on average about 1.36 watts of power. Battery SoC was maintained at or near 100% until late October 2021 when the SoC started to drop likely due to the decrease in daylight hours, resulting in less time for the solar PV module to recharge the batteries (see Figure 6). The SoC continued to drop to around 83% on January 3, 2022, which was more than enough to maintain uninterrupted operation of the low-power RWIS. Peaks of about 6.5 watts were observed at hourly intervals in the once per minute power demand (see Figure 7), which correspond to the communication link activity occurring once every hour (see Figure 8).

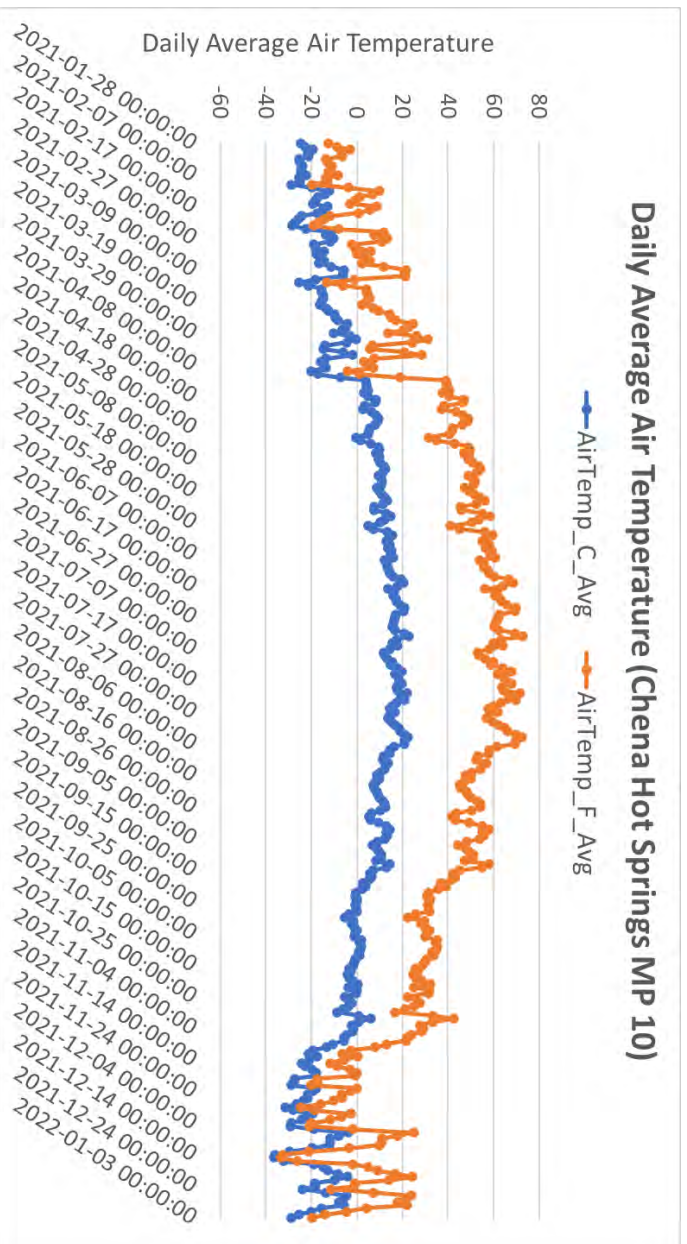

Figure 4: Plot of daily average air temperature profile (°C: blue and °F: orange) for Chena Hot Springs Road MP 10 RWIS site from January 28, 2021 to January 3, 2022.

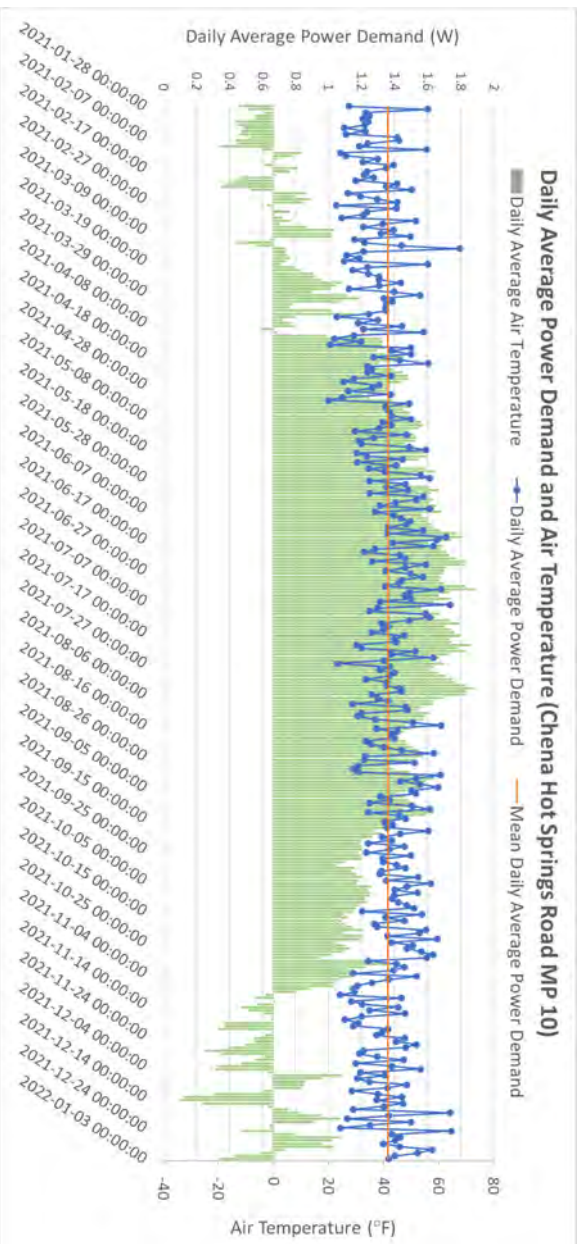

Figure 5: Plot of daily average power consumption (blue), average daily air temperature (green), and annual mean daily power consumption (orange) for Chena Hot Springs Road MP 10 RWIS site from January 28, 2021 to January 3, 2022.

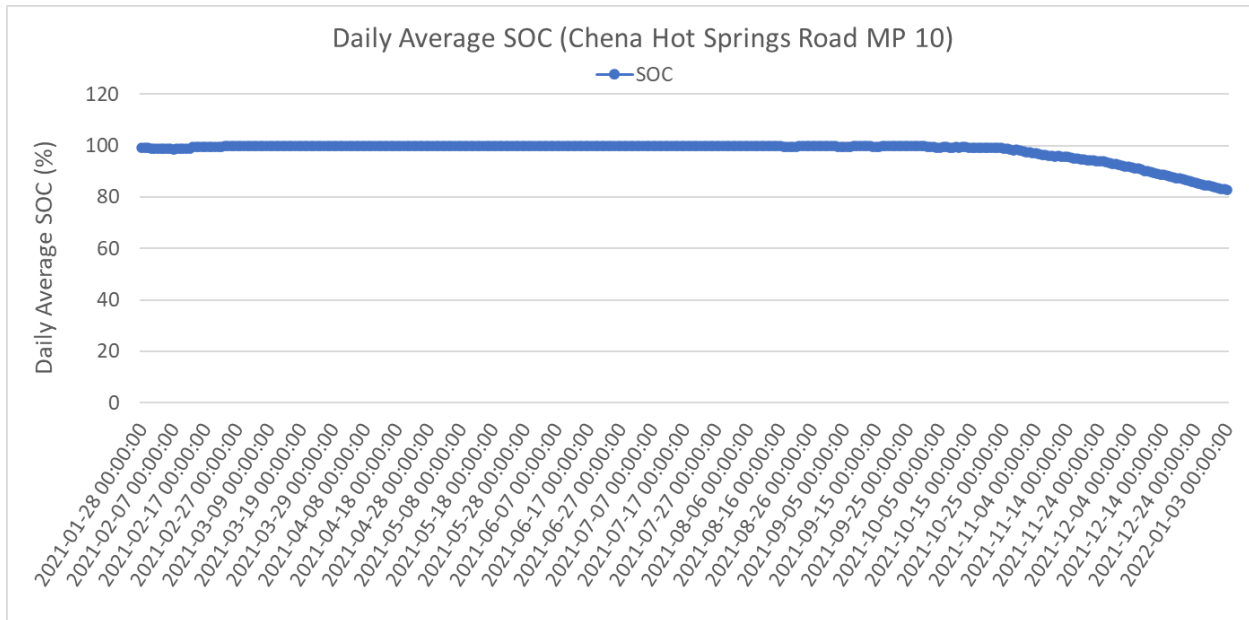

Figure 6: Plot of daily average SOC (blue) for Chena Hot Springs Road MP 10 RWIS site from January 28, 2021 to January 3, 2022.

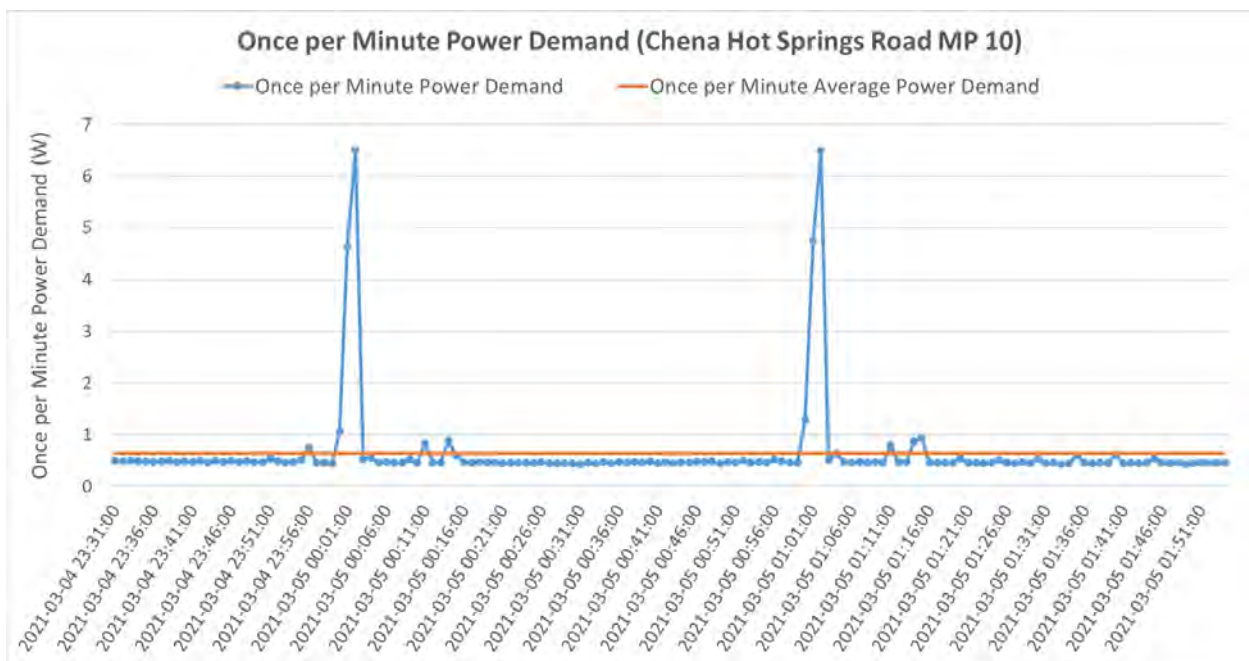

Figure 7: Plot of once per minute power consumption (blue) and mean power consumption (orange) for Chena Hot Springs Road MP 10 RWIS site from March 4, 2021 at 23:31 to March 5, 2021 at 01:54. Peaks of 6.5 W are coincident with hourly data transmission.

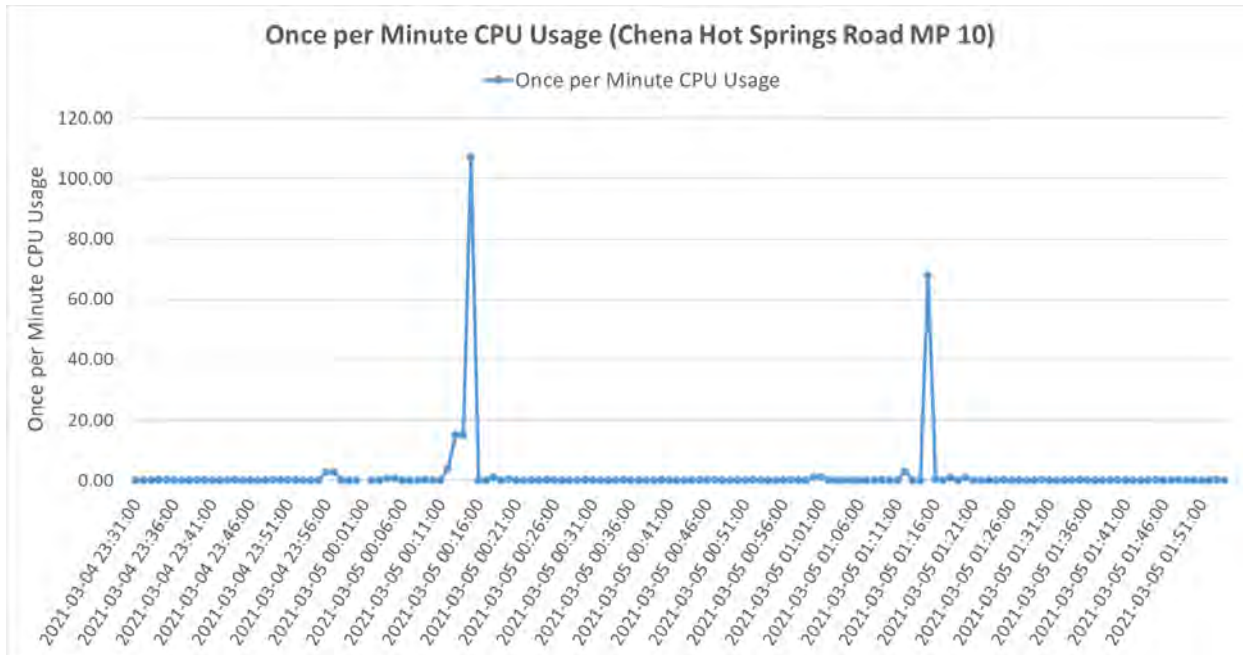

Figure 8: Plot of once per minute CPU usage (blue) for Chena Hot Springs Road MP 10 RWIS site from March 4, 2021 at 23:31 to March 5, 2021 at 01:54. Peaks are coincident with hourly data transmission.

Seward Highway MP 113.4 (Logger 301)

Environmental data (ambient air temperature, road surface temperature, humidity, and wind speed) and operational data (average hourly, daily, and monthly power consumption and battery SoC and voltage) were obtained from the Seward Highway MP 113.4 RWIS system.

The average daily air temperature (Figure 9), daily power consumption with air temperature (Figure 10), and daily average battery SoC (Figure 11) were plotted from March 10, 2021 to January 3, 2022. The once per minute power consumption (Figure 12) and once per minute communications link activity (Figure 13) were plotted over a 24-hour period between from March 8, 2021 at 18:00 to March 9, 2021 at 18:00 as a representative case.

The results showed that the RWIS station at Seward Highway MP 113.4 was able to measure, record, and communicate the daily average air temperature, road surface temperature, humidity, wind speed and direction, and other relevant meteorological data while consuming on average about 1.24 watts of power. Battery SoC was maintained at or near 100% until early November 2021 when the SoC started to drop likely due to the decrease in daylight hours, resulting in less time for the solar PV module to recharge the batteries (see Figure 11). The SoC continued to drop to around 94% on January 3, 2022, which was more than enough to maintain uninterrupted operation of the low-power RWIS. Peaks as high as 7 watts were observed at hourly intervals in the once per minute power demand (see Figure 12), which correspond to the communication link activity occurring once every hour (see Figure 13).

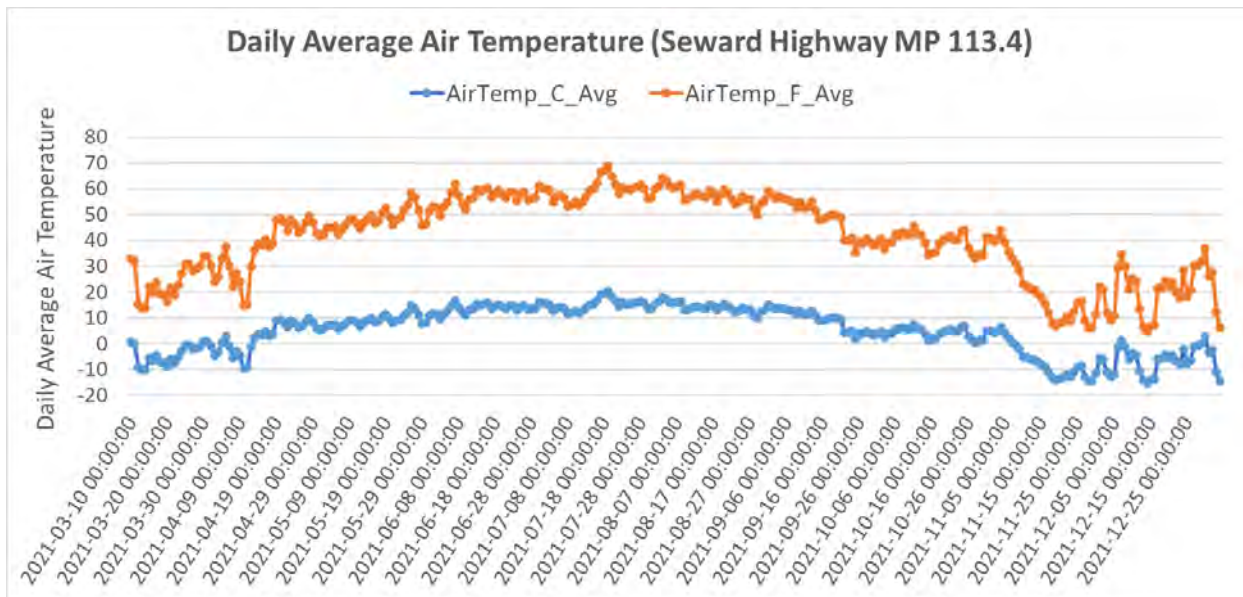

Figure 9: Plot of daily average temperature profile (°C: blue and °F: orange) for Seward Highway MP 113.4 RWIS site from March 10, 2021 to January 3, 2022.

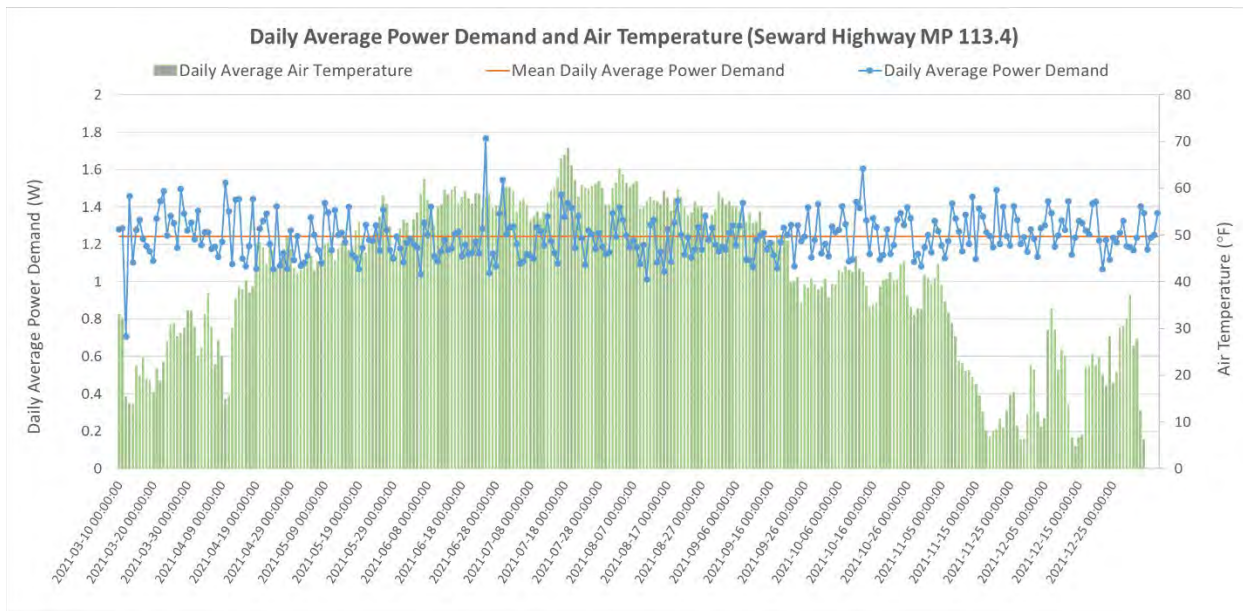

Figure 10: Plot of daily average power consumption (blue), air temperature (green), and mean power consumption (orange) for Seward Highway MP 113.4 RWIS site from March 10, 2021 to May 19, 2021.

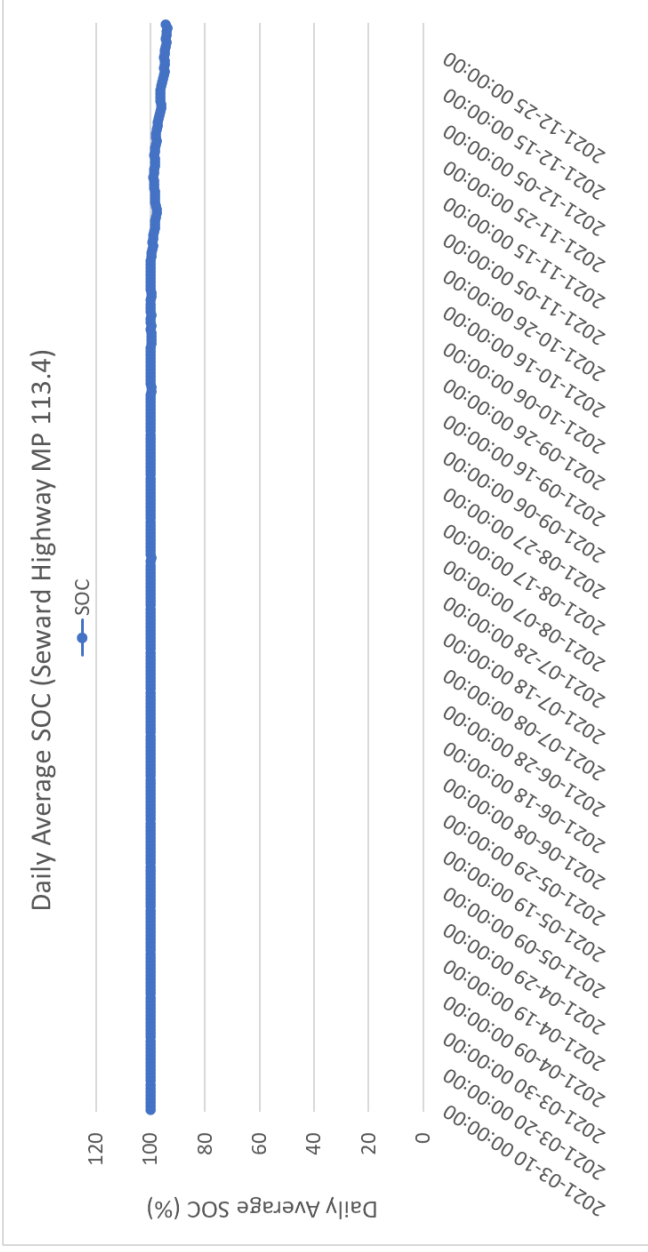

Figure 11: Plot of daily average SOC (blue) for Seward Highway MP 113.4 RWIS site from March 10, 2021 to January 3, 2022.

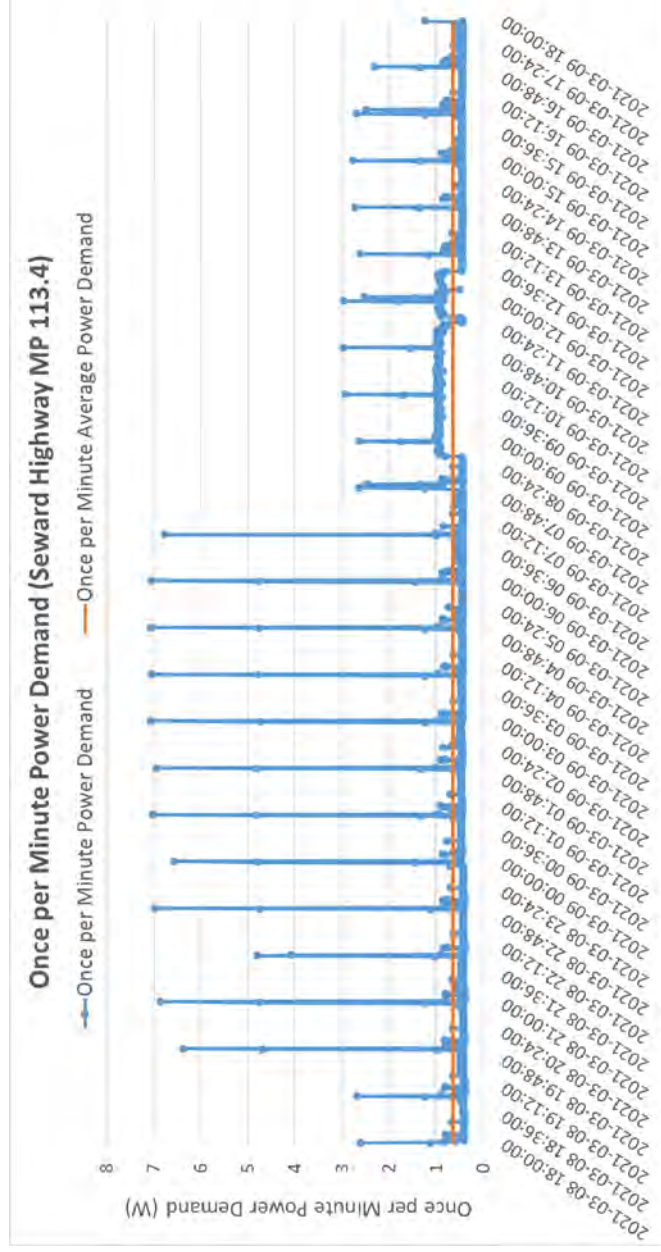

Figure 12: Plot of RWIS once per minute power consumption (blue) and mean power consumption (orange) for Seward Highway MP 113.4 RWIS site from March 8, 2021 at 18:00 to March 9, 2021 at 18:00. Peaks of are coincident with hourly data transmission.

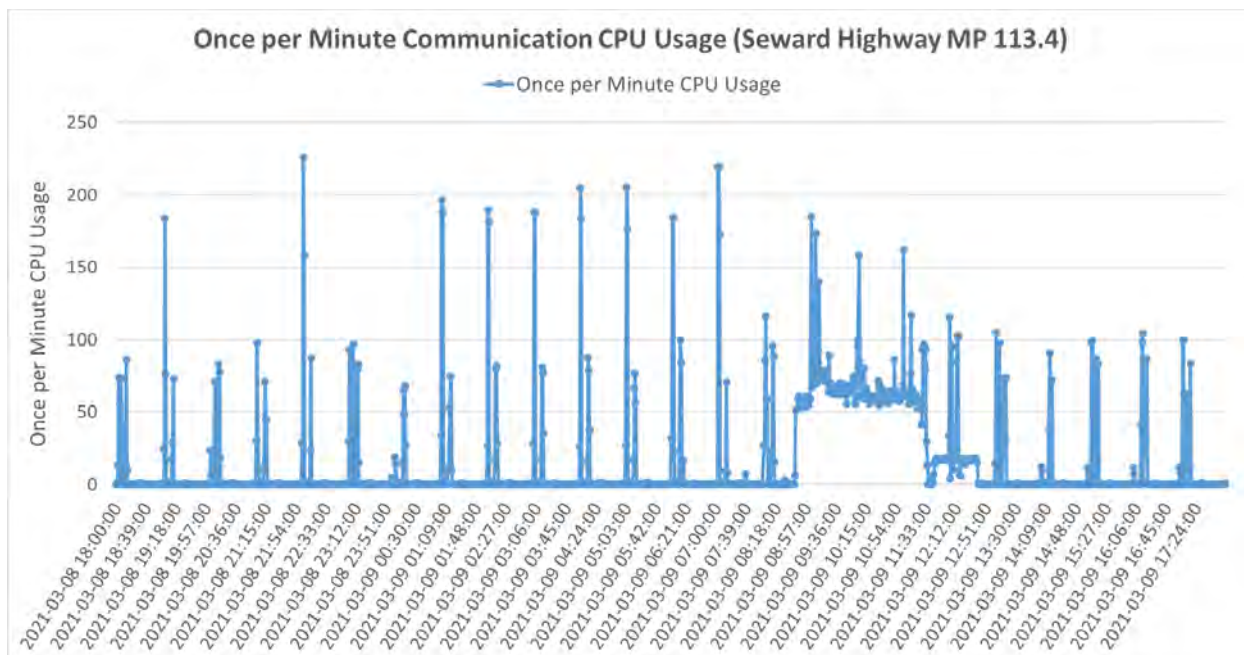

Figure 13: Plot of once per minute CPU usage (blue) for Seward Highway MP 113.4 RWIS site from March 8, 2021 at 18:00 to March 9, 2021 at 18:00. Peaks are coincident with hourly data transmission.

Seward Highway MP 98.5 (Logger 304)

Environmental data (ambient air temperature, road surface temperature, humidity, and wind speed) and operational data (average hourly, daily, and monthly power consumption and battery SoC and voltage) were obtained from the Seward Highway MP 98.5 RWIS system.

The average daily air temperature (Figure 14), daily power consumption with air temperature (Figure 15), and daily average battery SoC (Figure 16) were plotted from March 18, 2021 to January 3, 2022. The once per minute power consumption (Figure 18) and once per minute communications link activity (Figure 19) were plotted over a 24-hour period from March 8, 2021 at 18:00 to March 9, 2021 at 18:00 as a representative case.

The results showed that the RWIS station at Seward Highway MP 98.5 was able to measure, record, and communicate the daily average air temperature, road surface temperature, humidity, wind speed and direction, and other relevant meteorological data while consuming on average about 1.27 watts of power. Battery SoC was maintained at or near 100% until early November 2021 when the SoC started to drop likely due to the decrease in daylight hours, resulting in less time for the solar PV module to recharge the batteries (see Figure 16). The SoC continued to drop to around 95% on January 3, 2022, which was more than enough to maintain uninterrupted operation of the low-power RWIS. Peaks as high as 7 watts were observed at hourly intervals in the once per minute power demand (see Figure 17), which correspond to the communication link activity occurring once every hour (see Figure 18).

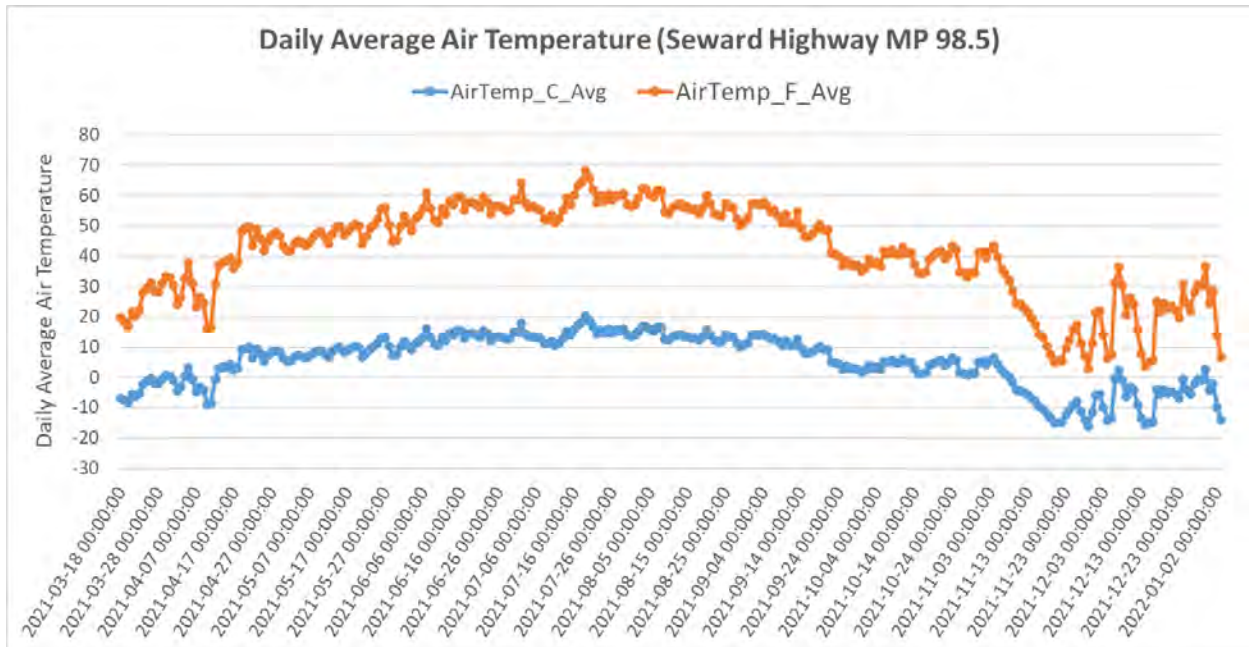

Figure 14: Plot of daily average temperature profile (°C: blue and °F: orange) for Seward Highway MP 98.5 RWIS site from March 18, 2021 to May 19, 2021.

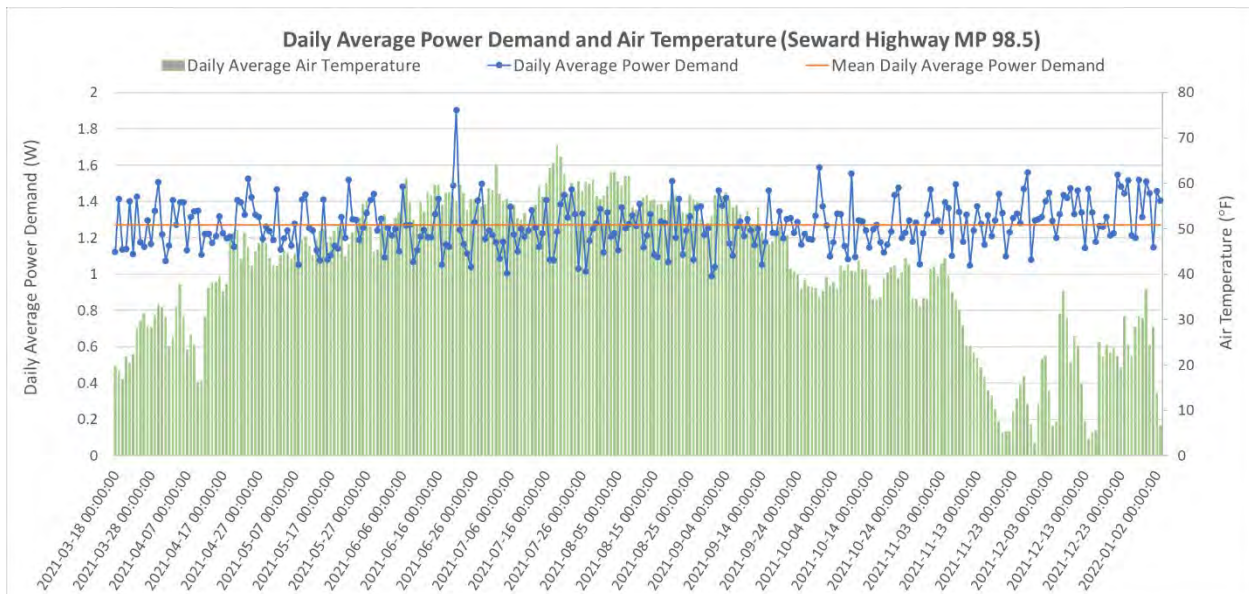

Figure 15: Plot of daily average power consumption (blue), air temperature (green), and mean power consumption (orange) for Seward Highway MP 98.5 RWIS site from March 18, 2021 to January 3, 2022.

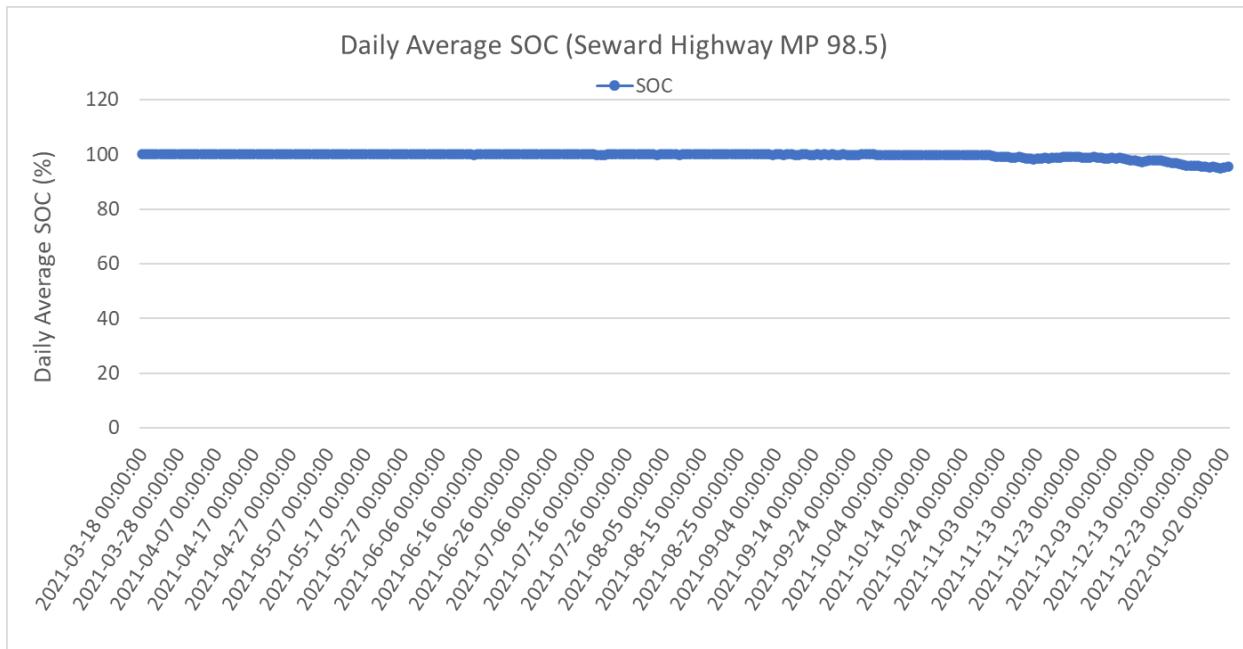

Figure 16: Plot of daily average SOC (blue) for Seward Highway MP 98.5 RWIS site from March 18, 2021 to January 3, 2022.

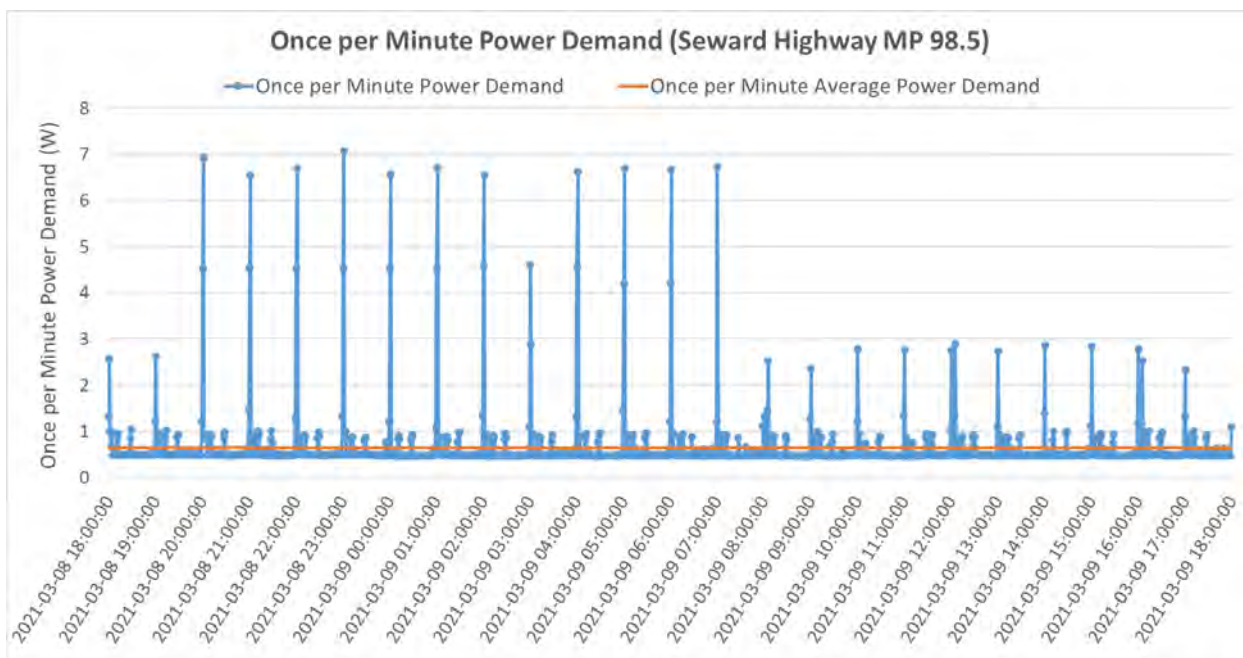

Figure 17: Plot of once per minute power consumption (blue) and mean power consumption (orange) for Seward Highway MP 98.5 RWIS site from March 8, 2021 at 18:00 to March 9, 2021 at 18:00.

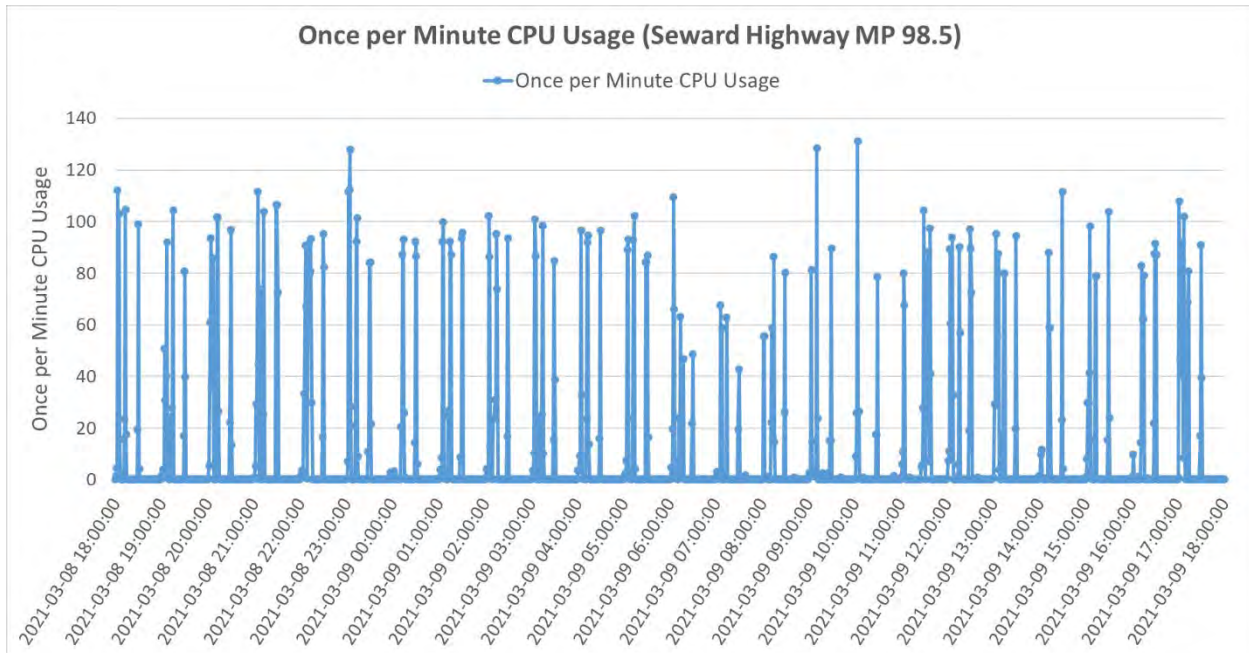

Figure 18: Plot of once per minute CPU usage (blue) for Seward Highway MP 98.5 RWIS site from March 8, 2021 at 18:00 to March 9, 2021 at 18:00.

Comparison: Seward Highway MP 98.5 and MP 113.4 RWIS Meteorological Data

A comparison of the daily average air temperature (Figure 19), relative humidity (Figure 20), wind speed (Figure 21), and wind direction (Figure 22) for the Seward Highway MP 98.5 (blue) and MP 113.4 (orange) RWIS sites was conducted to identify similarities and differences in meteorological measurements given the proximity of the sites.

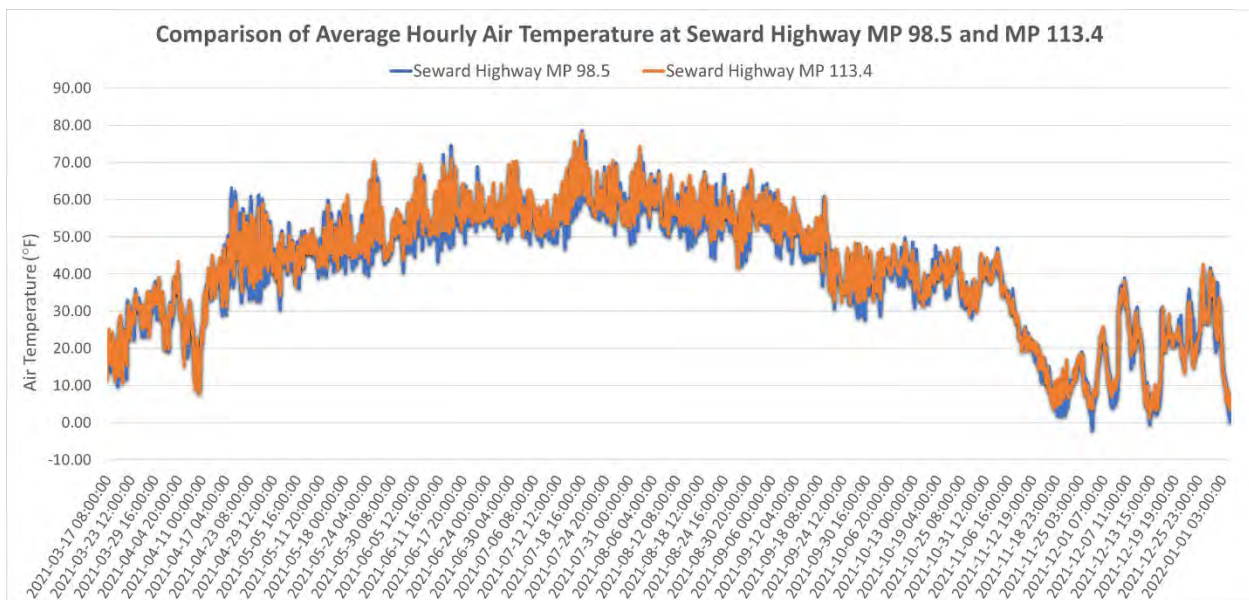

Figure 19: Plot of hourly average air temperature (°F) for Seward Highway MP 89.5 (blue) and MP 113.4 (orange) RWIS sites from March 17, 2021 at 08:00 to January 3, 2022 at 06:00.

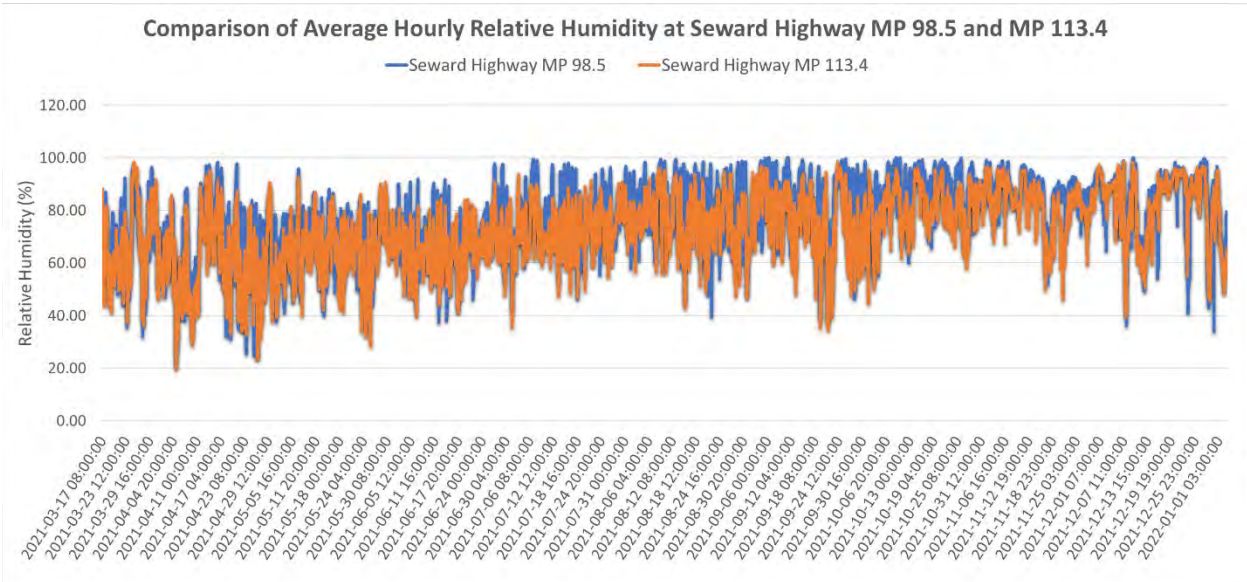

Figure 20: Plot of hourly average relative humidity (%) for Seward Highway MP 89.5 (blue) and MP 113.4 (orange) RWIS sites from March 17, 2021 at 08:00 to January 3, 2022 at 06:00.

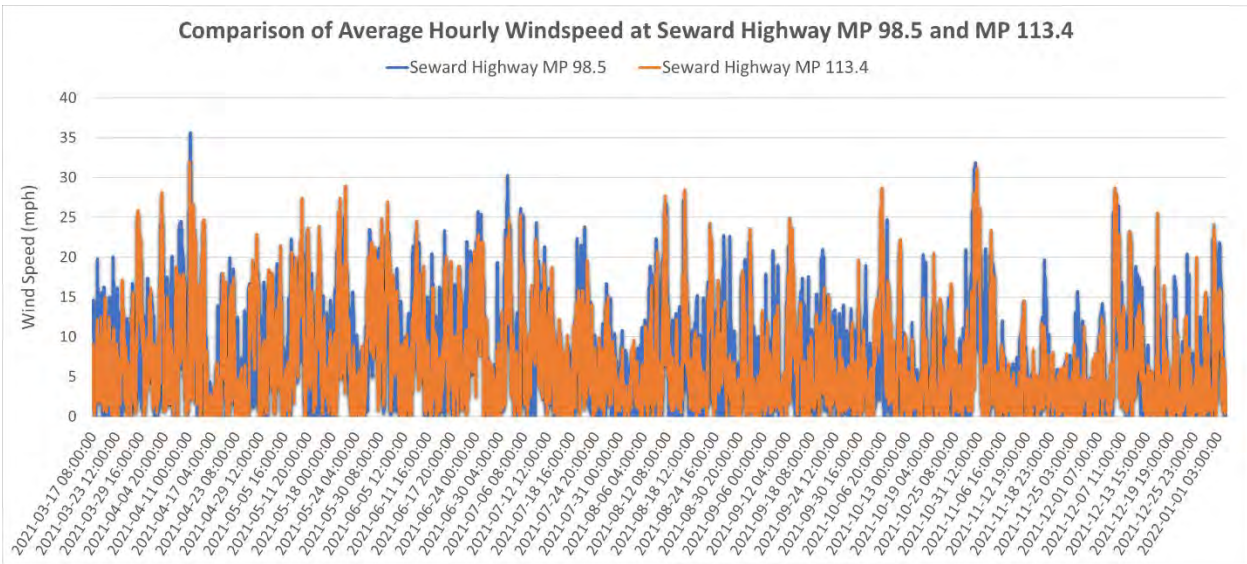

Figure 21: Plot of hourly average wind speed (mph) for Seward Highway MP 89.5 (blue) and MP 113.4 (orange) RWIS sites from March 17, 2021 at 08:00 to January 3, 2022 at 06:00.

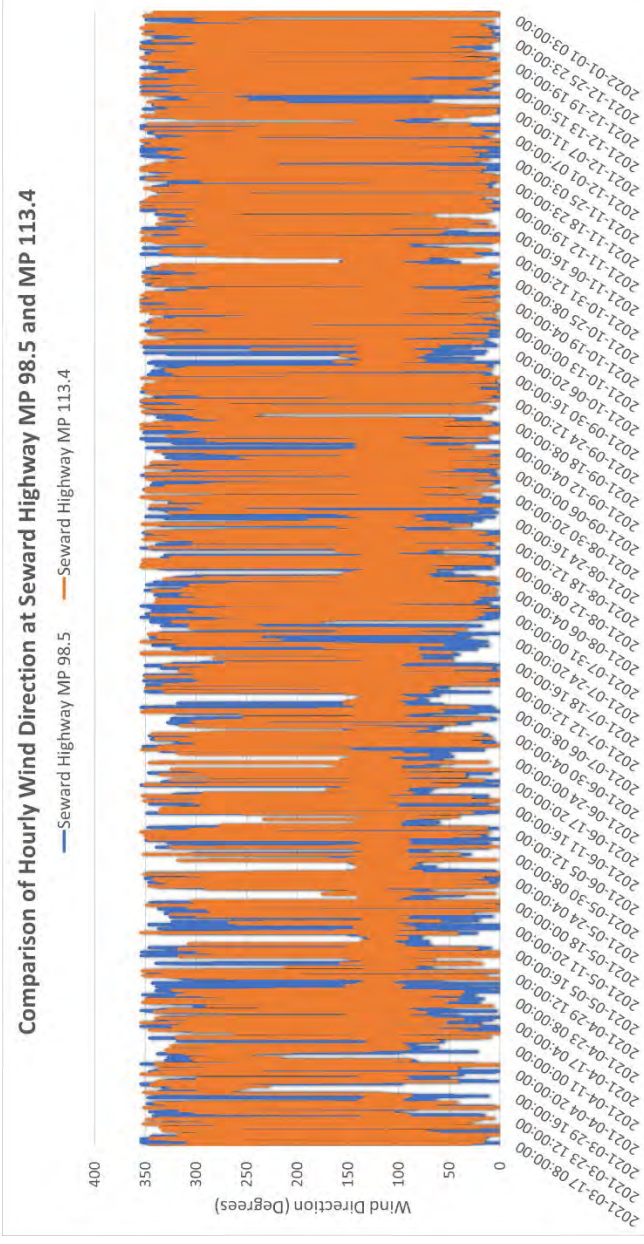

Figure 22: Plot of hourly wind direction (degrees) for Seward Highway MP 89.5 (blue) and MP 113.4 (orange) RWIS sites from March 17, 2021 at 08:00 to January 3, 2022 at 06:00.

The results showed good correlation between the air temperature (Figure 19) and relative humidity (Figure 20) at the two sites, but with slightly higher temperature and humidity swings at the Seward highway MP 98.5 site. More significant differences in wind speed (Figure 21) and wind direction (Figure 22) were also observed. The good correlation in air temperature and relative humidity observed at the two sites indicated that the two systems were at least recording similar temperature and humidity measurements for proximate locations. The slightly higher temperature swings at the MP 98.5 site could be due to differences in solar exposure and location relative to the water side versus the cliff face side of the roadway. The more significant differences in wind speed and direction could also be attributed to differences in exposure due to the landscape at each site.

Alaska Highway MP 1285 (Logger 202)

Environmental data (ambient air temperature, road surface temperature, humidity, and wind speed) and operational data (average hourly, daily, and monthly power consumption and battery SoC and voltage) were obtained from the Alaska Highway MP 1285 RWIS system.

The average daily air temperature (Figure 23), daily power consumption with air temperature (Figure 24), and daily average battery SoC (Figure 25) were plotted from September 15, 2021 to January 3, 2022. The once per minute power consumption (Figure 26) and once per minute communications link activity (Figure 27) were plotted over a 24-hour period from September 14, 2021 at 06:00 to September 15, 2021 at 06:00 as a representative case.

The results showed that the RWIS station at Alaska Highway MP 1285 was able to measure, record, and communicate the daily average air temperature, road surface temperature, humidity, wind speed and direction, and other relevant meteorological data while consuming on average about 1.45 watts of power. Battery SoC was maintained at or near 100% until late November 2021 when the SoC started to

drop likely due to the decrease in daylight hours, resulting in less time for the solar PV module to recharge the batteries (see Figure 25). The SoC continued to drop to around 94.5% on January 3, 2022, which was more than enough to maintain uninterrupted operation of the low-power RWIS. Peaks as high as 7 watts were observed at hourly intervals in the once per minute power demand (see Figure 26), which correspond to the communication link activity occurring once every hour (see Figure 27).

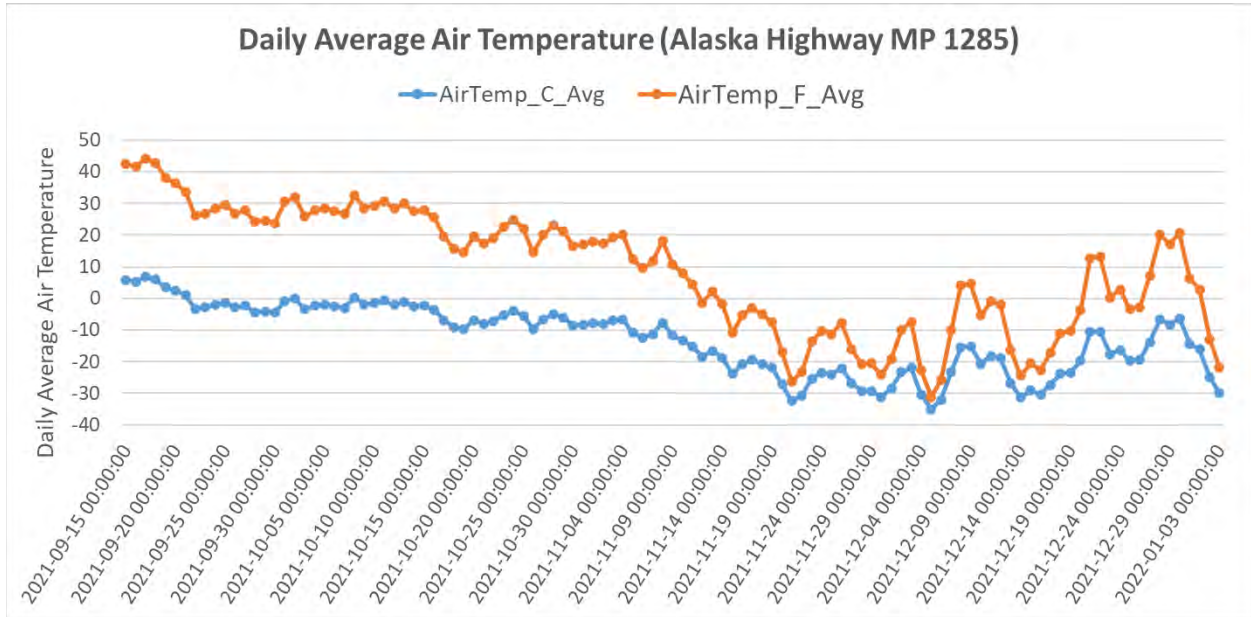

Figure 23: Plot of daily average temperature profile (°C: blue and °F: orange) for Alaska Highway MP 1285 RWIS site from September 15, 2021 to January 3, 2022.

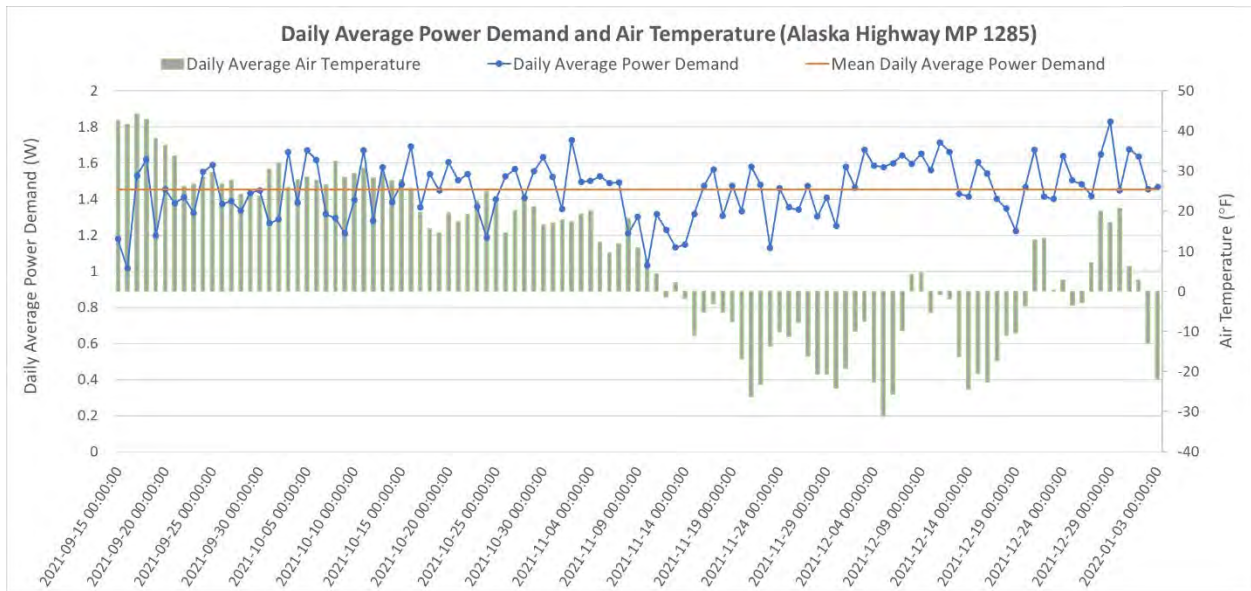

Figure 24: Plot of daily average power consumption (blue), air temperature (green), and mean power consumption (orange) for Seward Highway MP 98.5 RWIS site from September 15, 2021 to January 3, 2022.

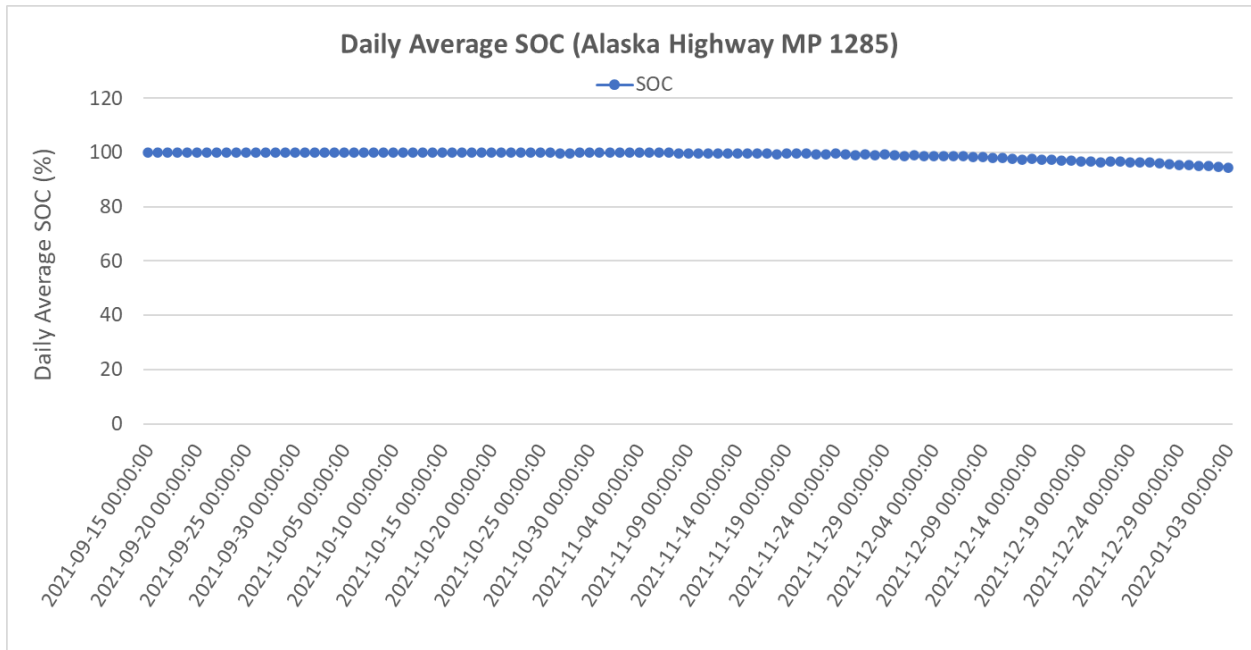

Figure 25: Plot of daily average SOC (blue) for Alaska Highway MP 1285 RWIS site from September 15, 2021 to January 3, 2022.

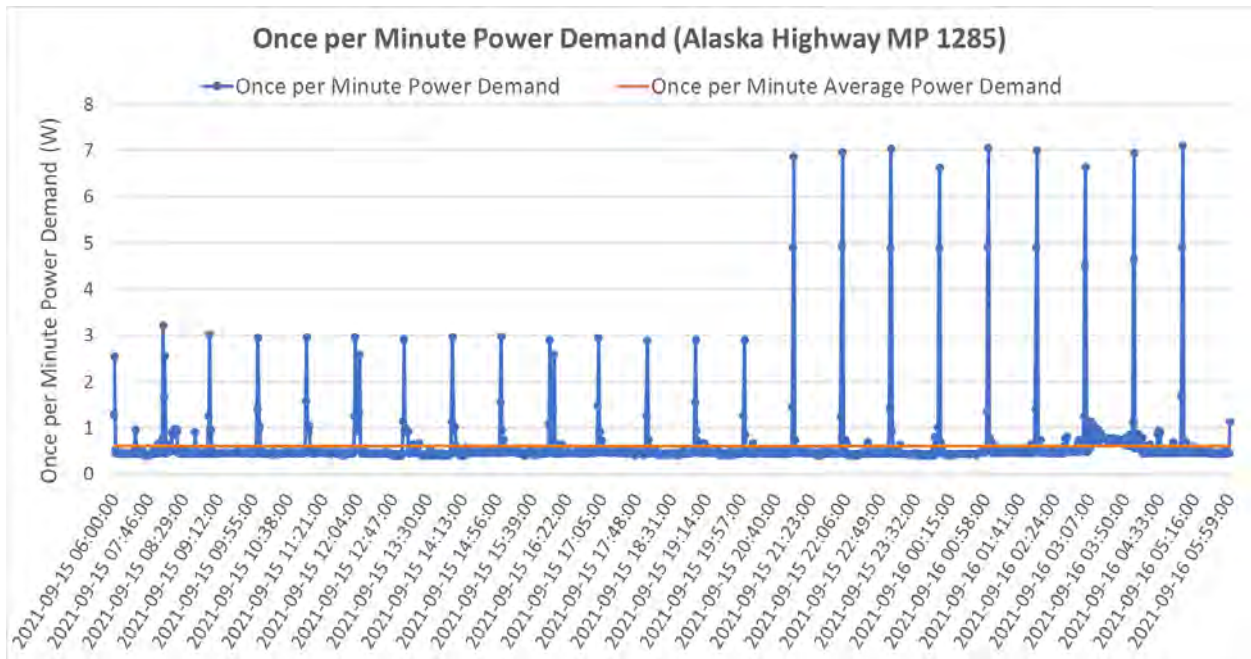

Figure 26: Plot of once per minute power consumption (blue) and mean power consumption (orange) for Alaska Highway MP 1285 RWIS site from September 14, 2021 at 06:00 to September 15, 2021 at 06:00.

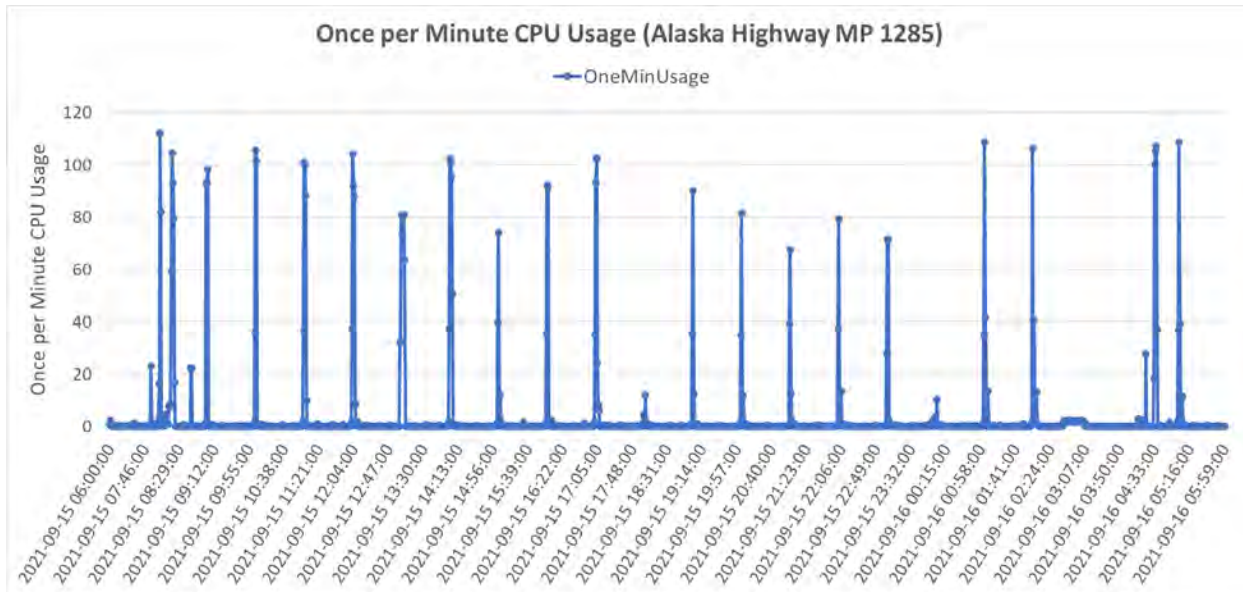

Figure 27: Plot of once per minute CPU usage (blue) for Alaska Highway MP 1285 RWIS site from September 14, 2021 at 06:00 to September 15, 2021 at 06:00.

Tok Cutoff MP 18.5 (Logger 101)

Environmental data (ambient air temperature, road surface temperature, humidity, and wind speed) and operational data (average hourly, daily, and monthly power consumption and battery SoC and voltage) were obtained from the Tok Cutoff MP 18.5 RWIS system.

The average daily air temperature (Figure 28), daily power consumption with air temperature (Figure 29), and daily average battery SoC (Figure 30) were plotted from September 15, 2021 to January 3, 2022. The once per minute power consumption (Figure 31) and once per minute communications link activity (Figure 32) were plotted over a 24-hour period from September 14, 2021 at 18:00 to September 15, 2021 at 18:00 as a representative case.

The results showed that the RWIS station at Tok Cutoff MP 18.5 was able to measure, record, and communicate the daily average air temperature, road surface temperature, humidity, wind speed and direction, and other relevant meteorological data while consuming on average about 1.34 watts of power. Battery SoC was maintained at or near 100% until late November 2021 when the SoC started to drop likely due to the decrease in daylight hours, resulting in less time for the solar PV module to recharge the batteries (see Figure 30). The SoC continued to drop to around 90% on January 3, 2022, which was more than enough to maintain uninterrupted operation of the low-power RWIS. Peaks as high as 7 watts were observed at hourly intervals in the once per minute power demand (see Figure 31), which correspond to the communication link activity occurring once every hour (see Figure 32).

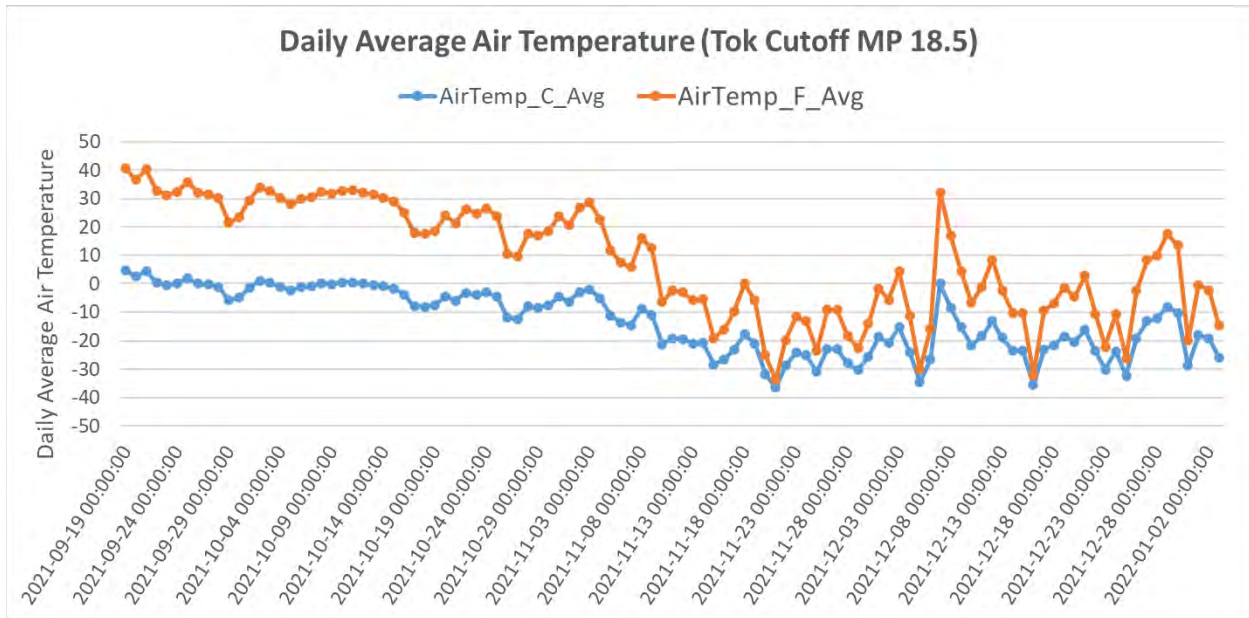

Figure 28: Plot of daily average temperature profile (°C: blue and °F: orange) for Tok Cutoff MP 18.5 RWIS site from September 19, 2021 to January 3, 2022.

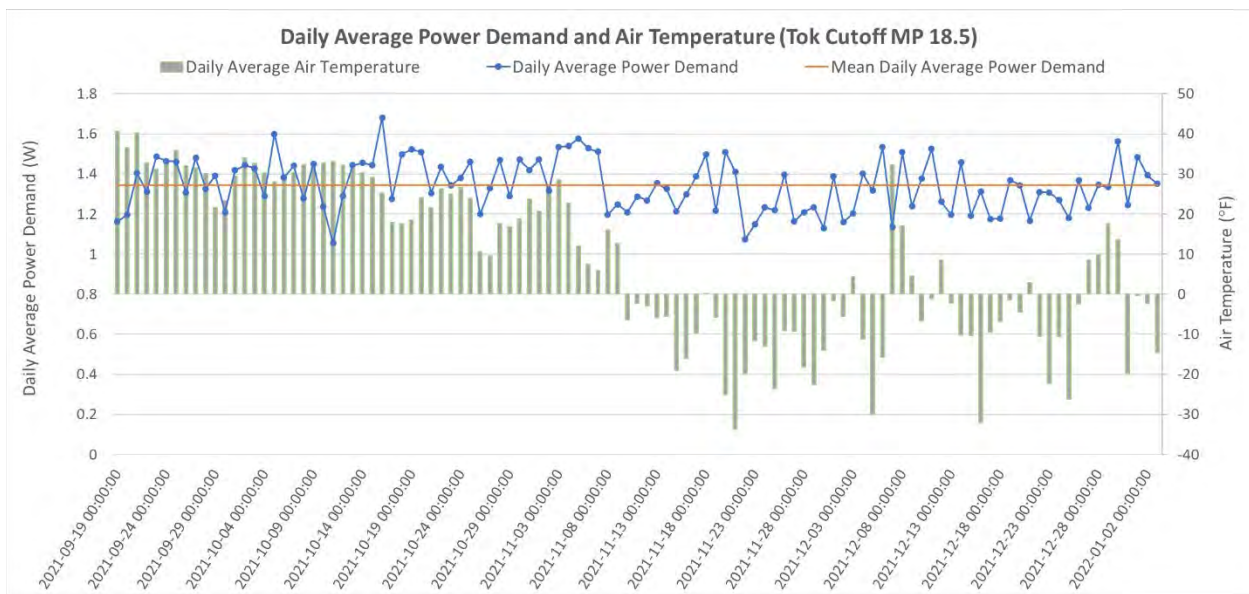

Figure 29: Plot of daily average power consumption (blue), air temperature (green), and mean power consumption (orange) for Tok Cutoff MP 18.5 RWIS site from September 19, 2021 to January 3, 2022.

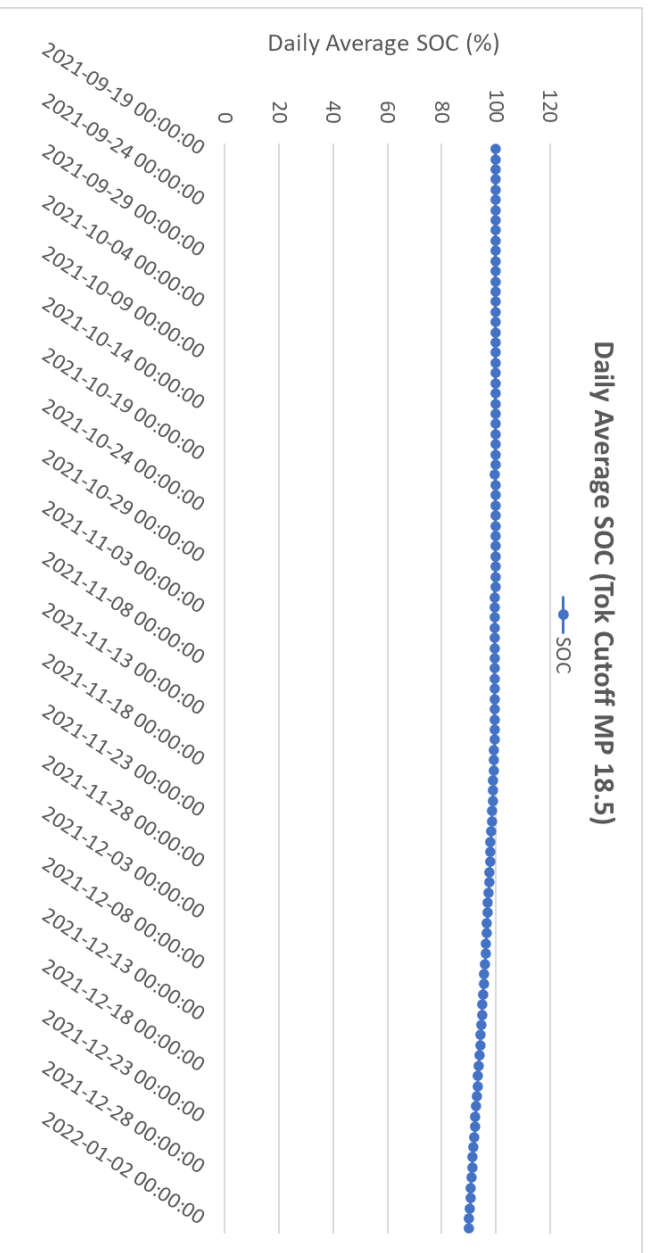

Figure 30: Plot of daily average SOC (blue) for Tok Cutoff MP 18.5 RWIS site from September 19, 2021 to January 3, 2022.

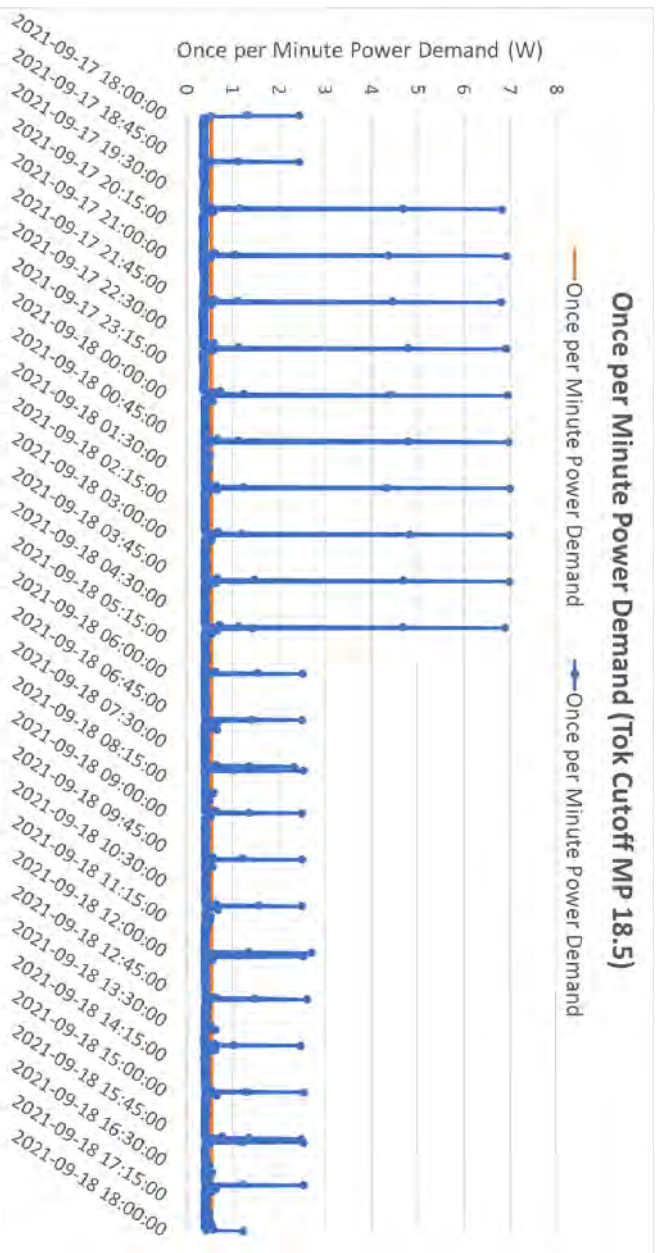

Figure 31: Plot of once per minute power consumption (blue) and mean power consumption (orange) for Tok Cutoff MP 18.5 RWIS site from September 17, 2021 at 18:00 to September 18, 2021 at 18:00.

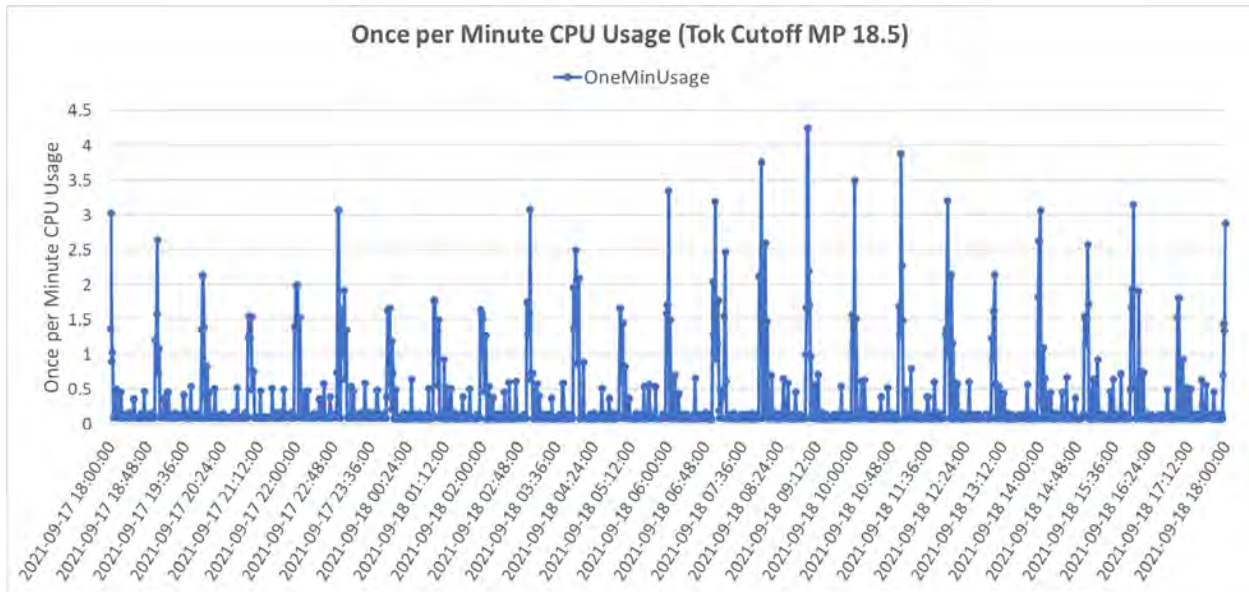

Figure 32: Plot of once per minute CPU usage (blue) for Tok Cutoff MP 18.5 RWIS site from September 17, 2021 at 18:00 to September 18, 2021 at 18:00.

Glenn Highway MP 106 (Logger 201)

Environmental data (ambient air temperature, road surface temperature, humidity, and wind speed) and operational data (average hourly, daily, and monthly power consumption and battery SoC and voltage) were obtained from the Glenn Highway MP 106 RWIS system.

The average daily air temperature (Figure 33), daily power consumption with air temperature (Figure 34), and daily average battery SoC (Figure 35) were plotted from September 22, 2021 to January 3, 2022. The once per minute power consumption (Figure 36) and once per minute communications link activity (Figure 37) were plotted over a 24-hour period from September 21, 2021 at 18:00 to September 22, 2021 at 18:00 as a representative case.

The results showed that the RWIS station at Glenn Highway MP 106 was able to measure, record, and communicate the daily average air temperature, road surface temperature, humidity, wind speed and direction, and other relevant meteorological data while consuming on average about 1.4 watts of power. Battery SoC was maintained at or near 100% until late November 2021 when the SoC started to drop likely due to the decrease in daylight hours, resulting in less time for the solar PV module to recharge the batteries (see Figure 35). The SoC continued to drop to around 88.6% on January 3, 2022, which was more than enough to maintain uninterrupted operation of the low-power RWIS. Peaks as high as 6.5 watts were observed at hourly intervals in the once per minute power demand (see Figure 36), which correspond to the communication link activity occurring once every hour (see Figure 37).

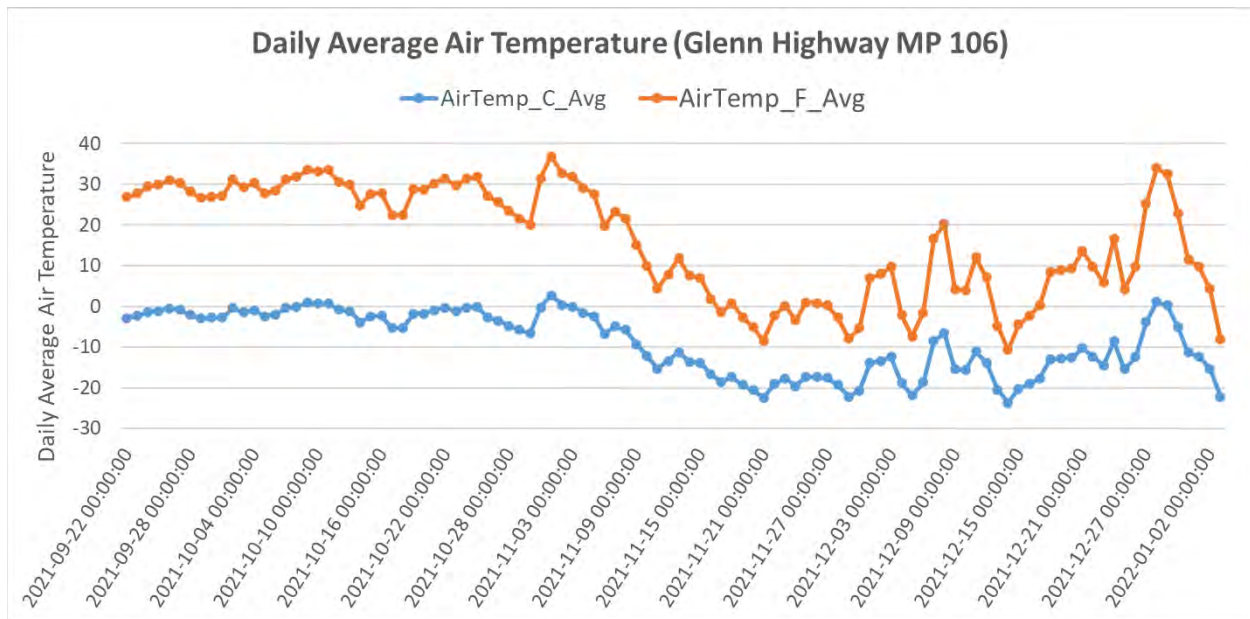

Figure 33: Plot of daily average temperature profile (°C: blue and °F: orange) for Glenn Highway MP 106 RWIS site from September 22, 2021 to January 3, 2022.

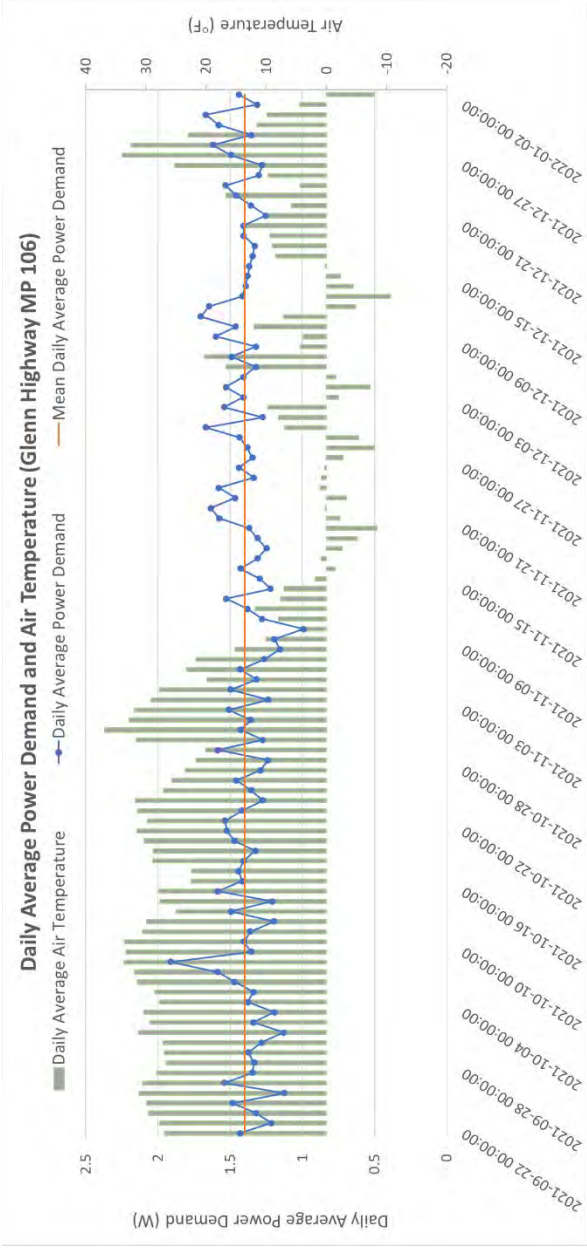

Figure 34: Plot of daily average power consumption (blue), air temperature (green), and mean power consumption (orange) for Glenn Highway MP 106 RWIS site from September 22, 2021 to January 3, 2022.

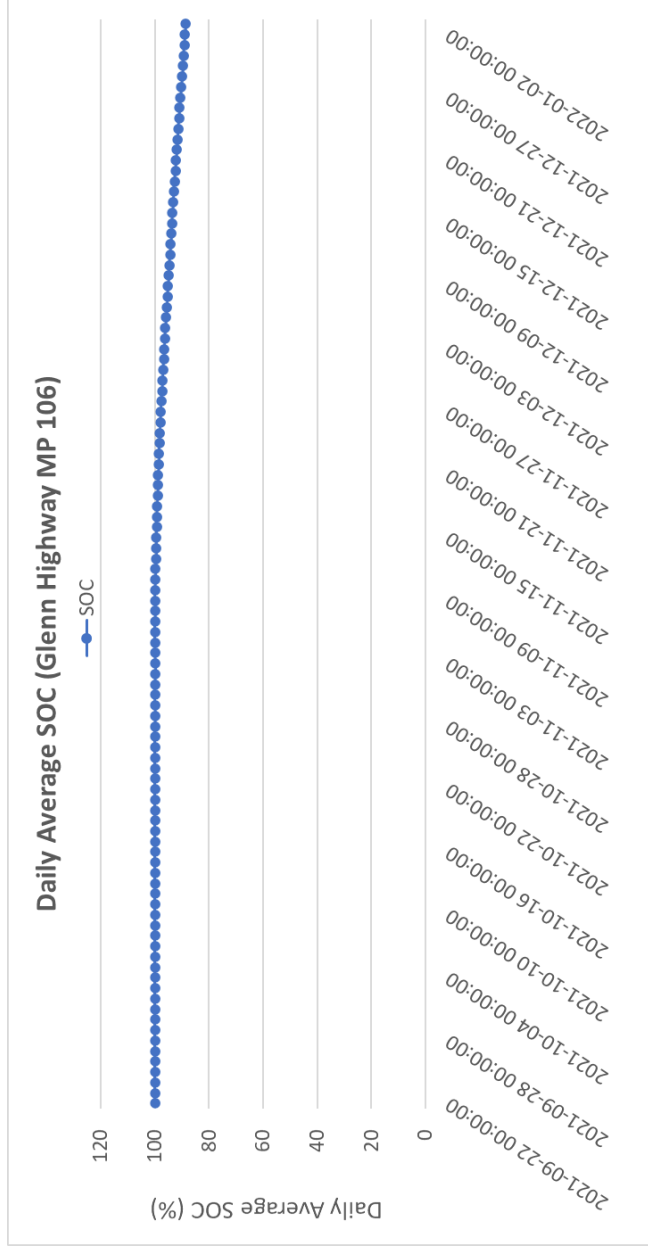

Figure 35: Plot of daily average SOC (blue) for Glenn Highway MP 106 RWIS site from September 22, 2021 to January 3, 2022.

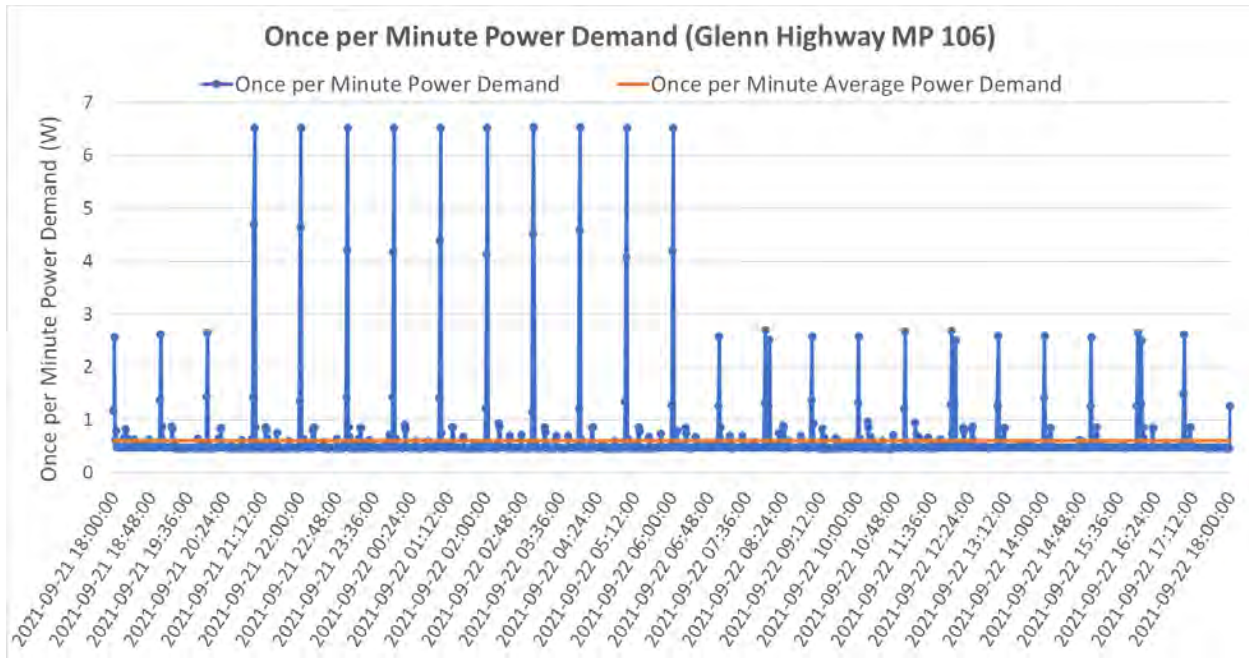

Figure 36: Plot of once per minute power consumption (blue) and mean power consumption (orange) for Glenn Highway MP 106 RWIS site from September 21, 2021 at 18:00 to September 22, 2021 at 18:00.

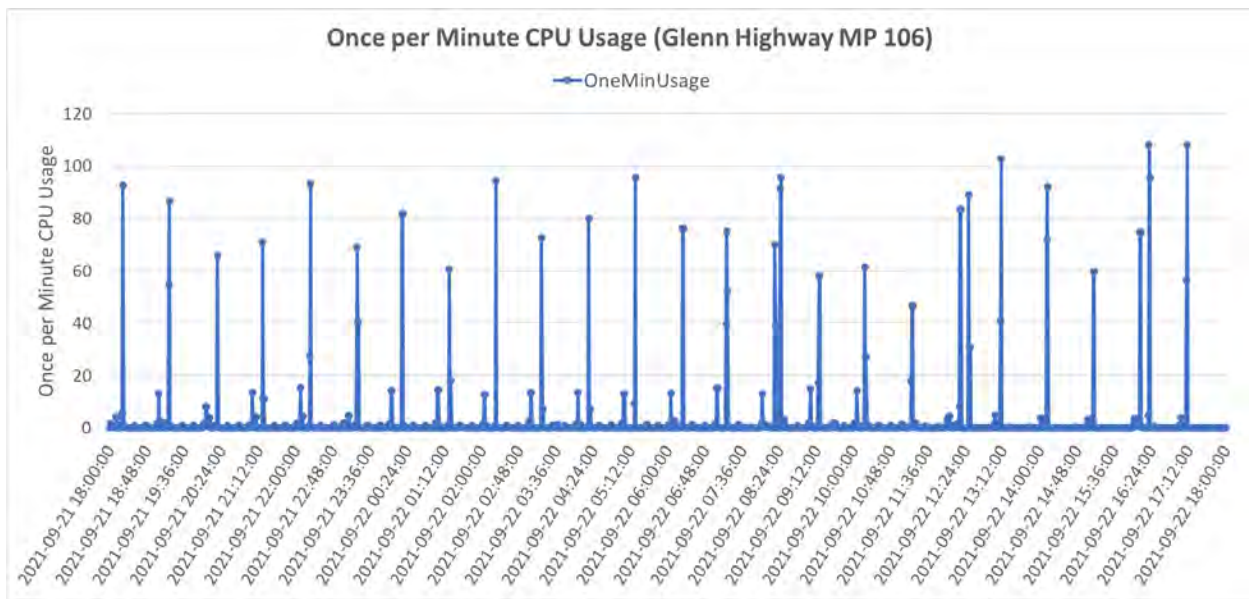

Figure 37: Plot of once per minute CPU usage (blue) for Glenn Highway MP 106 RWIS site from September 21, 2021 at 18:00 to September 22, 2021 at 18:00.

Hatcher Pass MP 15 (Logger 303)

Environmental data (ambient air temperature, road surface temperature, humidity, and wind speed) and operational data (average hourly, daily, and monthly power consumption and battery SoC and voltage) were obtained from the Hatcher Pass MP 15 RWIS system.

The average daily air temperature (Figure 38), daily power consumption with air temperature (Figure 39), and daily average battery SoC (Figure 40) were plotted from September 22, 2021 to January 3, 2022. The once per minute power consumption (Figure 41) and once per minute communications link activity (Figure 42) were plotted over a 24-hour period from September 26, 2021 at 18:00 to September 27, 2021 at 18:00 as a representative case.

The results showed that the RWIS station at Hatcher Pass MP 15 was able to measure, record, and communicate the daily average air temperature, road surface temperature, humidity, wind speed and direction, and other relevant meteorological data while consuming on average about 1.4 watts of power. Battery SoC was maintained at or near 100% until mid-December 2021 when the SoC started to drop likely due to the decrease in daylight hours, resulting in less time for the solar PV module to recharge the batteries (see Figure 40). The SoC continued to drop to around 96.5% on January 3, 2022, which was more than enough to maintain uninterrupted operation of the low-power RWIS. Peaks as high as 6.75 watts were observed at hourly intervals in the once per minute power demand (see Figure 41), which correspond to the communication link activity occurring once every hour (see Figure 42).

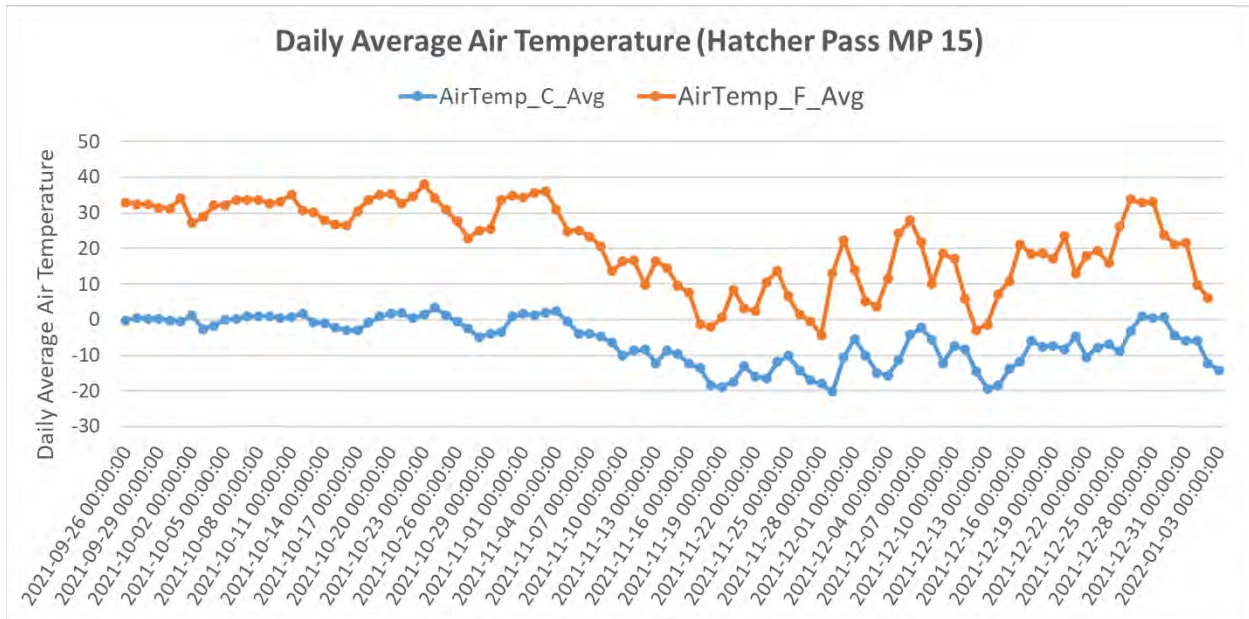

Figure 38: Plot of daily average temperature profile (°C: blue and °F: orange) for Hatcher Pass MP 15 RWIS site from September 26, 2021 to January 3, 2022.

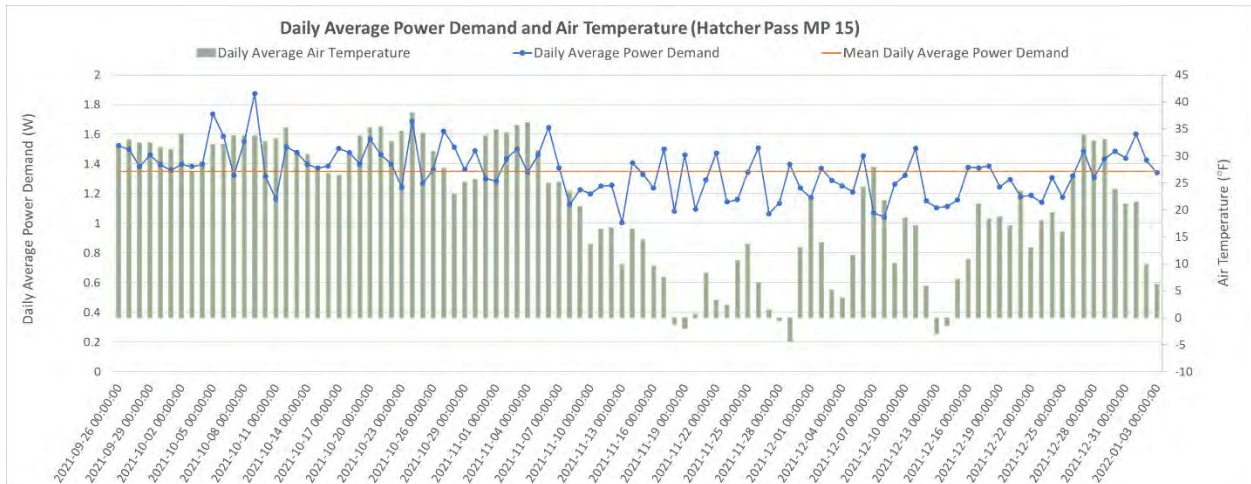

Figure 39: Plot of daily average power consumption (blue), air temperature (green), and mean power consumption (orange) for Hatcher Pass MP 15 RWIS site from September 26, 2021 to January 3, 2022.

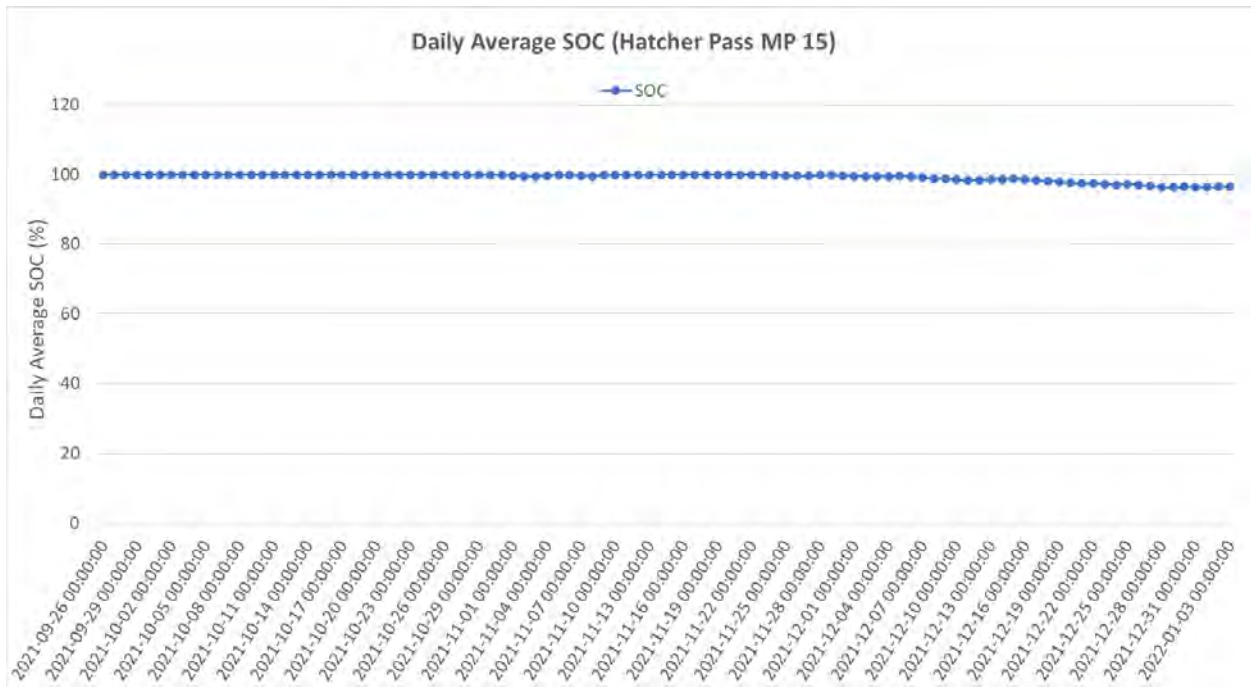

Figure 40: Plot of daily average SOC (blue) for Hatcher Pass MP 15 RWIS site from September 26, 2021 to January 3, 2022.

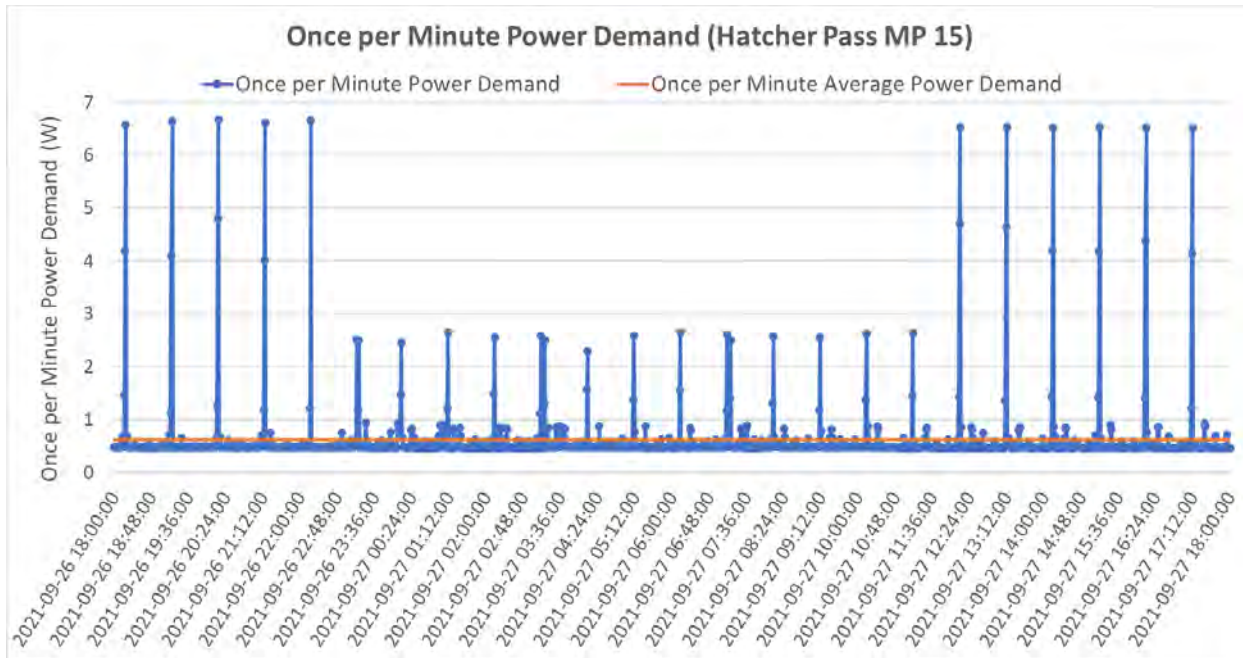

Figure 41: Plot of once per minute power consumption (blue) and mean power consumption (orange) for Hatcher Pass MP 15 RWIS site from September 26, 2021 at 18:00 to September 27, 2021 at 18:00.

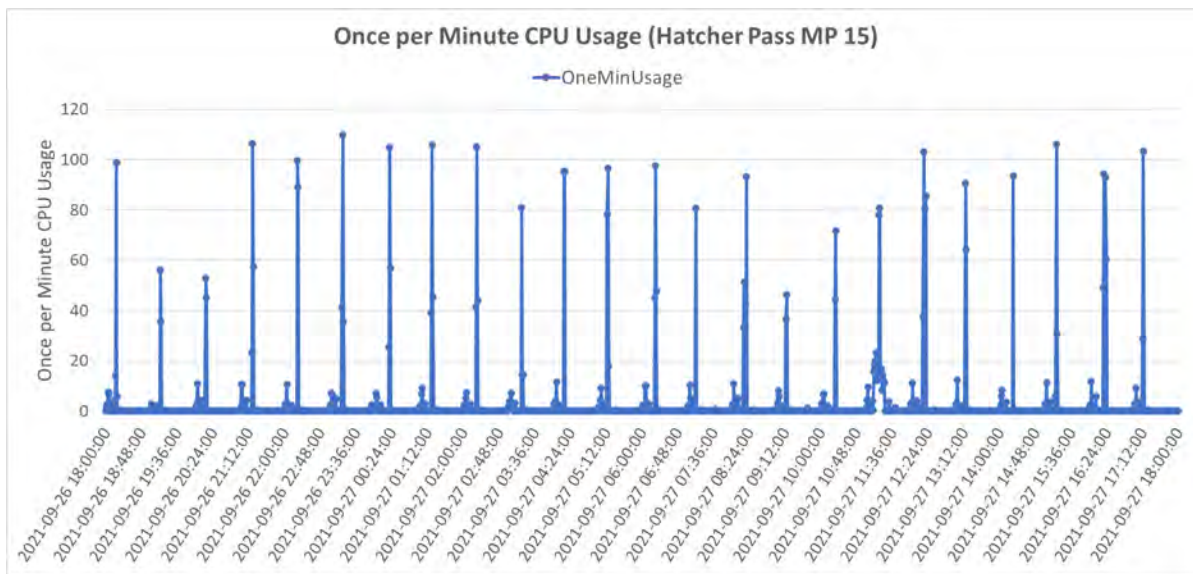

Figure 42: Plot of once per minute CPU usage (blue) for Hatcher Pass MP 15 RWIS site from September 26, 2021 at 18:00 to September 27, 2021 at 18:00.

GENERAL OBSERVATIONS

Campbell Scientific has been very responsive throughout the project. Even so, the initial startup was not without its difficulties. These are presented here not to downplay the abilities of Campbell Scientific. Rather overcoming these difficulties indicate the ability and desire of the company to adapt quickly.

CoVID-19 shut the project down the first winter due to travel restrictions in and out of Alaska and delays in shipping of equipment and batteries. GWScientific located in Fairbanks was hired to assist in the installation of the first three sites (Chena Hot Springs MP 10, Seward Highway MP 98.5, and Seward Highway MP 113.4) used in this study to work around CoVID-19 restrictions. GWScientific has a long history of installing Campbell Scientific equipment throughout Alaska including sites used by UAF scientists.

The equipment arrived in Fairbanks in May 2021 and was stored at UAF. GWScientific took possession of two of the systems. After inspecting the equipment GWScientific noted that the mounting system was inadequate for Arctic conditions recommending a more robust system to which Campbell Scientific agreed. Shortly thereafter, it was realized that the mounting system did not meet the requirements to be placed in the roadway clear zone. DOT&PF agreed to allow the RWIS to be placed behind the guardrail or outside the clear zone. Campbell continues to find a solution that will address this issue.

Shortly after the first three systems were installed, the team realized there were issues with the programming of the data loggers. These issues were resolved quickly by Campbell Scientific and GWScientific.

It was quickly recognized that a better system to move data from the RWIS to the State of Alaska public RWIS website was needed. Campbell Scientific developed a cloud-based system to collect and store the RWIS data. The system has been designed to easily interface with the DOT&PF RWIS website and other systems. As requested by DOT&PF and UAF the system can validate data and flag data that is not within anticipated values. The development of the cloud base data repository continues to evolve.

There were also issues with updates by one of the cell service providers. Given that the communication link between the RWIS and DOT&PF is of utmost importance in the operation of the system, upgrades to the cellular network that impact the operation of the cellular modem will need to be monitored to ensure that the systems are still able to upload data to the cloud.

Once the issues noted above were resolved, the system has proven to be robust with no downtime observed.

SUMMARY OF RESULTS AND CONCLUSIONS

The systems have proven to be reliable in both cold room and field testing. All seven of the systems deployed in the field have operated without failures. The power system has proven to be extremely robust with an estimated power reserve of nearly double the minimum required. However, it should be noted that to date, the camera heaters have not been employed. It would be useful to test that function during the 2022 winter.

The data collected during the 2021 field trials closely mimic the data collected in the cold rooms. This provides confidence that the systems will perform as expected. All instrumentation has performed

without problems with hoar frost or rime ice. However, there have been occasional issues with moisture on the camera lenses which degrade the images. To date, the heaters have not been employed to correct this issue since the degradation has been occasional. This may change as additional systems are installed.

Data values have been within the range anticipated. Unfortunately, we have no absolute comparisons other than those obtained in the cold rooms. The data collected in the cold rooms mimicked the cold room temperatures and relative humidity although the relative humidity at cold temperatures is 100%. A comparison of the two closest RWIS sites (Seward Highway MP 98.5 and Seward Highway MP 113.4) did show similar air temperatures and relative humidity, noting that one site is on the water side of the road while the other is on the cliff side of the road with different exposure to the prevailing winds and weather. It was also noted that the RWIS systems installed in northern locations experienced a lower battery %SoC than the systems in the more southern locations entering the winter season due to less sunlight for solar PV recharging. Of course, if additional equipment (meteorological sensors and/or camera heaters) are added to any of the RWIS sites, an even greater reduction in battery SoC would be observed.

The deployed RWIS systems will need to be monitored long term by AK DOT&PF for identification of any problems and development of practical solutions and future improvements by Campbell Scientific.

Appendix B: Station Locations and Station Design Schematics

AK Hwy MP 1285

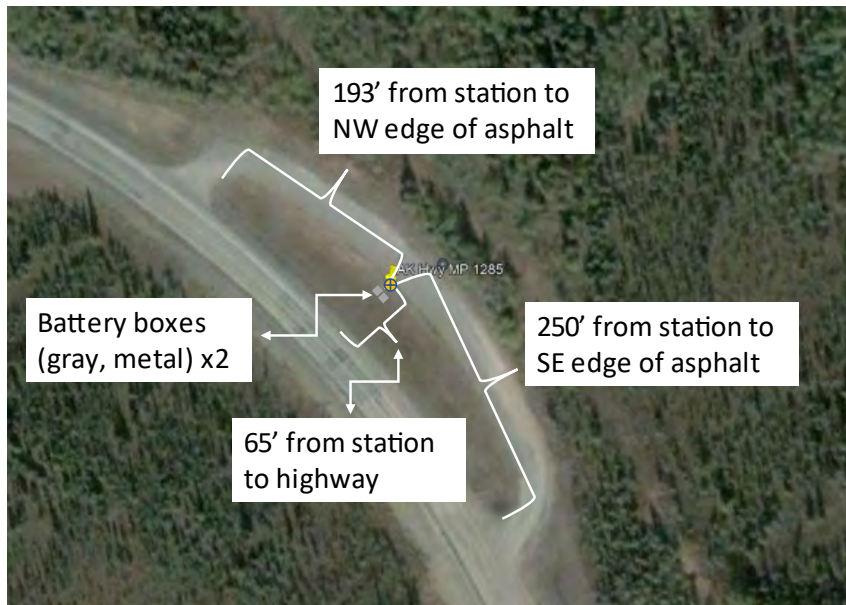

Lat: 63.201049 °
Long: -142.180904°

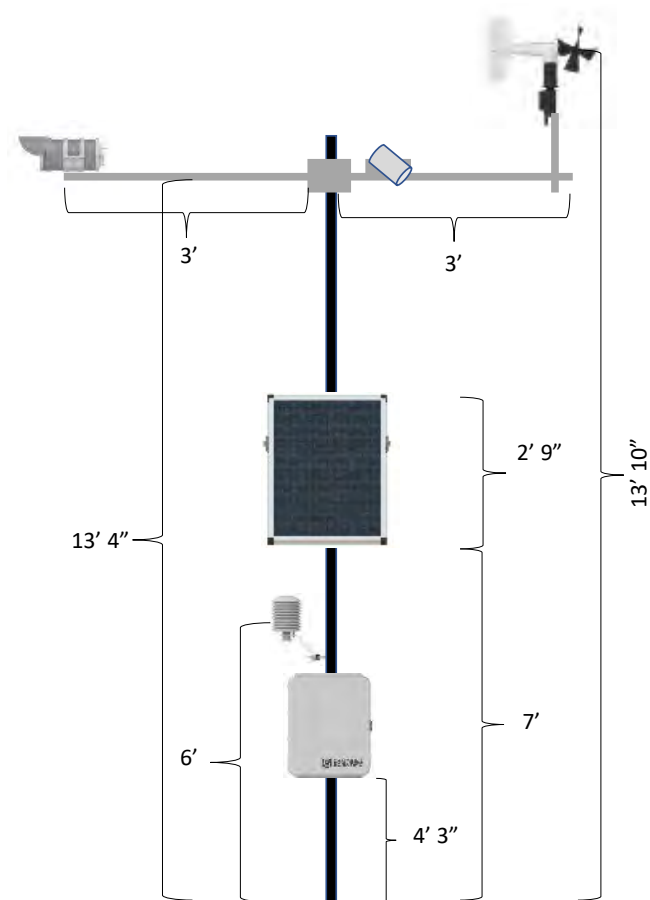

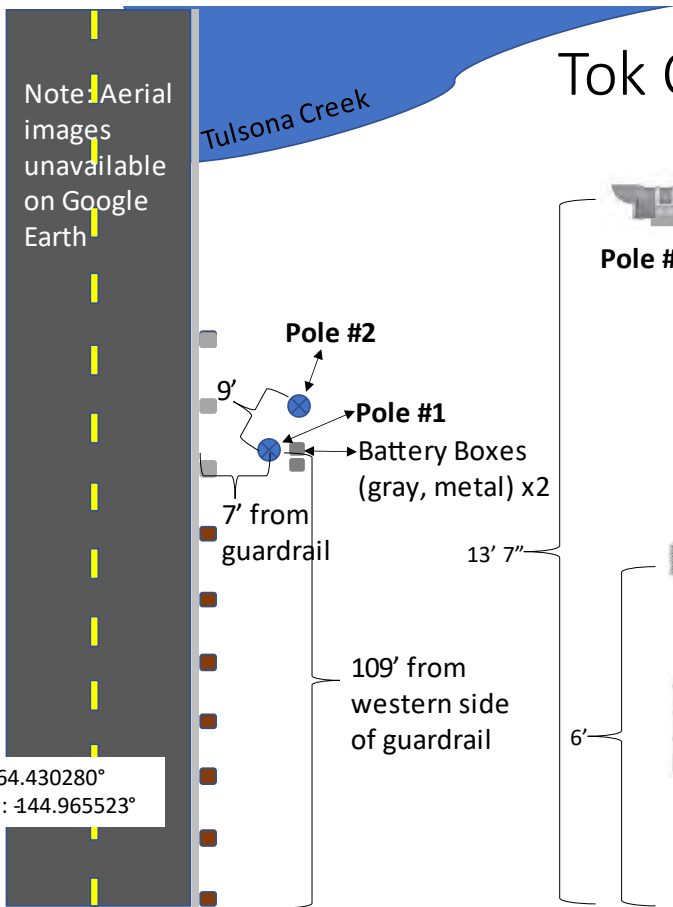

Tok Cutoff MP 17.5

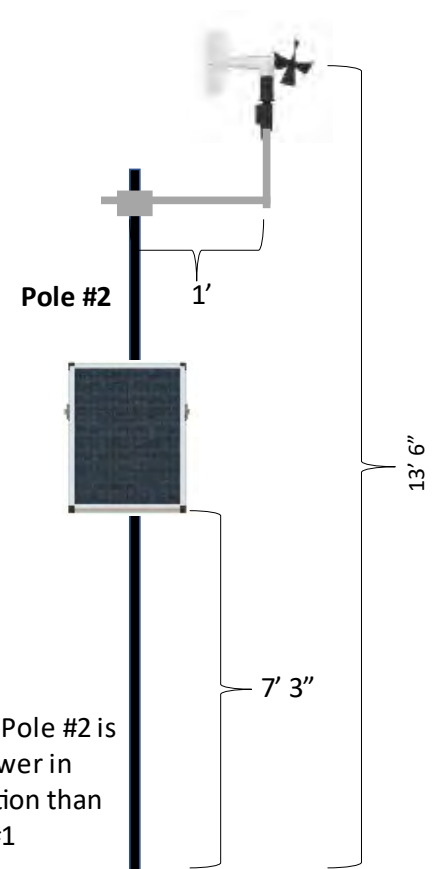
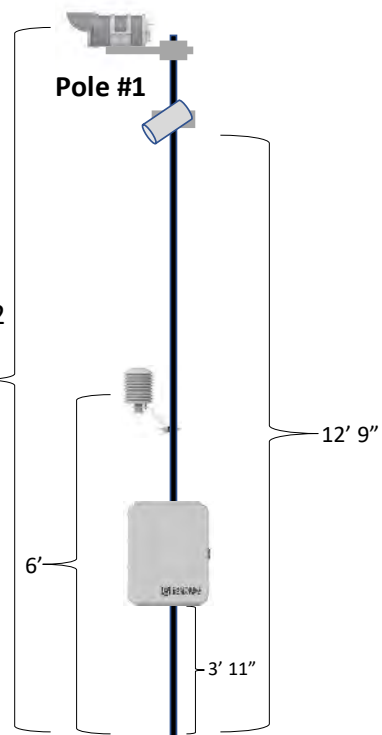



Glenn Hwy MP 106

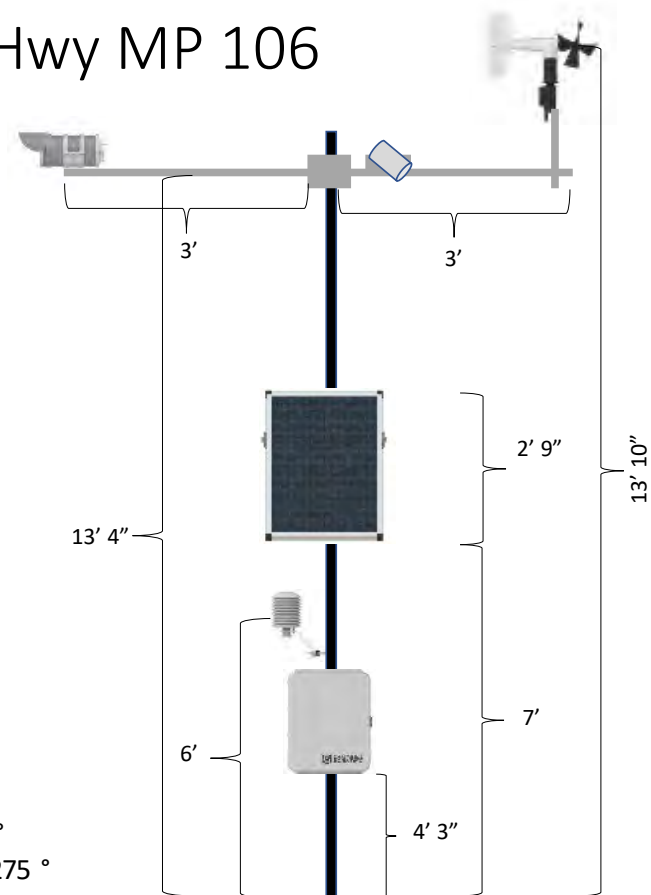

Lat: 61.793001 °
 Long: -147.672275 °



Hatcher Pass MP 15

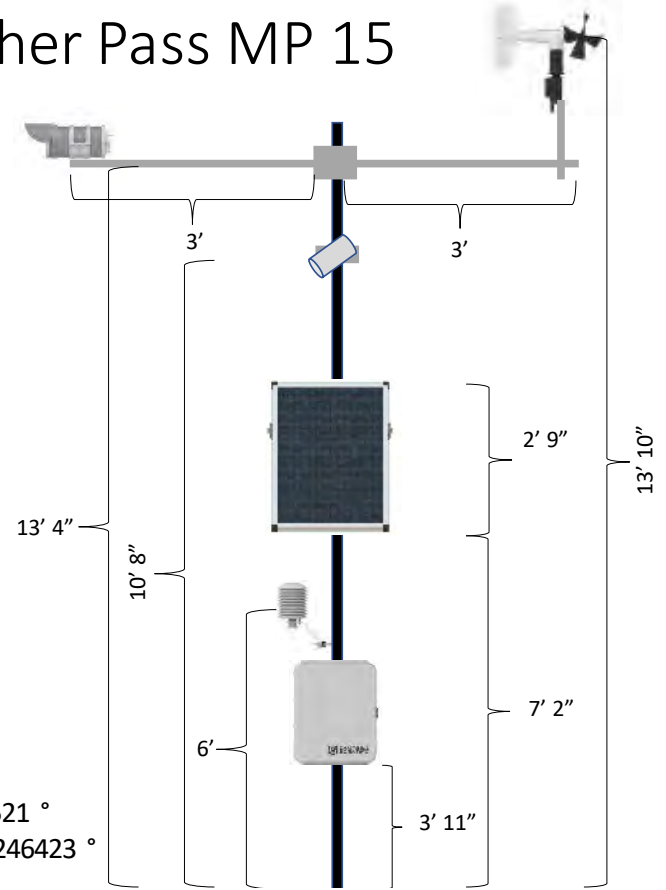

Chena Hot Springs Road @ Roberts Roost Road

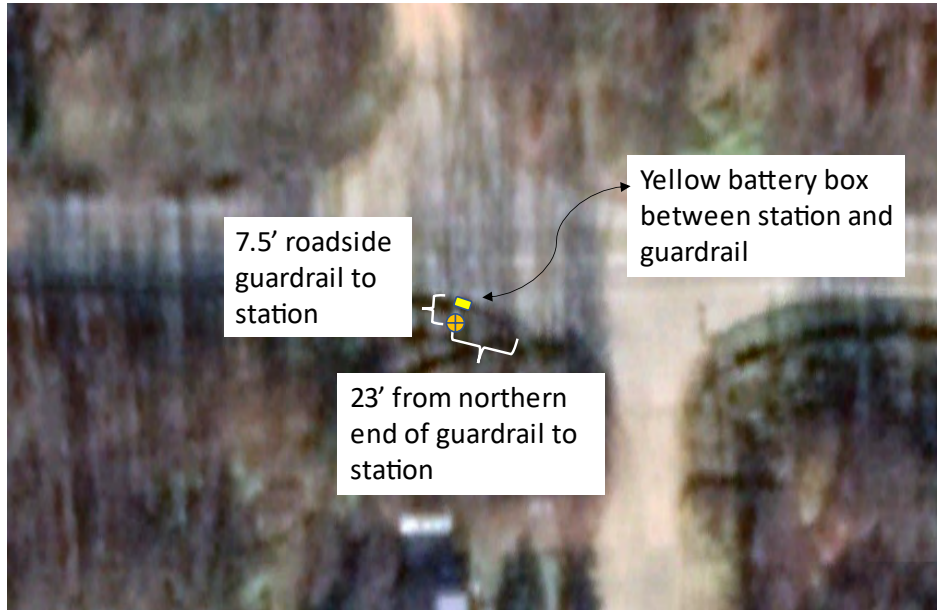

Lat: 64.884438 °
Long: -147.370037°

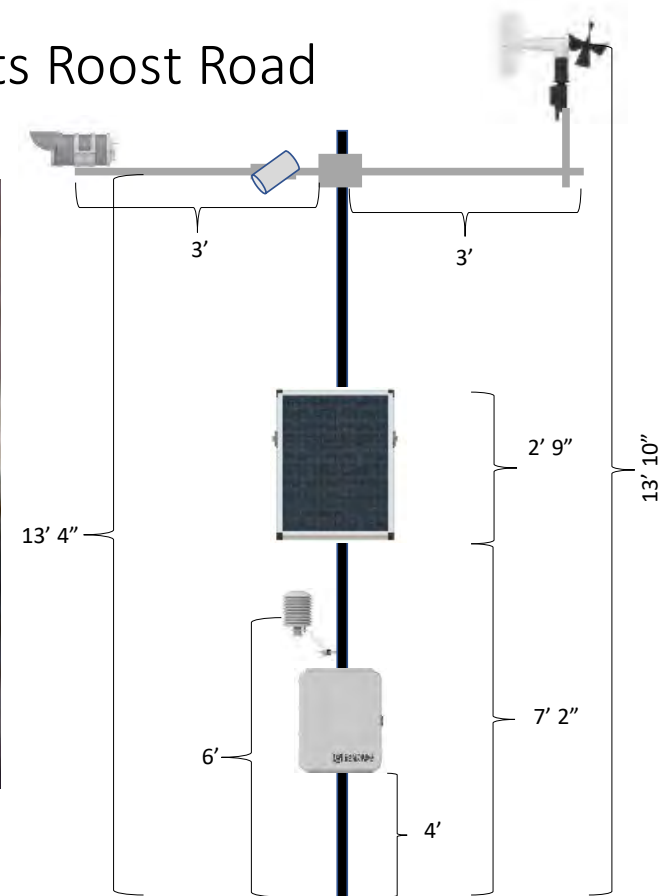

Seward Hwy MP 113.5

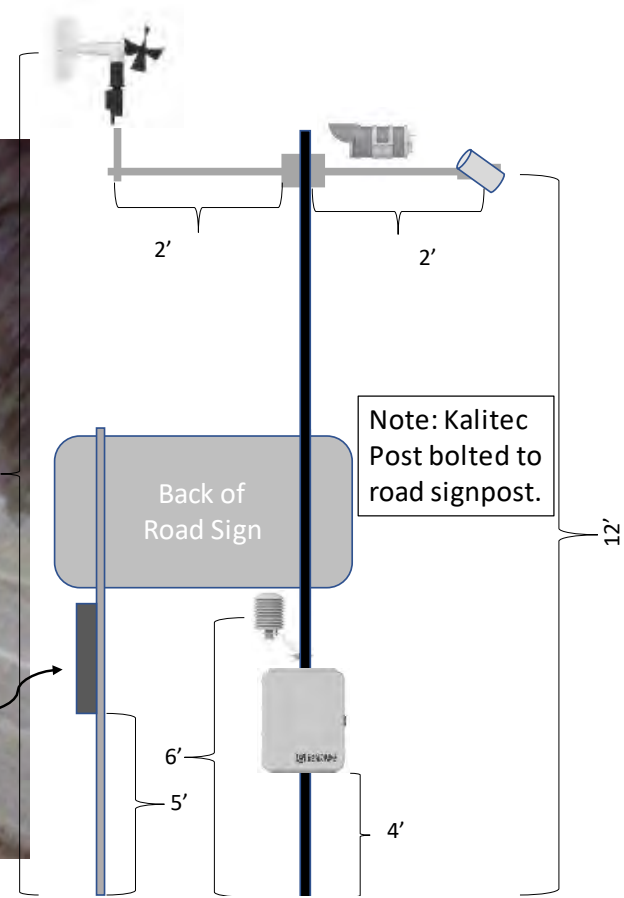
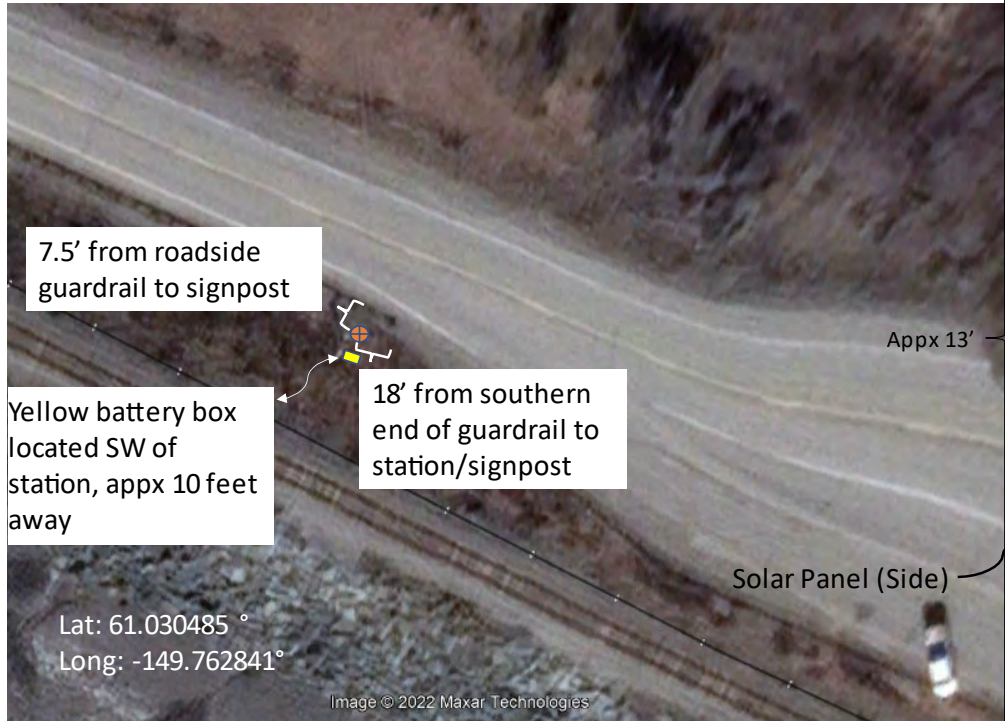

Seward Hwy MP 98.5

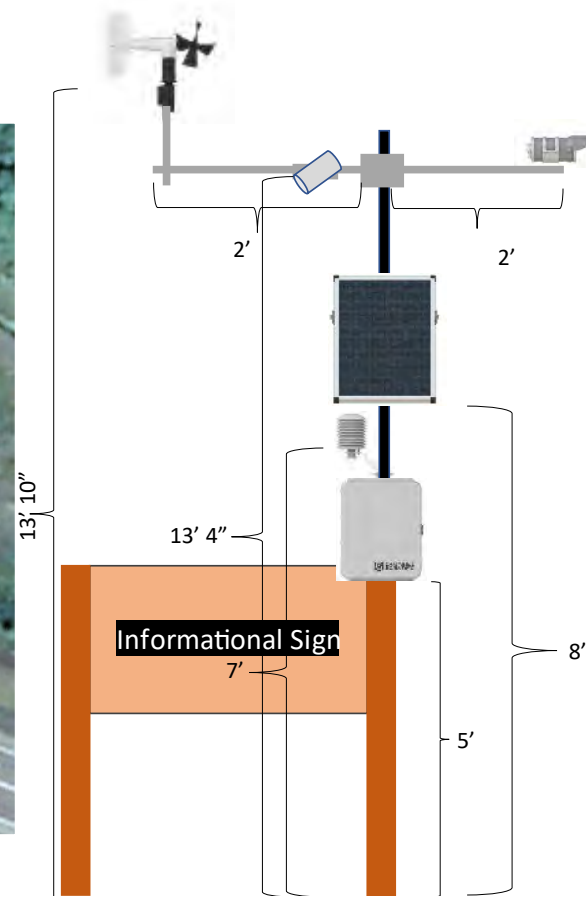

Appendix C: Site Photos



Chena Hot Springs Road @ Roberts Roost Road view looking east.



Chena Hot Springs Road @ Robert's Roost Road view looking W/SW.



Alaska Highway MP 1285 view looking southwest toward highway. Photo taken standing in rest area.



Alaska Highway MP 1285 view looking east from grassy area between highway and rest area.



Tok Cutoff MP 17.5 view looking southwest from roadway.



Tok Cutoff MP 17.5 view looking east toward Tulsona Creek.



Tok Cutoff MP 17.5 site. Telespar sign post bent likely from snowplow-thrown snow.



Glenn Highway MP 106 view looking north from highway.



Glenn Highway MP 106 view looking north.



Glenn Highway MP 106 view looking west.



Hatcher Pass MP 15 station being installed. View looking northeast toward avalanche area.



Hatcher Pass MP 15 completed station. View looking northeast toward avalanche area.



Hatcher Pass MP 15 view looking southeast from other side of highway.



Hatcher Pass MP 15: treated timbers used as solid base for yellow battery box.



Seward Highway MP 113.5 view looking northwest from pullout area.



Seward Highway MP 113.5: Kalitec Post bolted to sign post.



Seward Highway MP 113.5 battery box nestled snugly in wooded area.



Seward Highway MP 98.5: Kalitec post mounted to informational sign along rest area of walking trail.



Seward Highway MP 98.5 station view looking southeast toward walking trail and highway.



Seward Highway MP 98.5 station located at pullout along walking path.



Seward Highway MP 98.5 battery box located on grassy hill north of station.



Atigun Pass Station view looking toward highway. Photo courtesy Gordon Scott, ADOT.

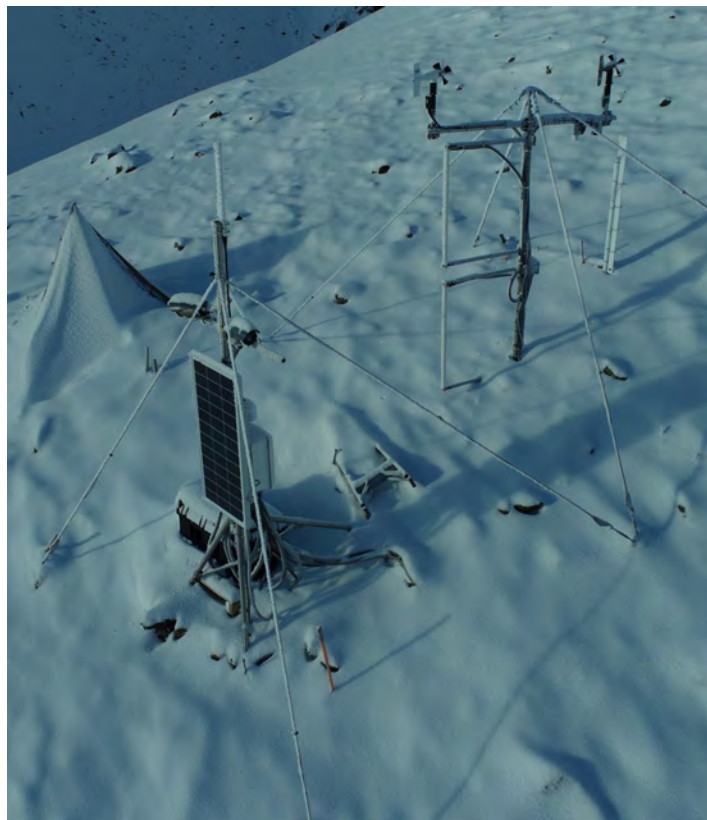

Atigun Pass Station view from UAS. Photo courtesy Gordon Scott, ADOT.

