

## A Performance-Based Highway Geometric Design Process

### DETAILS

0 pages | 8.5 x 11 | PAPERBACK

ISBN 978-0-309-45309-7 | DOI 10.17226/24626

BUY THIS BOOK

FIND RELATED TITLES

### AUTHORS

Timothy R. Neuman, Richard C. Coakley, Srikanth Panguluri, and Douglas W. Harwood; National Cooperative Highway Research Program; Transportation Research Board; National Academies of Sciences, Engineering, and Medicine

Visit the National Academies Press at [NAP.edu](http://NAP.edu) and login or register to get:

- Access to free PDF downloads of thousands of scientific reports
- 10% off the price of print titles
- Email or social media notifications of new titles related to your interests
- Special offers and discounts



Distribution, posting, or copying of this PDF is strictly prohibited without written permission of the National Academies Press. (Request Permission) Unless otherwise indicated, all materials in this PDF are copyrighted by the National Academy of Sciences.

© 2016 National Academy of Sciences. All rights reserved.

## ACKNOWLEDGMENTS

The research for this document was conducted through one or more programs administered by the Cooperative Research Programs (CRP) of the Transportation Research Board (TRB) of the National Academies of Sciences, Engineering, and Medicine:

- Airport Cooperative Research Program (ACRP) research is sponsored by the Federal Aviation Administration (FAA).
- Hazardous Materials Cooperative Research Program (HMCRP) research is sponsored by the Pipeline and Hazardous Materials Safety Administration (PHMSA).
- National Cooperative Freight Research Program (NCFRP) research is sponsored by the Office of the Assistant Secretary for Research and Technology.
- National Cooperative Highway Research Program (NCHRP) research is sponsored by the American Association of State Highway and Transportation Officials (AASHTO), in cooperation with the Federal Highway Administration (FHWA).
- National Cooperative Rail Research Program (NCRRP) research is sponsored by the Federal Railroad Administration.
- Transit Cooperative Research Program (TCRP) research is sponsored by the Federal Transit Administration (FTA) in cooperation with the Transit Development Corporation.

## COPYRIGHT INFORMATION

Authors herein are responsible for the authenticity of their materials and for obtaining written permissions from publishers or persons who own the copyright to any previously published or copyrighted material used herein.

Cooperative Research Programs (CRP) grants permission to reproduce material in this publication for classroom and not-for-profit purposes. Permission is given with the understanding that none of the material will be used to imply endorsement by TRB and any of its program sponsors of a particular product, method, or practice. It is expected that those reproducing the material in this document for educational and not-for-profit uses will give appropriate acknowledgment of the source of any reprinted or reproduced material. For other uses of the material, request permission from CRP.

## DISCLAIMER

To facilitate more timely dissemination of research findings, this pre-publication document is taken directly from the submission of the research agency. The material has not been edited by TRB. The opinions and conclusions expressed or implied in this document are those of the researchers who performed the research. They are not necessarily those of the Transportation Research Board; the National Academies of Sciences, Engineering, and Medicine; or the program sponsors.

The Transportation Research Board, the Academies, and the sponsors of the National Cooperative Highway Research Program do not endorse products or manufacturers. Trade or manufacturers' names appear herein solely because they are considered essential to the object of the report.

**This pre-publication document IS NOT an official publication of the Cooperative Research Programs; the Transportation Research Board; or the National Academies of Sciences, Engineering, and Medicine.**

Recommended citation: Neuman, T.R., R.C. Coakley, S. Panguluri, and D.W. Harwood. 2016. *A Performance-Based Highway Geometric Design Process*. Pre-publication draft of NCHRP Research Report 839. Transportation Research Board, Washington, D.C.

## Table of Contents

<b>Summary</b> .....	<b>1</b>
<b>1 Introduction</b> .....	<b>3</b>
<b>2 The Evolution of Highway Design in the US</b> .....	<b>5</b>
2.1 Up to the 1940s .....	5
2.2 The 1950s – The Technology of Highway Planning and Design Addresses Burgeoning Mobility Needs and National Public Policy Advances.....	5
2.3 The 1960s – The Growth of the Interstate System and Urban Transportation.....	6
2.4 The 1970s – Environmental Initiatives Drive National Transportation Policy and Programs .....	6
2.5 The 1980s – Transportation Professionals Wrestle with Reconstruction Needs and Congestion as Emerging Issues.....	7
2.6 The 1990s – Unsolved Problems of Congestion, Project Development, Community Sensitivity and Funding Begin to Take Their Toll .....	8
2.7 The 2000s to the present day – The Need for a New Highway Design Paradigm is Recognized.....	9
2.8 Recent Advances in Highway Design .....	9
2.8.1 Introduction .....	9
2.8.2 History and Evolution of the Highway Industry.....	22
<b>3 Highway Geometric Design and Project Development</b> .....	<b>26</b>
3.1 Introduction .....	26
3.1.1 Highway Design Decision-making.....	26
3.1.2 Transportation Values Addressed by the Process .....	28
3.1.3 Objective of the Design Process .....	29
3.1.4 The Legal Framework in which the Road and Highway Design Process Exists....	30
3.2 Key Findings on the Highway Design Development Process and Need for Design Process Changes.....	31
3.2.1 Finding No. 1 Interdisciplinary project development is here to stay (Institutionalization of Context Sensitive Solutions) .....	31
3.2.2 Finding No. 2 Context matters – and it varies .....	32
3.2.3 Finding 3 Providing multimodal solutions is now the rule and not the exception	36
3.2.4 Finding 4 AASHTO dimensional criteria should be ideally based on known and proven measurable performance effects.....	37
3.2.5 Finding 5 Speed is an essential input to determination of design values and dimensions.....	37
3.2.6 Finding 6 AASHTO Design Criteria produce uneven outcomes re: performance	38
3.2.7 Finding 7 Many AASHTO criteria are not sensitive to key context attributes that are proven influencers of performance and cost-effectiveness .....	38
3.2.8 Finding 8 Some AASHTO criteria are unnecessarily simplistic in their formulation, or are based on models that are lacking a proven science basis ...	43
3.2.9 Finding 9 The legal framework requires the provision of threshold limits for design criteria and design values; the question is – how should such lower limits be set?.....	43
3.2.10 Finding 10 Nominal and Substantive Safety Differ in Meaningful Ways.....	45
3.2.11 Finding 11 AASHTO criteria should more completely reflect known interactive safety and operational effects of geometry .....	47

3.2.12	Finding 12 Replace dimensional guidance with direct performance guidance where possible within the AASHTO Policy .....	47
3.2.13	Finding 13 Advances in technology should be incorporated into the geometric design process .....	48
3.2.14	Finding 14 The notion of ‘conservatism’ in policy and leadership in the highway engineering field needs a 180 degree shift .....	51
3.2.15	Finding 15 Geometric design should be understood, taught, executed and communicated as iterative in nature with performance at the center of all iterations and optimizing.....	52
3.2.16	Finding 16 More explicitly incorporate maintenance and operation costs .....	52
3.3	References .....	52
<b>4</b>	<b>Guiding Principles for an Effective 21<sup>st</sup> Century Highway Design Process .....</b>	<b>55</b>
4.1	Fundamental Bases for Roadway Design.....	55
4.1.1	Geometric Design Solutions Should Address Objective, Quantitative Measures of Transportation Performance .....	55
4.1.2	The Geometric Design Process Should Explicitly Address All Potential, Legal Road Users .....	57
4.1.3	The Geometric Design Process Should Integrate Operational Solutions with Geometric Elements .....	58
4.1.4	The Design Process is Forward Looking.....	61
4.1.5	The Design Process Must Be Context Sensitive to the Extent Possible.....	62
4.1.6	The Design Process Must Be Financially Sustainable at Both the Program and Project Level .....	63
4.2	The Design Process Must Be Conducted within the Prevailing Social and Public Policy Framework.....	64
4.2.1	Accountability and Responsibility.....	64
4.2.2	Legal Framework .....	65
4.2.3	The Design Process Should Support the Financial Sustainability of the Agency’s Program .....	70
4.3	Attributes of an Effective Geometric Design Process.....	72
4.3.1	Efficiency.....	72
4.3.2	Scalability.....	73
4.3.3	Executable .....	73
4.3.4	Transparency and Defensibility .....	73
4.4	References .....	74
<b>5</b>	<b>Recommended Highway Design Process .....</b>	<b>77</b>
5.1	Step 1 – Define the Transportation Problem or Need.....	77
5.2	Step 2 – Identify and Charter All Project Stakeholders .....	79
5.2.1	Internal Agency Stakeholders .....	80
5.2.2	External Agency Stakeholders .....	80
5.2.3	Other External Stakeholder Groups or Agencies.....	80
5.2.4	Directly Affected Stakeholders .....	81
5.2.5	Stakeholder Chartering.....	81
5.3	Step 3 – Develop the Project Scope.....	81
5.3.1	Refinement and Confirmation of Problem or Needs Statement.....	82
5.4	Step 4 – Determine the Project Type and Design Development Parameters .....	82
5.4.1	Unique Characteristics of New Roads .....	83
5.4.2	Unique Characteristics of Reconstruction Projects .....	83
5.4.3	Unique Characteristics of 3R Projects .....	85
5.4.4	Project Types and Transportation Problems .....	85

5.4.5	Setting of Project Limits and Major Study Parameters or Controls .....	86
5.4.6	Determining Environmental Process and Documentation Requirements .....	86
5.4.7	Establishment of Planning Level Implementation Budget .....	86
5.5	Step 5 – Establish the Project’s Context and Geometric Design Framework .....	87
5.5.1	Framework for Geometric Design Process - New Construction and Reconstruction.....	87
5.5.2	Develop Project Evaluation Criteria within the Context Framework .....	101
5.5.3	Establish Decision-making Roles and Responsibilities.....	103
5.5.4	Determine Basic Geometric Design Controls – Design or Target Speed .....	104
5.5.5	Determine Basic Design Controls -- Design Traffic Volumes .....	106
5.5.6	Determine Basic Design Controls -- Design Level of Service (or Operating Condition) .....	110
5.5.7	Determine Basic Design Controls – Road User Attributes.....	111
5.6	Step 6 -- Apply the Appropriate Geometric Design Process and Criteria .....	113
5.6.1	Roads on New Alignment Are Designed with a Unique Process and Criteria ...	114
5.6.2	Design of Projects Involving Existing Roads.....	114
5.6.3	Develop Project Technical Approach.....	118
5.7	Step 7 – Designing the Geometric Alternatives.....	119
5.7.1	Assemble an Inclusive and Interdisciplinary Team.....	119
5.7.2	Focus on and Address the Need or Solve the Problem(s) within the Context Conditions and Constraints .....	119
5.8	Step 8 – Design Decision-making and Documentation.....	124
5.8.1	Independent Quality and Risk Management Processes .....	124
5.9	Step 9 – Transitioning to Preliminary and Final Engineering.....	127
5.9.1	Technology Applications -- Building Information Modeling.....	128
5.10	Step 10 – Agency Operations and Maintenance Database Assembly.....	131
5.11	Step 11 – Continuous Monitoring and Feedback to Agency Processes and Database ..	131
5.12	References .....	132
<b>6</b>	<b>Updating the Technical Guidance on Geometric Design in the AASHTO Policies .....</b>	<b>134</b>
6.1	Overview of contents of 2011 AASHTO Policy on Geometric Design.....	134
6.2	Lane and Travelled Way Widths .....	136
6.3	Shoulder Widths .....	138
6.3.1	Framework for Design Criteria Development – Lane Width and Shoulders .....	140
6.3.2	Local Roads in Rural Contexts.....	140
6.3.3	Collector Roads and Arterials in Rural Contexts .....	141
6.3.4	Urban non-freeway Roads.....	141
6.3.5	Urban Freeways.....	141
6.4	Roadside Design.....	142
6.5	Alignment and Sight Distance.....	142
6.5.1	Horizontal Curvature .....	142
6.5.2	Summary of Revised Approach to Horizontal Curve Design .....	151
6.6	Sight Distance .....	152
6.6.1	Critique of AASHTO Sight Distance Design Policy and Models.....	153
6.6.2	Potential Approaches to Sight Distance Design Policy .....	155
6.7	Vertical Alignment .....	157
6.7.1	Grade .....	157
6.7.2	Crest Vertical Curvature .....	159
6.8	Vertical Clearance.....	162
6.9	Medians and Access Control.....	163
6.10	References .....	163

<b>7</b>	<b>Value and benefits of improved process.....</b>	<b>167</b>
7.1	Introduction .....	167
7.2	Case studies .....	168
7.2.1	Case Study 1.....	168
7.2.2	Case Study 2.....	171
7.2.3	Case Study 3.....	178
7.2.4	Case Study 4.....	181
7.2.5	Case Study 5.....	193
7.2.6	Case Study 6.....	194
<b>8</b>	<b>Research and knowledge needs to fully implement the revised process.....</b>	<b>199</b>
8.1	AASHTO Curve model .....	199
8.2	AASHTO SSD Model .....	199
8.3	O&M Understanding related to Geometric design elements .....	200
	<b>Further research and study.....</b>	<b>200</b>
8.4	Challenges with new process.....	200
8.4.1	Summary of Potential Design Processes .....	201
8.4.2	Challenges to Implementing a Revised Geometric Design Process.....	201
8.4.3	Organizational and Institutional .....	202
8.4.4	Risk Management .....	203
8.4.5	Scalability for Owner, Roadway and Project Size .....	203
8.4.6	Professional .....	203
8.4.7	A State’s Experience Implementing a Flexible Design Process.....	204
8.4.8	Lessons Learned from Recent Process Changes.....	205
8.5	Green Book Reorganization .....	206
8.5.1	A Future Generation AASHTO Policy on Geometric Design .....	207
8.6	Implications with driverless/connected/autonomous technology .....	208
	<b>Appendix A: Example Performance Criteria Memorandum .....</b>	<b>A-1</b>
	<b>Appendix B: Review of the 2011 AASHTO Policy on Geometric Design.....</b>	<b>B-1</b>
	<b>Appendix C: Horizontal Curve Analysis .....</b>	<b>C-1</b>
	<b>Appendix D: Operations and Maintenance Considerations for Geometric design.....</b>	<b>D-1</b>
	<b>Appendix E: The Future AASHTO Green Book .....</b>	<b>E-1</b>

## Tables

<b>Table 1. Performance Measures Used to Determine Level of Service in the HCM.....</b>	<b>13</b>
<b>Table 2. Guidelines for Selection of Design Levels of Service in the Green Book.....</b>	<b>13</b>
<b>Table 3. Geometric Design Elements in Current HSM Chapters .....</b>	<b>14</b>
<b>Table 4. CMF for Lane Width on Roadway Segments (CMF<sub>ra</sub>).....</b>	<b>14</b>
<b>Table 5. Overlap of Alternative Design Concepts .....</b>	<b>21</b>
<b>Table 6. Example of Performance-Based Criteria from Current AASHTO Green Book .....</b>	<b>36</b>
<b>Table 7. AASHTO Criteria Evaluation.....</b>	<b>40</b>
<b>Table 8. National Environmental Policy Act Legal and Regulatory “Umbrella” .....</b>	<b>68</b>
<b>Table 9. Summary of Safety, Operations, and Environmental Tools Used in the Design Process.....</b>	<b>72</b>
<b>Table 10. Geometric Design Guidance for Roads and Highways in Rural Natural Zones.....</b>	<b>94</b>
<b>Table 11. Geometric Design Guidance for Roads and Highways in Rural General Zones .....</b>	<b>96</b>
<b>Table 12. Geometric Design Guidance for Roads and Highways in Suburban Zones .....</b>	<b>97</b>
<b>Table 13. Geometric Design Guidance for Roads and Highways in Urban General Zones.....</b>	<b>98</b>
<b>Table 14. Geometric Design Guidance for Roads and Highways in Urban Center Zones.....</b>	<b>99</b>
<b>Table 15. Geometric Design Guidance for Roads and Highways in Urban Core Zones.....</b>	<b>100</b>
<b>Table 16. Target Speeds for Urban Context Zones by Highway Type .....</b>	<b>106</b>
<b>Table 17. Guidelines for Assignment of Service Life for Roadway Infrastructure Projects.....</b>	<b>109</b>
<b>Table 18. Design and Traffic Control Measures to Address Driver Expectations .....</b>	<b>120</b>
<b>Table 19. Crash Modification Factor for Lane and Shoulder Widths .....</b>	<b>138</b>
<b>Table 20. Crash Modification Factors (CMF) for Shoulder Types and Shoulder Widths on Roadway Segments .....</b>	<b>138</b>
<b>Table 21. Effectiveness of Shoulder Widths for Shoulder Functions .....</b>	<b>139</b>
<b>Table 22. Effect of No Passing Zones.....</b>	<b>154</b>
<b>Table 23. PCEs for Trucks and Buses on Specific Grades .....</b>	<b>158</b>
<b>Table 24. Crash Modification Factors for Grade of Roadway Segments .....</b>	<b>158</b>
<b>Table 25. Bicycle Gradability.....</b>	<b>159</b>
<b>Table 26. Case Study 1, Traffic Analyses Results .....</b>	<b>169</b>
<b>Table 27. Case Study 1, Crash Study Results.....</b>	<b>170</b>
<b>Table 28. Crash Analyses Input Values .....</b>	<b>170</b>
<b>Table 29. Control delay and level of service for each movement at the freeway ramp terminals for existing and proposed conditions in the design year, 2025. ....</b>	<b>174</b>
<b>Table 30. Crashes by segment type and severity level for existing conditions in design year 2025. ....</b>	<b>176</b>
<b>Table 31. Crashes by segment type and severity level for proposed realignment in design year 2025. ....</b>	<b>176</b>
<b>Table 32. Case Study 3 Traffic Analyses Results .....</b>	<b>179</b>
<b>Table 33. Case Study 3 Crash Analyses Results.....</b>	<b>179</b>
<b>Table 34. Predicted crashes by severity level for segments and intersections along the existing highway alignment in design year 2040.....</b>	<b>187</b>
<b>Table 35. Predicted crashes by severity level for segments and intersections along the existing US 4th proposed highway alignment (bypass) and “Old Highway” in design year 2040.....</b>	<b>187</b>
<b>Table 36. LOS Assessment for Roadway Segments in the Existing and Proposed Alternatives for the Design Year 2040.....</b>	<b>190</b>
<b>Table 37. Case Study 5, Traffic Analyses Results .....</b>	<b>194</b>

## Figures

Figure 1. Crash Modification Factor for Lane Width on Roadway Segments .....	15
Figure 2. Typical Observed and Predicted Total, FI, and PDO Crash Rates vs. Traffic Density (ref to L07 report) .....	18
Figure 3. Costs and Right-of-way Dominate Design Decisions .....	27
Figure 4. Roadway Context Zones.....	33
Figure 5. Adverse Effects of Speed on Safety Performance .....	37
Figure 6. Comparison of Actual vs Assumed Driver Speed Behavior by AASHTO Curve Design Model .....	44
Figure 7. What is Acceptable Risk as the Basis for Design Criteria? .....	44
Figure 8. The Two Dimensions of Safety .....	46
Figure 9. A Decision Matric Based on the Two Dimensions of Safety.....	46
Figure 10. Dimensioned Minimum Ramp Terminal Spacing .....	48
Figure 11. Drafting Machine. Source: Technical Drawing, Seventh Edition, 1980.....	49
Figure 12. CAD Work Environment, 2015 .....	49
Figure 13. ProjectWise: A Change in Construction. Source: <a href="https://www.bentley.com/en/project-profiles/michigan-department-of-transportation_projectwise-a-change-in-construction">https://www.bentley.com/en/project-profiles/michigan-department-of-transportation_projectwise-a-change-in-construction</a> .....	50
Figure 14. A Performance-based, Iterative Design Process.....	51
Figure 15. Two Mental Models for Safety in Design .....	56
Figure 16. Value Proposition: Reliable Travel Time .....	59
Figure 17. Smarter Highways variable speed limits .....	59
Figure 18. Qualitative Demonstration of Tradeoffs for Cross Section Alternatives Incorporating Varying Lane and Shoulder Width Strategies and ITS.....	60
Figure 19. Transit Service Operation on Freeway Shoulders in Minneapolis.....	61
Figure 20. Sustainability of Highway Trust Fund .....	63
Figure 21. Allocation of 2013 Annual Budget for the Missouri DOT .....	71
Figure 22. Roadway Design Development Process .....	77
Figure 23. The Steps of the Recommended Highway Design Process.....	78
Figure 24. Project Types and Transportation Problems .....	85
Figure 25. Geometric Design Context Framework .....	87
Figure 26. Roadway Context Zones.....	88
Figure 27. Profile of Fatal and Injury Crashes by Type for ITE Context Zones for Cook County IL.....	91
Figure 28. Generalized Profile of Typical or Critical Operational Issues Governing Geometric Design by Context .....	93
Figure 29. Generalized Profile of Typical or Critical Substantive Safety Issues Governing Geometric Design by Context .....	93
Figure 30. Traffic Assignment Periods Employed by the Chicago Metropolitan Agency of Planning (CMAP).....	107
Figure 31 Agency Costs - Transportation Benefits .....	109
Figure 32. Level of Service Definitions for Road Types (Source: HCM Exhibit 2-2 and 2-3) .....	111
Figure 33. Problem-based Unified Geometric Design Process .....	114
Figure 34. Fuel Costs (Cents per Mile) by Speed – Automobiles ref figure 5-1 User Benefit Analysis for Highways AASHTO 2003 .....	116
Figure 35. Hierarchy of Roadway Design Decisions and Their Relative Importance .....	121
Figure 36. The Continuum of Geometric Design.....	122
Figure 37. Tailoring of the Design Approach and Deliverables to the Major Project Phases.....	122
Figure 38. Tailoring the Technical Approach of Performance Evaluation to the Phase of Alternatives Development .....	123
Figure 39. BIM Output to Evaluate Sight Lines along Curved Roadway with Barrier .....	130
Figure 40. Crash Modification Factor for Lane Widths on Freeways. Source: HSM.....	137
Figure 41. Straw man Framework for Design of Lane Widths for Road Types by Context. ....	140
Figure 42. Curve Geometry .....	144



**Figure 43. Potential Crash Effect of the Radius, Length, and Presence of Spiral Transition Curves in a Horizontal Curve ..... 145**

**Figure 44. Potential Bases for Development of Horizontal Alignment Policy ..... 150**

**Figure 45. Straw man Proposal for Design of Horizontal Curvature for Road Types by Context ..... 152**

**Figure 46. Straw man Proposal Framework for Design of Sight Distance for Road Types by Context ..... 156**

**Figure 47. Stopping Sight Distance Profiles ..... 157**

**Figure 48. Cross-section without bike lanes (top) and cross-section with bike lanes (bottom)..... 169**

**Figure 49. Existing interchange alignment. .... 172**

**Figure 50. Proposed redesign of interchange, including new entrance loop ramp in southwest quadrant.172**

**Figure 51. Design year traffic volumes for existing interchange configuration..... 173**

**Figure 52. Design year peak hour turning movement counts for planned interchange reconfiguration. ... 173**

**Figure 53. Cross-section before 3R improvement (top) and cross-section with improvement (bottom).... 178**

**Figure 54. Two horizontal curves with existing and proposed alignments ..... 179**

**Figure 55. Map of existing conditions overlaid with drawing of proposed highway realignment. .... 182**

**Figure 56. 2009 peak hour volumes and ADT at intersections along existing Highway..... 183**

**Figure 57. Proposed typical cross section for proposed alignment of highway (bypass). .... 186**

**Figure 58. Case Study 5, Alternative 1 Typical Section..... 193**

**Figure 59. Case Study 5, Alternative 2 Typical Section..... 193**

**Figure 60. Case Study 6 Location Map..... 195**

**Figure 61. Understanding Financial Impact and Ease of Implementation for Individual Design Criteria and Policies ..... 205**

**Acronyms and Abbreviations**

AADT	average annual daily traffic
AASHO	American Association of State Highway Officials (Predecessor to AASHTO)
AASHTO	American Association of State Highway and Transportation Officials
ADA	Americans with Disabilities Act
ATC	alternative technical concept
B/C	benefit to cost
BIM	Building Information Modeling
CEVP	cost-estimating validation processes
CMAP	Chicago Metropolitan Agency of Planning
DB	Design Build
DHV	design hourly volume
DSD	decision sight distance
DOT	Department of Transportation
FHWA	Federal Highway Administration
HCM	Highway Capacity Manual
HSM	Highway Safety Manual
I	Interstate
ISD	intersection sight distance
ITE	Institute of Transportation Engineers
ITS	intelligent transportation system
LOS	level of service
M&O	maintenance and operating
MSD	Maneuver Sight Distance
N/A	not applicable
NCHRP	National Cooperative Highway Research Program
NEPA	National Environmental Policy Act
No.	Number
O&M	operation and maintenance
PC	point of curvature
PSD	passing sight distance
PSI	potential for safety improvement
RSA	road safety audit
SSD	stopping sight distance
TRB	Transportation Review Board
VE	value engineering
VLVLR	very low volume local roads
vpd	vehicles per day
wt/hp	weight to horsepower



## Summary

The typical purpose of geometric design process is to provide the necessary three-dimensional features for a roadway to address the stakeholder identified problems or needs by providing the appropriate level of mobility and/or safety improvements for all the road users. Historically, the highway design process has followed AASHTO, and the AASHTO policies starting in 1940s. Geometric design involves the application of tools, methods, dimensions, and criteria. Dimensional design standards and criteria are a means to an end. The tools used in the current process have been dimensionally based and designers typically follow the values in tables and equations in the AASHTO or agency policies. The traditional philosophical approach to design has been to treat minimum design criteria as adequate to produce acceptable performance. The goal has been to meet these standards or criteria rather than to specifically provide sustainable traffic operations and safety. Some of the dimensions or models included in the AASHTO policy have not changed much over the decades. The typical updates of the AASHTO policies and guides have been focused on the various individual design elements, and not focused on the overall design process. An assessment of the existing design process was undertaken to suggest changes to ensure that recent advances in knowledge and emerging issues are incorporated in the design process.

In recent years strong stakeholder interest has emerged. A geometric design process that is responsive to these issues requires measurable transportation or environmental impact terms. This dialogue between design professionals and stakeholders is essential for developing an optimal solution, balanced with transportation and community goals.

The transportation knowledge base has grown over the years. The research findings propose that the end goal of all the geometric designs need to be measured in the metrics of transportation performance, including mobility, accessibility, safety, maintenance & operations, and state-of-good repair. Every phase, methodology, or model developed and applied to conducting the highway design and establishing the highway design criteria should be objectively related to one or more measures of transportation performance. A change to the current AASHTO Green Book as defined by location and functional classification is proposed. The revised geometric design process as part of this report provides guidelines based on the project type and the problem or need being addressed. A potential outline to a new policy is developed and provides direction to use the categories of new construction, reconstruction of an existing route, or rehabilitation of an existing facility as the basis of geometric design. The geometric design criteria for any given project is recommended to be based on the context of the project location, and not limited to the facility type. This revised highway design process is intended for further development to become fully implementable.

Additional knowledge gaps are identified as part of this research. A more robust range of definitions of land uses will address the requirements of the users and surrounding development that the roadway will serve. The AASHTO policy serves as the basis for the design manuals of the state DOTs. These documents will need to be updated to make them consistent with the revised geometric design process. This could include a supplemental recommendation process guide as a companion to the design policies, minor changes to the policies, or a completely new structure to the policies.



# 1 Introduction

The design of a highway—its three-dimensional features (horizontal alignment, vertical alignment, and cross-section) and appurtenances to provide for drainage, traffic control, and safety—requires a well-defined process. AASHTO and its predecessor, AASHO, have published highway design policy since the 1940s; the underlying highway design process has remained essentially unchanged since that time. That process has the following characteristics:

- Dimensionally based, with design values for physical dimensions directly derived from tables, charts, and equations.
- Requires establishment of fundamental design controls including location, terrain, and functional classification.
- Requires designers to make choices for other major factors (e.g., design speed, design hour volume, design vehicle) that will influence subsequent design decisions from within established ranges.
- Based on selection of a design speed, and in some cases design vehicular traffic volume, other design criteria are directly derived or obtained for minimum dimensions (e.g., lane width, curve radius) and/or maximum dimensions (e.g., grade) as appropriate for the design controls and assumptions.
- Direct performance measures in terms of vehicle mobility, including speed and level of service, are explicitly considered in some design decisions (e.g., number of lanes).
- Costs versus benefits are also an integral part of the design process, but are implicitly considered through recommended dimensional ranges for different area and terrain types.
- Nominal safety is presumed through the application of the process and technical guidance but safety performance may not be explicitly considered.
- Relies on mathematical models as the basis for derivation of dimensional values (e.g., point-mass model for selection of curve radius and superelevation).

NCHRP Project 15-25, "Alternatives to Design Speed for Selection of Roadway Design Criteria," examined a critical step in the traditional design process. The January 2005 Interim Report for that project points out that "While design speed has always been central to the geometric design process, actual road designs are strongly influenced by design speed in some cases, but not in all cases." That report also notes that "on portions of the highway removed from sight obstructions and horizontal curves, highways designed for a broad range of design speeds may look nearly identical." That project explored alternatives to that portion of the traditional process but lacked the necessary resources and scope to develop a comprehensive solution.

During the past 60 years, transportation needs have changed and much has been learned about the relationships among geometric design, vehicle fleet, human factors, safety, and operations. AASHTO has continually updated its policies to respond to these changes, but such updates have provided limited changes to the fundamental process or basic design approaches. Some agencies have begun using an expanded array of roadway functional classifications as a basis for selecting certain design criteria. An assessment of the current design process is needed to ensure that recent advances in knowledge (e.g., the AASHTO *Highway Safety Manual*) and emerging issues (e.g., complete streets, flexible design) are appropriately addressed.

The objective of this research is to develop a comprehensive, flexible design process to meet the needs of geometric designers in the future. The process considers:

- Specification of the project purpose and need, including the modes that will be using the facility.
- Context setting of the facility.
- Desired performance outcomes for the facility for the various modes; including safety, mobility, and access management.
- Methods for evaluating tradeoffs associated with different design alternatives.
- Optimization of the design given the project's financial and other constraints.
- Flexibility to address issues that arise from stakeholder involvement or environmental reviews.
- Documentation of decisions to address tort liability concerns.



## 2 The Evolution of Highway Design in the US

Highway engineering and design have evolved over the years in response to many factors, events, knowledge gained from both research and ‘trial and error,’ and public policy initiatives. The following is a summary timetable of the evolution of design policy in the U.S.

### 2.1 Up to the 1940s

Through the 1940s the U.S. Highway system was primarily a two-lane rural system. The knowledge base for road design built on that of railroad engineering. Road design was a civil engineering discipline whose sub-discipline skills involved materials properties, structural design, drainage and hydraulics, construction means and methods, and basic physics and mechanics. There was little if any knowledge regarding the operation of vehicles, either individually or in traffic streams. The notion of human factors and the human element as an input to design was understood only in rudimentary terms. Indeed, a prevailing philosophy of highway engineers was that any road properly designed should be able to be driven safely by anyone and everyone.

AASHTO and the U.S. Bureau of Public Roads worked to develop and publish geometric design criteria. Early attempts to develop guidance related to traffic operations by necessity relied on hypothetical, simple rational models of presumed driver/vehicle behavior. The concept of stopping sight distance, for example was based on a simple, rational concept that a driver ought to be able come to a full stop prior to striking an object in the road.

[An interesting sidebar regarding this early work that is not well understood has to do with the dimensions used for the object in the SSD model. Many designers to this day incorrectly believe that the 6-inch object used by AASHTO prior to 2001 had some functional meaning behind it. The very first application of this model to SSD criteria employed a 4-inch object height. That height was selected not because of its dimension, but rather based on a paper study of the cost-effectiveness of constructing alignments to using a range of criteria, from 0 to over 1 ft. The 4-in object was changed to a 6-in object in later years when AASHTO realized that the driver eye height in the vehicle fleet had dropped; but there did not appear to be a need to lengthen the design length of vertical curves. The originators of design policy relied on knowledge of the cost to build a road to make this policy choice, that being the only real knowledge they had.]

An important policy decision at the federal level occurred in 1946. Congress voluntarily waived sovereign immunity. Up until that legislation it was not possible to bring a tort lawsuit against the federal government. State governments followed suit over the next 15 to 20 years. In waiving sovereign immunity a government takes on the responsibility to conduct its business, in the case here, designing and maintaining roads, in a responsible manner.

### 2.2 The 1950s – The Technology of Highway Planning and Design Addresses Burgeoning Mobility Needs and National Public Policy Advances

The 1950s saw rapid economic and population growth in the U.S. Many cities grew significantly. The automobile became the predominant transportation mode. The U.S. vehicle fleet expanded tremendously, and traffic volumes increased on many major arterials.

One of the most significant public policy initiatives in the country’s history was the passage of the 1956 Act establishing a System of Interstate and Defense Highways. This initiative established both a funding stream as well as demand for high-type facilities across the country.

Also in the 1950s the emergence of engineering documents and policy for use by the profession came into being. AASHTO published the first ‘Blue Book’ – A Policy on Geometric Design for Rural Highways – in 1954. In 1950 the



first Highway Capacity Manual was published, providing for the first time a knowledge base and methods for the evaluation of traffic operations. Also in the 1950s the science and technology around travel demand forecasting was invented.

Travel and road-building remained primarily rural, but in the late 1950s and into the next decade saw the beginnings of major freeway and road-building in urban areas.

## 2.3 The 1960s – The Growth of the Interstate System and Urban Transportation

The 1960s saw an unprecedented construction of interstate and other highways across the nation. These roads were for the most part on new alignment, including through major urban areas. Many of the first urban freeway projects had significant effects on cities, and created the first major controversies around roadway infrastructure.

Highway agencies experienced in rural road design applied the same practices and approaches to urban freeways. They were 1) sized to meet theoretical demand and provide high speed service – LOS C—for design year traffic; 2) designed to uniformly very high design speeds; and 3) designed and constructed as engineering infrastructure projects in which non-technical stakeholders (that term did not emerge until decades later) had no role nor input.

The interstate system clearly played a major role in the mobility, quality of life and economic growth of the U.S. Yet its emergence was not without problems. During the 1960's public concern over and interest in the adverse effects of public infrastructure projects (highways being one type) resulted in the first federal legislation around environmental protection.

Other major events in the 1960s included an updated AASHO Blue Book (published in 1965). Most importantly, the highway community in 1963 established the National Cooperative Highway Research Program. Thus began a program by states to jointly prioritize and fund research on important aspects of highway design, operation and construction.

As travel greatly increased, and high speed interstate highways were built and open to traffic, new problems emerged in road design. Traffic fatalities began to climb. By the late 1960s highway deaths exceeded 53,000 annually. The highway death toll spurred congressional hearings which sought to understand the reasons for and causes of the increase in highway deaths. Among the contributing factors highlighted was the significant number of deaths attributed to vehicles running off the road and striking trees, fixed objects, ditches and other roadside appurtenances. For the first time, the highway engineering profession became cognizant of the need to design the roadside to be 'forgiving.' This insight changed the view of road designers and shaped future design policies.

## 2.4 The 1970s – Environmental Initiatives Drive National Transportation Policy and Programs

The 1970s saw the maturation of the interstate system, explosion in traffic, and the onset of developing societal problems and issues associated with construction and operation of the highway system.

The defining major policy initiative of the 1970s was passage of the National Environmental Policy Act. Although NEPA was not aimed only at highway infrastructure, the widespread impacts of road building were clearly a contributor. With NEPA and other regulations and laws that followed, the highway project development process was forever changed. Road design and construction was no longer the purview of engineers and DOTs. The need to meet external stakeholder demands and requirements and address adverse impacts was central to the success of a project and agency program. In 1971 the landmark Overland Park decision by the US Supreme Court codified judicial review over proposed actions of DOTs.

DOTs had to learn how to develop projects to meet the new environmental regulations and laws. This required new skills and processes. It also required a cultural shift – the opening up of the highway engineering field to

others not trained in highway engineering. The entire process became more complex; projects began to take longer to complete, and the costs of highway projects began to increase as the costs of meeting environmental requirements emerged.

Also in the 1970s, states began to experience a large increase in tort liability claims associated with allegations of negligence in their actions in design and maintenance of their systems. The profession struggled with design process and risk management practices, including identifying the need to fully document their design decisions to support defense against tort claims.

By the end of the decade another strong trend emerged – growing congestion in urban areas, often on freeways that were only 10 to 15 years old but operating at volumes above their design capacity. Some early interstate projects constructed in the late 1950s and early 1960s began to show signs of wear and tear, leading to another looming problem – reconstruction of high volume roads under traffic.

In the 1970s AASHTO produced their first design policy written for urban streets and arterials. The 1974 AASHTO Red Book joined the Blue Book as the basis for road design in the U.S.

A final important external event shaped road design and public policy for years to come. The oil embargo and sharp price increases in oil and gasoline that occurred in 1974 changed many things. Public policy shifted to fuel preservation and specifically regulations on fuel economy. Over the next 30 years motor vehicles would become more and more fuel efficient, resulting in a long-term reduction in the funding generated from federal fuel tax revenue.

## 2.5 The 1980s – Transportation Professionals Wrestle with Reconstruction Needs and Congestion as Emerging Issues

The 1980s in many respects represented a watershed in the highway design profession. Urbanization was in full force. DOT programs became more and more focused on urban road problems. Much of the infrastructure constructed in the early 1960s showed need for rehabilitation or reconstruction. DOTs continued to struggle with how to address environmental requirements, both from a process and cost perspective. Growth in fuel tax revenue slowed, and for the first time since the interstate era many agencies found themselves short of the necessary funds to meet program needs.

In response to these trends the 1982 Surface Transportation Act mandated study of 3R projects. FHWA and AASHTO initiated studies of alternative design processes to address the newly recognized problem of infrastructure repair. This effort produced TRB Special Report 214 and eventually policies by FHWA on defining 3R projects and enabling separate design criteria and approaches for these. AASHTO published the first Roadside Design Guide, a significant technical achievement in which science-based knowledge was used and the concept of designing the roadside was established.

The conflict between historic methods for roadway design and practical realities of demand and congestion in urban areas became apparent in more cities. Innovative design solutions – foremost among these being High Occupancy Vehicle (HOV) lanes emerged. In other locations such as the North Central Expressway in Dallas, design decisions were made to purposely limit corridor expansion based on available right-of-way, and include new transit service as part of the overall solution.

FHWA initiated research on the Interactive Highway Safety Design Model (IHSDM) in the late 1980s, beginning a process of integrating operational analysis into design. And AASHTO for the first time published a combined Policy on Geometric Design covering both rural and urban facilities in the same document.

Finally, during the 1980s the incorporation of computer technology in many of the engineering design functions took hold. The profession began a transition from a manual and slide-rule approach to the technical tasks of design, to one more automated.

## 2.6 The 1990s – Unsolved Problems of Congestion, Project Development, Community Sensitivity and Funding Begin to Take Their Toll

DOTs and cities continued to struggle with the costs and impacts of major projects. Boston's Central Artery which began in the 1980s became a symbol to many of both the potential for change but also the complexity and cost of change.

Even though NEPA was over 20 years old, many DOTs still had limited success in efficiently and effectively incorporating environmental and social issues into design development. The ISTEA legislation of 1991 addressed preservation of historic and scenic resources. But legislation was not enough. Perhaps the most significant movement to emerge in over 30 years did so in the early 1990s. Citizen groups, environmental and community activists, and local political leaders across the country became more assertive about their unhappiness with both the process and outcomes of their roadway projects. Context Sensitive Design (which evolved to Context Sensitive Solutions) was promoted as a new approach to transportation projects.

CSD/CSS took on many attributes or directions. Some saw it as a way of addressing the inherently unattractive nature of road infrastructure. Others viewed it as a way to take over the road planning and design decision process from engineers to local authorities and interests. FHWA and then AASHTO directed the discussion of CSS as more process oriented, with some technical advances. FHWA published *Flexibility in Design*. NCHRP Report 480 presented CSS as a guide to best practices or processes. This document for the first time outlined the design dilemma posed by the application of design standards in the context of conflicts with property, environmental features or other community values. CSS was promoted as being a process in which stakeholder interests were obtained in an organized manner; designers were taught to understand flexibility that did exist within AASHTO policies, and the design process as one of making choices and trade-offs was codified.

CSS remains somewhat misunderstood by many. Some DOTs embraced the CSS movement and adapted project delivery methods accordingly. Others gave it lip service or struggled with the philosophy behind it. From the perspective of AASHTO, though, and the history in many places of successful CSS projects, CSS became the expectation of DOT customers and as such has changed design delivery forever.

The other major initiative in the 1990s that interestingly coincided with the CSS movement was a renewed interest and concern over highway fatalities. The AASHTO Strategic Highway Safety Plan, published in 1995 as a collaboration with many national partners, was a fundamental factor in shaping legislation and priorities. What is notable about this effort was that for the first time it represented an institutional awareness and understanding of the complexity of the road safety problem and multi-institutional responsibility for addressing it. The 4 Es – engineering, enforcement, education and emergency medical services, were now understood to all play meaningful roles in both their own actions as well as in coordinating programs with each other. From the mid-1990s through the beginning of the next century, implementation of proven treatments and programs on system-wide bases produced unprecedented reductions in road deaths. In large part because of this interest in safety, the highway engineering community through both AASHTO and FHWA made significant policy decisions in their research focus.

AASHTO made two significant changes to the Green Book in the 1990s. The definition of design speed was changed to reflect continuing concerns over tort liability. Also, the stopping sight distance model was changed based on research from NCHRP Report 400. The object height of 6 inches was revised to 2-ft. This change was the first major design policy change that reduced rather than increased design requirements. Interestingly, many state DOTs were reluctant to embrace this change, choosing to retain the old policy as the basis for their design manuals, despite the fact that it would cost them more. The leadership in such states expressed a concern that they wanted to 'be more conservative' and use the old SSD model.

By the 1990s highway engineering design had become fully automated. The tasks of computing cross sectional and alignment values became much less onerous, less costly, and less prone to engineering error.

## 2.7 The 2000s to the present day – The Need for a New Highway Design Paradigm is Recognized

In the 21st century we have seen the continuation of trends earlier established, and new challenges emerged. The continuation of fuel efficiency placed more severe, permanent limitations on funding for road improvements. Aging infrastructure became the primary problem facing DOTs; the I-35W river bridge collapse was emblematic of the problem, but it was by no means the only example. DOTs also came under considerable pressure to expand their programs to explicitly include pedestrian and bicycle infrastructure.

The severe financial pressures led to innovative approaches, both in project delivery and funding. Regarding the former, the Missouri DOT created the concept of ‘practical design’. The Washington DOT, in response to the needs of funding many major corridor programs and dealing with aging infrastructure on the rural system, fundamentally changed their programming and project design approach with their innovative ‘design matrices.’ Other states followed the lead and have experimented with different project design approaches. During this time design-build as an alternative delivery approach emerged. Among the benefits that states have experienced is the innovation in design and construction that enabled projects to be built at lower costs and in quicker time.

In the view of most DOT leaders, funding limitations to meet program needs have become permanent. Part of the solution to this has been emergence of P3s (public/private partnerships) and tolling. This trend does not directly influence the design process, but it does reinforce the view that DOTs are being expected to produce maximum measurable value for their investments. Indeed, during the 2000s the importance of performance measurement, and asset management to program success is a response to these pressures.

As projects and programs underwent greater scrutiny and the environmental process became more complex, concerns about project delivery time increased during the 2000s. Many major projects took 5 to 10 years or even more from initial planning to construction. Costs increased as well. Environmental streamlining emerged as an important initiative.

Perhaps the most significant long term innovation during the 2000s was the completion of a ten-year effort to develop the first ever Highway Safety Manual. This document is now being implemented by state DOTs. The implications of the HSM with respect to DOT programs and design development in particular are clear. Highway engineers now for the first time have a knowledge base and methodology for developing an objective analysis of the safety performance of their designs.

## 2.8 Recent Advances in Highway Design

### 2.8.1 Introduction

The AASHTO *Green Book (1)* is fundamentally a collection of quantitative geometric design criteria and qualitative design guidance that does not purport to represent any particular design process. The essentially unstated concept in the *Green Book* is that, if a project is designed in accordance with *Green Book* criteria and *Green Book* guidance, the completed project will operate safely and efficiently. Federal policy has institutionalized design criteria as controlling criteria for geometric design as requiring design exceptions if the criteria are not met for new construction or reconstruction projects on National Highway System (NHS) routes and for rehabilitation projects on Interstate freeways. State policies may require design exceptions not only for the controlling criteria identified by FHWA, but for other geometric design criteria, as well.

The current geometric design process, based on the AASHTO *Green Book* and state highway agency design manuals together with the design exception process, or something like it, was likely necessary as a design control in the past, when the operational, and particularly safety, effects of geometric design criteria were poorly

understood. In the past 25 years, there has been an increasing industry movement toward greater flexibility in design to help projects meet the needs of multiple stakeholders. This flexibility has become easier to justify on a project-by-project basis as knowledge about previously unknown traffic operational and safety effects has advanced. Publications that document the need for flexibility, and the extent of flexibility that is achievable in the current design process include the AASHTO *A Guide for Achieving Flexibility in Highway Design* (2) and the FHWA *Flexibility in Highway Design* (3).

As the range of stakeholder views about highway projects and the industry movement toward flexibility have expanded, a number of alternative design concepts have become part of design practice. These alternative concepts include:

- The *complete streets* concept focuses on creating roadways and related infrastructure that provide safe travel for all users.
- The concept of *context sensitive design*, better known as *context sensitive solutions*, places priority on assuring that highway projects fit the context of the area through which they pass, puts project needs as well as the values of the highway agency and community on a level playing field, and considers all trade-offs in decision making.
- The concept of *performance-based design* incorporates a design process that considers explicit consideration of performance measures, typically operational and safety performance measures.
- The concept of *practical design* focuses on addressing only those improvements that are needed and eliminating those improvements that are not absolutely essential, thereby reducing the overall cost of a project.
- The *design matrix approach* includes three levels of design for highway projects: basic, modified, and full design levels.
- The *safe systems approach* takes a holistic approach in that the responsibility for road safety is shared between all facets of the transportation system (i.e., roadway infrastructure, roadway users, and vehicles).
- The concept of *travel time reliability* focuses on designing a roadway in such a way that maximizes the travel time reliability of the roadway.
- The concept of *value engineering* is a systematic process of project review and analysis by a multi-disciplinary team to provide recommendations for improving the value and quality of the project.
- The concept of *Designing for Resurfacing, Restoration and Rehabilitation Projects* includes a set of geometric design criteria for 3R projects that are less restrictive than the geometric design criteria in use for new construction and reconstruction.
- The concept of *Designing for Very Low-Volume Local Roads ( $\leq 400$  ADT)* recognizes that very low-volume local roads represent a different design environment than higher-volume roads.

All of these concepts profess to consider a broad range of design issues, but each concept has been advocated by interest groups or adopted by highway agencies with specific priorities in mind. The advocates of each of these alternative concepts recognize the need to consider competing viewpoints in the design of a project, and likely consider themselves to be seeking project designs that consider and balance all competing stakeholder goals and interests, but their choice of the alternative concept they advocate often tells something about the factors to which they assign a high priority.

The stated goal of the complete streets concept is to consider all transportation modes in the design of urban and suburban arterials; most advocates of complete streets emphasize explicit consideration of bicycle and pedestrian needs. The stated goal of context sensitive solutions is to assure that each project is designed in a manner consistent with the context of the roadway; most advocates of context sensitive design advocate strong consideration of community, neighborhood, and/or environmental values. The stated goal of performance-based design is to explicitly consider operation and safety performance measures in the design process and, potentially, to design to achieve specific operation and/or safety goals for each project. The stated goal of practical design is, where appropriate, to relax specific design criteria to minimize project costs, consistent with achieving other

stated goals; most advocates of practical design seek to take maximum advantage of design flexibility in reducing costs. The stated goal of the safe systems approach is to design each project so that motorists will choose to travel at speeds that the designers consider appropriate to the crash risks present on the roadway; advocates of the safe systems approach typically assign a high priority to the consideration of safety performance measures. The goal of travel time reliability is to make travel time more consistent, and thus reduce day-to-day variations in travel times on a given section of road; advocates of travel time reliability are typically seeking designs that can reduce the potential impact of nonrecurrent congestion on travel times. Value engineering seeks to improve the value of designs, by modifying any aspect of the design that would result in an increase in value; advocates of value engineering have similar goals to advocates of practical design, but potentially seek not only the same (or better) project performance at lower cost, but also better project performance, even at somewhat higher cost.

Highway agency criteria for design of resurfacing, restoration, and rehabilitation (3R) projects on nonfreeway facilities and the AASHTO *Geometric Design Guidelines for Very Low-Volume Local Roads (ADT $\leq$ 400)* (4) are both examples of practical design and the application of design flexibility, based on risk assessment, that seeks to achieve equal (or, at least, acceptable) performance to that achieved by full AASHTO *Green Book* design criteria at lower cost.

All of the alternative concepts have useful features that should be considered in developing a revised geometric design process. Yet, none of these concepts is, by itself, a complete and sufficient process for identifying and considering all factors relevant to design decisions. Each of these alternative concepts is reviewed below with the intention of identifying features of each concept that can and should become part of a revised geometric design process.

### 2.8.1.1 Complete Streets Concept

For years, the objective of designing a roadway was to move as many vehicles (and without emphasis on all road users including pedestrians, bicyclists) as possible, as efficiently as possible, from Point A to Point B. This was the objective whether one was designing a freeway or a city street. Today, however, the objective of designing a roadway – particularly one with multiple user types – has shifted toward providing for the safe mobility of all travelers, not just motor vehicles. This concept has become referred to as “complete streets.” According to the National Complete Streets Coalition, complete streets are designed to enable pedestrians, bicyclists, motorists, transit users, and travelers of all ages and abilities to move along the street safely.

Although the guiding principle for complete streets is to create roadways and related infrastructure that provide safe travel for all users, each complete street has to be customized to the characteristics of the area the street serves. Traffic calming techniques are sometimes used to encourage lower speeds to increase safety. A complete street also has to accommodate the needs and expectations of the travelers who want to access or pass through the surrounding neighborhood, community, or region.

According to the National Complete Streets Coalition, typical elements that make up a complete street include:

- Sidewalks
- Bicycle lanes (or wide, paved shoulders)
- Shared-use paths
- Designated bus lanes
- Safe and accessible transit stops
- Frequent and safe crossings for pedestrians, including median islands, accessible pedestrian signals, and curb extensions

Certainly, a design for a complete street in a rural area will look quite different from one in an urban or suburban area. For example, a complete street in a rural area could involve providing wide shoulders or a separate multiuse path instead of sidewalks. The common denominator, however, is balancing safety and convenience for everyone using the road.

### 2.8.1.2 Context Sensitive Solutions

The concept of context sensitive solutions (CSS) has been evolving in the transportation industry since the National Environmental Policy Act of 1969 required transportation agencies to consider the possible adverse effects of transportation projects on the environment. The CSS concept gained significant momentum in 1998 when the AASHTO and FHWA jointly sponsored the “Thinking Beyond the Pavement” national conference, which generated the first working definition of context sensitive design (CSD). Since that conference, context sensitive design has evolved into context sensitive solutions, which is defined as:

Context sensitive solutions (CSS) is a collaborative, interdisciplinary approach that involves all stakeholders in providing a transportation facility that fits its setting. It is an approach that leads to preserving and enhancing scenic, aesthetic, historic, community, and environmental resources, while improving or maintaining safety, mobility, and infrastructure conditions. (5)

- Results of Joint AASHTO / FHWA Context Sensitive Solutions Strategic Planning Process, Summary Report, March 2007

The context sensitive solutions concept places priority on assuring that highway projects fit the context of the area through which they pass, particularly with respect to neighborhood, community, and environmental concerns. A context sensitive solutions approach puts project needs as well as the values of the highway agency and community on a level playing field and considers all trade-offs in decision making.

A Context Sensitive Solutions approach is guided by four core principles:

- Strive towards a shared stakeholder vision to provide a basis for decisions.
- Demonstrate a comprehensive understanding of contexts.
- Foster continuing communication and collaboration to achieve consensus.
- Exercise flexibility and creativity to shape effective transportation solutions, while preserving and enhancing community and natural environments.

*A Guide to Best Practices for Achieving Context Sensitive Solutions* was developed by Neuman et al. (6) in NCHRP Report 480. The guide demonstrates how transportation agencies can incorporate context sensitivity into their transportation project development work. The guide is applicable to a wide variety of projects that transportation agencies routinely encounter. One of the key strengths of a context sensitive solutions approach is its applicability to all of the roles found within a transportation agency, including project managers, highway engineers, environmental specialists, public involvement specialists, senior managers, and transportation agency administrators. While each role brings a different point of view to the table, all of the roles are critical to the success of transportation improvements. The guide in NCHRP Report 480 was designed to reflect each of these different perspectives.

### 2.8.1.3 Performance-Based Design

Performance-based design incorporates a design process that considers explicit consideration of performance measures, typically operational and safety performance measures. In performance-based design, each design decision should be explicitly assessed in terms of its potential impact on operations and safety. NCHRP Report 785 *Performance-Based Analysis of Geometric Design of Highways and Streets* provides a principles-focused approach that looks at the outcomes of design decisions as the primary measure of design effectiveness.

Performance-based design is consistent with the *Highway Safety Manual* (HSM) (7) goal of moving away from design for nominal safety (i.e., meeting specific geometric design criteria) toward substantive safety (i.e., meeting explicit performance criteria). Carried to its logical conclusion, performance-based design could have the goal of meeting specific operational and safety targets established by the highway agency for each project. Since the development of the level-of-service concept in the 1965 *Highway Capacity Manual* (HCM) (8), geometric design has always been performance-based with respect to operations. Only with the publication of the first edition of the HSM in 2010 has it been possible for geometric design to be truly performance-based with respect to safety

for at least some design criteria. As new capabilities are added to the HSM over time, it will become increasingly possible for design of all geometric criteria for all project types to be performance-based.

The HCM (8) serves as a traffic operational performance evaluation tool for performance-based design. The most common traffic operational performance measure is the level of service determined with HCM procedures. Levels of service, represented by levels A (uncongested) through F (oversaturated), are based on different performance measures (known in the HCM as service measures) for each facility type. The performance measures used as service measures in the current HCM are shown in Table 1.

Table 1. Performance Measures Used to Determine Level of Service in the HCM

Facility Type	HCM Chapter	Performance Measure(s) Used as the HCM Service Measure
Rural Two-lane Highways	15	Percent time spent following average travel speed
Rural Multilane and Suburban Highways	14	Traffic density
Urban Streets	16-17	Average Travel Speed
Freeways	10-13	Traffic density
Signalized Intersections	18	Delay
Unsignalized Intersection	19-21	Delay

Highway agencies generally set level-of-service targets for each project. Table 2, based on *Green Book* Table 2-5, suggests specific level-of-service targets for projects by functional class and terrain. However, highway agencies can adjust these targets for all projects or for specific projects within their jurisdiction. FHWA has recently published a memorandum clarifying that there are no regulations or policies that require minimum LOS values for projects on the National Highway System, <http://www.fhwa.dot.gov/design/standards/160506.cfm>

Table 2. Guidelines for Selection of Design Levels of Service in the Green Book

Functional Class	Appropriate Level of Service for Specified Combinations of Area and Terrain Type			
	Rural Level	Rural Rolling	Rural Mountainous	Urban and Suburban
<b>Freeway</b>	<b>B</b>	<b>B</b>	<b>C</b>	<b>C or D</b>
<b>Arterial</b>	<b>B</b>	<b>B</b>	<b>C</b>	<b>C or D</b>
<b>Collector</b>	<b>C</b>	<b>C</b>	<b>D</b>	<b>D</b>
<b>Local</b>	<b>D</b>	<b>D</b>	<b>D</b>	<b>D</b>

The publication of the first edition of the HSM (7) in 2010 gave highway agencies for the first time a broadly based tool for performance-based safety analysis. The HSM Part C procedures can be used to estimate the expected long-term crash frequencies and crash severity/crash type distributions for a range of project types. HSM Part C provides crash prediction models for rural two-lane highways, rural multilane highways, and urban and suburban arterials. The results of NCHRP Project 17-45 have added crash prediction models for freeways, interchange ramps, and ramp terminals. HSM procedures are provided to combine crash predictions from the HSM Part C models with observed crash history data to obtain the best available estimate of long-term crash frequency for a particular roadway segment or intersection. The current HSM procedures are reasonably comprehensive (see the list in Table 3 of geometric design elements currently included), but do not necessarily address every geometric design element of potential interest to designers. Research is continuing and more geometric design elements will likely be added to the HSM procedures over time.



Table 3. Geometric Design Elements in Current HSM Chapters

---

<b>Lane width</b>
<b>Shoulder width</b>
<b>Horizontal curve length</b>
<b>Horizontal curve radius</b>
<b>Superelevation and presence or absence of spiral transitions</b>
<b>Grades</b>
<b>Driveway density</b>
<b>Passing lanes</b>
<b>Two-way left-turn lanes</b>
<b>Intersection skew angle</b>
<b>Median width</b>
<b>Right-turn lane</b>
<b>Left-turn lane</b>

---

The HSM models have the following general form, which incorporates safety performance functions (SPFs), crash modification factors (CMFs), and calibration factors:

$$N_{\text{predicted}} = N_{\text{spf}x} \times (\text{CMF}_{1x} \times \text{CMF}_{2x} \times \dots \times \text{CMF}_{yx}) \times C_x$$

Where:

$N_{\text{predicted}}$  = Predicted average crash frequency for a specific year for site type  $x$ ;

$N_{\text{spf}x}$  = Predicted average crash frequency determined for base conditions of the SPF developed for site type  $x$ ;

$\text{CMF}_{1x}$  = Crash modification factors specific to site type  $x$  and specific geometric design and traffic control features  $y$ ; and

$C_x$  = Calibration factor to adjust SPF for local conditions for site type  $x$ .

The CMFs used in the crash prediction models take a variety of forms. As an example, the following equations (Table 4), illustrated in Figure 1, show how the value of the CMF for lane width on rural two-lane highways is determined:

Table 4. CMF for Lane Width on Roadway Segments (CMF<sub>ra</sub>).

Lane Width	AADT (vehicles per day)		
	<400	400 to 2000	>2000
9 ft or less	1.05	$1.05 + 2.81 \times 10^{-4}(\text{AADT}-400)$	1.50
10 ft	1.02	$1.02 + 1.75 \times 10^{-4}(\text{AADT}-400)$	1.30
11 ft	1.01	$1.01 + 2.5 \times 10^{-5}(\text{AADT}-400)$	1.05
12 ft or more	1.00	1.00	1.00

Note: The collision types related to lane width to which this CMF applies include single-vehicle run-off-the-road and multiple-vehicle head-on, opposite-direction sideswipe, and same-direction sideswipe crashes.

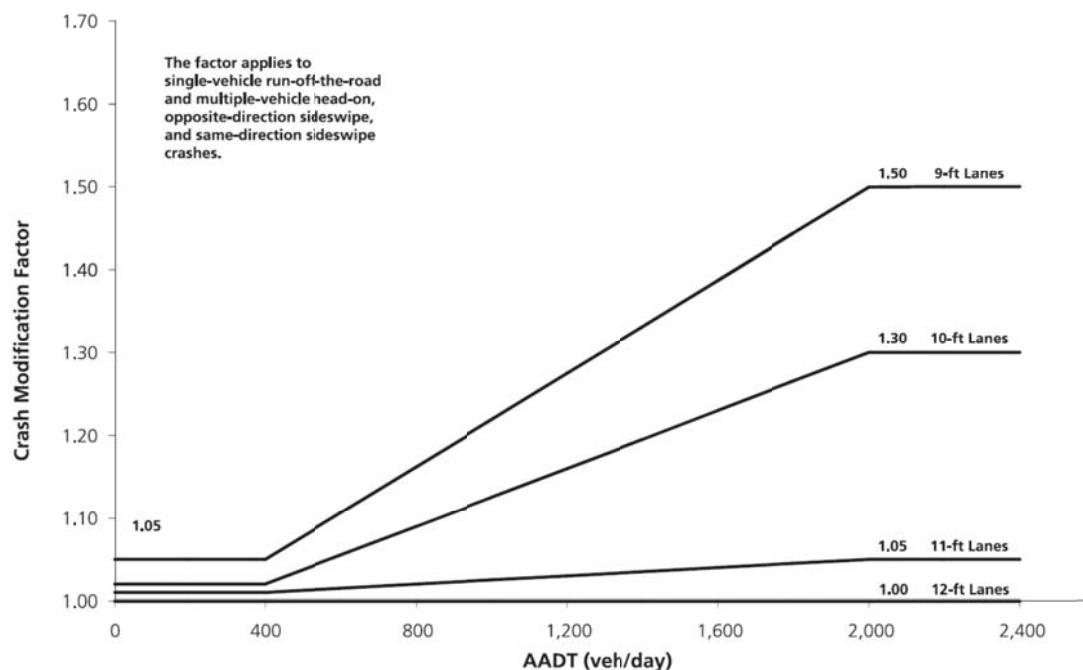

Figure 1. Crash Modification Factor for Lane Width on Roadway Segments

A performance-based design process involves, at a minimum, estimating the operational and safety effects of each design decision for which it is feasible to make such estimates with available tools and to consider those operational and safety estimates explicitly in making geometric design decisions. Typically, many factors other than operations and safety are considered in geometric design decisions, so operations and safety will not necessarily be the deciding factors for all geometric design decisions in all projects, but clearly designers recognize operations and safety as important decision factors.

A performance-based design process, with goals based on both operational and safety targets, is now feasible for many projects. The current state of practice already includes a performance-based design process with goals based on traffic operational (i.e., level of service) targets. A performance-based design process with goals based on safety targets (i.e., specific crash frequencies either for expected total crashes or expected crashes by severity level) is now feasible, although it does not appear that such a process has yet been adopted. One disadvantage of such a process is that highway agencies might be reluctant to specify explicit crash frequency targets for a project, lets the agency leave themselves open to tort liability actions for crashes that occur at a project site where actual crash experience exceeds the target levels; in such a case, plaintiffs might argue that the design selected by the highway agency was inappropriate since the target crash frequency was exceeded. A more workable alternative might involve establishing design categories for projects, where the description of each design category might include a range of expected rash frequencies.

#### 2.8.1.4 Practical Design

The concept of “practical design” focuses on doing everything well instead of a few things perfectly. The concept was first developed within the Missouri Department of Transportation (MoDOT) amidst serious funding shortfalls and rising construction costs. MoDOT's senior management decided that, while the negative economic conditions were completely beyond MoDOT's control, they were not willing to deliver anything less to the public than they had promised.

As part of MoDOT's Practical Design process, they critically review projects to establish reduced-cost scope and road geometry based on needs and not standards. That is, those improvements that are really needed are included in projects, and those improvements that could be considered unnecessary are eliminated. In essence, MoDOT's Practical Design process aims toward "fewer spots of perfection and more good projects that make a great system" (9). In its implementation guide, *Practical Design, Meeting Our Customer's Needs* (10), MoDOT provides primary design guidance for 29 areas including type of facility, geometric design elements, pavements, structures, roadside safety, and miscellaneous. The guidelines provided in that document allow for flexibility in the selection of the specific design value.

MoDOT is not the only state department of transportation faced with many demands—such as maintenance, expanding infrastructure, and improving safety—and having to meet these demands with limited financial resources. In an attempt to deliver a highway system that meets the needs of taxpayers yet still fits within a very limited budget, several highway agencies have adopted the concept of "practical design".

The Kentucky Transportation Cabinet (KYTC) has approached this program from a somewhat different perspective through their Practical Solutions initiative, where the philosophy of building reduced-cost projects is emphasized using the existing condition as the baseline design and thus achieving a positive outcome with project improvements beyond the existing conditions.

In addition to Missouri and Kentucky, four other states have adopted Practical Design policies and procedures. These include Idaho, Kansas, Oregon, and Utah.

#### 2.8.1.5 The Design Matrix Approach

The Washington Department of Transportation (WSDOT) developed its own way of implementing "practical design." WSDOT established three levels of design for highway projects: basic, modified, and full design levels – known as a *design matrix*. The design matrices were used to identify the design level, as defined below, for a project and the associated processes for allowing design variances:

- Basic Design Level – preserves pavement structures, extends pavement service life, and maintains safety highway operations.
- Modified Design Level – preserves and improves existing road geometry, safety, and operational elements.
- Full Design Level – improves road geometry, safety, and operational elements.

The design matrices addressed the majority of Preservation and Improvement projects and focus on those design elements that are of greatest concern in project development.

#### 2.8.1.6 The Safe System Approach

Australia and New Zealand, as well as much of the European Union, have adopted the Safe System approach to road safety improvement. The Safe System approach takes a holistic approach in that the responsibility for road safety is shared between all facets of the transportation system (i.e., roadway infrastructure, roadway users, and vehicles).

The elements of this approach are:

- Safe roads and roadsides – roads that provide an environment for road users to make informed and timely decisions on the paths of travel, preventing crashes from happening where possible, encouraging appropriate travel speeds and that are forgiving, not penalizing a road user if they make a mistake, with death or serious injury.
- Safe speeds – setting speeds that are consistent with the functional classification of the road and appropriate for the road environment and road users' circumstances such that a person should survive the most likely type of crash should one occur.
- Safer vehicles – vehicles that protect occupants and road users should a crash occur.
- Road users who are being alert and compliant.

Under a Safe System, crashes should be prevented from happening where possible. Where not possible, the travel speed should be such that a person should survive the most likely type of crash to occur. The speeds, above which the chances of surviving a crash substantially decrease are currently:

- 70 km/h (45 mph) for head-on crashes
- 50 km/h (30 mph) for sideswipe crashes
- 40 km/h (25 mph) for fixed-object crashes
- 30 km/h (20 mph) for crashes involving a pedestrian or bicyclist

### 2.8.1.7 Travel Time Reliability

As noted in the discussion of performance-based design in Section 2.8.4, the accepted measure of traffic operational performance for highway projects is the level of service which, in turn, is derived from specific operational performance measures for specific facility types, as indicated in Table 1. In recent years, highway agencies have begun to consider an alternative method of characterizing the traffic operational performance of highway facilities based not only on their level of service, but also on how consistently that level of service is provided from hour-to-hour and day-to-day over a period of a year or more. That consistency in meeting traffic operational expectations is referred to as travel time reliability.

Travel time is influenced by recurrent congestion, which occurs in hourly traffic patterns that typically repeat themselves from day to day. Travel time reliability is strongly influenced by nonrecurrent congestion which results in traffic delays from factors other than the typical hourly traffic patterns. Key sources of nonrecurrent congestion include:

- Traffic incidents
- Special events
- Work zones
- Traffic control devices
- Demand fluctuations
- Weather

The concept of travel time reliability has been most extensively developed in the Strategic Highway Research Program 2 (SHRP 2) reliability research effort. Specifically, SHRP 2 Project L07, *Identification and Evaluation of Design Treatments to Reduce Nonrecurrent Congestion*, developed a tool to assist highway agencies in selecting geometric design treatments to reduce nonrecurrent congestion and, therefore, increase travel time reliability (11). (<http://www.trb.org/main/blurbs/170653.aspx>) This Project L07 tool could enable consideration of travel time reliability to become a routine part of the geometric design process.

SHRP 2 Project L07 has documented that traffic congestion has effects on safety as well as traffic operations. Figure 2 illustrates the typical variation of crash frequency, by crash severity level, with traffic operational level of service. The figure illustrates that crash frequencies increase with congestion over the congestion range from Level of Service C to Level of Service F. This implies, conversely, that safety can be improved by improving traffic operations in the range from Level of Service F to Level of Service C.

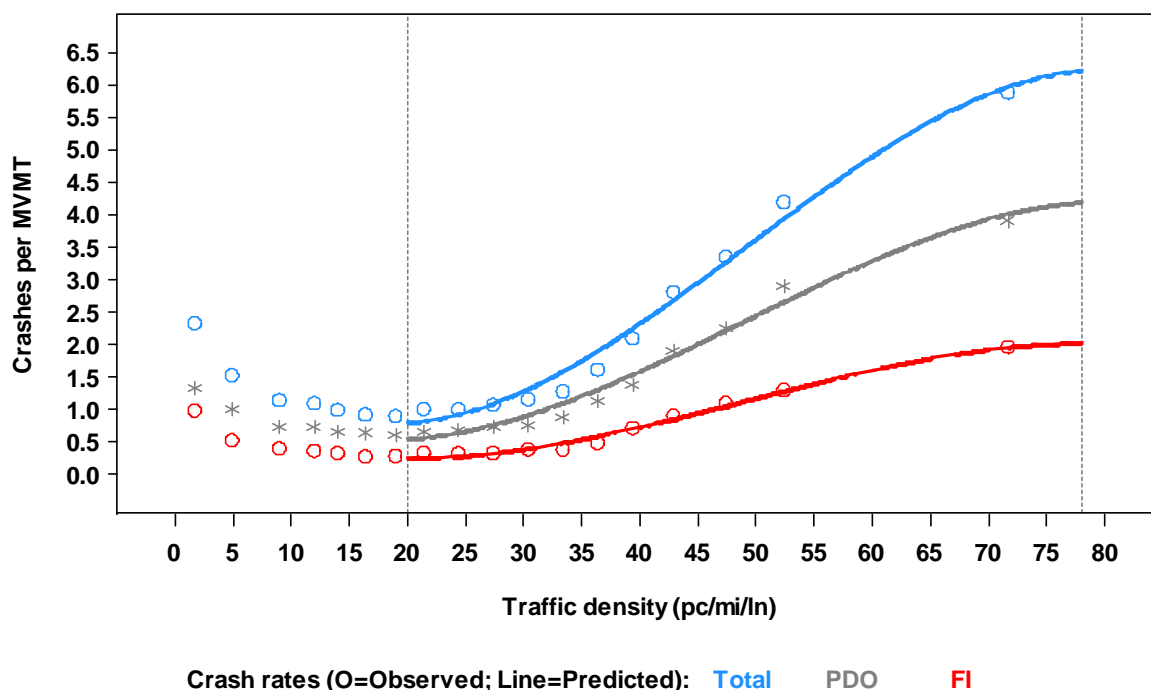

Figure 2. Typical Observed and Predicted Total, FI, and PDO Crash Rates vs. Traffic Density (ref to L07 report)

### 2.8.1.8 The Value Engineering Concept

Value engineering is typically implemented in geometric design once the project design is nearly complete and ready for a design review. A value engineering review is typically performed by engineers other than those who designed the project and their role is to look for opportunities to increase the project's value. Value can be defined in terms of any performance measure for the design, including project cost. Value engineering seeks to identify changes to the initial design that will either provide the same (or better) performance at less cost, will provide better performance for the same cost, or will, in some cases, provide better performance for additional cost.

In its application to highway projects, and highway design in particular, Value engineering has often translated to a revisiting of design standards or criteria applied to a project. VE practitioners question assumptions behind the design standards as being relevant or appropriate given their impacts on project costs; and given the too-frequent inability to link the design standard dimensions to measures of value such as travel time, delay, or crash cost savings.

Given this approach, value engineering can be seen as a variation of performance-based design and practical design. Value engineering is, by definition, performance-based, because the value of a project cannot be assessed without one or more performance measures. The performance measures can represent safety, traffic operations, project cost, or any other attribute that stakeholders value.

### 2.8.1.9 Design of Resurfacing, Restoration and Rehabilitation Projects

Since the 1980s, fewer new roads have been built, thus shifting the emphasis of highway agencies to reconstructing or rehabilitating the highway system we have. The aging of our highway system, together with fiscal constraints, are placing increased pressures on highway agencies to maintain the highway system in a cost-effective manner and are, thus, creating greater needs for 3R projects.

Geometric design criteria have historically been established by AASHTO policies, which apply not only to new construction projects but also to reconstruction projects. In 1977, AASHTO (12) proposed a set of geometric

design criteria for 3R projects (the “purple pamphlet”) that were less restrictive than the geometric design criteria in use for new construction and reconstruction. This proposal began a storm of criticism from safety advocates who wanted all 3R projects brought up to full new construction criteria in the name of safety. One of the controversies was whether resurfacing of 3R projects without accompanying geometric improvements resulted in speed increases that, in turn, increased crash rates. Congress held hearings on this issue in 1981 and, as a result, the Surface Transportation Assistance Act of 1982 mandated a study of the cost-effectiveness of geometric design standards and the development of minimum standards for 3R projects on roads other than freeways.

The result of this Congressional mandate was a formation of study committee and the publication in 1987 of TRB Special Report 214, *Designing Safer Roads: Practices for Resurfacing, Restoration, and Rehabilitation* (13). Special Report 214 proposed geometric criteria for 3R projects that have become widely accepted. TRB Special Report 214 was accompanied by TRB State of the Art Report 6 (14), which presented seven resource papers that documented the then-current state of knowledge on lane width, shoulder width, and shoulder type (15); bridge width (16); pavement edge drop-offs (17); roadway alignment (18); sight distance (19); pavement resurfacing (20); and the potential impact of future changes in the vehicle fleet (21).

There have been many changes in both the state of knowledge and highway agency policies since the publication of TRB Special Report 214 in 1987. These include:

- Five updates to the AASHTO *Green Book* (in 1990, 1994, 2001, 2004, and 2011)
- Establishment of agreements between FHWA and a number of state highway agencies on 3R design policies
- Publication of the AASHTO *Guidelines on Geometric Design of Very Low Volume Local Roads ( $\leq 400$  ADT)* (4) in 2001
- Research on the effect of pavement resurfacing on traffic speed in NCHRP Report 486 in 2003 (14)
- Completion of the Resurfacing Safety Resource Allocation Program (RSRAP) in NCHRP Report 486 in 2003 (22)
- Publication of the latest safety knowledge in the first edition AASHTO *Highway Safety Manual* (HSM) (7) in 2010
- Completion of additional safety research leading toward a second edition of the HSM
- Updates of the TRB Highway Capacity Manual (8) in 2000 and 2010

Research in NCHRP Project 15-50 is developing an update to the 3R design guidelines in TRB Special Report 214, which was written 25 year ago. It appears that, to meet the current needs of highway agencies, the updated guidelines should not simply address geometric design criteria, but should provide a cost-effectiveness analysis approach to assist agencies with geometric design decisions, together with tools to implement that approach. Such a cost-effectiveness tool could potentially be created by updating the spreadsheet-based RSRAP tool from NCHRP Report 486 (14), developed nearly 10 years ago.

#### 2.8.1.10 The AASHTO Guide for Geometric Design of Very Low-Volume Local Roads ( $ADT \leq 400$ )

AASHTO published the *Geometric Design Guidelines for Very Low-Volume Local Roads ( $\leq 400$  ADT)* (4), referred to here as the VLVLRL guidelines, in 2001. These guidelines were written as part of NCHRP Project 20-7(108), based on risk assessment research performed in NCHRP Project 20-7(75). The guidelines were developed in recognition that very low-volume local roads represent a different design environment than higher-volume roads, which are generally designed in accordance with the AASHTO *Green Book*. (2, 3, 4). Such roads represent a significant portion of many agencies’ road networks, and their construction and maintenance can require major portions of their operating budgets. The design environment for very low-volume local roads is distinct in that the lower average daily traffic design volumes (400 veh/day or less) translate to a much lower risk profile than other roads with higher traffic volumes. In addition, local roads (except those in recreational areas) by definition serve a driver population primarily made up of repeat drivers who are familiar with the roads. The guidelines also address very low-volume local roads with other driver populations, including recreational roads (which are more likely to serve unfamiliar drivers) and resource recovery roads (such as roads under the jurisdiction of the U.S. Forest Service) used primarily by professional drivers in larger design vehicles. Finally, the current VLVLRL guidelines state that the

guidelines may be applied not only to very low-volume local roads, but also to very low-volume roads functionally classified as collectors, if they serve traffic volumes of 400 vehicles per day or less and serve a driver population that consists primarily of drivers familiar with the road in question.

With the above in mind, development of the AASHTO VLVLRL guidelines presented geometric design criteria for many specific design elements, applicable to new construction or reconstruction projects that are less restrictive, and thus less costly to implement, than the design criteria applicable to higher volume roads, as presented in the *Green Book*. These less restrictive design criteria were justified through a risk assessment conducted in NCHRP Project 20-7(75), which reflected the very low crash frequency risk expected on very low-volume roads (5). Furthermore, the guidelines introduced the concept that geometric design changes to existing very low-volume local roads may be essential only where documented crash patterns indicate a safety performance benefit associated with such changes. Where no crash pattern associated with a specific geometric feature or element exists, the guidelines enable highway agencies to leave the road geometry unchanged when undergoing infrastructure-related reconstruction. This flexibility in the guidelines allows agencies to avoid investing limited highway funds in geometric design changes intended to improve safety unless there is evidence of a likely documentable safety benefit from the improvement. As traffic volume is the most basic and strongest indicator of crash risk, benefits from geometric improvements are much more likely achievable on higher volume roads than on very low-volume roads. Thus, the design guidelines for existing very low-volume local roads provide great flexibility to highway agencies and introduce a strong sense of “*if it ain’t broke, don’t fix it,*” with crash history data guiding decisions as to whether geometric design changes should be considered.

Both the research philosophy and the adoption of the VLVLRL guidelines represent the first major change in highway design criteria to be more ‘context sensitive’ and directly responsive to principles of cost-effectiveness as determined by the relationship of traffic volume to transportation value.

#### 2.8.1.11 Summary of Alternative Concepts for Consideration

There has been an increasing movement toward greater flexibility in design to help transportation projects meet the needs of multiple stakeholders. As the range of stakeholder views about highway projects and the industry movement toward flexibility have expanded, a number of alternative design concepts have become part of design practice. These alternative concepts include:

- The *complete streets* concept
- The concept of *context sensitive solutions*
- The concept of *performance-based design*
- The concept of *practical design*
- The *design matrix approach*
- The *safe systems approach*
- The concept of *travel time reliability*
- The concept of *value engineering*
- The concept of *Designing for Resurfacing, Restoration and Rehabilitation Projects*
- The concept of *Designing for Very Low-Volume Local Roads ( $\leq 400$  ADT)*

Each of these alternative concepts has useful features that should be considered in developing a revised geometric design process. Yet, none of these concepts is, by itself, a complete and sufficient process for identifying and considering all factors relevant to design decisions. In total though, these alternative concepts reveal the following are important lessons to a revised geometric design process:

- Roads serve more than just motor vehicles
- Road design involves many different disciplines
- Context matters and it varies
- Performance (operational, safety) is important
- Performance may have many dimensions
- Safety performance should focus on elimination or mitigation of severe crashes

- Speed and crash severity are closely linked
- Existing roads with known problems are different from new roads
- Traditional design approaches (full application of AASHTO criteria) are believed by professionals to yield suboptimal results
- Focusing on identifying and addressing the problem(s) should be central to developing design solutions
- Safety risk and cost-effectiveness are related to traffic volume

These lessons are also common among multiple alternative concepts. Table 5 presents a matrix that demonstrates how the various concepts emphasize each of these lessons.

The design matrix approach developed by WSDOT appears to hold promise as a new framework for *organizing* geometric design.

Table 5. Overlap of Alternative Design Concepts

Important Insights for the Geometric Design Process	Alternative Design Processes and Initiatives										
	Complete Streets	Context Sensitive Design	Performance-Based Design	Practical Design	Design Matrix	Safe Systems	Travel Time Reliability	Value Engineering	Designing for 3R	Designing for VLVR	Systemic Safety
Roads serve more than just motor vehicles	●	●									
Road design involves many different disciplines	●	●	●			●		●	○		
Context matters and it varies	●	●	○	○	●	○	○	○		●	●
Performance (operational, safety) is important		○	●	●	●	●	●	○			●
Performance may have many dimensions	●	●	●	●	●		●	○	○		
Safety performance should focus on elimination or mitigation of severe crashes			○	○	○	●		○		○	●
Speed and crash severity are closely linked			●			●					
Existing roads with known problems are different from new roads				●	●				●	○	●
Traditional design approaches (full application of AASHTO criteria) are believed by professionals to yield suboptimal results	●	●		●	●			○			○
Focusing on identifying and addressing the problem(s) should be central to developing design solutions	○	○	●	●	●		○	●	○		●
Safety risk and cost-effectiveness are related to traffic volumes			●		●				○	●	●
● Fully applies ○ Partially applies											



## 2.8.2 History and Evolution of the Highway Industry

Much has changed from the 1940s to the present. Although the highway system is still predominantly rural, the majority of trip-making occurs in urban areas. From the 1950s up until the 1970s, the task of planning, design and construction of roads was a highway engineering problem that DOTs undertook with little outside involvement. Resources were sufficient, with strong public support for road construction. The combination of environmental sensitivities, greater public interest in infrastructure, urbanization of the industry, all produced changes in the types of projects and approaches to design.

Throughout the past 60 years DOTs and the AASHTO community have invested in research and adapted in many ways to these changes; but in many ways change has not occurred to the extent needed. The mindset of designers and design processes continues to be ‘rural-oriented’ and is not sufficiently adapted to the unique, multimodal urban environment. Such a mindset is often characterized by the mantra ‘more is better.’ In an era and context in which funds are adequate, additional right-of-way readily available, and adverse consequences de minimis, this mindset has been considered the appropriate, conservative approach to highway design. This design process, originally developed when most road design projects were new rural alignments on newly acquired right-of-way, has been slow to acknowledge these important fundamental differences:

- In many areas, and for many agencies, new roads are a tiny or negligible part of their overall program. The vast majority of projects are reconstruction of existing roads on existing right-of-way, which are unique in their design challenges.
- There is considerable growth in knowledge over the past 20 years on the safety and operational effects of road design dimensions and variables; much more and deeper knowledge than existed when the original design policies were written and updated. Such knowledge grows every year and enhances our understanding of what impacts our design decisions can have.
- Design criteria for the most part are fundamentally unchanged in their basic forms from the early days of their development. Despite recent research and some revisions to design policy, the basic models underpinning much of highway engineering remain overly simplistic, insensitive to the full range of context, and lacking in direct relationship to the knowledge base on highway crashes as well as operations. Of specific importance are models used to determine sight distance, and to establish controls for horizontal alignment.
- Highway design professionals continue to be taught to focus on application of design standards and to believe in the ‘standards equal safety’ mental model. Nuances in performance associated with marginal changes in design dimensions are not part of the normal design process. Knowledge about safety and operational effects is not readily applied as routine practice in design. As a result, much of highway engineering design has become ‘defensive’ in nature, with focus on processes intended to protect agencies from tort liability actions.
- Agencies and agency staff remain organized and function in knowledge silos. The role of highway engineers is to produce a three-dimensional design suitable for bidding and construction. The foundational issues of how the road as designed will operate are too –often left to other professionals (traffic engineers, highway safety specialists) whose input may be ‘after-the-fact,’ or tangential to the tasks the highway engineer

Clearly, the world in which agencies and their staff work has changed considerably since the 1950s. The need for fundamentally different approaches to highway design, viewed from a distance and with the perspective of history, seems self-evident. Following are some items of general concerns and discussions in justification for a need of changes to the current state of practice.

- Much of the content of the AASHTO Green Book has either remained unchanged, or not been fundamentally questioned despite both research and anecdotal evidence. Design standards and the basic

design models continue to be considered appropriate unless and until proven otherwise. Contents of the AASHTO Policy that were products of unproven hypotheses in their original formulation remain in place in the Policy, unquestioned after many years. Indeed, in some cases lack of documentation and institutional memory is such that the presence of one or more criteria leaves open the question of what its purpose or value is. There remain many criteria that were developed to address the practical issues associated with hand calculations, a need that is long gone.

- The direct input of what may be referred to as ‘external’ influences such as environmental effects remains outside the direct application of design criteria to the design process. Highway design processes still rely on a process that labels environmentally sensitive solutions as ‘design exceptions’ rather than as context-appropriate solutions.
- The significant variation in context – rural vs. urban, geography, presence of non-motorized road users is inadequately incorporated in current processes. A significant aspect of context is the basic project type of new vs. reconstructed or rehabilitated roads. These clearly differ.
- Process solutions such as Value Engineering and CSS, although well intentioned and valuable, have become ‘add-ons’ to the overall design process, adding to both the cost and time to complete an assignment. Moreover, such process solutions in repeatedly producing challenges to fundamental design standards or assumptions, raise uncertainty and frustration for highway design professionals who have been taught to follow and not question the design standards.

Perhaps most importantly, the size and age of the highway system and the apparent limitations in funding its maintenance have yet to be reflected in both the technical and process aspects of highway design. The mental model of a ‘conservative’ designer to upgrade a road to current standards is no longer the right approach. Indeed, the design standards themselves, which are the building blocks of design, should undergo a thorough review. In the current and future environment, the AASHTO community must recognize the need for the highway design process to be as fully performance-based as possible.

Finally, technology and the vastly expanded knowledge base of safety and operations, on human factors and vehicle performance offers opportunities; indeed demands that the profession make best use of such technology. Highway engineers can be freed-up from the now mundane tasks of alignment calculation, and instead focus on incorporating as part of the design process the many and varied inputs and outputs that may be result from a given set of alternative solutions.

### 2.8.2.1 References

1. American Association of State Highway and Transportation Officials, *A Policy on Geometric Design of Highways and Streets*, 2011.
2. American Association of State Highway and Transportation Officials, *A Guide for Achieving Flexibility in Highway Design*, 2004.
3. FHWA *Flexibility in Highway Design*, Federal Highway Administration, 1997.
4. American Association of State Highway and Transportation Officials, *Guidelines for Geometric Design of Very Low-Volume Local Roads ( $\leq 400$  ADT)*, 2001.
5. Joint AASHTO / FHWA Context Sensitive Solutions Strategic Planning Process, Summary Report, March 2007
6. Neuman, T., M. Schwartz, L. Clark, and J. Bednar., *A Guide to Best Practices for Achieving Context Sensitive Solution*, NCHRP Report 480, Transportation Research Board, 2002.
7. American Association of State Highway and Transportation Officials, *Highway Safety Manual*, 2010.
8. Transportation Research Board, *Highway Capacity Manual*, Transportation Research Board, 2010.
9. McGee, Sr., H. W., *Practical Highway Design Solutions*, NCHRP Synthesis 443, Transportation Research Board, 2013.
10. MoDOT *Practical Design Implementation Guide: Meeting Our Customer's Needs*, Missouri Department of Transportation (<http://www.modot.org/business/documents/PracticalDesignImplementation.pdf>)
11. Potts, I. B., D. W. Harwood, J. M. Hutton, C. A. Fees, K. M. Bauer, C. S. Kinzel, and R. J. Frazier, "Identification and Evaluation of the Cost-Effectiveness of Highway Design Features to Reduce Nonrecurrent Congestion," SHRP 2 Project L07 final report, MRIGlobal, 2013.
12. American Association of State Highway and Transportation Officials, *Geometric Design Guide for Resurfacing, Restoration, and Rehabilitation of Highways and Streets*, 1977.
13. Transportation Research Board, *Designing Safer Roads: Practices for Resurfacing, Restoration, and Rehabilitation Projects*, Special Report 214, Transportation Research Board, 1987.
14. Crump, E. T., ed., *Relationship Between Safety and Key Highway Features: A Synthesis of Prior Research*, State of the Art Report 6, Transportation Research Board, 1987.
15. Zegeer, C. V., and J. A. Deacon, "Effect of Lane Width, Shoulder Width, and Shoulder Type on Highway Safety," in Crump, E. T., ed., *Relationship Between Safety and Key Highway Features: A Synthesis of Prior Research*, State of the Art Report 6, Transportation Research Board, 1987.
16. Mak, K. K., "Effect of Bridge Width on Highway Safety," in Crump, E. T., ed., *Relationship Between Safety and Key Highway Features: A Synthesis of Prior Research*, State of the Art Report 6, Transportation Research Board, 1987.
17. Glennon, J. C., "Effect of Pavement/Shoulder Drop-Offs on Highway Safety," in Crump, E. T., ed., *Relationship Between Safety and Key Highway Features: A Synthesis of Prior Research*, State of the Art Report 6, Transportation Research Board, 1987.
18. Glennon, J. C., "Effect of Alignment on Highway Safety," in Crump, E. T., ed., *Relationship Between Safety and Key Highway Features: A Synthesis of Prior Research*, State of the Art Report 6, Transportation Research Board, 1987.
19. Glennon, J. C., "Effect of Sight Distance on Highway Safety," in Crump, E. T., ed., *Relationship Between Safety and Key Highway Features: A Synthesis of Prior Research*, State of the Art Report 6, Transportation Research Board, 1987.

20. Cleveland, D., "Effect of Resurfacing on Highway Safety," in Crump, E. T., ed., *Relationship Between Safety and Key Highway Features: A Synthesis of Prior Research*, State of the Art Report 6, Transportation Research Board, 1987.
21. Glauz, W. D., "Future Changes to the Vehicle Fleet: Effect on Highway Safety," in Crump, E. T., ed., *Relationship Between Safety and Key Highway Features: A Synthesis of Prior Research*, State of the Art Report 6, Transportation Research Board, 1987.
22. Harwood, D. W., E. R. Kohlman Rabbani, K. R. Richard, H. W. McGee, and G. L. Gittings, *Systemwide Impact of Safety and Traffic Operations Design Decision for 3R Projects*, NCHRP Report 486, Transportation Research Board, 2003.
23. Neuman, T. R. "Design Guidelines for Very Low-Volume Local Roads (< 400 ADT)," final report of NCHRP Project 20-7(75), CH2M HILL Chicago, Illinois: May 1999.
24. National Association of City Transportation Officials, *Urban Street Design Guide*, 2013

# 3 Highway Geometric Design and Project Development

## 3.1 Introduction

This research addresses highway geometric design and the need for a new geometric design process. The first major change should be to acknowledge that ‘geometric design’ as conventionally considered has little meaning absent the context in which the design is being completed. Geometric design has meaning and value only as it is applied to the context in which the designer is working – the geography, topography, land use, political, and environmental features within and adjacent to the roadway in question.

Textbooks and agency design manuals typically contain technical content describing how to calculate a feature such as an interchange ramp, or superelevated curve, or high point on a crest vertical curve. The geometry of angles, width and length dimensions, offsets, etc. is described. What is common to virtually all such treatments of geometric design is the absence of any background context information. [Indeed, in some cases concepts may be presented in such a simplified format that actually would never occur in a real setting; e.g., development of superelevation runoff on a zero grade roadway.]

Geometric designers don’t work in a vacuum. To the contrary, they can accomplish nothing without first understanding completely the full range of conditions, resources, constraints and opportunities with which they are confronted. So, for example, the development of a geometric alignment for a freeway entrance ramp may require the designer to design the ramp along a horizontal curve; with the diverge portion of the ramp occurring in conjunction with a sag vertical curve; all of which is necessitated by the context. Similarly, guidance to prefer 90 degree intersection crossings may need to be ignored because the intersecting roadways occur at an 82 degree crossing.

For the purposes of discussion, geometric design is thus better incorporated within the broader definition of highway project development, a term that includes many considerations beyond the mere geometry of the solution. Properly completed, the technology available to highway engineers enables the appropriate geometry to be applied to the context. And properly completed, it is the total performance of the solution (and not its geometry per se) that should be of paramount concern.

### 3.1.1 Highway Design Decision-making

Final decisions about the selected alternative and its specific design dimensions will be made by the owning agency, with input as requested from other agencies or external bodies. The decision process will often require the balancing of competing interests and trade-offs. Measurable performance goals will help to balance the trade-off decisions. These may include, for example, raised medians and access management for better traffic operation and greater safety, but at the cost of access to businesses. A footprint that supports better operation through an intersection may require right-of-way acquisition and come at increased cost.

The design process should be performed in a manner to provide sufficient data and objective information regarding the unique performance attributes of competing alternatives. The meaningful performance attributes of any road design solution can be categorized as follows:

- Implementation costs (typically initial cost of construction),
- Right-of-way acquisition or impact (total take, partial take; and type of land use acquired),
- Traffic operational quality (for motor vehicles, pedestrians, bikes, transit riders),
- Environmental effects (noise, air quality, wetlands, threatened and endangered species effects, cultural resources, etc.),
- Safety for both vehicles and vulnerable users (crash frequency and severity).

Current practice has evolved such that all of the first four items are or can be characterized in objective ways using the best practices of the design profession. DOTs typically maintain thorough and up-to-date records of construction bids and right-of-way acquisition costs, and have sophisticated cost estimating models based on quantity and other factors. The TRB Highway Capacity Manual has historically been the basis for best practices in traffic operations analysis procedures; current practice has evolved to incorporate sophisticated traffic simulation tools such as VISSIM, CORSIM, and Synchro which provide extensive quantitative performance data. A robust travel demand model can provide forecast data to get the best estimates of traffic operations for the alternatives under consideration. The traffic forecasts are as good as the assumptions that they are based on. Even in the case of environmental attributes, there are well-established, and in some cases set by regulations, the application of predictive methodologies to quantify environmental effects.

The fifth area, safety has historically lacked a consensus method for comparing different alternatives or evaluating highway geometry. It is common for project decisions on alternatives to be made without an attempt to quantify and compare the expected difference in safety performance. Any analyses that are performed typically fall into one of two categories:

- The crash rate for an existing condition ('no-build') may be compared with that for typical or average conditions in the State, with conclusions drawn regarding whether the existing condition is 'safe' or 'unsafe'. This analysis may often be used as part of a problem statement that may translate to a NEPA Purpose and Need statement.
- A 'nominal safety' analysis may be performed, in which an alternative's adherence to full design criteria is considered sufficient to demonstrate that the alternative will be 'safe.'

The highway design process should recognize the sensitivity of costs and impacts associated with requirements for marginal dimensions, and should produce outcomes that assure any such requirements will produce measurable benefits and demonstrate cost-effectiveness.

Finally, most design decisions, while informed by objective measures, are typically both subjective and not transparent; and also typically skewed to favor those project attributes that owners are most sensitive to and for which they have the confidence in the data provided. This is illustrated in Figure 3. Construction costs and right-of-way (both amount and cost) tend to predominate in decision-making. Differences in operational and safety performance will most typically not drive the decision, with the latter, safety performance, often not well

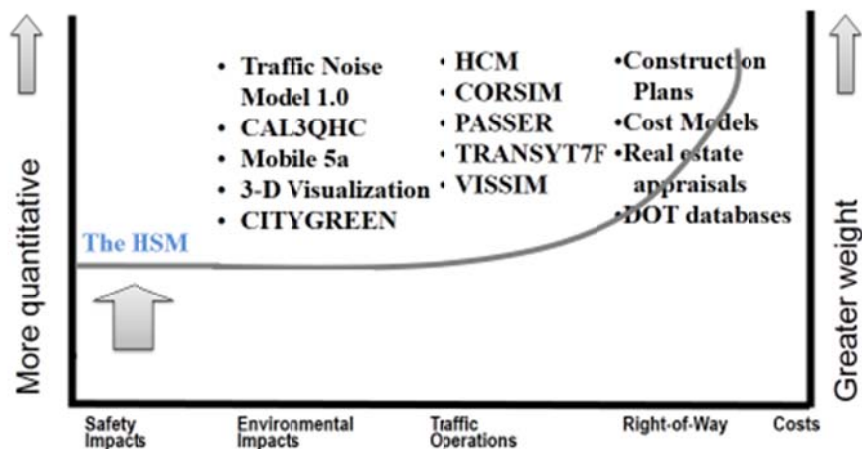

Figure 3. Costs and Right-of-way Dominate Design Decisions

understood at all.

### 3.1.1.1 Design Documentation

A final choice among multiple alternatives will ideally be fully explained to external stakeholders, be documented for future reference, and in the case of projects in NEPA be codified through a FONSI ('Finding of no significant impact') or ROD (Record of decision). Many agencies also produce Design Study Reports that document the specific design criteria and design decisions. Design Study Reports are typically prepared in conjunction with environmental documents, and describe what is often referred to as 30% design in which the three-dimensional footprint of the road is set. Bridge studies (referred to as 'type, size and location' or TS&L) may be included. Also included at this stage may be Design Exceptions or Design Deviations reports.

Design documentation is an important part of the design process. Complete documentation of the design and reasons behind it serve to defend the owning agency should there be a future tort action alleging negligence. More commonly, final engineering design documents may be prepared by individuals or even entities (consultants) other than those who produced the 30% design. Final engineering should reflect and support decisions made in the process by others.

### 3.1.1.2 Final Engineering Design

Once a preferred solution is selected, the geometric design process becomes more focused on providing details and additional features necessary for bidding and complete construction. This typically includes completion of all geometric and roadway details, traffic control plans, maintenance of traffic during construction, right-of-way plans, lighting and signing plans, utility relocation plans, guardrail and barrier plans, erosion control, pavement design, and construction specifications. During this process revisions to the preliminary geometric plans are common. These typically are associated with increased data obtained, constructability reviews, or final negotiations with affected stakeholders. In a well-executed project such revisions should have at most minor effects on the operational performance of the project that formed the basis for the decision.

Value engineering studies are required by FHWA for large projects and recommended for smaller projects. Value engineering as typically integrated into the design process is another source of revisions during the final design phase.

From the perspective of effort and cost, the great amount of detail required results in the final engineering stage costing three times or more than the cost of an alternatives study and preliminary design. At the close of this phase, the project will have advanced to a stage where it can be procured by the owner, most typically through a low-bid process involving qualified constructors.

## 3.1.2 Transportation Values Addressed by the Process

Agencies such as state DOTs will typically develop programs that respond to known or explicitly stated values of their constituency. The agency's fundamental mission is to provide transportation. How it does so reflects (or should reflect) those values of its constituents. DOT programs and policies are thus developed to implement projects that address such community values.

### 3.1.2.1 Core Values Reflected in Transportation Projects

The transportation values that create the priorities and ultimately define and shape the program and each project involve one or more of the following three basic needs:

- Maintaining transportation infrastructure in a ***state-of-good repair***.
- Providing or enhancing a transportation level of service which may include multiple modes, such level of service characterized by ***mobility, accessibility*** or both; and such service attending to both persons as well as goods.
- Enabling delivery of transportation service in a manner that is ***safe for all users***.

Projects involving ‘state of good repair’ may merely reflect the agency’s responsibility to properly manage the infrastructure it owns. They also contribute to a value characterized by ‘*comfort and convenience*,’ at least with respect to pavement surface.

Quite often there may be conflicting values for a project, such as regional mobility, local circulation and property access. The design process should seek to define all values so that trade-offs can be assessed.

Note that the above values should be viewed as applying to all potential users of the facility in any mode of travel. The values also should be considered in the context of those who may not directly use the road or corridor, but whose transportation needs may be influenced by the facility.

Characterizing all activities of and hence all projects performed by a transportation agency as addressing these fundamental transportation values is an appropriate framework in considering project development. Moreover, note that each basic core value can and should be quantifiable. Only by quantifying in meaningful terms what the project will produce in one or more of the core values can an agency both explain and defend its proposed solution, and be assured that its overall program is producing value.

### 3.1.2.2 Other Project Investments

Some projects may be funded and undertaken that have little apparent direct linkage to the above core transportation values. ‘Community re-vitalization’ projects may involve streetscape and landscape features that by themselves do not reflect the above values. Sound wall construction as a standalone project is another example of a project without a specific transportation function.

For the purposes of this research effort these projects are acknowledged as being aspects of an agency’s program, but are outside the transportation project framework presented here.

## 3.1.3 Objective of the Design Process

The objective of the design process should be the creation of a financially sustainable road system that delivers transportation values where they are needed, both now and in the future. Full understanding of this concept results in design decisions that do not just reflect the specifics of the individual project, but also consider 1)how the project ‘fits’ and functions within the immediate road network; and 2)how the allocation of resources to the project will influence the ability of the agency to complete other worthy projects.

### 3.1.3.1 Participants in the Design Process

Programming and scoping decisions establish type of project. Agency staff including chief engineers set design criteria and design policies. Assigned technical staff conduct the work using established methods and practices and apply the agency’s design standards and technical guidance. The following are typical technical disciplines involved in road design projects:

- Transportation planners
- Traffic engineers
- Environmental planners
- Environmental scientists
- Cultural resource experts
- Pavement and materials specialists
- Road safety engineers
- Highway engineers and geometric designers
- Drainage and hydraulic engineers
- Bridge and retaining wall engineers
- Public involvement and facilitation specialists
- Construction engineers.



External stakeholders may help define the problem, point out constraints or issues for the designers to consider, and review and comment. Some external stakeholders may have regulatory responsibilities requiring the owning agency to address to address the issues under their jurisdiction. The owning agency may need to address the regulatory responsibilities and outcomes required by certain external stakeholders. Any and all stakeholders may directly influence the design outcome. With respect to the actual solution, as owner, funder and operator of the project, the owning agency – a state DOT, for example, is ultimately responsible for the final design decisions.

### 3.1.3.2 Data and Knowledge Requirements

Highway design has classically been considered a civil engineering technical discipline. Geometric design, drainage and hydraulics, traffic engineering, geotechnical and materials science, and structural engineering are other core disciplines associated with highway engineering. Each discipline collects and processes data necessary to fulfill their roles on the project. These will include survey and base-mapping, soil borings, environmental resource surveys, traffic counts, travel forecasts or projections, and crash data.

In recent years many agencies have acknowledged the role of external non-technical stakeholders in projects. Community surveys, open house meetings, advisory committees and other efforts have been incorporated into projects to understand values and issues of affected stakeholders.

## 3.1.4 The Legal Framework in which the Road and Highway Design Process Exists

An important aspect of road design in the U.S. is the legal framework in which DOTs and roadway design professionals work. There are two important aspects to this framework – managing the risk of tort actions against owners and operators of the highway system; and federal and state laws and regulations governing environmental protections and processes.

### 3.1.4.1 Legal Liability of Highway Agency Owners and Designers

Actions of state governments are not immune from tort lawsuits. Road users involved in crashes may potentially bring tort actions against a state based on allegations of improper or negligent actions by their engineering and maintenance staff. In the context of road design projects, design errors or omissions may be alleged. Although the exact laws, limits and potential liability vary state by state, in general the following is true:

Professionals have what is referred to as a mandatory duty to perform their work according to established standards and practices of the profession, and following the policies of the agency for whom they work. Failure to fully perform their duties correctly can leave the agency open to a potential tort action should a crash occur that can be attributed to a problem associated with the road's design.

Decisions involving the professional judgment and discretion of professionals are generally not challengeable, as long as the decisions are fully documented such that they can be explained and defended as being reasonable and not arbitrary.

Hauer has noted that a necessary attribute of the highway design process in such a legal setting is the publication of and direct reference to design standards and criteria which are to be followed by design professionals. Such standards provide a clear benchmark against which an agency's discretionary design decisions can be proven to meet the professional standard of care. In simple terms, the design plans and accompanying design reports and documents should be able to be quickly compared to the standards and policies in place when the plans were produced. Again, while state laws and limits on discretionary immunity will vary, a road designer's first and most basic defense is the ability to prove that the plan as designed met all the relevant published design standards.

It is considered a given that the legal framework in which the profession works will remain in place. Any significant design process changes must produce design plans and supporting documents that enable an agency to 1) quality review the plans and documentation to assure it meets or exceeds the standard of professional care; and 2) be sufficiently clear and complete to serve to defend the agency against a tort action should that occur in the future.

### 3.1.4.2 Federal and State Environmental Processes and Regulations

Projects of any size and substance are subject to meeting the requirements of NEPA and the many related environmental regulations and laws. Projects that are not federal actions may be subject to comparable state regulations.

Highway projects, including design decisions that produce measurable or estimable adverse impacts, may be delayed or halted if opponents can successfully demonstrate that the owning agency and the FHWA did not appropriately identify and/or address such impacts.

Outside parties will generally not have standing to sue because they do not support the final decision. Such decisions are discretionary acts of government and immune from suit as long as the overall project process, individual sub-processes and tasks, and technical efforts can be shown to meet the standards of professional practice.

Over the past 30 years research on understanding environmental consequences of design actions has produced a large body of knowledge. Sophisticated tools for modeling environmental effects such as noise, air quality, economic impacts, and health impacts are now part of professional practice. Most DOTs have experienced at least one instance in which external stakeholders have been able to demonstrate to a court that some technical aspect of a project was not conducted properly. In some cases failure to appropriately consider all reasonable alternatives was sufficient to stop a project.

Effective decision-making processes include a stakeholder-inclusive discussion and enumeration of what decision criteria, effectiveness measures and relative importance of the criteria are to be employed to make the decision among competing alternatives. The study and decision processes employed will include meaningful measures of the unique community values which will typically encompass both transportation values (mobility, access, and safety) and other non-transportation values. In virtually every project, there will be issues of environmental sensitivity that will influence the generation and acceptability of alternatives as well as their performance attributes and outcomes.

Roadway design decisions inherently involve trade-offs and judgments, with many of these involving environmental issues. The level of detail associated with quantifying environmental effects is increasingly greater. Future design processes should strive to match detail with better and more complete information on performance attributes of a design.

## 3.2 Key Findings on the Highway Design Development Process and Need for Design Process Changes

Chapter 2 outlined the evolution and progression of highway design in the U.S. in response to societal changes, public policy initiatives, and technological advances. The framework outlined above captures values, objectives, and public policy framework within which highway and road projects must be developed. With this introductory background, the research team, with confirmation of the research panel, posits 16 basic findings that form the basis for recommended changes to the road design process in the U.S. These are summarized below.

### 3.2.1 Finding No. 1

#### Interdisciplinary project development is here to stay (Institutionalization of Context Sensitive Solutions)

The stakeholder-driven process referred by some as ‘Context Sensitive Solutions’ is here to stay, whether by that name or some other names. Direct involvement of stakeholders, many of them external to the owning agency and many with varying roles, is now accepted as how highway projects are to be developed. The AASHTO Policy document *‘A Guide to Achieving Flexibility in Highway Design’* endorses the concept of stakeholder involvement in

the design process. Many state DOT project development processes now directly incorporate reference to stakeholders and their input, but the experience in full implementation is uneven.

Stakeholder interests include both transportation and non-transportation values and concerns. Project development – including especially the highway design process -- must address such concerns through workshop and public involvement tasks, targeted analyses and design studies, and formal evaluations, many of which must meet regulatory requirements. Listening and gaining a true understanding of concerns is an important part of this process. Projects with even modest budgets and scopes now routinely include technical input from multiple disciplines.

The stakeholder process potentially increases the complexity and often the time needed to complete the project. It demands that owners fully investigate a range of design alternatives including cross section, alignment and traffic operational options. Multiple interests translate to competing priorities, especially for projects with important limitations of budget, space or right-of-way; and also with multiple problems or needs to address. In most projects in urban settings the highway or road is no longer designed for motor vehicles alone, but must address other modes including vulnerable users such as pedestrians and bicyclists, often within a pre-defined limited right-of-way envelope.

All of the above reinforce the notion that road and highway design is in many ways the exercise of choices by the designer (the owner), such choices reflecting judgments about meeting the project's objectives while addressing the full range of often conflicting stakeholder interests. This process is not separate from design – it is central to it. Highway designers and engineers need to understand that this is part of their job – to seek, assemble, review and deal with stakeholder input. Such understanding also translates to a need for designers to have good communication skills in addition to their technical skills.

***The AASHTO Policy on Geometric Design should explicitly describe both the substance of and process by which highway designers seek and incorporate stakeholder input as an integral part of the highway design process.***

## 3.2.2 Finding No. 2

### Context matters – and it varies

A project's context as broadly defined matters greatly with respect to what is physically possible to construct, what is reasonable to expect in terms of both operational and safety performance, what performance in fact will occur, what direct implementation costs are incurred, and what socioeconomic and environmental effects may result. The AASHTO highway context framework is limited in that it only reflects general considerations of the cost or difficulty of construction, and the traffic operational trade-off associated with mobility vs. access. It also lacks sufficient depth. Context varies greatly, and in many more ways and dimensions than the current AASHTO design process defines context.

***The AASHTO context framework as currently defined by location (urban, rural), functional classification (arterial, collector, local road) and terrain (flat, rolling, mountainous) does not adequately capture the full range of context variance as it influences roadway or highway design development. Two important context features should be included -- the presence of vulnerable highway users and the type of project.***

#### 3.2.2.1 Context and Vulnerable Users (Pedestrians and Bicyclists)

Where service for motor vehicles is of paramount interest the operational performance of the road is measured by travel time, which in turn is influenced by speed. Higher design speed facilities are thus favored and promoted by policy. However, there are clearly situations in which the right overall solution should promote and enforce operating speeds that reflect the presence of road users particularly vulnerable to conflicts with vehicles at moderate to higher speeds.

*It is current national policy to promote walking and bicycle riding. Trends for both types of travel are strong and expected to continue. As of 2012, 1 in 6 of the total number of highway fatalities nationally are pedestrian and*

*bicycle related. The AASHTO design process must explicitly acknowledge the importance and relevance of these road users.*

In the urban environment vulnerable user activity (pedestrians and bicyclists) must become increasingly more important as a fundamental control and input to road design. For some projects the transportation problems or needs will be focused on such users. For many other projects, the mere presence of vulnerable users in sufficient numbers clearly shapes the setting of performance measures and development of reasonable solutions. What is needed is a process, based on readily attainable data, which defines contexts in which meeting the needs of vulnerable users is of primary importance. Initial thoughts on this subject are offered here, to be more fully developed.

Land use as a context definer offers a simple and intuitively appealing approach to defining the propensity for significant pedestrian activity. The extent of pedestrian activity varies widely based on both the type of land use adjoining a roadway and the density of the land use. Streets designed in downtown urban cores fronted by high-rise commercial properties experience high volumes of pedestrians walking along and crossing the roadway on a regular and frequent basis. Expectations of both motor vehicle operators and pedestrians themselves reflect the land use context. Both spatial demands for pedestrians as well as operational considerations where pedestrians and motor vehicles compete for mobility will influence road design solutions.

The current road design process lacks a means of sufficiently differentiating and defining land use contexts in which pedestrian and vulnerable user considerations are of such importance that they should 'drive' the design process and solutions. AASHTO's reference to 'urban' is clearly insufficient.

The Institute of Transportation Engineers' recently published Recommended Practice for Walkable Thoroughfares outlines a Context Zone framework that is useful and could be directly applicable as an expanded context identifier, as illustrated in Figure 4.

Seven context zones are described by both type and intensity of land use. Guidance for appropriate design controls that reflect sensitivity to vulnerable users, including specifically speed, are presented. This framework offers a starting point for discussion about how to define the full range of contexts.

***A formal process is needed for identifying contexts in which vulnerable users should be expected, and hence different approaches to speed and operational needs should be adopted.***

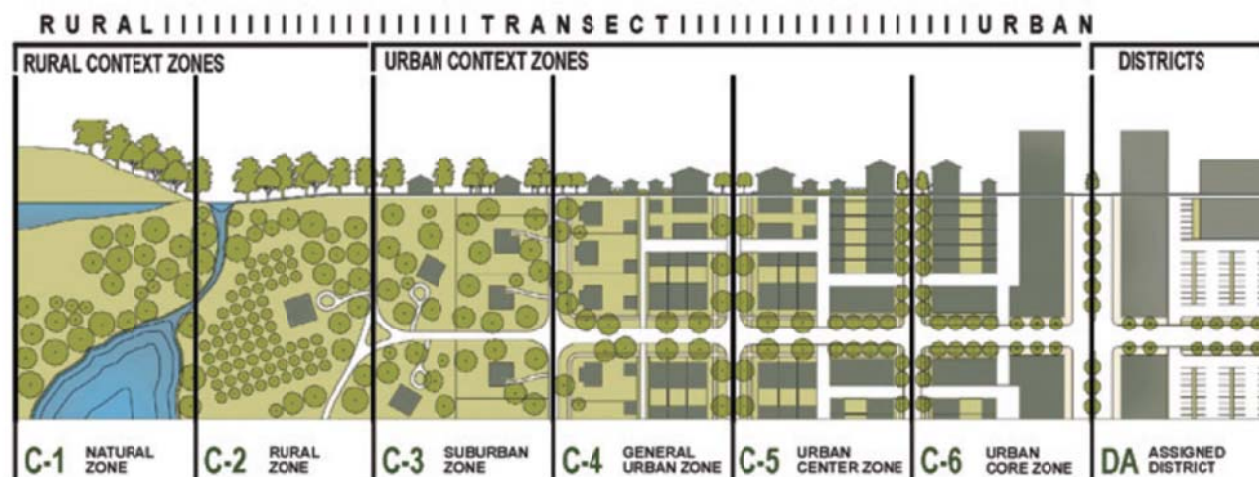

Figure 4. Roadway Context Zones

Source: Institute of Transportation Engineers, *Designing Walkable Urban Thoroughfares: A Context Sensitive Approach – ITE Recommended Practice*

### 3.2.2.2 Context as Defined by Project Type -- The Differences between Reconstruction and New Construction Projects

The AASHTO Policy considers new construction and reconstruction projects to be the same with respect to applicability of design policy. The historic basis for this assertion is unclear, but it presumably relates to the concept that, geometrically, a road undergoing complete reconstruction should be designed to current, updated design criteria. Such a judgment, though, ignores important aspects of the differing contexts around both project types.

By definition a reconstruction project involves a roadway already in place and functioning. Similarly, a new construction project (one on new alignment) introduces a new transportation corridor where none exists. The following differences are evident:

- With an existing road the abutting land use has developed around the mobility and access provided by the road; with a road on new alignment the road itself always produces significant change (both positive and potentially negative).
- With an existing road there is a clear and well understood operational and safety performance history; none exists for a road on new alignment.
- The costs of construction and constructability of each project type are based on significantly different factors.

#### 3.2.2.2.1 Land Use Context Differences

Abutting land uses evolve and develop around the traffic service provided by an existing road. In more developed locations land use will be fully occupied by buildings, parking, plazas, or setbacks established by local land use ordinances. Developments form the economic and social fabric of the community, and are the source of employment and tax revenues. Reconstruction of an existing road should bear a burden of minimizing damage or disruption to property owners (businesses, residents, government agencies) who invested in their land based on the right-of-way and footprint of the existing road.

Reconstruction projects that require taking of new right-of-way will inevitably produce adverse impacts beyond the direct cost of the right-of-way itself. Design philosophies and solutions for reconstruction projects should thus properly focus on what will 'fit' within the existing right-of-way, an exercise that may influence not only cross section but also alignment. Finally, reconstruction projects will frequently produce changes in access. In most cases these will be considered adverse by the abutting property owners (e.g., closing of driveways, or their consolidation or relocation).

Roads on new alignment by contrast involve right-of-way acquisition for the entire corridor. Such projects are typified by studies of alternative independent alignments, with the availability, adverse effects such as severances, and cost of the right-of-way key factors in selection of a preferred alignment. Designers will generally have more latitude in identifying feasible corridors. Finally, the addition of the road itself to the local context almost always represents a net improvement in transportation service (mobility or accessibility) given that no such service preceded the road.

#### 3.2.2.2.2 Operational and Substantive Safety Performance History

Perhaps the most significant difference between reconstruction and new construction concerns the transportation performance history of the facility. In the latter case it simply does not exist. Indeed, the design process must rely on travel demand forecasts for volume and pattern of traffic that are inherently uncertain. There is no way to directly observe how drivers will respond to the finished solution in terms of their speed behavior, navigation, or decision-making. Reliance on simulation and other models of expected driver behavior must suffice. Finally, the expected safety performance can only be estimated based on the knowledge base and models from the Highway Safety Manual or other sources.

With existing roads to be reconstructed the designer will have a complete understanding of the traffic operational and safety performance of the existing road over time. This can include direct observations of traffic volume by

time of day, delay, of speed and speed behavior, travel time, gap acceptance and conflicts. It should also include a complete set of data and observations on the frequency, types, severity and other characteristics of crashes over whatever time period is necessary to reach full understanding of the safety performance.

Most roads undergoing reconstruction will be 30 years or older. In most cases their geometric features will reflect AASHTO or equivalent design policies from 1984 or earlier. Given the periodic changes in design policy since 1984 it will be commonplace for one or more geometric features to not meet current criteria. The existing road thus may or may not include geometric features that are ‘nominally unsafe’, i.e., do not meet current criteria. *Roadway design standards – nominal safety – are a means to an end, that end being performance.* The presence of a nominally unsafe condition or feature is not a transportation problem – it is a condition of the context. In the absence of an associated measurable transportation problem (safety or operational) there will be no performance value obtained in upgrading the road to current standards. Moreover, as noted above, given the context of fixed right-of-way any such upgrading whether for cross section or alignment will invariably create significant adverse impacts and costs to adjoining properties and stakeholders.

Any and all reliable data describing actual transportation performance that can inform the design process should be directly incorporated into that process. Highway design for reconstructed roads thus offers a level of knowledge and understanding not available for new alignment projects. Incorporation of such knowledge into the reconstruction design process is a significant differentiator that should be explicitly acknowledged in design policy and process.

### 3.2.2.2.3 Construction Costs and Constructability

Design criteria per AASHTO are based in part on the notion of cost-effectiveness, which is based on cost elements of the quantities of new pavement, structures and earthwork balance. Such considerations will drive the design process of a roadway on new alignment as they have historically.

The difficulty and resultant costs of reconstructing an existing road are much more heavily influenced by factors other than material costs or pavement or earthwork. Reconstruction in most cases must accommodate existing traffic service on the corridor while construction occurs. Costs of multiple project phases with traffic control switches, detours, temporary pavement and closures can amount to 30% or more of a reconstruction project, and in many cases be the deciding factor in a final design solution. Vertical alignment controls reflect need to maintain access points and intersections during construction; earthwork balance is at best a secondary concern. Clearly, the implied cost-effectiveness relationship of criteria based on construction of new alignment does not translate to reconstruction.

### 3.2.2.2.4 Potential Design Process Improvements for Reconstructed Highways and Roads

The ability and indeed responsibility to fully study and incorporate knowledge of the existing performance of a road to be reconstructed is a substantial benefit to the design process for such projects. The design process for reconstructed roads should address this information, with solutions reflecting specific performance. Such a process may produce the following:

- Existing geometry regardless of whether it meets criteria or not could presumptively be identified as adequate based on a thorough review of the safety and operational performance.
- A road with a ‘nominally unsafe’ geometric element (i.e., one not meeting current criteria) could retain such element if a thorough review of the safety and operational performance history deems the geometry to be satisfactory; or if a demonstrated performance problem was determined to be unrelated to the geometry.
- Retention of existing geometry could by policy be approved with such analyses and without the labeling and need for a design exception.

Design criteria could be expressed in a way that directly allows retention of a design feature based on performance analyses. Note that there are hints of differentiating for reconstruction already in the AASHTO Policy on Geometric Design. Table 6—showing the headings for lane and shoulder width design values—has a footnote

that addresses the safety and operational performance of existing roads within the context of establishing a need for widening.

Table 6. Example of Performance-Based Criteria from Current AASHTO Green Book

Metric					U.S. Customary				
Design Speed (km/h)	Minimum Width of Traveled Way (m) <sup>a</sup> for Specified Design Volume (veh/day)				Design Speed (mph)	Minimum Width of Traveled Way (ft) <sup>a</sup> for Specified Design Volume (veh/day)			
	under 400	400 to 1500	1500 to 2000	over 2000		under 400	400 to 1500	1500 to 2000	over 2000
<p><sup>a</sup> <i>On roadways to be reconstructed, an existing 6.6-m [22-ft] traveled way may be retained where the alignment is satisfactory and there is no crash pattern suggesting the need for widening.</i></p>									
<p><sup>b</sup> Preferably, usable shoulders on arterials should be paved; however, where volumes are low or a narrow section is needed to reduce construction impacts, the paved shoulder width may be a minimum of 0.6 m [2 ft] provided that bicycle use is not intended to be accommodated on the shoulder.</p>									

Source: Table 2-7 AASHTO Green Book

Such process improvements would represent an appropriate emphasis on performance rather than roadway geometry as a surrogate for performance. They would eliminate costly, no value solutions ('upgrade to standards') and reduce the bureaucracy of needless design exceptions. The process could be suitably flexible in its construct to allow agencies to select decision-performance thresholds based on availability of funds, priorities for certain road types, or any other factors deemed important. Finally, such a process would directly incorporate a strong incentive for a designer to undergo proper evaluation of the performance of the existing road in order to garner the value in cost savings associated with retaining the existing geometry.

### 3.2.3 Finding 3

#### Providing multimodal solutions is now the rule and not the exception

The geometric design process, historically focused solely on motor vehicles, must evolve to more directly and routinely address the needs of all potential users of a facility or corridor. Both process and cultural change within the road design community are needed. There are inherent conflicts and choices to be made in prioritizing the amount and manner of transportation service afforded general purpose traffic, transit, truck and freight traffic, bicyclists, and pedestrians. The design process should direct the resolution of such conflicts and the establishment of choices among all needs.

**With respect to process, more refined context definitions are needed to identify corridors and conditions in which, for example, pedestrian needs should take precedence over motor vehicles. The law requires pedestrian facilities to comply with ADA Requirements. Similarly, the presumptive need to design cross sections, intersections and vertical alignment recognizing the presence of bicycles is also desirable. As noted above, land use variables, including type and density of use are possible context definers that may be included.**

### 3.2.4 Finding 4

#### AASHTO dimensional criteria should be ideally based on known and proven measurable performance effects

The AASHTO Policy is over 1000 pages long and continues to grow with every edition. Much of the growth in contents stems from advances in research knowledge, but also expansion of considerations that were not important or even existed in previous years. Designers are confronted with increasing demands and urged to be 'flexible' in their approaches. DOT manuals based on the AASHTO Policy are generally written in a manner that removes flexibility. Too many designers don't understand the relative importance of a given criteria, or are not allowed to exercise judgment in ignoring or violating a criterion.

There remain within the AASHTO Policy and state DOT manuals examples of design criteria that are based on outdated rational models or assumptions that in practical terms offer no meaningful value. Criteria for minimum length of curve, for ratio of compounded horizontal curves are two examples.

**Dimensional criteria published by AASHTO should reflect known, proven and meaningful operational or safety performance effects. The guidance in the AASHTO Green Book that is not based research but is based on past practices and professional judgement should have research conducted to either verify that the guidance provides for the desired operations and safety results or revise the guidance.**

### 3.2.5 Finding 5

#### Speed is an essential input to determination of design values and dimensions

The design process is significantly reliant on speed as a central input or control. Current AASHTO processes incorporate the concept of 'design speed.' ITE and others have suggested the use of 'target speed.'

Regardless of the term used, development of design dimensions and details will to a great extent require the setting of speed control or variable. Speed clearly influences distances vehicles travel while maneuvering. Speed directly influences the severity of conflicts and crashes. The design process requires a framework and starting point (i.e., 'design controls'). Speed, or the 'speed regime' in which the road is to operate, is arguably the most important control to establish. Moreover, the need to specify a speed as the basis for a design includes documentation of the design within the legal framework.

Besides being a critical component to design criteria, speed must be acknowledged as having conflicting contributions to transportation performance. Historically, speed has been a surrogate measure of quality in that the prevailing transportation value was travel time (i.e., its minimization). Travel time and hence speed continue to be important in this regard. However, the adverse effects of speed on safety performance must also be considered.

Non-technical stakeholders recognize what is documented in the research (see Figure 5). The

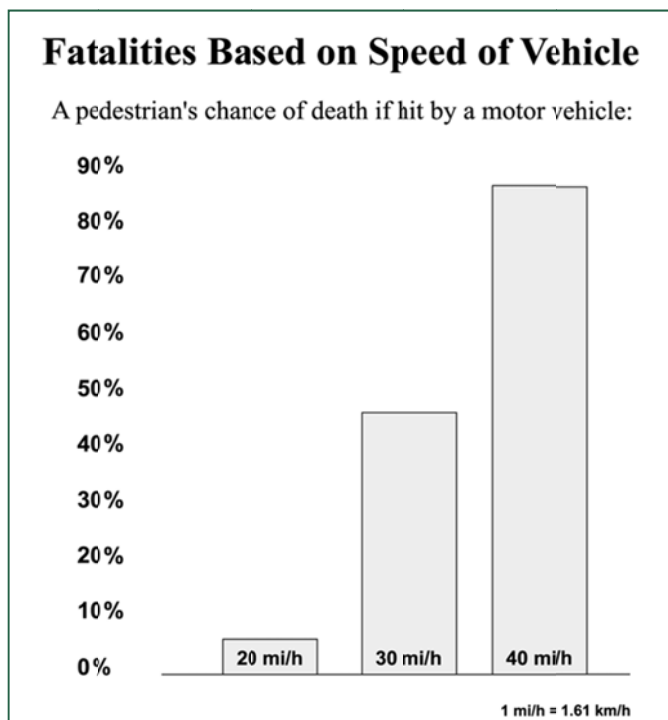

Figure 5. Adverse Effects of Speed on Safety Performance



survivability of vulnerable users in crashes decreases dramatically as the speed of the collision increases. Providing or encouraging a high speed environment under every possible context does not appear to be an appropriate approach. In some situations, reducing the speed could be considered an effective solution to reduce crashes.

***The design process and AASHTO guidance will by necessity continue to require the setting and application of selected or assumed speeds as a fundamental design control.***

***The design process and AASHTO guidance will also by necessity require the identification of those contexts and circumstances in which high speed operations should not be encouraged because of the increased risk to vulnerable road users.***

### 3.2.6 Finding 6

#### AASHTO Design Criteria produce uneven outcomes re: performance

AASHTO design criteria have evolved over the years. In some cases models and assumptions have remained unchanged over time (e.g., stopping sight distance, horizontal curvature); in others research has resulted in wholesale changes to the design approach (e.g., Intersection Sight Distance, Passing Sight Distance); and in still others significant changes in design values have resulted (lane and shoulder widths on two-lane rural roads).

To our knowledge the entire set of basic geometric design criteria have never undergone a thorough, holistic review. Under current policy the models and approaches vary widely. The input assumptions and basis for design criteria reflect differing value judgments, which in turn produces varying performance. As summarized in Table 3:

- Horizontal curve design is based on providing comfort,
- Lane and shoulder width design are based on safety performance for two-lane rural highways,
- Stopping sight distance is based on a theoretical model lacking evidence of its relevance to actual events and operations,
- Maximum grade is based on heavy vehicle operations,
- Roadside design is based on explicit analysis of safety performance.

Many basic AASHTO models apply across the full range of road types and contexts. Such a simplistic approach to design has yet to be questioned. It may be that more context-specific models and input parameters would yield more cost-effective and reasonable solutions within application of the policy.

As a follow up of this finding, a detailed evaluation of the design criteria was conducted as part of this research. Refer to Section 6.5 for additional discussions on this topic.

***Given the above it is not possible to assert that the application all design criteria as currently published in AASHTO will produce uniformly or programmatically cost-effective outcomes.***

### 3.2.7 Finding 7

#### Many AASHTO criteria are not sensitive to key context attributes that are proven influencers of performance and cost-effectiveness

AASHTO criteria are presumed by users to be directly related to safety performance. The underlying principle of cost-effectiveness is also presumed to apply to the use of AASHTO criteria. As noted previously, two fundamental variables central to the concept of safety performance and overall cost-effectiveness – traffic volume and type of road -- are not present in the formulation of many basic AASHTO design models.

Per Table 7, horizontal curvature, stopping sight distance and lane width for urban and multi-lane facilities are derived independent of design year traffic and road type. Horizontal curves are designed per AASHTO using the same model for roads with 500, 5000, 50,000 or more vehicles per day, and for two-lane highways, multilane highways, and the full array of access-controlled facilities alike. Yet the expected safety performance of any curve,

which translates directly into cost-effectiveness, will clearly differ in meaningful ways for the volume and road type conditions noted above.

Empirical models of safety performance based on Highway Safety Manual research confirm that the risk of a crash varies by road type. For both segments and intersections, the following is known:

- The frequency of crashes by type varies widely for two-lane versus multilane roads; and roads in urban vs rural areas.
- The effect of specific geometric variables and dimensions on safety performance also varies by roadway context.

Design criteria properly applied should generally produce cost-effective solutions in any combination of context and traffic volume. The formulation of current design criteria does not do this. It is possible that in some contexts design criteria are overly restrictive, producing no meaningful performance benefits for the increment of additional costs required. In other cases, application of current design policy may inadvertently miss the garnering of performance benefits with no or minimal increase in cost. In the view of the research team, reaching the goal of having cost-effective design criteria must mean the incorporation of traffic volume, and road type in the formulation of such criteria.

***Any geometric criterion or design model lacking sensitivity in its formulation to traffic volume and road type cannot be assumed to produce cost-effective solutions when applied across the full range of design conditions.***

Table 7. AASHTO Criteria Evaluation

Design Element	Functional Model Basis	Model or Design Assumptions	Incorporates Design Speed?	Incorporates Empirical Substantive Safety or Human Factors Research?	Sensitive to Traffic Volume?	Sensitive to Functional Classification or road type?	Sensitive to Variances in Vehicle Type?	Incorporates Interactive Effects of Other Roadway Elements?	Comments	Research Basis for AASHTO Policy
<b>Horizontal Alignment</b>										
Radius of Curve	Passenger car produces acceptable threshold of comfort operating at design speed	Vehicle operates at constant design speed tracking the center of the designed curve throughout its length	Yes	Yes* -- dated studies of driver discomfort operating on curves	No	No	No	No	Studies of actual operations on curves conflict with AASHTO assumptions	
Length of Curve	Length, radius and central angle between tangents are interrelated geometrically	Length and/or Central Angle are not currently included in design policy as controls	NA	NA	NA	NA	NA	Trade-off involving curve radius and length produces varying quantitative safety performance for the same central angle	Not explicitly covered in design policy	
Superelevation	Superelevation counteracts side friction on 'one to one' basis	Passenger car exactly tracks road as designed at constant design speed	Yes	No	No	No	No	No	Studies of actual operations on curves conflict with AASHTO assumptions	
<b>Vertical Alignment</b>										
Maximum Grade	Truck Operations on upgrades	Ability to reach sustained speed for assumed WT/HP for heavy vehicles	Yes (initial speed)	Yes -- research relating speed differentials to rear-end conflicts	No	Yes	Yes	Grade and Length of Grade combine to produce the speed of the vehicle	Criteria do not reflect ability of bicyclists to operate on steep and/or long grades	
Minimum Grade	Pavement Drainage		No	No	No	No	NA	Minimum grade, superelevation and cross-slope all produce cross section that drains	Criteria do not reflect frequency and/or intensity of precipitation	
Crest Vertical Curve	Provide stopping sight distance	See Sight Distance above; operation at design speed with assumed eye height and object height		No	No	No	No	Vertical curve length is directly related to intersecting tangent grades	Sight distance profiles produced by combinations of grade and vertical curve length vary	NCHRP Report 400
Sag Vertical Curve	Visibility of pavement at night; headlight beams; also comfort in the extreme if headlight beam criteria cannot be met	Assumed headlight height and beam spread	Yes	No	No	No	No	Vertical curve length is directly related to intersecting tangent grades		
<b>Cross Section</b>										
Lane Width	Widths for two-Lane Rural Highways based on cost-effectiveness analysis including both substantive safety and traffic operations	NA	Yes	Rural Two-Lane Highways Only	Rural Two-Lane Highways Only	Yes	No* (exception is guidance for lane widening on horizontal curves where trucks are present)	Rural Two-Lane Highways Research Basis Reflects Combined effects of lane and shoulder width		NCHRP Report 362
Shoulder Width	Widths for two-Lane Rural Highways based on cost-effectiveness analysis including both substantive safety and traffic operations	'Full width' shoulders are considered 10-ft or more	Yes	Rural Two-Lane Highways Only	Rural Two-Lane Highways Only	Yes	No	Rural Two-Lane Highways Research Basis Reflects Combined effects of lane and shoulder width		NCHRP Report 362
Cross Slope	Pavement Drainage		No	NA	No	Yes (greater slopes on lower class roads; and on wider pavements)	NA			
Median Width	Separate Opposing Traffic	Varying widths associated with intended function(s); e.g., separation, incorporation of left turn lane(s), access control, enable provision for physical barriers	No		No	Yes -- applies to multilane roads only; freeways require minimum dimension for shoulders and barriers	No	Median type (raised vs flush)	Medians not required for non-freeway facilities	

Sight Distance										
Stopping	Collision avoidance with object in road	Passenger car operating at design speed brakes to full stop; single values for object height, eye height, reaction time and deceleration rate. Horizontal sight line assumed to be center of roadway/lane with sight line to object at center of roadway/lane.	Yes	Changes in model parameters based in part on review of crash records of objects struck by size	No	No	No	Yes -- effect of grade on stopping length	Original derivation of object height based on cost-effectiveness calculations of construction costs; NCHRP Report 400 resulted in change to a meaningful object height	NCHRP Report 400
Intersection	Gap Acceptance for vehicles on minor approach	Driver requirements for gaps based on range of cases based on type of maneuver (turning, crossing) with sight lines based on design driver eye height and vehicle height for range of vehicle types	Yes	Yes	No	Yes (Cases categorized by urban, rural)	Yes	Yes -- presence of intersections; effect of approach grade		NCHRP Report 383
Passing	Distance required for vehicle to complete or abort a passing maneuver	Passenger car undertaking passing maneuver assuming speed differentials, acceleration capabilities and available sight distance with design driver eye height and design vehicle height	Yes	Yes -- observations of passing maneuvers	No	Applies to two-lane rural highways only	No	No		
Decision	Distance for driver to detect unexpected or difficult to perceive information source or condition; recognize it, select speed and path, and initiate complex maneuvers. Human Factors requirements for complex actions	Human Factors -- Based on time requirements for five cases involving range of contexts and operating conditions.	Yes	Yes	No	Yes (Cases categorized by urban, rural)	No	Yes -- e.g., presence of intersections	DSD is not required but considered advisory or good practice	
Roadside Design										
Lateral Offset	Operational offset for car doors, side mirrors, etc.; also potential for impact with roadside objects		Yes	Yes	No	Yes	No	Yes -- 4 ft lateral offset on moderate to higher speed roads without vertical face curb		
Side Slope	Ability to recover given encroachment	Vehicle leaving roadway at design speed	Yes	Yes	No	No	Yes	Yes -- Clear Zone		
Clear Zone	Ability to recover without overturn or striking an object given encroachment beyond edge of pavement		Yes	Yes	Yes	No	No	Yes -- Side Slope and Shoulder width		
Vertical Clearance										
Vertical Clearance	Provide at least 1-ft vertical clearance to maximum legal height vehicle	Legal height of vehicle is 13 ft	NA	Yes*	No	Yes, greater dimensions for freeways and Interstates	No	No	Tunnel clearance is special case	



### 3.2.8 Finding 8

Some AASHTO criteria are unnecessarily simplistic in their formulation, or are based on models that are lacking a proven science basis

The AASHTO policy emerged from a recognized need in the 1930s and 1940s for formal design direction. At that time there was little if any scientific or empirical knowledge about human factors, traffic operations or safety performance. Originators of the AASHTO policies relied on simplifying assumptions and simple rational models based on fundamental concepts of physics. Examples include:

- AASHTO Horizontal curve model which assumes constant operation of a passenger car at design speed independent of upstream alignment effects; with the vehicle tracking the center of the roadway.
- Stopping sight distance model which assumes passenger car operation at design speed and hard braking to a full stop to avoid collision with a fixed object.
- Horizontal sight distance model which defines the offset assuming a driver eye location at the center of the lane, and a point fixed object at the center of the lane.
- Cross slope rollover criteria based on the assumption that the rollover itself is the critical operating condition.
- Design guidance for interchange ramp design speed expressed as a percentage of the freeway's design speed.

In each of the above examples either the models themselves or the assumptions used in them are overly simplistic, have been proved to be incorrect in actual operation, or in some cases not based on any science. Some simplifying assumptions reflect the pre-computer era in which graphical techniques were used or calculations made by hand. (For example, there is no reason why horizontal sight lines cannot be defined based on more appropriate placement of the driver's eye in the lane, and also place the object at different spots across the width of the lane. These assumptions would provide significantly different horizontal offsets based on the direction of the curve itself.)

Glennon and Neuman confirmed 25 years ago that drivers do not track horizontal curves as assumed, but rather 'overdrive' them. Krammes et al showed that the assumed speed behaviors produced through curves did not replicate AASHTO assumptions (see Figure 6).

In particular, the research team has concern over the simple models for horizontal curve design and stopping sight distance, which have not been challenged nor substantially changed over the years. As both of these are core criteria that heavily influence geometric design, they warrant substantial further study.

***A highway design process applicable to the wide range of contexts, and intended to produce cost-effective results, requires design models and criteria sufficiently sophisticated and robust, and directly linked to research knowledge on operations and/or substantive safety.***

### 3.2.9 Finding 9

The legal framework requires the provision of threshold limits for design criteria and design values; the question is – how should such lower limits be set?

Even assuming perfect knowledge of safety and operational performance, it is questionable whether a design process that relied totally on performance models would suffice. Risk managers confirm the importance of published criteria. The design profession has relied on such criteria throughout its history.

The question of what should constitute minimum dimensional criteria is to an extent a philosophical one. The authors of NCHRP Report 400 introduced the theoretical risk model of SSD, shown in Figure 7. Even if it is agreed that a safety risk-based approach is appropriate for SSD, and the actual shape of the curve could be established

for a range of contexts through research, one still must decide where to 'draw the line,' i.e., how much risk should be codified in the minimum design dimensions?

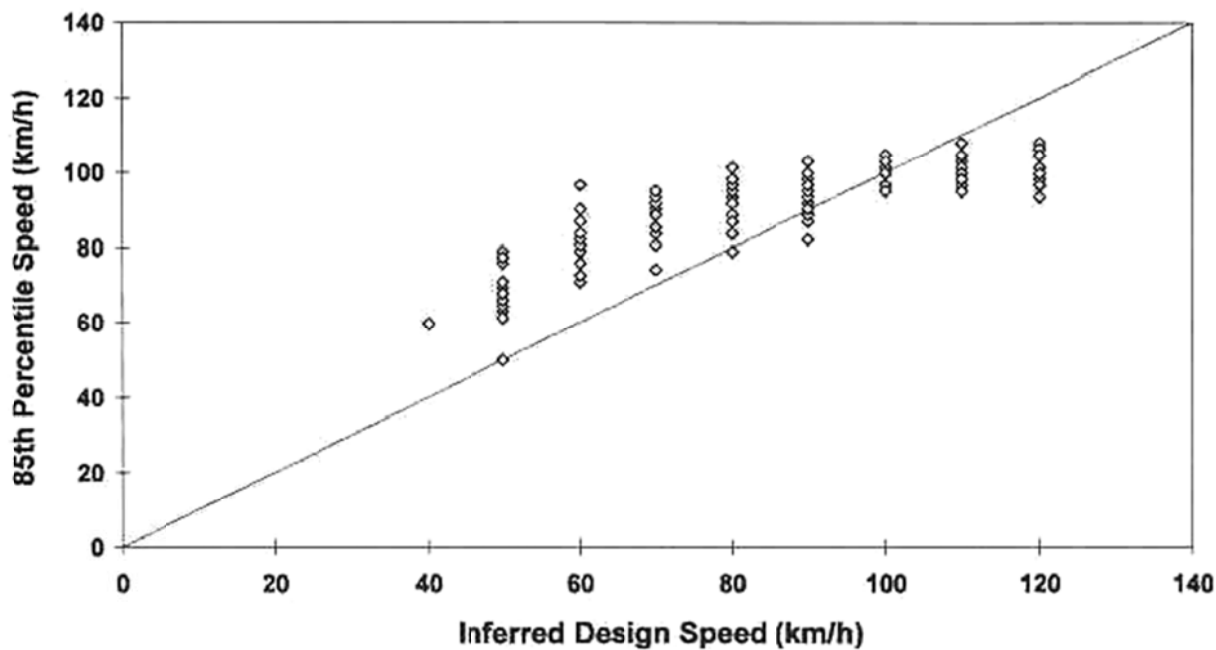

Figure 6. Comparison of Actual vs Assumed Driver Speed Behavior by AASHTO Curve Design Model

Source: NCHRP Report 400

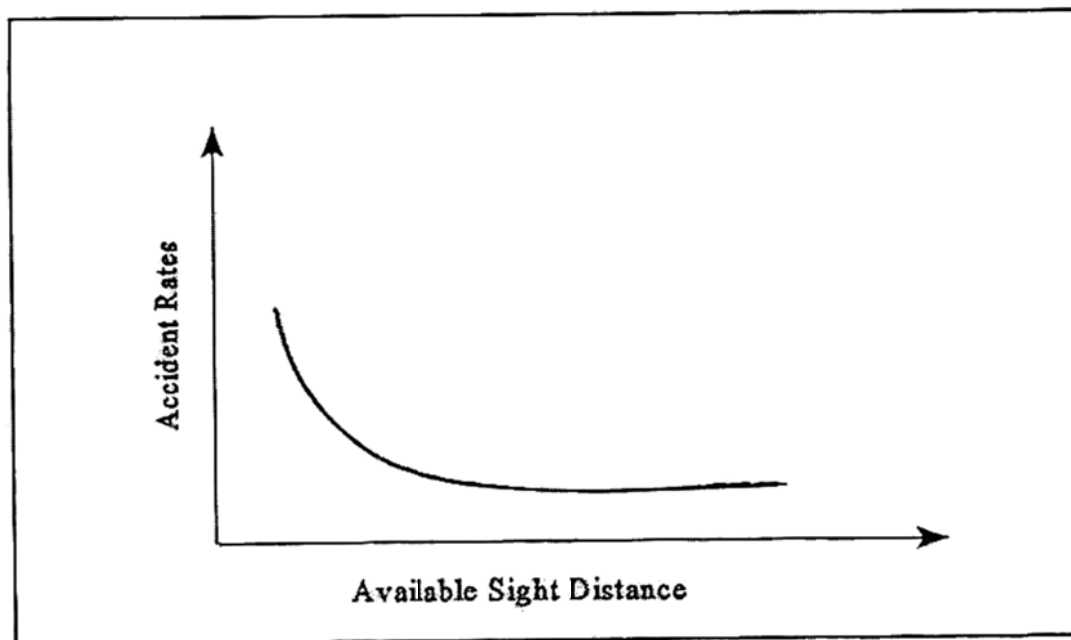

Figure 7. What is Acceptable Risk as the Basis for Design Criteria?

Source: NCHRP Report 400

We cannot nor should we attempt to promise a risk-free highway. Hauer's observations provide some measure of direction. It may be that minimum dimensions should be based on fundamentally human factors considerations.

Finally, where and how one chooses to establish minimum design dimensions also affects decisions about exceptions and design exception processes. Again, the answer to this question needs careful discussion. A design process that derived and codified dimensions that were as low/minimal as can be justified may satisfy some who argue that designers should always stay within published criteria. But others may not be comfortable with a process that has no 'out' or means of allowing an exception. Moreover, setting a very low bar for minimum criteria carries with it a responsibility for agencies and their design staff to be more knowledgeable and exercise judgment in ways that they currently do not typically do.

**Additional research is needed to set criteria based on the risk for the different contexts encountered on various projects.**

### 3.2.10 Finding 10

#### Nominal and Substantive Safety Differ in Meaningful Ways

For reasons noted by Hauer, a 'nominal safety' threshold approach is a necessary element of design policy. The legal framework in which the profession operates demands this. Owners and designers need to have firm, quantifiable and documentable thresholds against which their chosen design can be compared and defended as meeting the standard of care.

Unfortunately, the necessary concept of 'minimum' criteria or dimensions has taken on unintended meaning. In applying the AASHTO Policy designers have evolved to a 'mental model' was shown previously in Figure 3. A design that meets the minimum addresses any and all potential risks. Designs above the minimum will cost more with no quantifiable benefits. As Hauer has observed, what is characterized as minimums actually becomes maximums.

This mental model precludes a process that would seek an optimization of performance vs. implementation cost. Such optimization would reflect what is well known and documented about traffic operations and substantive safety, and that they will tend to vary over the range of reasonable design dimensions; that they will vary under different contexts. Given that implementation costs are clearly site-specific, strict adherence to minimum dimensions in every case (the nominal safety mental model) will not produce programmatically cost-effective designs.

***A highway design process that provides optimal results, requires design criteria to be applied based on research knowledge for substantive safety.***



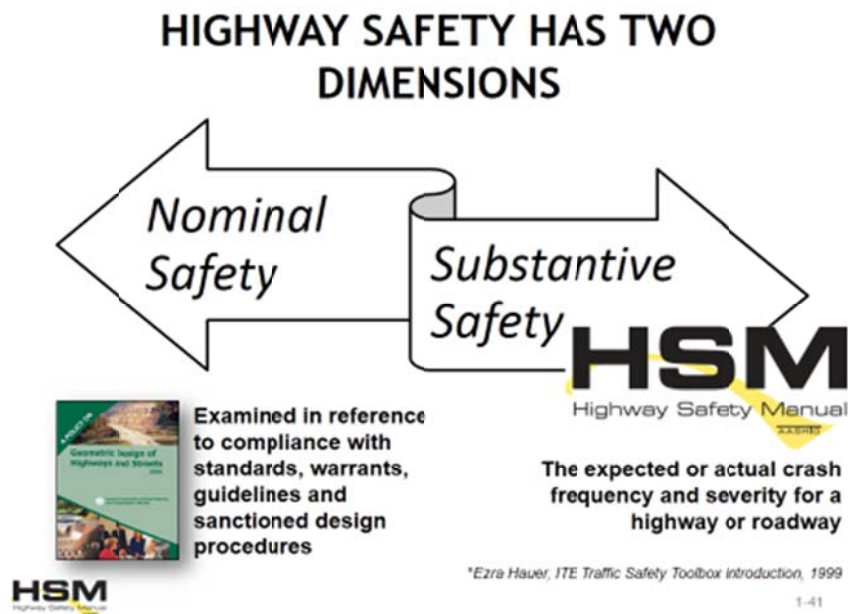

Figure 8. The Two Dimensions of Safety

Indeed, as demonstrated earlier, nominal safety models, equations and approaches are not nor were they ever related to substantive safety performance. As such one should simply not expect there to be a one-to-one relationship between a condition in which design criteria were substandard, and a history of crashes. For an existing road in which either reconstruction or 3R is being contemplated, a simple condition matrix describes what a designer may encounter (Figure 9).

		Is the designated project 'Nominally Safe'?	
		YES	NO
Is the designated project 'Substantively Safe'?	YES		
	NO		

*(Is the history of crashes along the project within a designated threshold of acceptability?)*

Figure 9. A Decision Matrix Based on the Two Dimensions of Safety

Depending on which quadrant the project falls, one should expect a fundamentally different approach to both defining the problem and proposing a solution.

***The design process, while requiring nominal safety thresholds, should be focused not on producing minimum designs, but rather on the optimization of substantive safety (and substantive performance) within an overall framework of implementation cost-effectiveness.***

### 3.2.11 Finding 11

AASHTO criteria should more completely reflect known interactive safety and operational effects of geometry

Research has established significant interactive effects of, for example, grade and alignment on speed; roadside design and alignment on safety performance; and speed change effects on safety performance. There is sufficient anecdotal evidence to suggest interactive effects worthy of investigation (e.g., the effect of grade and direction of grade on loop ramp operations for trucks). In the urban environment the combined effects of medians, access control and lane or roadway width are evident. Indeed, there is a striking disparity between the known importance of access control and management on both traffic operations as well safety performance, and the extent to which it is referenced in the development of other geometric elements, most notably urban cross section design. In the two-lane highway rural environment the primacy of roadside design in establishing safety performance is well understood, yet roadside design and both alignment and cross section are considered independent of each other.

***The formulation and application of design models, dimensions and approaches should to the extent possible directly incorporate meaningful interactive performance effects (speed, operations, substantive safety).***

### 3.2.12 Finding 12

Replace dimensional guidance with direct performance guidance where possible within the AASHTO Policy

Technology advances in traffic simulation models are now well established in practice. Their use should be explicitly acknowledged and referred to in the AASHTO Policy. Moreover, consideration should be given to their use with appropriate traffic data to replace current dimensional values in the Policy.

Consider, for example, Figure 10, which shows design guidance for ramp spacing and weaving as expressed in feet. These dimensions actually are based on both human factors knowledge and traffic operational analyses of freeway operations. This table could be replaced by performance outcome guidance (e.g., lane density in lane one, speed change between segments, speed differentials across lanes) with reference to appropriate simulation models for obtaining such performance measures, rather than citing physical dimensions. This concept is illustrated in the AASHTO Policy in Figure 10-2 which provides qualitative performance criteria rather than dimensions for access control near an interchange.

EN-EN or EX-EX		EX-EN		Turning Roadways		EN-EX (Weaving)			
Full Freeway		CDR or FDR		System Interchange		System to Service Interchange		Service to Service Interchange	
						Full Freeway		Full Freeway	
						CDR or FDR		CDR or FDR	
<b>Minimum Lengths Measured between Successive Ramp Terminals</b>									
300 m (1000 ft)	240 m (800 ft)	150 m (500 ft)	120 m (400 ft)	240 m (800 ft)	180 m (600 ft)	600 m (2000 ft)	480 m (1600 ft)	480 m (1600 ft)	300 m (1000 ft)
Notes: FDR—Freeway distributor road					EN—Entrance				
CDR—Collector distributor road					EX—Exit				

Figure 10. Dimensioned Minimum Ramp Terminal Spacing

Source: Figure 10-68 Recommended Minimum Ramp Terminal Spacing, AASHTO Green Book

Other research (design consistency module of the IHSDM) provides designers the ability to produce speed profiles along a 3D alignment for a range of vehicle types. Other examples of integrating simulation into design include turning lanes at intersections (based on, say, 95<sup>th</sup> percentile queues from simulation rather than fixed dimensions).

An interesting parallel to this recommended approach already exists, in the process associated with design decisions involving environmental criteria. Warrants for sound walls are based on land use types (residences, parks, schools, hospitals) and a noise level performance criteria – decibel levels at the receptor. The required design dimensions for the walls (locations, height) are obtained from noise modeling, not through specific look-up tables or published dimensions.

This recommendation has the benefit of requiring designers or those assisting them to compute a design dimension from a model or algorithm that expresses the performance intent. Designers thus must understand and apply the knowledge base behind the performance in order to dimension their plans.

**Physical dimensions are the means to the end, the end being some intended level of performance. The design process should 1) require use of best technology practices in confirming a design; and 2) replace reference to physical dimensions, with specifications for technical dynamic, performance-based approaches that will produce the appropriate dimensions for the specific project and context.**

### 3.2.13 Finding 13

*Advances in technology should be incorporated into the geometric design process*

Designers will always need to follow a basic ‘linear’ order of completing their work. They start with the cross section, then develop horizontal alignment, and next vertical alignment. This practical approach is unchanged by technology. However, the criteria designers are given and the manner in which they apply them have not yet been formulated or revised to take full advantages of the advances in technology. Both the formulation and application of AASHTO Policy criteria reflect the pre-computer age design process. For example, design policy provides look-up tables vs. functions or formulas. The former are an unnecessary simplification.

More importantly, in the pre-computer age the time and labor cost to complete all the technical work of roadway engineering was the controlling factor in the design process. Many technical approaches were established to

minimize the time and chances for error in calculating coordinate geometry (e.g., the use of parabolic vertical curves). An alignment once calculated and plotted required substantial time and effort to revise – both the engineering and drafting.

Computer aided engineering and design tools and methods have radically changed the profession of highway engineering in positive ways. Survey and mapping is much less time consuming than previously. The time to produce an alignment is fractions of what was required previously. Changes, new alternatives, and fundamentally different concepts can be produced in a matter of hours rather than weeks or months.



Figure 11. Drafting Machine. Source: *Technical Drawing, Seventh Edition, 1980*

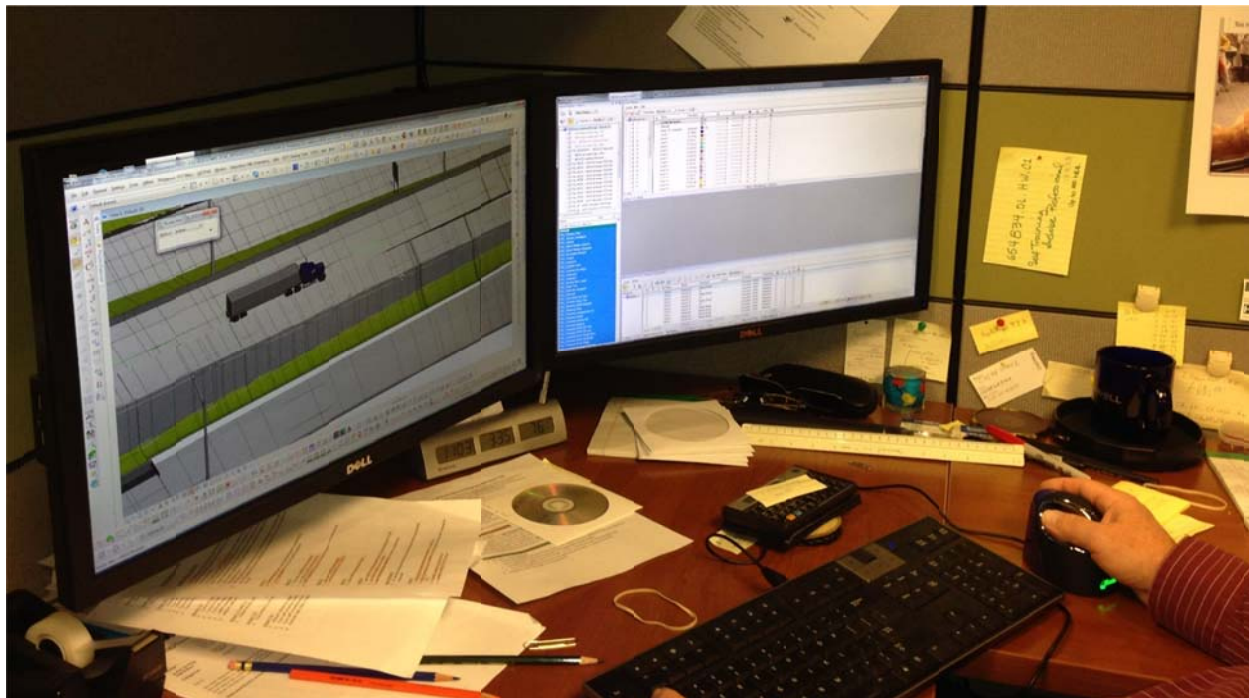

Figure 12. CAD Work Environment, 2015



Figure 13. ProjectWise: A Change in Construction. Source: [https://www.bentley.com/en/project-profiles/michigan-department-of-transportation\\_projectwise-a-change-in-construction](https://www.bentley.com/en/project-profiles/michigan-department-of-transportation_projectwise-a-change-in-construction)

Geometric design is three-dimensional. The ability to produce a 3D alignment and ‘drive’ it using simulation software is now easily done. The ability to produce sight distance profiles is similarly readily done. Human factors research has produced driver workload models.

Finally, advances in engineering approaches to traffic operations analysis and now substantive safety analysis have significantly improved our ability to predict and understand the performance of a design, under as many different scenarios of traffic and other factors as may be needed.

The current project development process includes traffic operations analysis, but mostly at the ‘front end.’ Most importantly, complete integration of dynamic operations analysis in an iterative manner is not routinely done. With respect to highway safety performance analysis, DOTs are just now beginning to learn the methods and approaches. Typical applications are in design exception evaluations, and to a limited extent alternatives analysis.

All the technology growth advantages offer the means for a dynamic, iterative design process as illustrated in Figure 14 and summarized here:

1. Project specific, context-sensitive design and performance criteria are established,
2. A design solution is developed in sequence (typical section, horizontal alignment, vertical alignment),
3. The dynamic performance of the solution is modeled as is the life cycle cost; with a cost-effectiveness index or optimization exercise completed,
4. Based on model results the geometry is revised,
5. Performance and cost are re-modeled and optimization re-computed until a consensus or satisfactory outcome is evident.

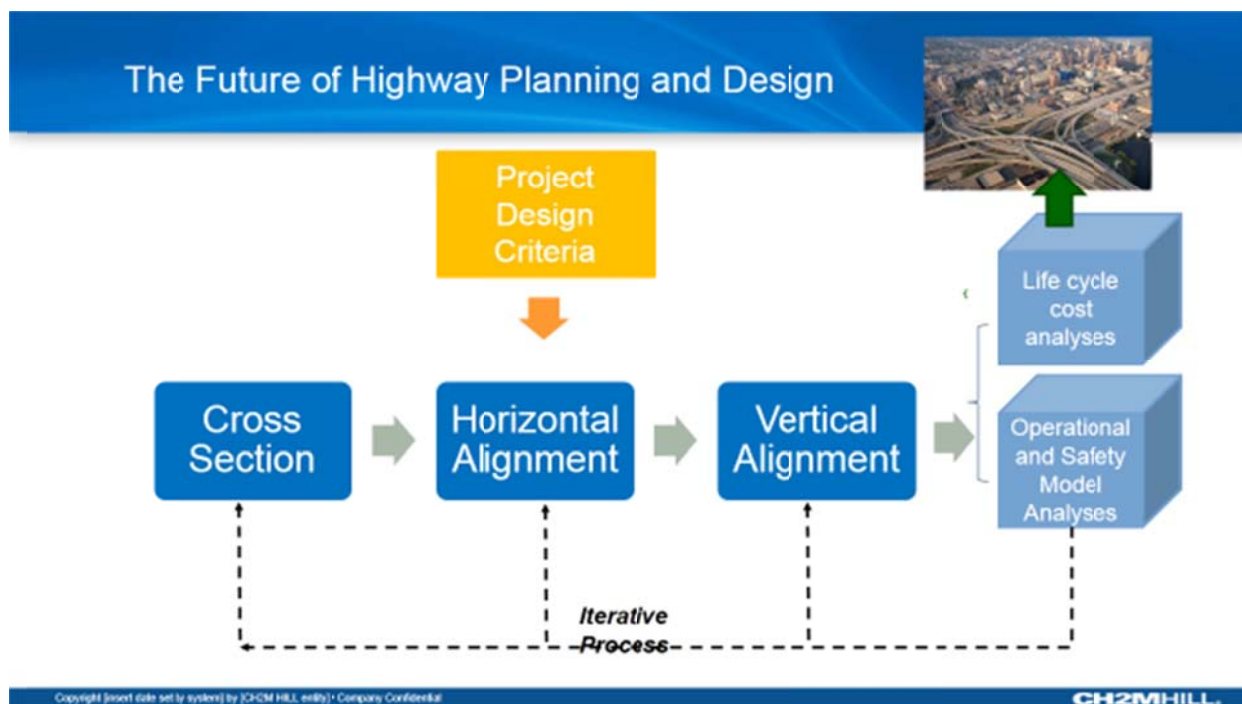

Figure 14. A Performance-based, Iterative Design Process

The effort, time and cost to re-design a project in such an iterative manner is no longer a limiting factor or constraint, given the advances in design technology. The more costly and complex the project (e.g., a multi-level system interchange) the more significant the potential benefits of such iteration.

The above process is ideally suited to a project development process in which stakeholder involvement occurs throughout alternatives and preliminary design. Note that this process was that envisioned (in more simple terms for 2-lane rural highways) by FHWA in the original concept behind their Interactive Highway Safety Design Model (IHSDM).

**Advances in design technology and performance-based analysis of geometric designs should be integrated within the design process in an iterative manner.**

### 3.2.14 Finding 14

The notion of ‘conservatism’ in policy and leadership in the highway engineering field needs a 180 degree shift

Much of design policy, including not only design models and dimensions, but attitudes about design and professional responsibilities, represents a legacy of the times up until the 1970s. In the very early days of road construction and through the interstate construction era, road designers made do with somewhat limited technical knowledge of operations and safety. The primary value to be met was speed. Funds for road construction were sufficient. The concept of ‘more is better’ in width, right-of-way, and footprint prevailed.

**Designer mindsets need to change. Being conservative should mean not reconstructing or adding cost to a project unless there is clear evidence of a performance improvement, using state-of-the-art methods for traffic operational or substantive safety analysis. ‘Upgrade to standards’ should be characterized for what it is – an administrative decision that often results in a wasteful expenditure of limited funds.**

### 3.2.15 Finding 15

Geometric design should be understood, taught, executed and communicated as iterative in nature with performance at the center of all iterations and optimizing

Following from all of the above, the geometric design process should clearly be understood as a dynamic and iterative one, as illustrated in Figure 13. The design itself should be viewed as the means to an end, the end being the expected or desired performance, as determined from the problem definition and scoping process.

At the university level as well as within DOTs, the teaching of highway engineering should not be limited to use of the design software and the contents of the Green Book. The engineering of a highway is fundamentally about the providing of transportation.

***Highway engineers should know traffic operational performance and how to predict it; and substantive safety performance.***

### 3.2.16 Finding 16

More explicitly incorporate maintenance and operation costs

The design and decision process in the U.S. has historically been driven primarily by initial implementation costs (right-of-way and construction costs). The financial sustainability of any agency's program is highly dependent on the maintenance and operating costs of their infrastructure. Implementation of agency asset management is the dominant emerging trend among forward thinking agencies.

There is a need to assemble and integrate the knowledge associated with maintenance and operating costs, particularly as pertaining to design decisions and trade-offs that are common in projects. For example, costs of roadside maintenance (mowing, ditch maintenance) vs. guardrail; signing, lighting and delineation; snow removal; retaining walls and structures vs. embankment; shoulder widths for maintenance and enforcement operations; raised vs. flush medians with plantings are all routine decisions that can have measurable maintenance costs.

***An iterative optimization process should include the ability to model or estimate annual maintenance and operating costs as a function of key design decisions – geometric and other – that are proven to influence such costs.***

## 3.3 References

1. American Association of State Highway and Transportation Officials, *A Policy on Geometric Design of Highways and Streets*, 2011.
2. American Association of State Highway and Transportation Officials, *A Guide for Achieving Flexibility in Highway Design*, 2004.
3. FHWA *Flexibility in Highway Design*, Federal Highway Administration, 1997.
4. American Association of State Highway and Transportation Officials, *Guidelines for Geometric Design of Very Low-Volume Local Roads ( $\leq 400$  ADT)*, 2001.
5. Joint AASHTO / FHWA Context Sensitive Solutions Strategic Planning Process, Summary Report, March 2007
6. Neuman, T., M. Schwartz, L. Clark, and J. Bednar., *A Guide to Best Practices for Achieving Context Sensitive Solution*, NCHRP Report 480, Transportation Research Board, 2002.
7. American Association of State Highway and Transportation Officials, *Highway Safety Manual*, 2010.
8. Transportation Research Board, *Highway Capacity Manual*, Transportation Research Board, 2010.
9. McGee, Sr., H. W., *Practical Highway Design Solutions*, NCHRP Synthesis 443, Transportation Research Board, 2013.

10. MoDOT *Practical Design Implementation Guide: Meeting Our Customer's Needs*, Missouri Department of Transportation (<http://www.modot.org/business/documents/PracticalDesignImplementation.pdf>)
11. Potts, I. B., D. W. Harwood, J. M. Hutton, C. A. Fees, K. M. Bauer, C. S. Kinzel, and R. J. Frazier, "Identification and Evaluation of the Cost-Effectiveness of Highway Design Features to Reduce Nonrecurrent Congestion," SHRP 2 Project L07 final report, MRIGlobal, 2013.
12. American Association of State Highway and Transportation Officials, *Geometric Design Guide for Resurfacing, Restoration, and Rehabilitation of Highways and Streets*, 1977.
13. Transportation Research Board, *Designing Safer Roads: Practices for Resurfacing, Restoration, and Rehabilitation Projects*, Special Report 214, Transportation Research Board, 1987.
14. Crump, E. T., ed., *Relationship Between Safety and Key Highway Features: A Synthesis of Prior Research*, State of the Art Report 6, Transportation Research Board, 1987.
15. Zegeer, C. V., and J. A. Deacon, "Effect of Lane Width, Shoulder Width, and Shoulder Type on Highway Safety," in Crump, E. T., ed., *Relationship Between Safety and Key Highway Features: A Synthesis of Prior Research*, State of the Art Report 6, Transportation Research Board, 1987.
16. Mak, K. K., "Effect of Bridge Width on Highway Safety," in Crump, E. T., ed., *Relationship Between Safety and Key Highway Features: A Synthesis of Prior Research*, State of the Art Report 6, Transportation Research Board, 1987.
17. Glennon, J. C., "Effect of Pavement/Shoulder Drop-Offs on Highway Safety," in Crump, E. T., ed., *Relationship Between Safety and Key Highway Features: A Synthesis of Prior Research*, State of the Art Report 6, Transportation Research Board, 1987.
18. Glennon, J. C., "Effect of Alignment on Highway Safety," in Crump, E. T., ed., *Relationship Between Safety and Key Highway Features: A Synthesis of Prior Research*, State of the Art Report 6, Transportation Research Board, 1987.
19. Glennon, J. C., "Effect of Sight Distance on Highway Safety," in Crump, E. T., ed., *Relationship Between Safety and Key Highway Features: A Synthesis of Prior Research*, State of the Art Report 6, Transportation Research Board, 1987.
20. Cleveland, D., "Effect of Resurfacing on Highway Safety," in Crump, E. T., ed., *Relationship Between Safety and Key Highway Features: A Synthesis of Prior Research*, State of the Art Report 6, Transportation Research Board, 1987.
21. Glauz, W. D., "Future Changes to the Vehicle Fleet: Effect on Highway Safety," in Crump, E. T., ed., *Relationship Between Safety and Key Highway Features: A Synthesis of Prior Research*, State of the Art Report 6, Transportation Research Board, 1987.
22. Harwood, D. W., E. R. Kohlman Rabbani, K. R. Richard, H. W. McGee, and G. L. Gittings, *Systemwide Impact of Safety and Traffic Operations Design Decision for 3R Projects*, NCHRP Report 486, Transportation Research Board, 2003.
23. Neuman, T. R. "Design Guidelines for Very Low-Volume Local Roads (< 400 ADT)," final report of NCHRP Project 20-7(75), CH2M HILL Chicago, Illinois: May 1999.
24. Ezra Hauer, "Safety in Geometric Design Standards", Professor (Emeritus), Department of Civil Engineering, University of Toronto, December 1999.





# 4 Guiding Principles for an Effective 21<sup>st</sup> Century Highway Design Process

There are certain guiding principles that should shape and define an effective process into the future. We characterize these guiding principles in three categories – the **fundamental bases** for road design, the **social and public policy framework** within which the process is conducted, and the **necessary attributes** of an effective process. These guiding principles are defined in the following subsections, and discussed in terms of their implications, opportunities for improvement, and potential barriers or conflicts.

## 4.1 Fundamental Bases for Roadway Design

The following subsections represent what should be the fundamental bases for design of roads, streets, and highways.

### 4.1.1 Geometric Design Solutions Should Address Objective, Quantitative Measures of Transportation Performance

Roadway design projects begin with a stated transportation problem. The purpose of geometric design is to provide the necessary three-dimensional framework for a road or highway to address the problem by providing the appropriate level of mobility and/or safety to the road users. Geometric design involves the application of tools, methods, dimensions, and criteria. **Dimensional and other design standards and criteria are a means to an end. The end is transportation performance, such performance to include mobility, accessibility, safety, and state-of-good repair.** Every phase, subprocess, methodology, or model developed and applied to highway design and highway design criteria should be objectively related to one or more measures of transportation performance.

The implications of this guiding principle are three fold. First, the mentality of the designer must shift from a dimensional-based approach to a performance-based approach. The traditional philosophical approach to design has been to treat minimum design criteria as adequate to produce an acceptable level of safety (1, 2). In traditional design practice, roads are implicitly characterized as being either acceptably safe, unsafe, and the application of minimum design criteria produces (supposedly) a safe highway. This traditional roadway designer's mental model is that of nominal safety (green line in Figure 15. According to this 'nominal safety' mental model, meeting the minimum criteria is all that is necessary or required of the designer. Indeed, designers are discouraged from providing *more* than the minimum values or dimensions, as doing so is presumed to increase the construction cost while producing no added value. The notion of safety as being a fixed attribute (roads are either safe or unsafe) precludes consideration of marginal differences in safety performance associated with marginally different design solutions. To summarize, the nominal safety mental model requires the designer to meet the minimum dimension, but does not reward or incentivize the designer from using more than the minimum dimension.

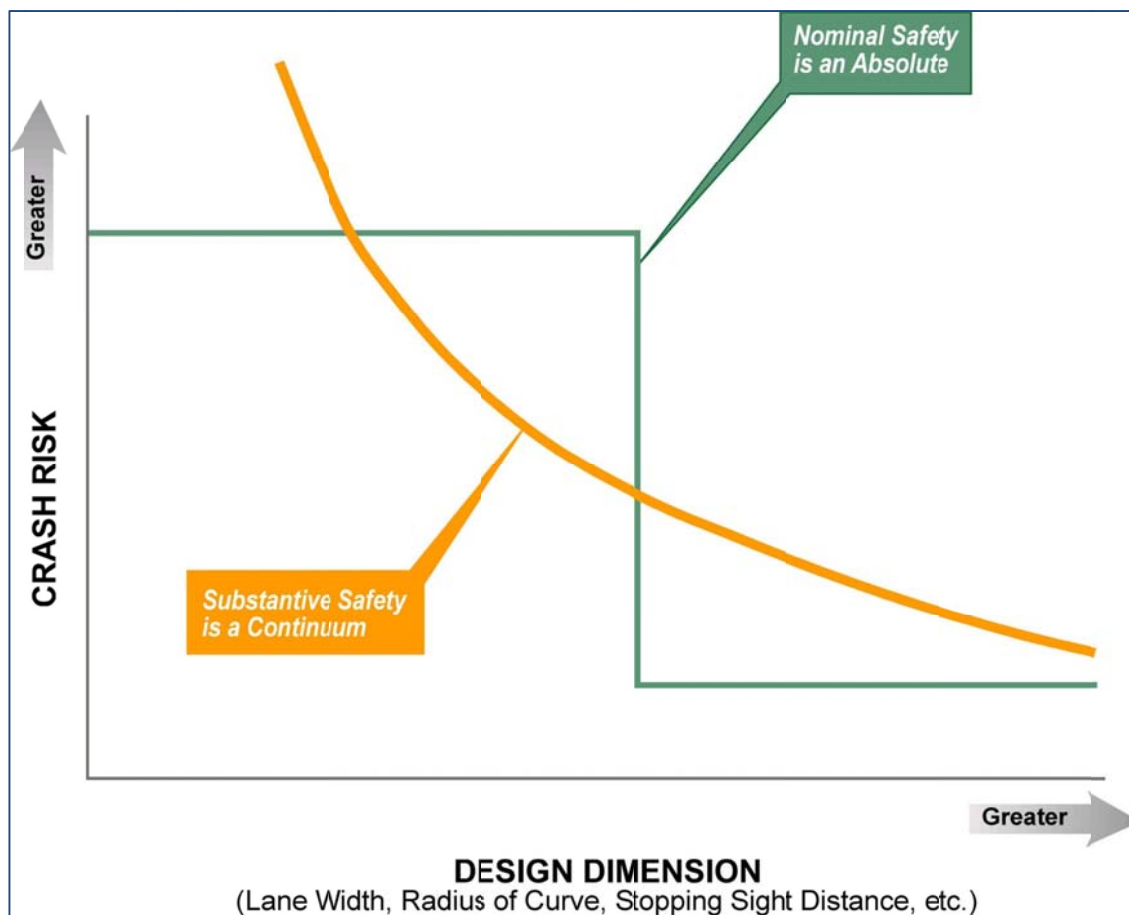

Figure 15. Two Mental Models for Safety in Design

The application of a green line model (nominal safety) may have been necessary in the past, when safety knowledge was generally lacking, but today, knowledge has advanced such that design for substantive safety has become not only feasible, but clearly desirable.

Safety, as understood by the risk of a serious crash, is not an absolute. In fact, the nominal safety model ignores the nuances of marginal differences in performance associated with design values or dimensions. Fambro (4) postulated that substantive safety is a continuum (the orange line in Figure 1) when discussing the expected differences in crash rates associated with stopping sight distance values that differed from the minimum criteria. Those familiar with the science of highway safety understand that the general relationship of the orange line is intuitively adaptable to other roadway elements and dimensions, including lane and shoulder widths, radius of curve, and grade.

The mental model of the green line (the minimum design dimension per criteria) bears a very limited relationship to either operational quality or safety performance for the dimensions associated with a geometric design feature (with perhaps the exception of structural vertical clearance). Moreover, where the minimum design criteria per American Association of State Highway and Transportation Officials (AASHTO) policies lie with respect to actual safety performance was neither known nor applied in the setting of many criteria in the past, with very few exceptions. This is because many of the geometric criteria were, given the state of knowledge at the time established without knowledge of safety performance, or based on relationships or models unrelated to safety performance.

Selecting an arbitrary green line for values associated with a geometric design element does not serve a geometric design process aimed at optimizing performance within a cost-effective design framework. Highway engineers and designers applying design criteria need to understand not just the criteria but the basis behind the criteria. The revised design process envisions that designers will need to approach their work with the performance-based

(orange) mental model rather than the dimensional-based mental model of design. Their design objective should be to not just apply a minimum criterion, but rather find the appropriate combination of criteria that provides optimal performance for an acceptable implementation cost, such combination and cost reflecting the specifics of the context.

The second of the three-fold implications of the guiding principle is that the geometric design process must be viewed as incorporating continuous change. The advances in our knowledge of safety and operational performance occur should be routinely input to the geometric design process. The design process should readily and seamlessly adapt to the changes in external circumstances (e.g., advances in vehicle technology and changes in the vehicle fleet, social policies, and priorities regarding funding of transportation infrastructure). Each project does not exist in a vacuum, but rather contributes to the local, regional, and statewide transportation network. The design process must be adaptable to the evolution of societal investment decisions on highways and indeed all transportation infrastructure.

The third implication combines the first two. The design process must transition to one that directs the optimization of a solution (in performance-based terms) within the context of resources allocated to the project. This may be viewed as a cost-effectiveness approach, but an important consideration is that resource allocation should be considered in a life-cycle sense. In other words, the design process should directly consider not only the initial capital cost of the project, but also the long-term operational and maintenance costs of the implemented solution. Such costs impose permanent financial liabilities on the owning agency, and as such produce long-lasting constraints on the agency's ability to maintain the performance of its system. Limitations in resources provided to the agency must influence the designation or determination of a cost-effective design dimension or solution. This is the essence of recent project development approaches taken by agencies such as the Washington State Department of Transportation (DOT) and the Missouri DOT.

With respect to geometric design criteria as promulgated by AASHTO, there are significant opportunities to update and revise subprocesses and geometric design models to make them more performance based. Table 7 summarizes the results of an analysis of geometric design criteria in the 2011 AASHTO Policy on Geometric Design of Highways and Streets (4), referred to as the 'Green Book.' Although some design criteria have been formulated using transportation performance inputs, many others have not. Moreover, basic models that are theoretically performance based are either outdated, overly simplistic, or unproven in their relationship to actual performance. A truly performance-based design process cannot be achieved without a comprehensive review and overhaul of many of AASHTO's geometric design approaches and models that have been unchanged for more than 70 years. Section 3 of this report provides an overview of potential new approaches to the development of geometric design criteria.

#### 4.1.2 The Geometric Design Process Should Explicitly Address All Potential, Legal Road Users

Roads and road corridors are now understood as serving transportation needs of not only motor-vehicle drivers and passengers (including motorcycles), but also cyclists and pedestrians. The geometric design process should direct the evaluation of the need to provide transportation service for each user type, and the spatial and operational design requirements to serve all users.

Addressing all legal road users does not merely mean providing space for them within the roadway or right-of-way. It also means designing a corridor in recognition of the unique risks and performance needs of the users. In addressing all legal road users, the design process must provide a means or process for prioritizing what may be conflicting operational needs. Not all roads serve or should serve all road users to the same extent. ***The context should define what types of users should be expected or explicitly addressed, and the relative importance of each user type.*** An important aspect of the recommended geometric design process is the recognition of what user types should be included under which contexts. For example, agencies may explicitly choose to exclude consideration of pedestrians and bicycles within certain corridors such as controlled access facilities. Another

example may be the design of a parkway for which trucks are prohibited. Finally, pedestrian-only corridors or transit-only corridors are solutions applicable to many urban contexts.

There are many implications of this guiding principle. Perhaps the most important is the clear difference in providing for transportation performance – both safety and mobility -- for vulnerable users versus those traveling in motor vehicles. Historically, AASHTO geometric design approaches and criteria have evolved based on meeting the user needs of those traveling in motor vehicles, with the primary transportation value being vehicular mobility. Providing for performance in motor vehicle mobility historically translated to designing roads for as high an operating speed as was reasonable given the context. Indeed, highway engineers have learned to equate design speed with design quality (the higher the better). In a multi-modal corridor serving not only motor vehicles but also pedestrians and bicyclists, higher motor vehicle speeds may be incompatible with the mobility and safety needs of such vulnerable users. A future geometric design process must provide a direct means for design engineers to produce a high-quality design based on whatever is an appropriate speed given the context and composition of the traveling public. In some cases, this may mean taking explicit actions to produce lower, not higher, vehicle speeds.

Another implication (linked to the above guiding principle) is the difference in operating performance associated with the wide range of legal vehicles on the road network. Differences in operations and safety performance associated with passenger cars versus larger, heavy vehicles (single unit trucks, tractor-semi-trailers, buses) is well documented in the literature (5, 6). One important challenge of a revised process is the determination of how to best serve the needs of the full range of vehicle types that differ so much in their individual performance characteristics. This may mean, for example, using a vehicle other than a passenger car as the basis for horizontal alignment for some contexts. Such an approach is really not new. For example, the operational bases for roadside barrier design are routinely changed as the vehicle fleet changes, with varying combinations of vehicle type, size, and weight applied first in the NCHRP Report 350 design guidelines (7), and now with the MASH design basis for barriers (7).

### 4.1.3 The Geometric Design Process Should Integrate Operational Solutions with Geometric Elements

Solutions to performance problems include features or concepts other than roadway geometry. Operational solutions include traffic control, signing and warning devices, traveler information using intelligent transportation system (ITS), and real-time demand responsive systems to help regulate speed and reallocate signal priorities. Operational solutions are now evolving that incorporate in-vehicle technology. The maturation of ITS and the ability to operate a corridor or network in real time offers benefits to highway agency customers. It also offers opportunities to adjust approaches to geometric design.

Consider, for example, the traditional rationale and requirements for full-width shoulders on urban freeways, shoulders provide space for emergencies, enforcement and maintenance, all of which drive the width dimensions in AASHTO Policies. But with the ability to monitor traffic continuously via ITS systems, and apply automated enforcement where enabling legislation exists, the need for full shoulders on some corridors and in some contexts may be greatly lessened. Moreover, an optimal design solution may be the reallocation of the space previously allocated for full shoulders to travel lanes.

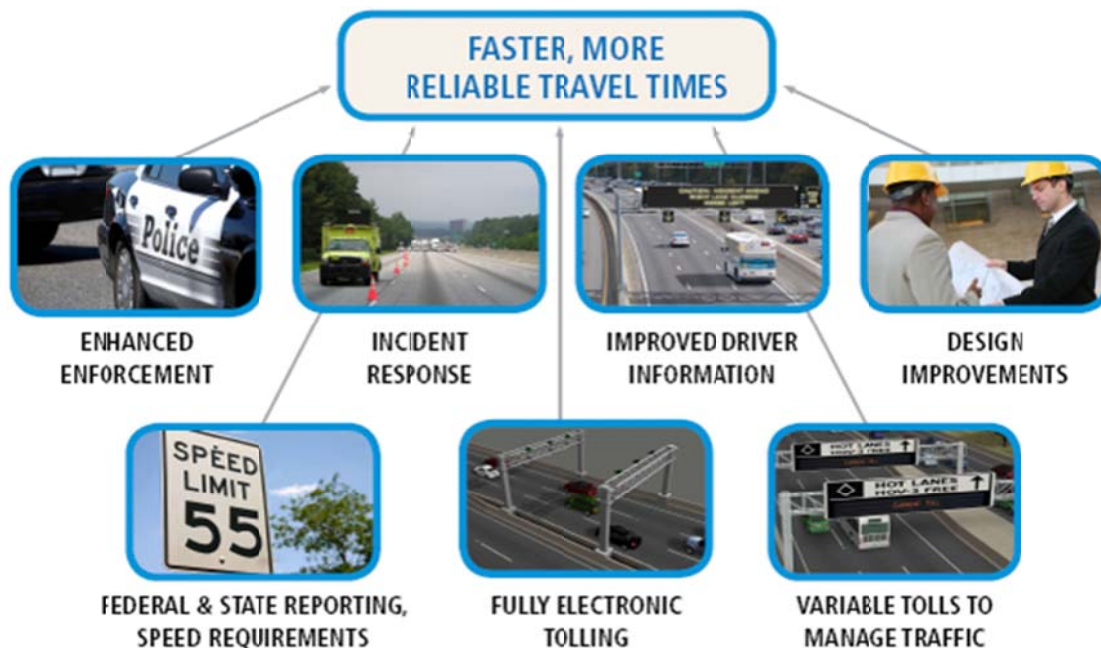

Figure 16. Value Proposition: Reliable Travel Time

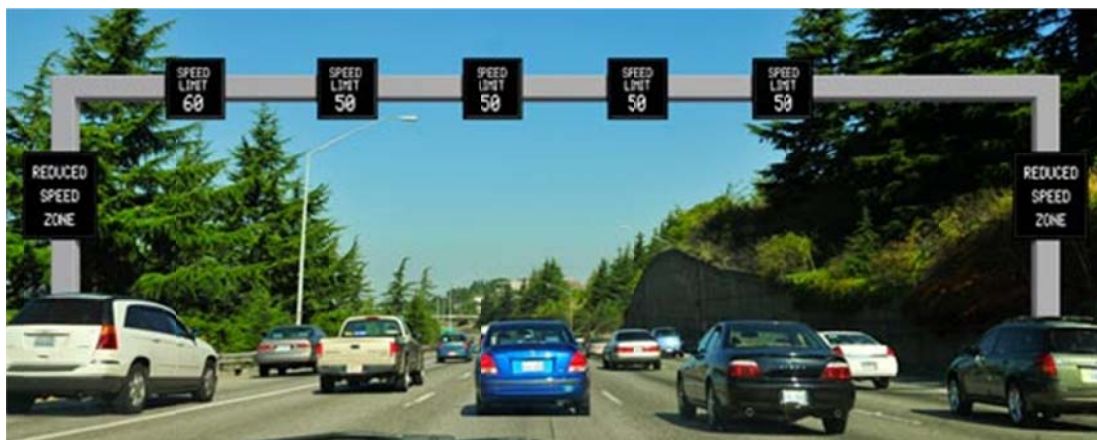

Figure 17. Smarter Highways variable speed limits

Source: <httpwww.wsdot.wa.govsmarterhighwaysvsl.htm>

The qualitative tradeoffs associated with an urban freeway cross section with full shoulders versus one without full shoulders that incorporates ITS technologies are further illustrated in Figure 18. These qualitative tradeoffs will vary in magnitude and relative importance; they will or should be quantifiable in any geometric design context. The point of this comparison and qualitative analysis is to demonstrate that incorporation of operational solutions or features can and should be part of the geometric design process and decision-making process, rather than a separate or after-the-fact process

	Freeway Cross Section Alternatives*			
	3 Lanes plus Full Outside Shoulder	4 Lanes with Full Outside Shoulder	4 Lanes with No or Minimal Shoulder	4 Lanes with No or Minimal Shoulder and ITS
Mobility (Capacity)				
Safety Performance				
Maintenance of Roadway Cost				
Maintenance of Roadside Cost				
Operation (Incident Management)				
Snow Removal Cost				
Law Enforcement				
Cost to Construct				

\*Colors represent qualitative rating, with green being best, yellow next, and red worst for a given attribute

Figure 18. Qualitative Demonstration of Tradeoffs for Cross Section Alternatives Incorporating Varying Lane and Shoulder Width Strategies and ITS

Under the current geometric design process, the conversion of shoulders to travel lanes, or their use during certain time periods such as peak periods (e.g., on Interstate (I)-66 in Northern Virginia), or for transit vehicles as is shown in Figure 19, require design exceptions. In the context of resource limitations, highway agencies are employing ITS solutions to achieve mobility and safety performance goals. The future geometric design process should enable and indeed encourage an agency to take full advantage of operational solutions to adjust their approaches to geometric design decisions; and the design process should support such approaches rather than treat them as exceptions.



Figure 19. Transit Service Operation on Freeway Shoulders in Minneapolis

Similarly, a run-off-road safety problem at a horizontal curve may be addressed by curve flattening, shoulder widening, or a combination of the two; but it also may be addressed by advanced speed warning or special high-friction pavement, particularly if the crash history suggests wet or icy pavement as a contributing factor. If such less costly solutions reasonably address the stated problem, the design process should lead to their acceptance. Such solutions should be considered part of the geometric design, not as an alternative to geometric design. The geometric design process should be more broadly defined as a design and operational solutions process.

Finally, the preceding discussion is intended to be illustrative. Fundamental to a successful process is the ability to quantify the benefits and costs of incorporating (or not incorporating) ITS solutions as part of the alternatives evaluation process.

#### 4.1.4 The Design Process is Forward Looking

Road infrastructure is designed and constructed to accommodate the future transportation needs. Right-of-way purchased for transportation is removed from other productive uses. Well-constructed and maintained roads and bridges should last 75 years or more. Right-of-way acquired may be the maximum available into the future, depending on how the adjacent land develops and matures over time. The value and utility of right-of-way will last for 100 years or more.

This guiding principle is not new, but its implications are often overlooked. A forward-looking process contains built-in uncertainty. Actual traffic will differ from travel demand forecasts, unforeseen changes in the context will occur, and roads designed using models will not always perform as expected or intended. Such uncertainty cannot be overcome with additional data, greater investment in technology, or more detail in the engineering.



The amount of uncertainty and the implications of different futures emerging will vary widely based on the local and regional context. Major portions of the United States have experienced little or no growth for 30 years or more. The land use in many urban areas is fully built out and stable. Also, certain project types are inherently more uncertain in their outcomes than others.

- New roads on new alignment are clearly the most difficult to forecast the future. New roads will generally affect land development patterns in very significant ways. They will change commuting, freight movement, and other travel patterns. Major new roads may significantly spur regional development in ways that influence the road network beyond the project itself. Safety prediction and operational models based on research elsewhere may be applicable to new roads, but the extent to which actual outcomes mirror modeled ones is inherently uncertain.
- Reconfigured and reconstructed roads may produce some level of uncertainty in future traffic patterns if they include substantial increased capacity. Such projects may result in intensification of abutting land use, and regional travel pattern shifts. However, reconfigured and reconstructed roads will generally produce more predictable and less severe changes in traffic patterns than new roads on new alignment.
- Reconstructed roads in their current configuration and 3R projects will generally produce little measurable change in patterns or volume of traffic. Post-construction outcomes will be more predictable from a safety and operational perspective.

A significant design process challenge regarding future uncertainty is the conflict between the typical nominal design year for infrastructure, and the useful physical life of such infrastructure. Highway projects are sized based on forecast travel demands, which reflect forecasts of land use, local and regional socioeconomic changes, evolution in social trends related to transportation, and national and local policies.

Travel demand forecasts typically reflect a nominal 30-year timeframe from initial studies, which represents a consensus maximum ability to forecast the cumulative effects of the above factors on travel demand. Complex and/or substantial projects can take up to 10 years or longer from the original planning phases to construction, thus frequently resulting in a project sized to meet as little as a 20-year future post-construction time. This contrasts with the useful life of newly constructed pavement, bridges, and other infrastructure, which is at a minimum of 50 years, and depending on many factors may be as great as 100 years. Indeed, much strategic research is being conducted by AASHTO and the Federal Highway Administration (FHWA) on long-lasting pavements and bridges (9). This strong emphasis in future infrastructure policy would further widen the gap between a nominal design year under current processes, and the actual physical useful life of road infrastructure. Based on the complexity of the project, a risk assessment of the forecast traffic should be conducted.

***The geometric design process must address and reconcile differences in the timeframes associated with the ability to forecast future demands and needs and the intent of infrastructure investments to be more long-lasting. This is especially true for new construction and reconstruction projects.***

#### 4.1.5 The Design Process Must Be Context Sensitive to the Extent Possible

The experience of designers working with stakeholders in the Context Sensitive Solutions environment was captured in NCHRP Report 480 (3). Context as broadly defined varies widely. Every project is unique. ***The current AASHTO context framework comprised of area type as defined by urban and rural; three levels of functional classification; and three levels of terrain is insufficient to fully capture all relevant context factors.*** The geometric design process needs a more robust set of context definers, and the design process should support or direct design decisions, dimensions, and choices consistent with the defined context.

In particular, context definers are needed that differentiate how the full range of legal users should be prioritized. Research supports the intuitive notion that the type and intensity of land use strongly influences the propensity for pedestrian activity. Explicit land use policies and ordinances employed by cities are now common in promoting walkable or pedestrian-friendly environments (10, 11). The road design process must encompass such land use

policies and actions. Potential new approaches to a more robust context framework are presented in the following subsection.

#### 4.1.6 The Design Process Must Be Financially Sustainable at Both the Program and Project Level

The design process should recognize both the initial and long-term financial implications of the constructed solution. Initial capital costs represent one aspect; agencies must commit resources for ongoing maintenance and operational costs of the project as well. The design process should be sufficiently flexible such that the agency can execute it over time under a range of available resources. The typical challenges as related to the sustainability of the highway trust fund is demonstrated in the Figure 20, highlighting a short fall in highway trust fund revenues and evaluation of policy level solutions to address the issues.

**Table 1.—Estimates of Revenue and Outlays for the Highway Trust Fund  
Fiscal Years 2014-2025  
[billions of dollars]**

	2014	2015	2016	2017	2018	2019	2020	2021	2022	2023	2024	2025
<b>Highway Account</b>												
Start-of-Year Balance	4	11	2	a	a	a	a	a	a	a	a	a
Revenues & Interest <sup>b</sup>	34	34	35	35	35	35	35	35	35	35	34	34
Intragovernmental Transfers <sup>c</sup>	18	0	0	0	0	0	0	0	0	0	0	0
Outlays	45	44	45	45	46	46	47	48	48	49	50	50
End of Year Balance**	11	2	a	a	a	a	a	a	a	a	a	a
<b>Transit Account</b>												
Start-of-Year Balance	2	3	1	a	a	a	a	a	a	a	a	a
Revenues and Interest <sup>b</sup>	5	5	5	5	5	5	5	5	5	5	5	4
Intragovernmental Transfers <sup>c</sup>	4	0	0	0	0	0	0	0	0	0	0	0
Outlays <sup>d</sup>	8	8	8	8	8	9	9	9	10	10	9	10
End-of-Year Balance	3	1	a	a	a	a	a	a	a	a	a	a
<b>Memorandum</b>												
<b>Cumulative Shortfall<sup>e</sup></b>												
Highway Account	n.a.	n.a.	-8	-19	-29	-41	-52	-65	-79	-93	-108	-125
Transit Account	n.a.	n.a.	-3	-6	-9	-13	-17	-22	-27	-32	-37	-43

Notes: Details may not add to totals because of rounding.  
n.a. = not applicable.

a. Beginning in fiscal year 2015, CBO projects, revenues credited to the highway and transit accounts of the Highway Trust Fund will be insufficient to meet the fund's obligations. Under current law, the trust fund cannot incur negative balances, nor is it permitted to borrow to cover unmet obligations presented to the fund. Under the Balanced Budget and Emergency Deficit Control Act of 1985, however, CBO's baseline for highway and transit spending must incorporate the assumption that obligations incurred by the Highway Trust Fund will be paid in full. As a result, the cumulative shortfalls shown here are estimated on the basis of spending that would occur if obligations from the fund each year were equal to the obligation limitations enacted for 2014, adjusted for projected inflation. To meet obligations as they come due, the Department of Transportation estimates, the highway account must maintain a cash balance of at least \$4 billion and the transit account must maintain a balance of at least \$1 billion.

b. Some of the taxes that are credited to the Highway Trust Fund are scheduled to expire on September 30, 2016, among them the taxes on certain heavy vehicles and tires and all but 4.3 cents of the federal tax on motor fuels. However, under the rules governing baseline projections, these estimates reflect the assumption that all of the expiring taxes credited to the fund continue to be collected.

c. Sections 402(i) and 40251 of the Moving Ahead for Progress in the 21st Century Act (Public Law 112-140) and section 2002 of the Highway and Transportation Funding Act of 2014 (Public Law 113-159) required certain intergovernmental transfers, mostly from the general fund of the Treasury, to the Highway Trust Fund. CBO's baseline does not reflect an assumption that additional transfers from the general fund would occur.

d. Outlays include amounts transferred between the highway and transit accounts. CBO estimates that those amounts would total about \$1 billion annually.

Figure 20. Sustainability of Highway Trust Fund

Source:

Joint Committee on Taxation, *Long-Term Financing of the Highway Trust Fund*, (JCX-92-15), June 15, 2015.

A practical design approach is one that delivers value within the budgetary limitations of the agency. Each project is not independent of other projects completed by the agency. Design decisions that impose immediate and long-term costs will influence the ability for other projects to be performed either at all, or in an optimal manner. As an example if 90% of the identified problem could be solved for \$1 million and 100% will require \$10 million, the less than perfect solution should be considered.

## 4.2 The Design Process Must Be Conducted within the Prevailing Social and Public Policy Framework

Highway design and construction were considered a core function of government. Construction funds were generated through taxes, fees, and appropriations at the federal and state levels. The legal system provided the principal of Eminent Domain, enabling the acquisition of necessary right-of-way for construction.

Highway engineering professionals operated within the governmental framework. When the highway design profession came into being, and road design and construction emerged in the early 20<sup>th</sup> century, the road design process was purely technical. Highway engineers developed technical tools, methods, and models independent of external inputs. The process was wholly a technical, internal process. The technical disciplines included geometric design, pavements and materials, bridge design, geotechnical engineering, hydrology and drainage, and construction. Accountability for finished projects was through budget and schedule completion. The work of professional engineers was considered beyond questioning, and their recommendations or requirements were generally unchallenged.

As roads were built, the political landscape changed in the United States, and important societal issues and external pressures emerged. The influence and interaction with nonprofessional stakeholders began to influence project development. The progression of questioning and input by these stakeholders led to the passing of the National Environmental Policy Act (NEPA) and other subsequent legislation.

The road design process is no longer an independent, wholly technical engineering process. Projects that involve public allocation of resources, acquisition and use of public rights-of-way, and provide a core value or service to the general public are considered to be political projects. ***A guiding principle behind the 21<sup>st</sup> Century geometric design process is the explicit recognition of a social or societal, public policy framework that influences and directs the process and its execution.***

### 4.2.1 Accountability and Responsibility

Every project is the responsibility of an owning agency, which is typically a unit of state or local government. All decisions regarding every project must be made or endorsed by the entity that is given the responsibility, including the funds and other resources, for design, construction, operations, and long-term maintenance. The accountability for the outcome of a project rests with the policymakers who direct or manages the transportation agency. Furthermore, accountability must reflect objective measures of performance (safety, mobility and accessibility, and lasting functional value), resource allocation (funds allocated for construction and maintenance), and meeting expectations regarding delivery (timing and schedule, direct and indirect effects of construction on others). Such accountability measures apply at the programmatic and individual project levels.

At the individual project level, the notion of accountability rests with the responsibility of knowledgeable, properly trained, and professionally licensed design professionals to undertake or oversee the project. The process can be made more rigorous; and it can employ more technical models, methods, or analytical procedures. But the geometric design process will always involve some measure of uncertainty, require assumptions where data are incomplete or unavailable, and require judgments that must reside with those fully trained in all aspects of the road design process.

External stakeholder involvement in highway design project development emerged with the context-sensitive solutions/design initiatives in the 1990s. The value and necessity of input from external stakeholders is unquestioned; it is considered essential. However, input and involvement should not be confused with ultimate responsibility and accountability. Highway engineering and design decision-making are and should continue to be the responsibilities of professional engineers and other licensed or similarly qualified professionals who are engaged on behalf of the owning agency.

In many countries, and now in certain states within the United States, there are roads or networks for which the design, construction, and operation and maintenance (O&M) may be outsourced to private entities for

considerable lengths of time. Privatization does not eliminate the public nature of the infrastructure, it merely changes the manner in which the transportation service is delivered. The ultimate public owning agency communicates its values and establishes accountability through the contracting terms of the privatized facility and the extent to which the owning agency monitors and enforces its contracts.

## 4.2.2 Legal Framework

There are five distinct aspects of the legal framework in the United States that affect the road design process. These are tort laws and civil actions involving professionals and agencies, laws and regulations associated with licensing and enforcement of traffic laws, the environmental and social regulatory process at the federal and state levels, the regulation of motor vehicle manufacturing and sales, and governmental policies that direct resources and their use toward transportation facilities.

### 4.2.2.1 Tort Laws and Professional Liability

The legal framework includes the establishment of laws and procedures for holding professional engineers accountable for their design, construction, and maintenance efforts. The acceptance of professional liability for design errors or omissions is a centerpiece of the design process. All states require that design plans be sealed by professional engineers licensed in the state in which the project is to be constructed. An important element of the prevailing tort law framework is the liability associated with types of actions that engineers and agencies undertake. Generally, ***actions involving design decisions are considered discretionary in nature, and as such are typically immune from tort actions***, as long as the professional engineer and agency apply current practices, implement agency policies, avoid errors or omissions in their work, demonstrate appropriate professional judgment, and fully document their work (12, 13).

Professional engineers must employ a process that reflects best practices of the profession. Such best practices are science-based and transparently published in peer reviewed research and other reports. Best practices change over time as the knowledge base and technology improvements come into being. Agencies must commit in an ongoing manner, at a minimum, to monitor advances in knowledge; and ideally sponsor and conduct research to continuously improve the knowledge base and resulting design process.

The road design process is sufficiently complex, specifically with respect to the context of the road, such that a simple, formulaic, or rote design process is not possible. Professional engineers cannot hide behind criteria or dimensions, but rather must exercise judgment and be accountable for those judgments.

#### 4.2.2.1.1 Design Exceptions

The concept of design exceptions, which evolved in response to the combination of loss of sovereign immunity in the 1950s and difficulties in applying published design criteria to every project, is a special aspect of designer discretion and agency risk. Design exceptions have become integral to the geometric design process. In many project types they are routinely applied.

Design exceptions involve the use of a dimension that is outside the applicable dimension for the context as understood by functional classification, area type, and design speed (14). The need for a design exception is intended for special circumstances such as environmental conflicts, terrain, or other features that may preclude application of applicable geometric design criteria. The purpose of a design exception process is to document where a designer could not or need not apply the relevant dimension. By documenting the exception the designer avoids the possibility of the design being interpreted as an error or misapplication of design standards, a situation which could arise in the future should a crash occur that could be linked to the design feature in question. Such documentation would demonstrate the professional engineer's unique dilemma, the design choices considered, and effects of such choices, and the engineer's judgment as to the appropriate solution for the context. (Absent such specific documentation, the only evidence in an adversarial tort setting of an agency's design decisions are the contents of the road plans. Should the plans include a design dimension outside that of the applicable design policy, a judge or jury could reasonably interpret the plans as containing an error, in which case a potential finding of negligence may result.)

A basic problem with highway designer decision-making regarding design exceptions is the presumptive linkage between the criteria and safety performance (see Figure 1). When a design exception is considered or applied, the designer bears the burden of proving that the exception will not adversely affect the safety performance of the road; or that whatever compromise in safety occurs is necessitated by an unavoidable impact. Designers also are expected to mitigate the potential adverse consequences as well (14). Risk management policies employed by most agencies stress that design exceptions should not be justified based solely on construction cost savings, but rather on other quantifiable effects such as right-of-way or environmental consequences.

Design exceptions are generally recognized as increasing tort liability risk to agencies, increasing the time and cost to reach a decision and producing less than optimal design outcomes. Some designers believe that design exceptions are indicative of failure, or that they will produce an inherently inferior design, or the agency or even individual will be open to a tort lawsuit should a crash occur, even if documentation is produced. Risk management processes that are employed to review, approve (or not approve), and document design exceptions can increase project development time and cost. Design records maintenance for future reference also is vital for an agency, creating an additional administrative cost.

The design process did not always require design exceptions. They evolved in response to the voluntary ceding of sovereign immunity by states, with the resulting need to provide defense against tort suits. Research has demonstrated both the frequency and routine application of certain design exceptions (15), and the lack of widespread adverse safety performance consequences when these are appropriately applied (16).

***A geometric design process that routinely incorporates exceptions to what are supposed to be appropriate best practices, dimensions, or standards is suboptimal.*** Such a process over emphasizes the physical dimensions of the roadway, which are not the end but the means to the end, which is performance. Where design exceptions are routinely considered and granted, this demonstrates either inappropriate geometric standards, lack of creativity by the designer, or insufficient flexibility in the application of the standards. For example, shoulder widths on freeways, stopping sight distance (or length of vertical curve) on two-lane roads, and lane widths are often designed as exceptions on reconstruction projects (15). Despite the firm, stated minimum 12-foot lane widths for freeway lanes per current AASHTO Policy and FHWA Interstate Standards, less than 12-foot lanes are so prevalent that there was sufficient data in recent research on safety performance of freeways and interchanges to enable establishment of the relative crash risk of lane widths less than 12 feet (17).

Agency designers and approvers involved with such projects demonstrate an implicit understanding of the lack of risk (or lack of cost-effectiveness in applying the full criteria), yet the design criteria remain unchanged, and the design process requires such treatments as exceptions.

A design process that treats published dimensions as firmly associated with some level of safety deemed appropriate (and that invites the inference that an exception will not provide that appropriate level of safety) and ignores the reality of safety performance related to design elements and context. It needlessly increases project development time and cost, and unnecessarily injects a measure of tort liability risk (associated with incomplete documentation, or documentation lost or not retained when needed in future years).

***The geometric design process should produce an outcome that is optimal given the context, which is the desired expectation, and as such should not need to be labeled or considered an exception.*** The process by which the geometric dimensions and elements are obtained and included in the design should suffice to establish the basis for the design. If done properly and documented completely, an ideal geometric design process should not require an exception process, but rather a complete and thorough optimization analysis and documentation.

#### **4.2.2.1.2 Ministerial and Mandatory Duties of Highway Agencies**

Design decisions are discretionary in nature and generally immune from tort actions when performed and documented properly. Maintenance functions, however, are typically considered ministerial or mandatory, and present a different risk profile to transportation agencies, which are at risk of successful tort actions if they fail to maintain and operate their road systems in a reasonable manner, consistent with their agency's policies.

The importance of understanding this aspect of the legal framework is twofold. First, it must be assumed that the tort law framework will continue, as it is imbedded in United States laws and legal traditions. Second, as many agencies transition to greater maintenance functions and fewer reconstruction or new construction activities, the importance of direct consideration of the potential impacts of design decisions on maintenance, and vice versa, becomes that much greater. Geometric design decisions can have a meaningful impact (plus or minus) on the difficulties and costs of maintenance. The design process and designers should understand and account for these impacts and not consider them merely the business of others within the agency who will be engaged only after design and construction is completed. There is no comparable exceptions process with respect to maintenance activities. Agencies may adjust certain maintenance policies to reflect budget constraints, but many activities must be undertaken regardless of costs or consequences.

#### 4.2.2.2 Driver Licensing and Traffic Law Enforcement

Other aspects of the legal framework include laws and regulations associated with licensing of drivers, passage and enforcement of traffic laws, and definitions and restrictions on legally operable vehicles. The engineering profession must assume that driving will continue to be a highly regulated privilege in which drivers are repeatedly tested, licenses issued, suspended, and revoked based on driver behavior and physical capabilities. Roadway designs should consider the needs of traffic enforcement. Similarly, regulations and laws at the federal level governing the characteristics of motor vehicles – their performance in crashes and dimensions is a key element of concern. The legal framework associated with licensing and operation of vehicles allows the design profession to make reasonable assumptions for the purposes of designing and operating infrastructure.

The onset of what is referred to as driverless vehicles is acknowledged. How this new technology will influence geometric design remains to be seen. It seems clear that the road system will continue to be driven with human input for many years to come. Some corridors or special roads may, over time, be fully automated but what is more likely is the evolution of a vehicle fleet that is highly interactive with roadway infrastructure to limit or minimize the adverse effects of driver errors. To the extent that future driverless technology will include some component of roadway infrastructure (sensing), the vast size of the United States highway system suggests complete implementation is decades away at best.

The increase in bicycle usage and promotion of walking as a transportation mode for which design is necessary creates some challenges. There are typically no legal restrictions on bicycle riding in public roadways, by age or capability. There also are no limitations or legal requirements on walking speed or capability. Indeed, the Americans with Disabilities Act (ADA) legally sets requirements for accommodation of pedestrians and in particular disabled and blind pedestrians. In both instances the geometric design process may require tailoring to the unique demographics of the area in which a project exists.

#### 4.2.2.3 Environmental Regulations and Laws

A third aspect of the legal framework is in the environmental regulatory process that exists at the federal and state levels. Laws and regulations governing the processes by which environmental issues are disclosed, studied, and influence the outcome are now integral to the geometric design process. Early versions of the *AASHTO Policies on Geometric Design* (were published prior to the passage of such laws and regulations. Multiple governmental agencies have regulatory approval over various details of projects. Their input will shape the design solutions that emerge during the design process. States also may pass regulations or policies requiring accommodation of pedestrians and cyclists for certain roads or contexts; the ADA clearly influences the road design process. This aspect of the legal framework emerged after the early years of road-building in the United States, and most notably after initial design and construction of much of the Interstate System.

The environmental regulatory framework that evolved following passage of the National Environmental Protection Act in 1969 is now widely recognized as central to project development, and its permanence as part of the geometric design process must be acknowledged. NEPA and subsequent legislation place specific requirements on the highway design process, and the environmental and social performance outcomes of a design. The geometric design process now includes any number of analysis tools, data, and in many cases infrastructure to address regulatory issues.

Table 8. National Environmental Policy Act Legal and Regulatory “Umbrella”

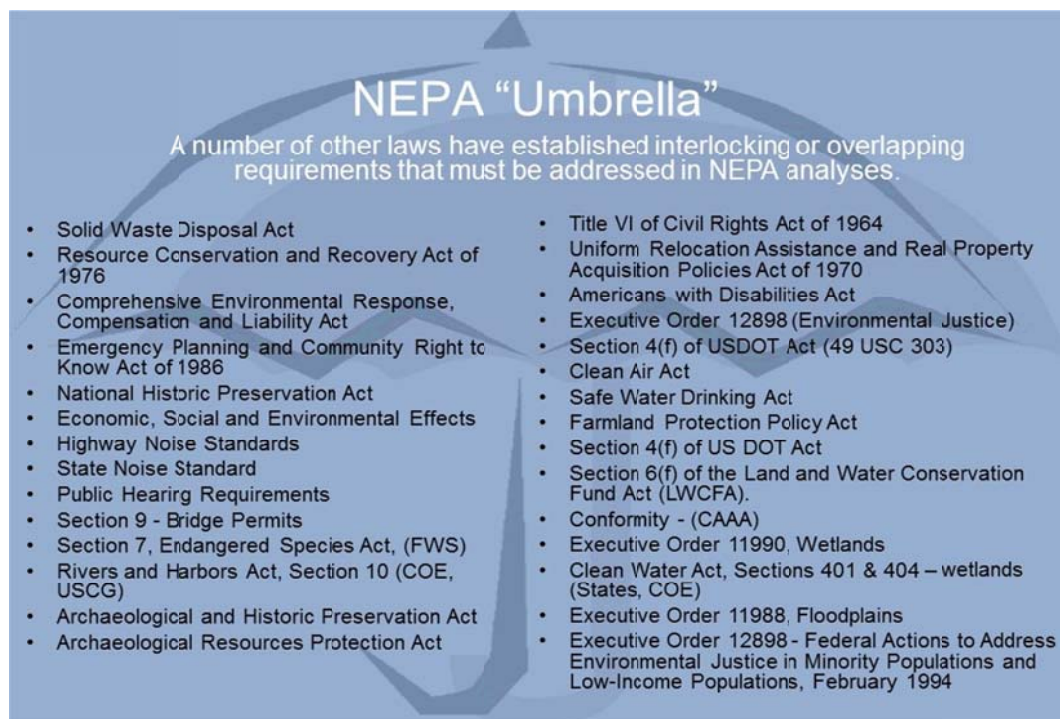

AASHTO has long acknowledged the social, economic, and environmental issues in design in the foreword to their Policy documents. However, the road design criteria and process has yet to fully incorporate what are not merely values but, in many cases, legal or regulatory requirements. An array of technical agency stakeholders has the responsibility of assuring that the laws and regulations referenced in Table 8 are adhered to properly. These technical agency stakeholders play a direct role in the geometric design process that is no less important than that of the highway design engineers.

Again, what often results is a design exception to address a regulatory constraint or issue. An optimal geometric process must directly include both the identification and specific influence on the three-dimensional roadway footprint of applicable environmental regulations and laws. And, it should not label design outcomes driven by legal or other formal policy issues, which are important elements of the project context, as being an exception.

#### 4.2.2.4 Laws and Regulations on Legal Motor Vehicles Manufacturing and Sales

A fourth aspect of the legal framework is the progression of requirements on motor vehicle manufacturing and sales in the United States. There are strict standards for vehicle performance, for incorporation of features such as seat belts, airbags, and side-impact protection, for performance in a collision (i.e., protection of the passenger compartment), for both passenger cars and trucks. Such regulations have had measurable impact on the survivability of crashes that formerly produced fatalities. Other aspects of vehicle regulation include height and width limitations, which influence vertical clearance and roadway or lane width criteria.

Vehicle attributes and their contribution to occupant safety and traffic operational efficiency have evolved significantly over the years. Features such as automatic braking systems, improved tires, and better suspensions mean the operation of the fleet is significantly different than it was 50 years ago. With the exception of a few variables, such as driver eye height, AASHTO geometric design policies have remained unchanged in the face of advances in vehicle technology.

The practical effect of motor vehicle regulation on geometric design is to influence (reduce) the severity of crashes that occur. A more performance-based geometric design process accounting for such effects may result in less costly infrastructure design, as the vehicle technology itself produces the intended driver/vehicle/roadway system performance. This also may be an outcome produced by self-driving vehicles.

The evolution of self-driving vehicles is rapidly occurring. The viability of the technology is now proven, but how such technology is transitioned within the vehicle fleet and the roadway infrastructure is uncertain. Claims of substantial improvement to safety performance are made with respect to many of the in-vehicle and infrastructure technologies. Such claims are associated with eliminating driver errors, which are a contributing factor in over 90 percent of crashes (18).

Vehicles that are truly driverless and error-free presumably would negate geometric requirements based on human needs for sight distance, extensive roadside infrastructure (guardrails, barriers, attenuation), and lane or roadway widths above a bare minimum. Such outcomes are years away, and the overall viability of truly driverless vehicles throughout the entire public roadway system is uncertain. A geometric design process based on performance outcomes, and that is continuously changing to reflect current conditions, will automatically adjust to real safety performance benefits that emerge. Crash modification factors or functions for geometric improvements would over time gravitate toward 1.0, meaning many roadway countermeasures would lose their effectiveness or have it significantly reduced.

#### 4.2.2.5 Public Policy Resource Allocation

The fifth and final aspect of the legal and policy framework is the allocation of resources to transportation agencies by their governing citizens, at the federal, state, and local levels. From the 1950s to the late 20<sup>th</sup> century, geometric design and road or highway design policies and standards at the national level have historically evolved independently of budgetary or resource limitations, or special transportation programs.

The development of 3R criteria in the 1980s was the first attempt to recognize and adopt some measure of cost-effectiveness in design decision making. The need for 3R criteria evolved over a time when many agencies began to transition from new road building to reconstruction of existing roads, with apparent difficulties in applying the published criteria. The evolution of the criteria involved some controversy, which mirrored the aforementioned conflicts in understanding the difference between nominal and substantive safety. A major research effort was required, which produced Transportation Research Board (TRB) Special Report 214 (19). This study focused on the need to relate road safety performance to physical dimensions or standards, as a basic premise behind cost effectiveness in design.

Approximately 15 years later, another similar controversy emerged in the design profession that had its roots in dissatisfaction over the cost effectiveness of geometric design criteria. County engineers who had long relied on the AASHTO Policies for design criteria of their road systems began to express discontent with the costs of the resultant designs and lack of apparent value. County engineers did not have access to federal funds for their systems and, in many cases, the overall funding available to them was far short of that available to their state DOT peers. County road systems are lower volume in nature, with substantial mileage of lower classification facilities.

County engineers did not have the resources or organization to develop their own design criteria, and so approached the American Society of Civil Engineers to conduct a study and make recommendations for revised design criteria for very low volume local roads (VLVR). The criteria were developed specifically to recognized principles of cost effectiveness and risk associated with lower volume, lower speed roads. They were intended to promote the concept of requiring less construction than higher volume, higher class facilities. AASHTO intervened and agreed to perform such a study, which was completed in 1998 (20). That resulted in the eventual completion and adoption by AASHTO of criteria for VLVR (21), which is referenced by many county engineers.

As a final example, consider the concept of the design domain, which is evident in design practices in many Canadian provinces. This principle acknowledges the practicalities of selecting design dimensions for a reconstruction road project to be in concert with the prevailing dimensions of the road and network to which the reconstructed road will be attached. Widening or upgrading a roadway to a higher standard when it will transition to the older standard may not make sense from both an economic or performance basis.

In the cases of 3R criteria development and VLVR criteria development, the geometric design process was disrupted or altered only following a widespread acknowledgement of a process flaw (i.e., the judgment that the



process and geometric criteria were not producing systematically cost-effective solutions, and were placing undue resource burdens on agencies using the criteria).

The lesson of these initiatives is that the roadway geometric design process should expressly acknowledge the inherent limitations in resources provided the agency by whatever funding programs or mechanisms are established. Such limitations include the amount of funding, designation of specific programs to be completed, allocations by geography, and other policy restrictions. A road design process that is conducted at the project level independently of overall program funding limitations cannot be assured of being sustainable over the long term.

The process should continuously be tested and adapt to resources and resource limitations. Many of the management initiatives begun in recent years at the state level (most notably, the concepts of practical design and Washington State DOT's design matrices) reflect an understanding that the historic design processes were insufficiently sensitive to what were perceived as permanent or long-term resource limitations. Agencies can no longer afford a road design process that leads to solutions that are clearly unaffordable, or that requires the labelling of cost-effective solutions as special cases or design exceptions.

### 4.2.3 The Design Process Should Support the Financial Sustainability of the Agency's Program

The road design process should be aimed at providing the best possible solution for a road or project that is part of an overall jurisdictional network of transportation to be maintained and operated by the owning agency over an indefinite future. This will require a fundamental change in both programming and project-level design decision-making processes and approaches.

Road design decision-making in the United States has traditionally been driven by a least initial capital cost decision model. Highway engineers design a road to meet a typically static, qualitative performance criterion using established design dimensions and criteria. The geometric criteria to a great extent define the right-of-way, cost and other resources necessary for project construction. The criteria are typically unchanged or minimally changed from year to year, and are to be used in a consistent manner for all projects. Finally, the geometric criteria in most cases are derived independent of maintenance or operating cost considerations in a meaningful or quantitative way.

A sustainable road design process is one that is aimed at minimizing the ***total life-cycle costs (construction and maintenance and operation over the total project life)*** within the context of achieving the purpose and need for the project (i.e., addressing the problems). In achieving the purpose and need, the project is expected to produce measurable societal transportation benefits over the total project life, such benefits to include lives saved, travel time reduced, and vehicle operating costs minimized. The agency's investment in the project should be commensurate with these forecast or quantifiable societal benefits. Moreover, a sustainable geometric design process is one in which the performance criteria that drive the geometric design reflect the practical limitations of both the project's context and the available resources set by the agency's policymakers and sponsors.

Transportation agencies do not just design and construct roads. They incur other substantial costs that attend to the functioning of their road system. Agencies also are responsible for the maintenance and upkeep of each project and their overall transportation system. For many agencies a substantial part of their annual budgets are now allocated to 3R, operations and maintenance functions, with actual new road construction and reconstruction expenditures much less. For example, a recent Government Accountability Office Report documented that 90 percent of FHWA's 2013 fiscal year obligations were spent on reconstruction or 3R type projects, and only 10 percent on new road construction (22). Figure 21 shows the 2013 budget for the Missouri DOT, which is a typical midwestern state primarily rural in character but with two major metropolitan areas (Kansas City and St. Louis). Maintenance costs are almost 20 percent of the total DOT budget, and more than one third of the budget for construction (23).

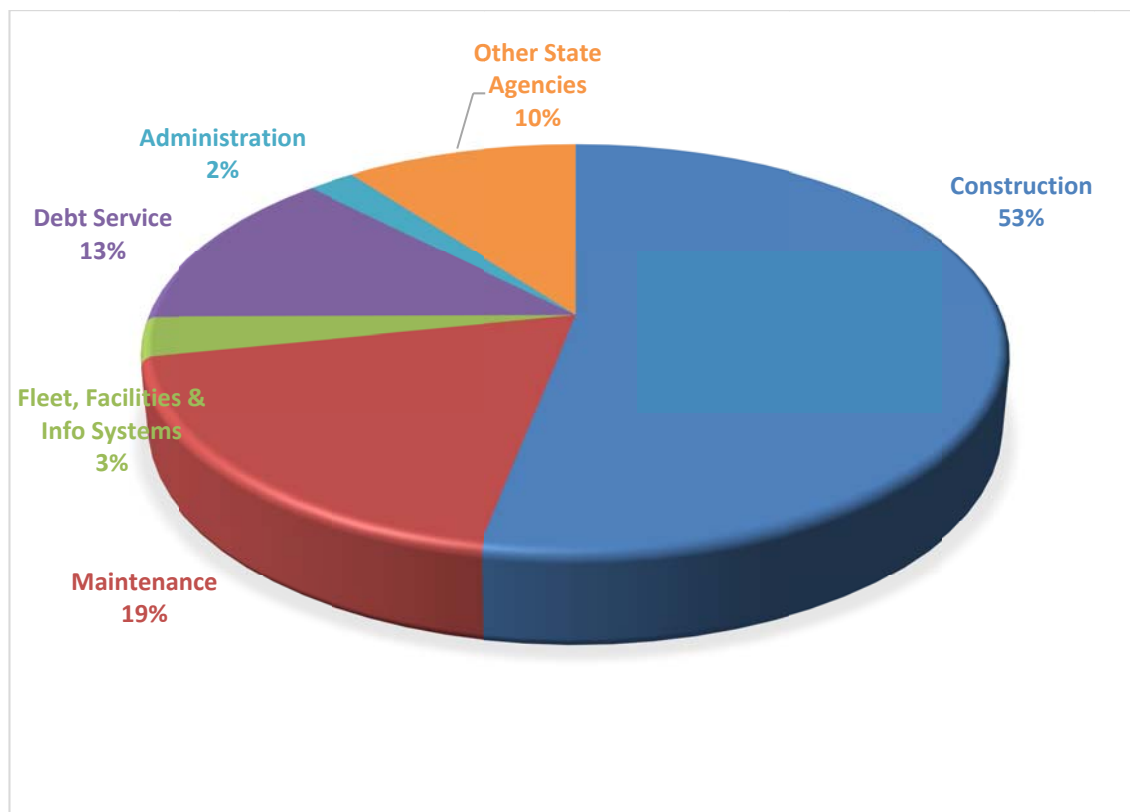

Figure 21. Allocation of 2013 Annual Budget for the Missouri DOT

Geometric highway design decision-making results in incurring costs to produce the measurable benefits. Different design solutions may create different or unique challenges or requirements associated with maintenance and operation. Once a project is constructed, the maintenance and operating (M&O) requirements, whatever they may be, become necessary outlays forever by the owning agency.

A geometric design decision process that ignores impacts on the M&O costs, particularly when these may be highly influenced by the geometric design itself, robs the agency of the ability to manage the long-term sustainability of the project and their system. The evaluation of M&O functions and costs and their incorporation into project development and design decision-making is thus an important recommendation for a financially sustainable road design process.

## 4.3 Attributes of an Effective Geometric Design Process

The following are core attributes of an effective geometric design process:

- The process must be efficient
- The process should be scalable
- The process must be executable by properly trained professionals in a consistent manner
- The process should be transparent
- The process must be defensible

### 4.3.1 Efficiency

Efficiency refers primarily to the data required and tools or methods that are core to process execution. Advances in technology now enable the efficient use of methods, tools, and approaches that were uneconomic 10 to 20 years ago. One should expect that continued advances in both knowledge and data gathering and maintenance will produce greater efficiencies over time.

The advances in computer-aided design and data gathering technologies offer the greatest benefits to a new design process. From the early days of design and construction to the early 1980s, the vast majority of time, labor, and expense associated with road design development was associated with the technical delivery of engineering construction drawings and associated documents such as specifications and construction quantity estimates. Calculations by hand were tedious and subject to error, requiring additional time for independent checking. Actual design plans including individual cross sections had to be hand drawn. Even minor revisions required costly significant re-engineering effort and redrafting. In this environment, resistance to considering design alternatives or continuously adjusting a design based on stakeholder comments were understandable, given the time and cost of completing the plans and specifications for construction.

Some of the time and effort to develop highway engineering design drawings is now devoted to application of other technical processes, models and tools that are either new to the profession or that represent significant advances in technology. Table 9 summarizes some of the important design tools used to support or characterize the safety, operational, or environmental performance impacts associated with the roadway design process. Many of these tools were developed in response to the need to respond to requirements of the aforementioned laws and regulations. Others represent advances in knowledge that allow more quantitative and empirical knowledge to replace assumptions or mere qualitative judgments.

*Table 9. Summary of Safety, Operations, and Environmental Tools Used in the Design Process*

<b>Safety</b>	<b>Operations</b>	<b>Environmental</b>
HSM Spreadsheets	Highway Capacity Software	TNM
IHSDM	Synchro	MOVES
CMF Clearinghouse	Sidra	EMFAC
RSAP	CORSIM	ArcGIS
RSAR	Vissim	
PBCAT	Paramics	
ISATe		

Highway engineers now have the ability to apply a full array of design tools and models to both rapidly and completely address not only the geometric features of the road, but many of its performance characteristics. The actual engineering design process is so much more efficient today that the production of engineering drawings is no longer on the critical path with respect to a typical project schedule.

***The efficiency of any project is now measured by the extent to which all stakeholder interests are properly accommodated, design alternatives appropriately vetted for their performance objectives, and the risks of unforeseen construction or other problems are eliminated or minimized.*** This is done through the appropriate, timely application of the full range of tools listed in Table 3, using readily available agency and project-specific databases.

### 4.3.2 Scalability

The term scalable refers to a project's size and scope, the complexity of the project, and, to an extent, the capabilities and resources of the owning agency. Fundamental guiding principles apply to all projects, but the extent to which they create complexity and the need for multiple sub-processes or analyses will vary. For many projects, the cost or time for collection and evaluation of much data may not be justified based on the nature of the project, thus requiring assumptions or default values. What is important is that the geometric design process take full advantage of the knowledge base regarding all aspects of the roadway infrastructure (design, construction, performance and maintenance) and employ suitably sophisticated models and relationships for those projects or programs that require significant investments.

Many agencies, particularly county and local governments, will be challenged by the data and technical needs associated with the design tools. Such challenges should not constrain the goal of a robust and data-centric performance approach. Rather, the needs of resource-constrained agencies can be met by careful development of shortcut procedures, programmatic data assumptions, and approaches that reflect the agency's context circumstances.

### 4.3.3 Executable

The term executable refers to the need for the roadway design process to be successfully completed by knowledgeable engineering professionals in a manner that is consistent within the agency. Properly trained and equipped design professionals using the same process and subprocesses should produce reasonably similar results, assuming the availability and quality of data are comparable. Similar results do not imply that the actual dimensions for road projects are the same, but rather that the manner in which solutions are studied and decisions made should be the same. Indeed, given that every location has unique context features, some measure of variance in the physical dimensions should be expected.

### 4.3.4 Transparency and Defensibility

The importance of transparency requires roadway design projects to involve both the allocation of limited resources that could be allocated to other projects or programs, and imposition of impacts to multiple stakeholders. The roadway design process is conducted in a public setting. Key subprocesses, data, and methods should be readily accessible to stakeholders and explainable in terms that can be understood.

The importance of transparency translates to a process that is defensible. A defensible design process may produce an outcome that some may find objectionable, but the process by which the design was completed and final decisions made should be defensible. Central to this attribute is the importance of all core technical models and subprocesses to have a firm, science-based, proven background.

Defensibility includes the appropriate documentation of all data inputs, subprocesses, and value judgments made in reaching the design decision. An important aspect of defensibility is the ongoing protection of the agency against future tort actions based on allegations of error or negligence.

## 4.4 References

1. Hauer, E., 'Safety in Geometric Design Standards,' 1999.
2. Neuman, T.R. et al., National Cooperative Highway Research Program Report 480, 'A Guide to Best Practices for Achieving Context Sensitive Solutions,' Washington, DC, 1992.
3. Fambro, D. et al., National Cooperative Highway Research Report 400, 'Determination of Stopping Sight Distances,' Washington DC, 1997.
4. American Association of State Highway and Transportation Officials, A Policy on Geometric Design of Highways and Streets, 2011 edition, Washington DC.
5. Harwood, et al., National Cooperative Highway Research Program Report 505, 'Review of Truck Characteristics in Roadway Design, Washington, DC, 2003.
6. Fitzpatrick, K. and Wooldridge, M., National Cooperative Highway Research Program, Synthesis Report 299, Washington, DC, 2001.
7. Ross, H.E. Jr et al., National Cooperative Highway Research Program Report 350, 'Recommended Procedures for the Safety Performance Evaluation of Highway Features,' Washington, DC, 1993.
8. American Association of State Highway and Transportation Officials, Manual for the Assessment of Highway Safety Hardware, 1st edition, Washington DC, 2011.
9. Transportation Research Board, Strategic Highway Research Program 2 (SHRP2), <http://www.trb.org/StrategicHighwayResearchProgram2SHRP2/pavement.aspx>
10. Association of Metropolitan Planning Organizations website: <http://www.ampo.org/resources-publications/best-practices/land-use-transportation-planning/>
11. National Conference of State Legislatures website: <http://www.ncsl.org/research/transportation/bicycles-and-pedestrians.aspx>
12. Glennon, J.C., 'Roadway Defect and Tort Liability,' Lawyers and Judges Publishing Company, 1996.
13. American Association of State Highway and Transportation Officials, 'A Guide for Achieving Flexibility in Highway Design,' Washington, DC, 2002.
14. Neuman, T.R. and Stein, W. 'Mitigation Strategies for Design Exceptions,' Federal Highway Administration, Washington DC, 2007.
15. Mason, J. M. Jr. and Mahoney, K.M., National Cooperative Highway Research Program Synthesis Report 316, 'Design Exception Practices,' Washington, DC. 2003.
16. Stamatiadis, N., et al., 'Design Exceptions and Safety,' Transportation Research Board 3rd International Symposium on Geometric Design, Chicago, IL, 2005.
17. Bonneson, J. A. et al., National Cooperative Highway Research Program Final Report for Project 17-45, 'Safety Prediction Methodology and Analysis Tool for Freeways and Interchanges,' Washington, DC, 2012.
18. American Association of State Highway and Transportation Officials, Highway Safety Manual 1st edition, Washington DC, 2011.
19. Transportation Research Board, Special Report 214, Designing Safer Roads, Washington DC, 1987.
20. Neuman, T. R., National Cooperative Highway Research Program Project 20-7, Task 75, Final Report, 'An Update to AASHTO's Guidelines for Geometric Design of Very Low-Volume Local Roads, Washington DC, 1999.
21. American Association of State Highway and Transportation Officials, Guidelines for Geometric Design of Very-Low-Volume-Local Roads (ADT < 400) 1st edition, Washington DC, 2001.
22. U.S. Government Accountability Office, Report GAO-15-33, 'DOT Has Opportunities to Improve Tracking and Reporting of Highway Spending,' Washington DC, October 2014.

23. Missouri Department of Transportation Website (<http://www.modot.org/>)
24. Federal Highway Administration Office of Innovative Project Delivery website:  
[http://www.fhwa.dot.gov/ipd/project\\_delivery/resources/cost\\_estimating/default.aspx](http://www.fhwa.dot.gov/ipd/project_delivery/resources/cost_estimating/default.aspx)
25. Institute of Transportation Engineers (ITE), 'Designing Walkable Urban Thoroughfares: A Context Sensitive Approach –ITE Recommended Practice,' Washington DC, 2010.
26. U.S. Government Office of Management and Budget website: <http://www.whitehouse.gov/omb>
27. Transportation Research Board, Highway Capacity Manual, 2010 edition, Washington DC, 2010.
28. American Association of State Highway and Transportation Officials, A Manual on User Benefit Analysis for Highways, 3rd edition, Washington DC, 2011.
29. Campbell, J. L. et al., National Cooperative Highway Research Program Project Report 600, Human Factors Guidelines for Road Systems, Second Edition, Washington DC, 2012.
30. Elvik, R. et al., 'The Handbook of Road Safety Measures, 1st and 2nd editions, (2004 and 2009).
31. Washington Department of Transportation website:  
<http://www.wsdot.wa.gov/Projects/ProjectMgmt/RiskAssessment/>
32. National Building Information Modeling Standards website: <http://www.nationalbimstandard.org/>
33. Zegeer, C.Z. and Neuman, T. R., National Cooperative Highway Research Program Project Report 362, 'Roadway Widths for Low Traffic Volume Roads,' Washington DC, 1993.
34. Lord, D. et al., 'Modeling Crash-Flow-Density and Crash-Flow-V/C Ratio Relationships for Rural and Urban Freeway Segments,' Accident Analysis and Prevention, 2004.
35. Austroads website:
36. <https://www.onlinepublications.austroads.com.au/collections/agrd/guides>
37. Glennon, J.C., Neuman, T.R. and Leisch, J.E. Safety and Operational Considerations for Design of Rural Highway Curves. Federal Highway Administration Report FHWA/RD-86-035, Washington DC, 1985.
38. Lamm, R. et al., Transportation Research Board, Record 1100, 'Comparison of Different Procedures for Evaluating Speed Consistency,' Washington DC, 1986.
39. Harwood, D. W. et al. 'Truck Characteristics for Use in Highway Design and Operation.' Reports FHWA-RD-89-226 and FHWA-RD-89-227. Federal Highway Administration, Washington DC, 1990.
40. Krammes, R. A. and Otteson, J. L., Transportation Research Board, Record 1701, 'Design Speed and Operating Speed in Rural Highway Alignment Design,' and 'Speed-Profile Model for a Design-Consistency Evaluation Procedure in the United States,' Washington, DC, 2000.
41. Neuman, T. R., Transportation Research Board, Record 1208, 'New Approach to Design for Stopping Sight Distance,' Washington DC, 1989.
42. Harwood, et al, National Cooperative Highway Research Program Report 783, 'Evaluation of the 13 Controlling Criteria for Geometric Design,' Washington, DC, 2014.
43. Harwood, Douglas W., Mason, John, Brydia, Robert, National Cooperative Highway Research Program Report 383, 'Intersection Sight Distance,' Washington DC, 1996.
44. Harwood, D.W., K.M. Bauer, and I.B. Potts, Transportation Research Record 2398, "Development of Relationships Between Safety and Congestion for Urban Freeways," Washington, DC, 2013.



## 5 Recommended Highway Design Process

This section of the report outlines the recommended geometric highway design process. The highway design process is a major part of the overall transportation project development process. Successful completion of key elements and tasks of the overall process are essential to the success of the highway design process. Figure 22 illustrates a typical, simplified project development process that is modeled after many state DOT processes.

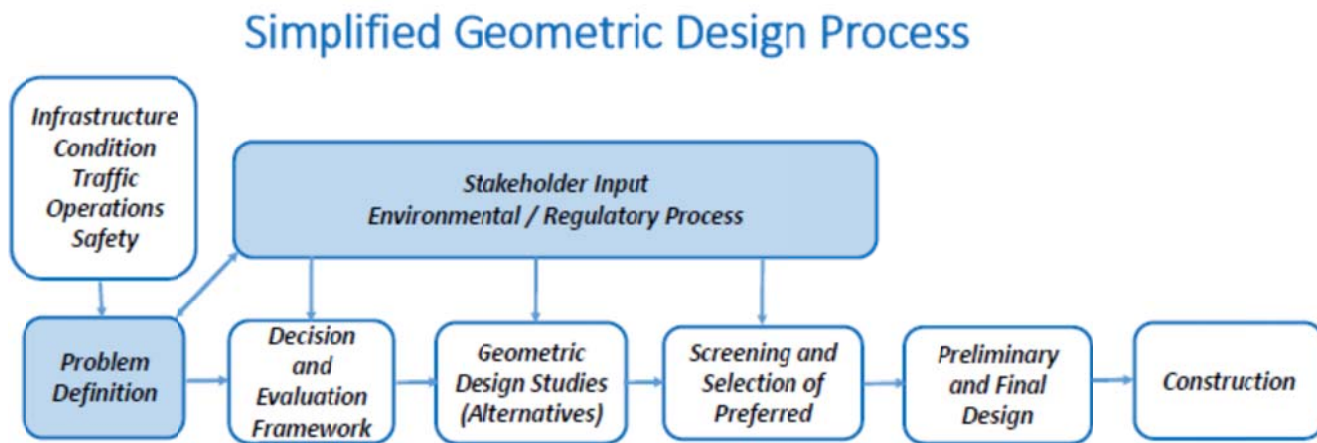

Figure 22. Roadway Design Development Process

NCHRP Report 480 (2) documented a framework for project development that reflects the evolution of highway projects over the past 30 years. The critical success factors to highway and road project completion are fourfold:

- Employ effective decision-making process
- Reflect community values (i.e., include stakeholders)
- Be environmentally sensitive
- Implement safe and feasible solutions

These critical success factors align with the Guiding Principles discussed above. The importance of geometric design decision-making reflects on the accountability of the agency to its customers and to those providing the resources and funds. Reflection of community values and sensitivity to the environment emphasize the importance of context as broadly defined in what constitutes reasonable outcomes. Finally, the notion of safety as being central to successful design policy is self-evident; and the term feasible applies to both the individual project and its role or contribution to the overall road network. Feasibility encompasses both the physical aspects and footprint and the affordability of the project.

These critical success factors are reflected in the highway design project development steps outlined below for the revised and improved geometric road design process.

### 5.1 Step 1 – Define the Transportation Problem or Need

All street, highway, or transportation projects have common characteristics. The first and foremost step is to define and articulate a transportation need.

There must be a reason why the owner is spending time and money. Agency programs are developed around the continual oversight of the transportation performance measures of mobility (congestion, level of service [LOS]) and access, safety (crashes and their outcomes), and state-of-good repair (pavement and bridge asset management). A project may also emerge from a need to fulfill a mission or vision of a community such as redevelopment or urban renewal, which would create an accessibility to land problem.



## Recommended Highway Design Process

***Step 1 - Define the Transportation Problem or Need***

***Step 2 - Identify and Charter Stakeholders***

***Step 3 - Develop Project Scope***

***Step 4 - Determine Project Type and Design Development Parameters***

***Step 5 - Establish Project Context and Geometric Design Framework***

***Step 6 - Apply Appropriate Geometric Design Process***

***Step 7 - Designing the Geometric Alternatives***

***Step 8 - Design Decision-Making and Documentation***

***Step 9 - Transition to Preliminary and Final Engineering***

***Step 10 - Agency Operations and Maintenance Database Assembly***

***Step 11 - Monitoring and Feedback to Agency Processes and Database***

Figure 23. The Steps of the Recommended Highway Design Process

***Historically, the highway design process has, in many cases, been performed independently of the statement of purpose and need. For reasons of economy, efficiency, and a focus on cost-effective solutions, the geometric road design process should be strongly bound to and driven specifically by the problem or needs being addressed.***

Clearly defining the problem is the first step in an effective decision process. A feasible solution can only be one that clearly addresses the problem. AASHTO reinforces the importance of this first step in their policy document on highway design flexibility (13). Defining the problem in all its transportation aspects is a critical initial step.

*Only after a clear understanding has been reached by all stakeholders regarding the need for the project, including what transportation issues and problems it is intended to address, can progress toward problem solving and actual implementation occur.*

**AASHTO Guide for Achieving Flexibility in Highway Design**

Of great importance is the need for each project's problem statement to be objective. Problems with pavements may be rutting, lack of drainage, or cracking. Bridge condition problems may vary from substructure condition, to vertical clearance, to superstructure condition; or load-bearing capability. Transportation mobility problems should be defined in explicit, performance-based terms (e.g., travel time during x hours of the day, delays at location y, distance to walk from A to B). Substantive safety problems should be defined in terms of the frequency of specific types of crashes at specific locations. Accessibility should be addressed in terms of modes and specific origins and destinations of trips. Subjective and vague problem statements referring to user perceptions, or livability, are unhelpful and should be avoided absent further explanation of what the terms mean.

Problems based on objective performance measures should directly reflect agency policies and priorities. These are translated and communicated through reference benchmarks that are statistically valid and relevant to the specifics of the project. Thus, a pavement considered in need of repair earns that designation through objective condition assessments and references to the agency's asset management approaches to pavement. Safety problems are identified through the appropriate statistical analyses of crash data by frequency, type, and severity. Qualitative or opinion/subjective based problem statements should be avoided as they offer no basis for validating the expenditure associated with a geometric or other solution. This thought also applies to agency programs with specific performance focuses, for example, the systemic safety approach.

***The importance of a strong, objective problem statement in the context of geometric design cannot be overstated.*** An appropriate, geometric design solution is one that will address the problem in meaningful, measurable ways. Moreover, as the nature of the problem is unique to the location, the specific geometric design solution may be unique, or at least may be different from the solution applied at another location with similar context features but differing problems.

## 5.2 Step 2 – Identify and Charter All Project Stakeholders

Highway and transportation projects are intended to provide a service and benefit to the general public. For the most part, they will be funded using public resources. They may require the conversion of privately owned land to public right-of-way. They will require the ongoing allocation of funds for the upkeep, maintenance, and operation of the roadway. They may create impacts, some of which may be adverse, on adjacent properties or entities. ***For all of these reasons, the highway geometric design process must be viewed as an open, transparent, and ultimately public process, and not just the purview of the technical staff of the transportation agency.***

Every highway project regardless of size or location involves multiple stakeholders. The term stakeholders refers to any individual or organization having a stake in the project. The stake may be direct as is the case for the owner of the road, the users of the road, and those directly influenced by its design and construction. Some stakeholders may have more indirect stake in the project. Indirect effects may include socioeconomic impacts in the area or region, expected changes in land values or utility in proximity to the project, aggregate regional environmental effects, or other similar impacts that may affect people but are less measurable directly or are uncertain in their timing and extent.

***A highway design project team cannot possibly be successful without understanding and incorporating the meaningful input of key stakeholders in all relevant aspects of the project.***

### 5.2.1 Internal Agency Stakeholders

Within the agency that owns the project, the stakeholders include all different departments from which data, input, or assistance is needed. In addition to the road design department, other internal stakeholders will typically include traffic engineering, safety, maintenance, construction, public relations, and environmental planning. City and county internal stakeholders also may include departments responsible for planning and zoning, economic development, and law enforcement. Any department that may be asked to provide resources to implement and maintain the project is an internal stakeholder that should be fully engaged or represented throughout the project.

### 5.2.2 External Agency Stakeholders

Other governmental bodies may be affected by or have regulatory power over one or more aspects of the project. External agency stakeholders may include a local government or county department of public works, the U.S. Army Corps of Engineers, state natural resource and environmental agencies, state cultural resource agencies, and others. These stakeholders may be responsible for review and approval of project plans, permitting, and ensuring mitigation of identified adverse project effects.

Other key external agencies include law enforcement and emergency service providers, local transit agencies and providers, and public utilities. Their common stake is in the use of the road or road network to conduct their jobs, locate their facilities, and serve their customers.

### 5.2.3 Other External Stakeholder Groups or Agencies

Other external stakeholders may include organizations, groups, or agencies that provide data or input, give advice and counsel, or represent general interests having to do with transportation or land use and social policy. These may include:

- Political jurisdictions within which the roadway passes
- Metropolitan Planning Organizations (MPOs)
- Non-governmental organizations
- Local environmental agencies
- Social outreach agencies
- Chambers of Commerce and other business groups
- Schools and school districts
- Community interest groups
- Road user groups such as AAA, Freight and goods community, bicycle advocacy groups

These external stakeholders will often become heavily engaged in larger projects of a regional nature. External stakeholders typically do not have a direct role in project decision-making other than advisory or reaction and comment, but their influence individually and collectively will often substantially shape the design solution.

## 5.2.4 Directly Affected Stakeholders

Stakeholders who are directly affected include those whose property may be taken, or access affected during construction, or in the final plan. The input of these stakeholders has a direct influence on important road design decisions. Permanent spatial impacts to properties and access, to mobility in the corridor for all users; impacts during construction (road closures and detours, noise and dust, and construction vehicle routings) are all common issues that highway designers must consider.

## 5.2.5 Stakeholder Chartering

The concept of chartering refers to formal acknowledgement of each stakeholders' presence and reason for having an interest in the project. It includes agreement on the roles of stakeholders, which may range from advisory to decision making; timing and methods of communication; and, most importantly, validation of the problem being addressed.

Chartering as a subprocess is scalable. For many projects, it may consist of a single meeting at which the basics of the project are discussed, communication protocols set, schedules discussed, and agreement reached on timing and nature of each individual's input. Some projects may involve mostly internal agency stakeholders and hence chartering may become an internal routine. An important aspect of chartering regardless of the project size is the documentation and joint ownership of the project by all involved. This is often accomplished by having stakeholders sign and acknowledge the notes or meeting minutes that document decisions and actions. Chartering as described here can be included as part of Step 3, Project Scoping.

## 5.3 Step 3 – Develop the Project Scope

The term scoping refers to the setting of the parameters of the project. Scoping includes engaging the many stakeholders with varying interests and concerns. Regardless of the purpose and need, these concerns will shape the alternatives and ultimately drive or influence the selection of the preferred alternative. Broadly stated, stakeholder concerns will involve one or more of the following areas:

- Implementation and life-cycle costs including maintenance
- Need for right-of-way (amount, location, conversion of existing use)
- Environmental considerations (air, noise, water quality, socioeconomic effects, visual effects; construction issues such as dust, truck movements, noise)
- Specific community concerns such as key landmarks, important land uses, or buildings
- Transportation operations and service (types and modes of travel, quality of service, access to abutting properties)
- Public safety (users of the road or facility; safety interactions of stakeholders with users)

Depending on the project, many of these issues may be conducted within a strict set of regulatory protocols or requirements. Scoping serves to define the amount, type, and eventual use of data gathering and analysis steps. In the case of programmatic projects, such as a systemic safety project, the scope will include the jurisdictions and road types to be included.

Within the context of geometric design, there are three key elements to project scoping and each of the elements have an impact on each other – **(1) refinement and confirmation of the problem statement and definition with stakeholders, (2) determination of project type, and (3) setting of project and study limits and major study parameters and constraints.**

### 5.3.1 Refinement and Confirmation of Problem or Needs Statement

The transportation problem or needs statement developed in Step 1 should be presented, discussed, confirmed and/or revised based on input from key stakeholders both inside and outside the owning agency. The importance of this step is twofold. First, efficiency demands those involved in the project understand and maintain the focus on why the project is being performed. Limitations in resources and schedule pressures are such that every effort should be made to avoid diversion from the core mission. The sharing of the problem can uncover opportunities to refine or expand the project to include other objectively defined problems within the project that are directly related to or coincident with the road or portions thereof. Second, the specific definition of the problem should translate directly into the appropriate geometric design process, as discussed in detail below.

Stakeholder discussions should be facilitated in a manner that generates objective and well-understood problems expressed in neutral ways (i.e., that do not bias or presuppose a solution). Stakeholders should understand agency data and analysis methods that express problems associated with congestion, delay, or safety performance. Vaguely described concepts expressed in terms such as sustainability or livability are often not helpful. Opinions (the road is unsafe) must be supported by objective relevant data to be useful. Expressing problems as lack of xx should be avoided, as the solution is implied in the way the problem is expressed. Finally, to the extent possible, problems should be referenced to the location or locations where they exist or are perceived; or to the specific type of conflict or crash type.

A useful statement of purpose and need will direct the development and evaluation of potential solutions. It will facilitate the selection of a solution that produces measurable value in terms of solving all or part of the problem for the resources invested.

Confirmation of the problem in objective and data-driven terms clearly communicates to all stakeholders what the agency's approach will be in the geometric design process. Problem statements should be understood as driving the approach to the geometric design solution. This includes geometric elements to include, their dimensions, and locations (e.g., intersection, curve) of specific concern.

A refined, formal problem statement is the key outcome from Step 3. This should be highlighted in the chartering document. It also will form the basis of the purpose and need which is a central element of the environmental process.

## 5.4 Step 4 – Determine the Project Type and Design Development Parameters

Once the stakeholders have been consulted and the problem statement published, the agency makes a determination of the type of project. Project type refers to the pre-existing condition and fundamental nature of the identified problem(s) or needs.

The revised geometric design process encompasses these three basic project types:

- New roadway (on new alignment with newly acquired right-of-way)
- Reconstructed roadway (along existing right-of-way but with substantial change in the roadway characteristics and potential additional right-of-way)
- 3R roadway (resurfacing, restoration, and rehabilitation of an existing roadway within the existing right-of-way; with only minimal changes to the road's geometric characteristics [at most])

Project scoping should include the confirmation of the type of project, which should direct and drive the highway design process and ultimately the solution. ***New roadway projects are fundamentally different from reconstruction and 3R projects in ways of sufficient import to warrant treating them differently.***

To review, by definition, a reconstruction project involves a roadway already in place and functioning. Similarly, a new construction project (one on new alignment) introduces a new transportation corridor where none exists. The following differences are evident:

- With an existing road, the abutting land use has developed around the mobility and access provided by the road; with a road on new alignment the road itself always produces significant change (positive and potentially negative).
- With an existing road, there is a clear and well-understood operational and safety performance history; none exists for a road on new alignment.
- The costs of construction and constructability of each project type are based on significantly different factors.

### 5.4.1 Unique Characteristics of New Roads

New roads or projects on new alignment are different from other project types. First, a new road is typically built to address problems of access and/or mobility only (and not to address an existing safety problem). New roads will substantially change the surrounding land use. In many cases, such changes are not only positive but intentional. Providing access to land creates development opportunities. Segmentation of large parcels such as agricultural land changes the economics and potential value of such lands. Existing regional and local travel patterns will substantially change, as the new road presents re-routing opportunities.

Forecast traffic volumes and travel patterns are inherently more uncertain for new roads. Travel behavior including speed, crashes, and conflicts may be estimated based on tools and models, but the actual route choices of potential users are unknown prior to opening of the road.

The costs and difficulties of constructing new roads are typically associated with context features of the terrain, geology, and water courses. Alignment siting studies focus on avoidance of conflicts with concurrent utilities, and respecting property boundaries by avoiding unusable remnant parcels and assuring public access. Cost estimates for construction are primarily based on the quantities of major elements including earthwork, structural features, and pavement.

Given the uncertainties inherent in new road construction, the geometric design approach may differ from existing roads. Agencies may reasonably acquire sufficient right-of-way to enable future changes to the road based on potential unforeseen development and traffic growth beyond the nominal design year. Bridges and other major structures may be built to accommodate potential widening beyond the design year, especially when the incremental costs of construction of wider crossings is minor. Finally, a geometric design process utilizing traffic operational and safety performance models should consider the uncertainty in the input data to the models and their overall quality or reliability.

### 5.4.2 Unique Characteristics of Reconstruction Projects

Properties with site development and access directly tied to the existing road geometry within a fixed right-of-way footprint makes reconstruction projects different from roads on new alignment. This difference tends to be magnified in built-up urban and suburban areas. Where real estate is highly valued, developments will use every foot of available land, and public rights-of-way will be limited to the area needed for all infrastructure. The abutting land use will often be fully occupied by buildings, parking, planned developments, and plazas. In-place developments will reflect local ordinances for setbacks, parking requirements, storm water mitigation, and other features. Utilities, both underground and aboveground, are situated with reference to the existing road.

#### 5.4.2.1 Effects of Additional Right-of-Way Acquisition

Mature developments are the economic and social fabric of the community, and are the source of employment and tax revenues. Reconstruction of an existing road bears a special, significant burden of minimizing damage or disruption to property owners (businesses, residents, government agencies) who invested in their land based on the right-of-way and footprint of the existing road. Reconstruction projects that require taking of new right-of-

way, even as much as a relatively small strip taking of 5 feet will often produce adverse impacts beyond the direct cost of the right-of-way itself. Such impacts may include:

- Elimination of building set-backs required by local ordinance, thus rendering the property as non-conforming to such ordinance
- Loss of mature landscaping and plantings serving as visual buffers between the road and development
- Loss of site parking, again rendering the property as non-conforming and potentially damaging the economic viability of the development
- Newly created conflicts with existing utilities (both subsurface and aboveground)
- Reduction of the sidewalk widths/offsets to the travelway

It is not uncommon for the taking of even a small strip to be considered so adverse as to render the remaining property uneconomic and hence requiring a whole taking.

#### 5.4.2.2 Changes in Access and Their Effect on Adjacent Properties

Reconstruction projects will also frequently produce changes in access. Such changes may be related to necessary realignment, safety enhancements, and/or operational improvements. In most cases, changes in access (e.g., loss of driveways, closure of medians, consolidation, or relocation of access) will be considered adverse by the abutting property owners. Depending on the nature of the land use (commercial, retail, types of retail) such changes unless mitigated can have measureable, permanent adverse effects on businesses.

#### 5.4.2.3 Disruption to Traffic and Access during Reconstruction Produces Adverse Economic Impacts

Reconstruction may involve changes to the three dimensions of the roadway. In most cases, maintaining traffic during construction along the corridor is required. Access to properties by emergency vehicles at all times is necessary. These important factors often result in even relatively straightforward geometric design projects requiring more than 12 months to complete construction. Even when through traffic is maintained and temporary driveway connections provided, the quality of service during construction is much worse than before construction. When this condition exists for extended time periods, the economic impacts to businesses can be substantial. This problem may exist even for projects reconstructed completely within the right-of-way. This issue also occurs with 3R projects, but resurfacing and restoration (and not major changes in alignment or profile) take much less time to construct, and thus generally result in lesser economic burdens to adjacent landowners.

#### 5.4.2.4 Costs of Construction

Unlike new roads, the costs of reconstructing existing roads are based on many factors beyond the earthwork, pavement, and structural quantities. As noted above, the need to maintain traffic greatly influences the number of separate construction phases, viability of means and methods of construction, and length of time to construct. Site access to the existing corridor by construction vehicles may be highly restricted or limited (avoiding truck traffic on local streets or commercial areas). Time-of-day restrictions on truck activity are common. These necessary constraints can have substantial effects on the unit costs of earthwork, concrete, and other materials for the specific project. As utilities typically occur within the existing right-of-way, conflicts arise and the need to relocate the right-of-way (thus incurring additional phases and time) are inevitable. While these factors are typical, their relative importance and direct influence on an optimal design are highly context sensitive. For reconstructed roads, an optimal or minimal construction cost is a much more involved and variable exercise than for a comparable road constructed on new alignment.

#### 5.4.2.5 Transportation Performance is Known and Measurable

Finally and most importantly, roads to be reconstructed have a known, observable traffic operational and safety profile. Indeed, it is the measurable performance of the road combined with agency policies and performance benchmarks that should have been used to frame the problem statement and define the need. Actual traffic volumes and patterns, crash frequency and severity, and speeds are measurable. The availability of such data is

both unique and critical to reconstruction (and 3R) project design development. Traffic forecasts are generally more reliable, particularly where the road network and development are mature. ***The ability to use location-specific data of adequate quality is a unique, valuable aspect of reconstruction projects as compared with new alignment projects.***

### 5.4.3 Unique Characteristics of 3R Projects

The third type of project is 3R, which involves addressing the state-of-good-repair of the infrastructure and only involve existing facilities. The land use and access impacts of reconstruction projects discussed above also apply to 3R projects. A project for which the state-of-good repair is the core problem is potentially eligible for 3R designation.

A key stakeholder input process step may include discussion of whether or not other problems identified by stakeholders could or should be incorporated into the project. For example, an urban street repair project to address failing pavement may be viewed by some stakeholders as an opportunity to provide or enhance pedestrian accessibility or mobility by incorporating sidewalks, intersection ramps, pedestrian signal upgrades, or to include restriping of the pavement to include bicycle lanes. These measures would address a stated problem associated with access and/or mobility of pedestrians or bicyclists.

(NCHRP Project 15-50 is currently considering revised geometric design guidelines for 3R projects to replace those developed in the later 1980s for TRB Special Report 214. The vision and approach of the authors of that effort are generally consistent with the approach suggested here.)

### 5.4.4 Project Types and Transportation Problems

Figure 24 demonstrates the range of possible problems associated with the three project types. A project on new location will always involve addressing a mobility problem, accessibility issue, or both. An important process step for new location projects is a full stakeholder discussion and agreement on how the travel modes will be accommodated, including motor vehicles, freight, transit, pedestrians, and bicycles.

Project Type	Transportation Problem			
	Mobility	Access	Safety	State-of-good Repair
New Location	X	X		
3R				X
Reconstruction	X	X	X	X

Figure 24. Project Types and Transportation Problems

Confirming and potentially expanding the problem definition based on stakeholder input is a key process step. A 3R project may proceed with additional features added without changing the basic project definition or purpose of the project. But depending on the project specifics and additional problems suggested, the scope of the project, applicable type, and design approach may significantly change.

***An effective and responsive highway design process resolves problem definition and designates the appropriate project type early in the process.***



A reconstruction project may involve any of the fundamental problems, or combinations thereof. Indeed, what differentiates a 3R from a reconstruction project will be the identified problem(s) or need(s) associated with traffic operations, safety performance, or both. As with a 3R project, stakeholders should be consulted with respect to enhancing the problem definition to include the full range of multi-modal interests.

### 5.4.5 Setting of Project Limits and Major Study Parameters or Controls

Each project has geographic limits or boundaries. These can be as small as a single intersection, a street in front of a school, a short segment along a highway; or a corridor of some length that may contain one or more routes. The context of the project's location should shape and determine study approaches, feasibility of alternatives, stakeholder involvement strategies, and performance characteristics. Agency stakeholders responsible for specific resources shape the scope of the project. They may identify resources to be avoided, remind project staff of regulatory requirements, and help establish technical protocols.

The project limits and indeed those segments of existing road to which the project ties also are important design process features. A road segment being reconstructed should be designed with cross section dimensions compatible with the sections of road to which it ties. This concept is referred to as the design domain, an element of road design decision-making in Canada. Thus, for example, a long segment of road may have 10-foot lanes and 3-foot shoulders. If one portion of that road is to be reconstructed, with sections on either end to remain, reconstruction using 12-foot lanes and 6-foot shoulders (which may be the applicable standard) may not make sense operationally, and be more costly than using lesser dimensions more compatible with the existing roadway (this of course depends on the problem being addressed and whether the cross section dimensions are attributed to the problem).

Project limits for new roads and major reconstruction are subject to environmental regulations that require the project have independent utility. Knowledgeable environmental process stakeholders should participate in setting limits for such projects.

### 5.4.6 Determining Environmental Process and Documentation Requirements

The scoping process in Step 3 includes the expected level of environmental analysis and documentation (either federal, state, or local), which reflects the overall scope, and understanding of constraints and expected impacts. It is based on input from key environmental stakeholders both inside and outside the agency. An important consideration is the extent to which new right-of-way acquisition is expected. This type of impact may in itself require a project to be performed as an environmental assessment (EA) rather than a categorical exclusion (CE). Recognizing that right-of-way impacts are uncertain at the beginning of the design process, the type of problem and type of project should provide firm direction to the geometric design team. Addressing pavement condition for a two-lane rural highway with no observable safety performance problems should generally not involve right-of-way, as there should be no compelling reason to 1) widen the lanes or shoulders; 2) flatten a horizontal curve; 3) lengthen a vertical curve; or 4) flatten a roadside slope or increase the clear zone.

### 5.4.7 Establishment of Planning Level Implementation Budget

With the project type and limits established, a project construction or implementation budget and schedule should be readily set based on historic data. The budget should reflect the reasoned judgments of the type and nature of the constructed project elements. This budget should be a reference point against which the project manager and team will be evaluated during project tasks and following completion.

Many major projects historically suffer from unrealistically low initial budgets. This issue has been studied and recent efforts led by the FHWA have focused on how such budgets are developed, and how they are monitored during project development (24). Major projects seeking federal funding cannot proceed without a detailed financial plan, which matches financing sources with estimated project costs.

Having a reasonable budget that reflects the unique project conditions, and is continuously referenced throughout the project development process, is an essential element of a geometric design process. The

importance of including a preliminary budget as part of the design process is to remind the project team of their project's role within a greater agency program. A project designated as 3R should have a level of investment well understood by all involved. Changes in project circumstances that would produce substantive changes in the budget should be discussed thoroughly prior to investing resources or proceeding ahead.

## 5.5 Step 5 – Establish the Project's Context and Geometric Design Framework

The geometric design framework is comprised of external controls and constraints (the context), input data and assumptions, design controls that are choices or at the discretion of the designer or his/her agency, applicable policies of the owning agency, and decision-making processes and responsibilities for the project. Some aspects of the framework apply to all similar projects performed by the agency, and others are specific to the project.

The project context is the set of conditions, controls, and constraints outside the control of the designers (givens). These include location, terrain, climate, land use, and political or jurisdictional boundaries.

Current AASHTO design policy addresses the context in just two dimensions, characterizing location as urban or rural, and terrain as level, rolling, or mountainous. This framework has been in place since the first versions of the AASHTO Policies in the 1950s. It is based primarily on motor vehicle operational needs and the costs and practicality of project implementation for roads on new alignment in differing area types and terrain.

A much more robust framework is needed that further differentiates important external controls on appropriate geometric solutions. The need for a more robust framework is primarily associated with the need to tailor the geometric design process for contexts in which multi-modal travel, and in particular pedestrian and other vulnerable user mobility and safety, should be the predominant concern.

### 5.5.1 Framework for Geometric Design Process - New Construction and Reconstruction

This section outlines a suggested framework and straw-man demonstration of its application in the development of a revised basis for geometric design criteria for new construction and reconstruction projects. The framework incorporates the basic principles discussed above. It considers both transportation function and value, and costs and cost-effective principles. Figure 25 shows the format of a matrix for the context framework for geometric design criteria. The two-dimensional context framework includes road type, and an expanded, land use context definition.

Roadway Type	Rural Natural Zone	Rural Zone	Suburban Zone	General Urban Zone	Urban Center Zone	Urban Core Zone
Special Purpose Roads						
Local						
Collector						
Arterial						
Freeway						

Figure 25. Geometric Design Context Framework

### 5.5.1.1 Land Use Context

The more nuanced context definitions better reflect the range of land uses, and most importantly, address the expected presence of and unique requirements associated with pedestrians and bicyclists. Research has established a basis for quantifying the level of activity associated with land use by type and density.

As mentioned in section 3.2.2, the best current model for converting land use into useable context definitions for a geometric design framework is that developed in the Institute of Transportation Engineers (ITE), *Designing Walkable Urban Thoroughfares: A Context Sensitive Approach – ITE Recommended Practice* (25), which is recommended for adoption (Figure 4).

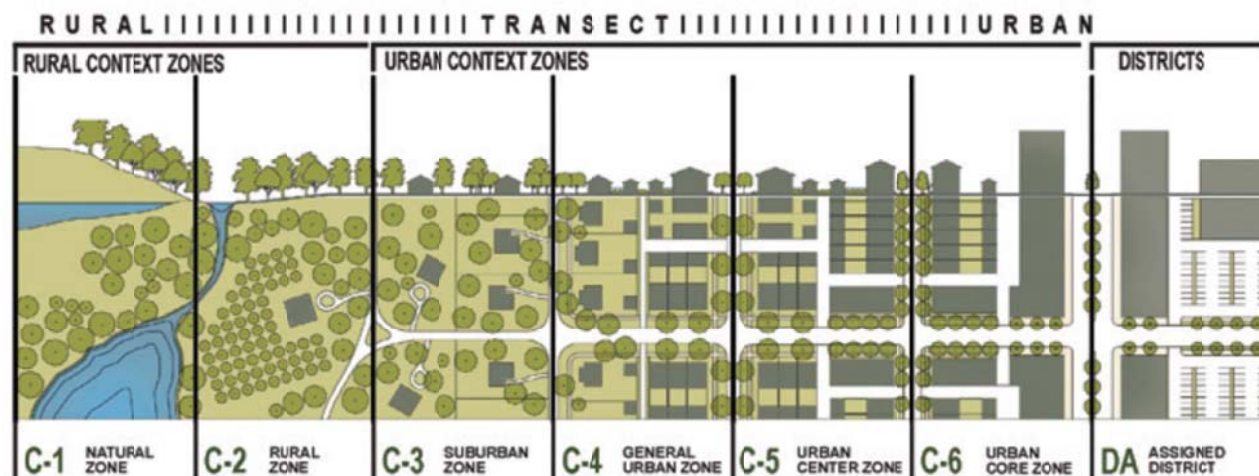

Figure 26. Roadway Context Zones

Source: ITE, *Designing Walkable Urban Thoroughfares: A Context Sensitive Approach – ITE Recommended Practice*

Roads in rural context zones are travelled primarily by motor vehicles. The types, speed regime, and operating conditions will vary based on road type. Two types of rural context zones are proposed, consistent with the ITE Informational Report.

- Rural natural zones are those with highly sensitive and valued environmental features. Road users are made aware of the special nature of the surroundings. Rural natural zones may include national and state parks, national forests, and lands proximate to such lands with similar environmental features. For all road types and functions, geometric design elements are purposely minimized dimensionally to reinforce the primacy of protecting the character of the zone. Travel is mainly by automobile. Bicycle and pedestrian facilities are primarily for recreational purposes.
- Rural general zones are all other areas beyond urbanized jurisdictions. The automobile is still the predominant travel mode. Any developed areas generally have large setbacks not conducive to transit or non-motorized travel.
- Suburban zones are areas in which development, land use, and population density are such that motor vehicles are the primary means of mobility, but the presence of other users (pedestrians and bicyclists) becomes evident and must be considered. Most suburban neighborhoods have sidewalks or paths for pedestrian and/or bicycle travel among the residences, schools, parks and the few commercial uses in those neighborhoods. Design for transit (primarily buses) also may be a design consideration in suburban zones.

Roads in urban context zones include contexts in which land development is relatively dense, but can be varying in nature. Urban areas include residential contexts including single family and multifamily, industrial and commercial districts, office parks, and retail. Zones within the urban context would include consideration of multi-modal users including specifically pedestrians, bicyclists, and transit vehicles (buses).

- General urban zone includes land uses outside the city center, with generally less dense land development. Industrial parks and land activities will be within the general urban zone
- Urban center zone includes primarily higher value, more densely developed land, including multifamily housing, offices, and retail or commercial lands. Limited parking and congestion make automobile travel less efficient. Urban centers are normally served by local bus or rail transit service.
- Urban core zone represents the densest developed lands; The urban core is usually served by long distance buses and trains. Local bus or rail transit is the predominant mode of travel for workers and shoppers for shorter trips in the area, the predominant mode of travel is walking.

Assuming the ITE Context Zone definitions apply, the design framework as described here would include the selection or confirmation of the context zone or zones within which the project exists. In practical terms, this would be predetermined as part of the local or regional planning process conducted by either the owning agency or Metropolitan Planning Organization. Context zone boundaries could be set using objective measures of land use definitions related to their propensity or relationship to generation of non-motorized traffic. Such boundaries should reflect planned future (i.e., formally approved plan) conditions. Stakeholders would confirm the context zone definitions for the project, or revise as necessary based on special conditions.

#### 5.5.1.2 Road Type

Road types generally mirror the functional classes currently used by AASHTO, with some additions. Road types describe the basic purposes of the road. The types of road users and manner in which service is provided varies with the context, which is defined in terms of land use and location.

- Local Roads serve as access to adjoining properties
- Collectors serve as intermediate roadways linking local roads with arterials
- Arterials serve primarily to provide mobility to road users
- Freeways and other Controlled Access Facilities serve longer distance traffic, including specifically freight movement
- Special Purpose Roads serve unique, designated road functions or users. These may be transit only corridors, resource recovery roads, and agricultural roads. Their applicability will clearly vary by land use and location context.

Local roads and collectors will primarily be two-lane roads (serving both directions of travel). Arterials may be two-lane roads in rural context; but in urban contexts these will mostly be multi-lane roads.

Terrain is not part of the framework. Terrain has historically been a surrogate for cost or difficulty of construction, and a simplifying descriptor for dimensional geometric criteria. The geometric design process envisioned employs direct measures of construction or implementation cost, thus eliminating the need for this indirect context descriptor.

NCHRP Project 15-52 is a current active project developing a Context-Sensitive Functional Classification System for More Flexibility in Geometric Design. The objective of this research is to identify potential improvements to the traditional functional classification system to better incorporate the context, user needs, and functions of the roadway facility. The potential improvements should lead to a flexible framework that can be used by planners and designers in the development of optimal geometric design solutions. As of the date of this project's final report, NCHRP Project 15-52 was focusing on a functional classification approach very similar to that presented

here. The AASHTO Green Book Task Force should be able to combine both efforts going forward with little difficulty.

### 5.5.1.3 Geometric Design Framework and Transportation Performance

#### 5.5.1.3.1 Substantive Safety Performance and Land Use Context Zones

The importance of a more robust context zone definition is illustrated in Figure 27. The research team, with permission from the Illinois DOT, performed an analysis of the safety performance of roads in Cook County, Illinois (which includes the City of Chicago) using the context zone definitions in Figure 26 and data from Illinois DoT for the years 2007 to 2009. The downtown core of the City of Chicago was defined as Context Zone 6. Outside the downtown, the remainder of the City was considered Context Zone 4 or 5; and suburban Cook County was considered Context Zones 3, 4, and 5. Labeling of the context zones was based on the research team's knowledge of the area and not a rigorous review per the ITE guidance. The analysis includes characterization of fatal and serious injury crashes (KA) by type of crash (single vehicle or multi-vehicle) and by location (intersection versus road segment). For comparative purposes, data describing crash type characteristics for rural roads (Context Zones 1 and 2) were obtained from default values in the AASHTO Highway Safety Manual (HSM) (18).

The figures show the proportion of crashes by type and the relative frequency of road segment versus intersections for the same context zones, indicated by the areas of the circles.

Within Context Zone 6, the city core, the following is evident:

- Of the 129 KA crashes, 78 (60 percent) occurred at intersections
- A total of 56 percent of intersection crashes and 37 percent of road segment crashes involved vulnerable users
- The next most prevalent serious crash type was multivehicle crashes (40 percent)
- Serious single-vehicle crashes were a small proportion of serious crashes.

The distribution of crash types shows an intuitive trend for other context zones. For areas classified as Context Zones 3 and 4, the proportion of vulnerable user crashes decreases to 16 percent, and the relative proportion of intersection versus segment crashes is closer to 50 percent. Finally, using HSM default statistics for rural context zones, the vulnerable user crashes are negligible, and single-vehicle crashes become more predominant.

This analysis of City of Chicago and Cook County data could be confirmed and further refined using data from other cities and more rigor or objective descriptors of zone definitions. However, it clearly demonstrates the importance and value of a more robust land use definition to apply to the geometric design control task.

Characteristics of Fatal and Injury Crashes by Context Zone -- A Demonstration

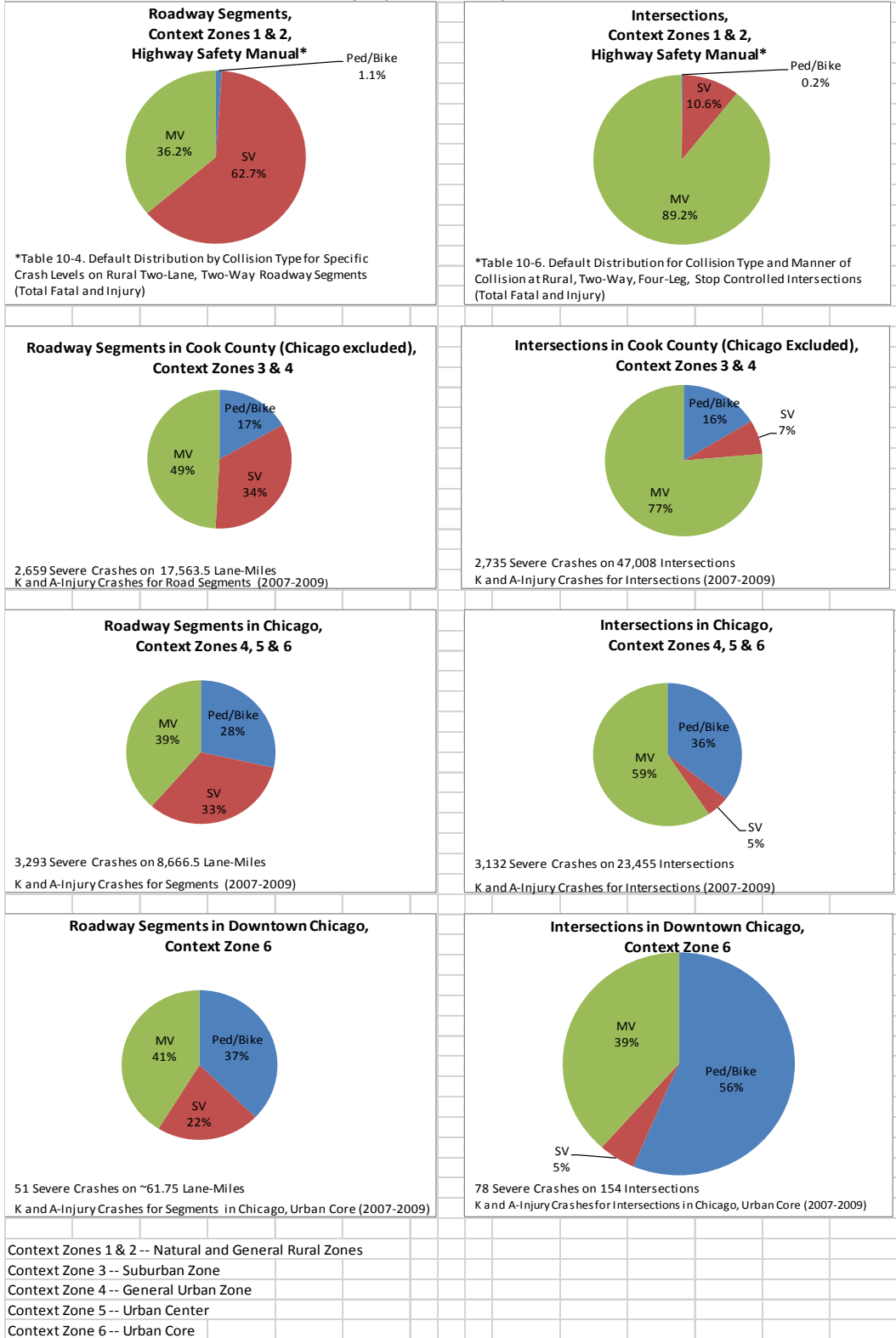

Figure 27. Profile of Fatal and Injury Crashes by Type for ITE Context Zones for Cook County IL

***The substantive risk profile as it relates to road users and crash type throughout the road network is highly sensitive to context. Design policy and process in its formulation and application should be adapted to provide appropriate focus, design controls, dimensions, and approaches that address the unique and differing inherent risks associated with each type of roadway in each of the land use contexts.***

### **Traffic Operational Performance**

Within Context Zones 1 and 2 the primary transportation modes are motor vehicles – both passenger cars and trucks. Context zone 1 may include special vehicle types associated with the nature of the land use. These may include logging or other resource recovery trucks, recreational vehicles including towed carriers for boats and other equipment, and bicycles. Although pedestrians are not excluded, their presence in context zones 1 and 2 is typically of sufficient rarity that their presence does not create special roadway design demands.

Context zone 3 has sufficient development by type and density such that non-motorized road users are present with some regularity. As such, the design and operation of the roadway must consider their presence. In the suburban environment the primary operational concerns remain the movement of vehicles, but 1) transit buses may be present; 2) pedestrians crossing major intersections are a concern; and 3) bicycle traffic may be present, particularly where such routes serve or are adjacent to land uses such as schools and parks.

With context zone 4 land use type and density progress to more urban forms. Pedestrian travel within the right-of-way should be expected, including the crossing of pedestrians at intersections. Intersection frequency may be greater, driveways more prevalent, and in some cases on-street parking common or necessary to support the adjacent land use. Within this context zone buses and trucks also operate, with many of the latter supporting retail and commercial development. Because of the prevalence of pedestrian activity, traffic operations in context zone 4 should emphasize lower speeds to minimize both the frequency and severity of vehicle/pedestrian conflicts.

With context zones 5 and 6, the land use types and density are pure urban form. The street environment serves high volumes of pedestrians. Transit is prevalent and may be the most significant vehicular element. Trucks and freight vehicles are present to serve the commercial land uses, but their operations may be restricted to off peak time periods. Within these context zones, road design issues typically include allocation of cross section and intersection design. Intersection design and operations should favor the safe accommodation of pedestrian travel. This may mean limiting the use of turning lanes, provision for pedestrian only signal phasing, and signal progression that produces very low speeds. Within these zones the concept of LOS for vehicles as classically understood does not apply.

#### **5.5.1.4 Transportation Functions and Road Users in Context Zones**

Figure 28 describes the functional operational needs, values, and road user types associated with each cell in the basic framework. Functionality ranges from accessibility to mobility; with the latter further described by reliability. Road users for which the design should routinely serve range from one vehicle type (for special purpose roads), to motor vehicles only, to the full range of users including vulnerable road users.

Based on the analysis in Figure 27 and other information contained in the AASHTO HSM, a safety performance framework is evident to guide the thought process and priorities of design engineers. This is shown in Figure 28.

Roadway Type	Rural Natural Zone	Rural Zone	Suburban Zone	General Urban Zone	Urban Center Zone	Urban Core Zone
Local	Accessibility to adjacent land uses with minimal cost and environmental disruption		Access to land uses for motor vehicles and vulnerable users		Access to land uses by pedestrians, transit users and bicyclists; access for freight and goods delivery.	
Collector	Mobility and reliability of traffic service (travel time and travel time variance) for reasonable range of vehicle types		Mobility for full range of road users including motor vehicles, bicycles and pedestrians			
Arterial					Travel time reliability for transit buses and taxis; mobility for pedestrians	
Freeway	Minimization and reliability of minimization of total costs of motor vehicle trips of all types (including especially freight), such costs to include both vehicle operating and travel time costs					

Figure 28. Generalized Profile of Typical or Critical Operational Issues Governing Geometric Design by Context

Roadway Type	Rural Natural Zone	Rural Zone	Suburban Zone	General Urban Zone	Urban Center Zone	Urban Core Zone
Local	Single-vehicle Run-off-road (low speed, low frequency)		Multi-vehicle Intersection and driveway-related; pedestrian and bicycle; low speed		Pedestrian -- intersections and mid-block	
Collector			Multi-vehicle Intersection and driveway-related; median and access related			
Arterial	Single-vehicle Run-off-road (high speed, higher frequency); multivehicle intersection-related				Pedestrian -- intersections and mid-block; multivehicle intersection-related	
Freeway	Single-vehicle Run-off-road; truck involved; merging and exiting (interchanges); cross median		Single-vehicle Run-off road; weaving, entering and exiting (interchange related)	Multi-vehicle weaving, entering and exiting; congestion-related rear-end and sideswipe		

Figure 29. Generalized Profile of Typical or Critical Substantive Safety Issues Governing Geometric Design by Context

A land use context zone as part of the geometric design framework would serve to direct the appropriate approach to geometric design based on objective measures of safety performance associated with the full range of road users, and specifically vulnerable users. The selection of appropriate design or target speeds, intersection operating conditions, design vehicles, and design levels of service are influenced by the land use or context definition.

Tables 10A through 10F show such guidance. For each roadway type, the design priorities, speed regime, and influence of the physical context are presented. Priorities are expressed in terms of access and mobility; and safety, with the latter related to the relative frequency of severe crashes.



Table 10. Geometric Design Guidance for Roads and Highways in Rural Natural Zones

	Transportation Design Priorities	Typical Speed Regime	Context Influence on the Approach to Roadway Design
Special Purpose	Generally Not Applicable		
Local	Access for to adjacent properties (employers, residents, delivery vehicles); Safety of pedestrians	20 mph to 50 mph	Maintain character of the natural environment. Cross section (1 or 2-lanes only) and alignment to meet minimum operational requirements of critical design vehicles at very low speeds; 10-ft lanes and nominal shoulders may be used on lower volume facilities
Collector	Access/mobility for motor vehicles; consider needs of recreational bicyclists but separate from travel lanes for motor vehicles	30 to 50 mph based on terrain	Maintain character of the natural environment. Cross section (Maximum 2 lanes) and alignment to meet operational requirements of typical vehicles. Design speed based on terrain (30 mph for mountainous to 50 mph for level)
Arterial	Mobility for motor vehicles passing through including trucks; consider needs of recreational bicyclists but separate from travel lanes for motor vehicles	50 to 70 mph based on terrain	Respect the character of the natural environment; 2 to 4-lane maximum lanes. Employ roundabouts and grade separations and avoid at-grade signalized intersections. Employ 11.5 to 12-ft lanes and full right shoulders; use open medians or barrier medians. Develop alignment that reinforces selected speed limit; design speed based on terrain (50 mph for mountainous to 70 mph for level)
Freeway	Mobility and reliability of mobility for vehicles passing through including trucks	50 to 70 mph based on terrain	Respect the character of the natural environment; employ 12-ft lanes and full shoulders; medians generally open and of sufficient width to not require barrier where possible. Develop alignment that reinforces speed limit and minimizes speed differentials of heavy vehicles; provide interchanges with spacing of 3 miles or more and avoid weaving sections.



Table 11. Geometric Design Guidance for Roads and Highways in Rural General Zones

	Transportation Design Priorities	Typical Speed Regime	Context Influence on the Approach to Roadway Design
Special Purpose	Generally Not Applicable		
Local	Access for to adjacent properties (employers, residents, delivery vehicles); Safety of pedestrians	20 mph to 50 mph	Maintain character of the natural environment. Cross section (1 or 2-lanes only) and alignment to meet minimum operational requirements of critical design vehicles at very low speeds; 10-ft lanes and nominal shoulders may be used on lower volume facilities
Collector	Access/mobility for motor vehicles; consider needs of recreational bicyclists but separate from travel lanes for motor vehicles	30 to 50 mph based on terrain	Maintain character of the natural environment. Cross section (Maximum 2 lanes) and alignment to meet operational requirements of typical vehicles. Design speed based on terrain (30 mph for mountainous to 50 mph for level)
Arterial	Mobility for motor vehicles passing through including trucks; consider needs of recreational bicyclists but separate from travel lanes for motor vehicles	50 to 70 mph based on terrain	Respect the character of the natural environment; 2 to 4-lane maximum lanes. Employ roundabouts and grade separations and avoid at-grade signalized intersections. Employ 11.5 to 12-ft lanes and full right shoulders; use open medians or barrier medians. Develop alignment that reinforces selected speed limit; design speed based on terrain (50 mph for mountainous to 70 mph for level)
Freeway	Mobility and reliability of mobility for vehicles passing through including trucks	50 to 70 mph based on terrain	Respect the character of the natural environment; employ 12-ft lanes and full shoulders; medians generally open and of sufficient width to not require barrier where possible. Develop alignment that reinforces speed limit and minimizes speed differentials of heavy vehicles; provide interchanges with spacing of 3 miles or more and avoid weaving sections.

Table 12. Geometric Design Guidance for Roads and Highways in Suburban Zones

	Transportation Design Priorities	Typical Speed Regime	Context Influence on the Approach to Roadway Design
Special Purpose	Generally Not Applicable		
Local	Access for motor vehicles to designated locations; accessibility and mobility for pedestrians and bicyclists	20 to 35 mph	Limit to 2 lanes; provide on-street parking per land use and local policies; employ minimum lane widths of 10 to 11 ft. Provide all-stop, 2-way stop or mini-roundabout intersections with minimal corner radii for speed control. Employ traffic calming near pedestrian-generating land uses such as schools, parks, churches and libraries. Provide on-street parking on at least one side of the road.
Collector	Access/mobility for motor vehicles; accessibility and mobility for pedestrians and bicyclists	30 to 40 mph	Limit to 4 lanes; provide on-street parking per land use and local policies; employ signalized intersections with arterials. Provide width sufficient for bicycles (either shared use or separate lane); provide for trees and streetscapes as desired with sufficient offsets from travelled way; employ medians for either landscaping or left-turn access based on land use
Arterial	Mobility for all motor vehicles; consider needs of bicyclists; provide for safety of pedestrians crossing at intersections	35 to 50 mph	Employ lane widths of 11 to 12 ft based on speed, volume and large vehicle presence; employ medians with width for left turning vehicles and pedestrian refuge; prefer raised medians where possible given land use and provide median refuge for pedestrian crossings for 6 lanes or more. Discourage on-street parking (provide off-street to support commercial needs); avoid on-street parking along higher speed arterials. Design intersections for reasonably frequent vehicles (transit bus, delivery trucks); signalize to provide progression at desired speeds; provide adequate timing for pedestrian crossing and consider pedestrian lead signals for right turn conflicts; programmatically prohibit right turn on red; design intersections to enable landscaping without conflicting with sight lines.
Freeway	Mobility and reliability of mobility for vehicles passing through including trucks	60 to 70 mph	Employ lane widths of 11.5 to 12 ft; provide full shoulders for incident management. Minimize interchanges to 1.5 mile spacing; avoid weaving sections requiring CD or ramp braids. Favor depressed versus raised cross section for noise and visual effects; Employ efficient service interchange configurations (parclos, DDI, diamonds); adapt interchange design to facilitate pedestrian activity along crossroad; employ traveler information ITS and integrate with adjacent arterial network

Table 13. Geometric Design Guidance for Roads and Highways in Urban General Zones

	Transportation Design Priorities	Typical Speed Regime	Context Influence on the Approach to Roadway Design
Special Purpose	Mobility and Access for special vehicle types (transit buses, pedestrians, bicyclists)	20 to 30 mph	Special purpose defines spatial needs (transit, pedestrian mall, etc.); maintain pedestrian accessibility to adjacent land uses
Local	Access for motor vehicle to designated locations; accessibility and mobility for pedestrians	20 to 35 mph	Limit to 2 lanes with 10 ft widths sufficient; provide on-street parking per land use and local policies; employ minimum lane widths. Provide all-stop, 2-way stop or mini-roundabout intersections with minimal corner radii for speed control. Employ traffic calming near pedestrian-generating land uses such as schools, parks, churches and libraries.
Collector	Access/mobility for motor vehicles; accessibility and mobility for pedestrians and potentially bicyclists	25 to 35 mph	Limit to 4 lanes; provide on-street parking per land use and local policies; employ signalized intersections with arterials. Minimize lane widths -- 11 ft maximum; consider provision for bicycles within travelled way; provide for trees and streetscapes as desired with sufficient offsets from travelled way
Arterial	Mobility for all motor vehicles ; consider needs of bicyclists ; provide for safety of pedestrians crossing at intersections and potentially mid-block	25 to 35 mph	Minimize footprint using 11-ft lanes; employ medians with width for left turning vehicles and pedestrian refuge. Design intersections for reasonably frequent vehicles (transit bus, delivery trucks); signalize to provide progression at lower speeds; provide adequate timing for pedestrian crossing and consider pedestrian lead signals for right turn conflicts; consider prohibition of right turn on red; employ space and design intersections to enable landscaping without conflicting with sight lines.
Freeway	Mobility and reliability of mobility for vehicles passing through including trucks	50 to 60 mph	Favor depressed versus raised cross section for noise and visual effects; consider lane widths less than 12-ft and minimal shoulders to maximize capacity within limited right-of-way; minimize interchanges to avoid weaving sections; use tight diamond and similar configurations and low design speeds for ramps. Generally design for Level of service E

Table 14. Geometric Design Guidance for Roads and Highways in Urban Center Zones

	Transportation Design Priorities	Typical Speed Regime	Context Influence on the Approach to Roadway Design
Special Purpose	Mobility and Access for special vehicle types (transit buses, pedestrians, bicyclists; truck deliveries)	10 to 25 mph	Special purpose defines spatial needs (transit, ped mall, etc.); maintain pedestrian accessibility to adjacent land uses
Local	Access for motor vehicle to designated locations; accessibility and mobility for pedestrians	20 to 30 mph	Limit to 2 lanes; provide on-street parking per land use and local policies; employ minimum lane widths. Provide all-stop, 2-way stop intersections with minimal corner radii for speed control. Employ traffic calming near pedestrian-generating land uses such as schools, parks, churches and libraries.
Collector	Access/mobility for motor vehicles; accessibility and mobility for pedestrians and potentially bicyclists	20 to 35 mph	Limit to 2 lanes; provide on-street parking per land use and local policies; employ signalized intersections with arterials. Minimize lane widths; consider provision for bicycles within travelled way; provide for trees and streetscapes as desired with sufficient offsets from travelled way
Arterial	Mobility for all motor vehicles ; consider needs of bicyclists; provide for safety of pedestrians crossing at intersections and potentially mid-block	25 to 35 mph	Minimize footprint using 10 to 11-ft lanes; employ medians with width for left turning vehicles and pedestrian refuge. Design intersections for reasonably frequent larger vehicles (transit bus, delivery trucks); signalize to provide progression at lower speeds; provide adequate timing for pedestrian crossing and consider pedestrian lead signals for right turn conflicts; programmatically prohibit right turn on red; employ space and design intersections to enable landscaping without conflicting with sight lines.
Freeway	Mobility and reliability of mobility for vehicles passing through including trucks	40 to 50 mph	Favor depressed versus raised cross section for noise and visual effects; consider lane widths less than 12-ft and minimal shoulders to maximize capacity within limited right-of-way; minimize interchanges within urban core to avoid weaving sections; use tight diamond and similar configurations and low design speeds for ramps. Generally design for Level of service E

Table 15. Geometric Design Guidance for Roads and Highways in Urban Core Zones

	Transportation Design Priorities	Typical Speed Regime	Context Influence on the Approach to Roadway Design
Special Purpose	Mobility and Access for special vehicle types (transit buses, pedestrians)	10 to 25 mph	Special purpose defines spatial needs (transit, ped mall, etc.); maintain pedestrian accessibility to adjacent land uses
Local	Access for motor vehicles to designated locations including delivery vehicles; accessibility and mobility for pedestrians	20 mph to 30 mph	Limit to 2 lanes with 10-ft lanes; provide width for curb parking, loading zones and bus stops. Provide all-stop, or 2-way stop intersections with minimal corner radii for speed control.
Collector	Accessibility and mobility for pedestrians and potentially bicyclists; access/mobility for motor vehicles;	20 to 35 mph	Limit to 2 lanes; provide width for curb parking, loading zones and bus stops; employ signalized intersections with arterials. Employ 10-ft lane widths; provide for trees and streetscapes as desired with sufficient offsets from travelled way
Arterial	Provide for safety of pedestrians crossing at intersections and potentially mid-block; mobility for all motor vehicles ;	20 to 35 mph	Minimize footprint using 10- or 11-ft lanes; employ medians with width for left turning vehicles and pedestrian refuge. Design intersections for reasonably frequent vehicles (transit bus, delivery trucks); signalize to provide progression at lower speeds; provide adequate timing for pedestrian crossing and consider pedestrian lead signals for right turn conflicts; programmatically prohibit right turn on red; employ space and design intersections to enable landscaping without conflicting with sight lines.
Freeway	Mobility and reliability of mobility for vehicles passing through including trucks	45 to 55 mph	Favor depressed versus raised cross section for noise and visual effects; consider lane widths less than 12-ft and minimal shoulders to maximize capacity within limited right-of-way; minimize interchanges within urban core to avoid weaving sections; use tight diamond and similar configurations and low design speeds for ramps. Generally design for Level of service E

### 5.5.1.5 Other Land Use Considerations

Another aspect of the land use context is the consideration of specific properties adjacent to, in the vicinity of, or affected by the project. These would include public health and safety sites (hospitals, fire stations, and police stations), schools, public parks, playgrounds and recreational facilities, and places of worship. These may influence the type of design solution, the dimensions of the road, or special operating requirements to be incorporated into the design. For many of these special land uses, pedestrian accessibility is a key feature. The geometric design process, particularly as it relates to development of alternatives and consideration of road user impacts during construction, should include the explicit compilation and analysis of such land uses.

For 3R and reconstruction projects, the accessibility to important public facilities and vice versa will often be critical considerations in maintenance of traffic plan. The geometric design process should include a process step that informs designers of critical land uses. This step should be required regardless of the environmental process applicable to the project. ***Every project should identify, acknowledge, and address changes in access, travel time, or location of public health and safety facilities either permanently or during construction periods.***

Protected lands such as environmentally sensitive wetlands, forests, cemeteries, historically significant properties, and unique local features should be noted and identified as external controls. Regulatory stakeholders and experts in each environmental field are typically the source of information. Information should be of sufficient detail and quality to provide meaningful direction to the designer on the criticality of avoidance versus mitigation per impact.

Roadway designers should be fully briefed on the nature and criticality of such information ***prior to initiating the geometric design process.*** Criticality relates to the type of land use, its quality, the applicable regulations, and the input of the stakeholders responsible for oversight and approvals or permits. Geometric designers also should understand the agency's philosophy and approach to each type of feature or control. Avoidance potentially increases adverse impacts on lands not designated as special in nature. The performance of the road may be adversely affected by pure avoidance approaches (but such an alternative may be necessary to develop and evaluate). Impact and mitigation minimization also are approaches to dealing with important controls.

Some important controls may not be specifically protected by environmental processes, but can be critical to understand. Examples include drainage tiles and flow patterns on agricultural lands, and holders of farm leases (versus ownership) that relate to the patterns of access between properties and their economic viability.

For new alignment or reconstruction projects of any sizable length, there will virtually always be some significant properties or land uses for which the geometric design may be adjusted in three dimensions to avoid or minimize an adverse effect. A central aspect of the geometric design process is the comparison of design solutions that may differ in their effects on adjacent lands, their expected transportation performance, and implementation cost.

## 5.5.2 Develop Project Evaluation Criteria within the Context Framework

Every project regardless of type, size, and problem(s) addressed should be approached from the perspective that there is more than one reasonable design solution. The more complex the problem and the more stakeholders involved, the greater the importance of considering multiple alternatives. Moreover, the more complex the project and number of stakeholders, the greater the chances that adverse effects will be apparent with each design alternative.

***Regardless of project type and context, every road design project requires the designer to assess and manage tradeoffs among important variables of interest to stakeholders and the owning agency.***

A key aspect of the design framework is the set of stated priorities and preferences that will form the basis for selecting a preferred design among many alternatives. This takes the form of project evaluation criteria. The evaluation criteria express the performance and impact tradeoffs involved. Given the location, land use context, project type, and problem(s) being addressed, such criteria should be tailored to the project. Figure 30 shows typical tradeoffs from which performance-based evaluation criteria may be developed to direct decision-making.



Trees along the along the roadside to provide shade and improve aesthetics vs. removing all potential roadside hazards

Inclusion of a left turn lane at a signalized intersection vs. avoid right-of-way taking and/or conflicts with adjacent land uses

Open median or continuous two-way left turn lane to provide access to properties between intersections vs. raised median to control access

Shoulder use on freeways to increase capacity and enhance operations vs. maintenance and emergency use, drainage,

Right turn on red (creating conflicts with pedestrians) vs. reduce delay for right-turning vehicles at signalized intersections

Shoulders on two-lane highways with rumble strips to warn drivers vs. without rumble strips to facilitate shoulder use by bicyclists and/or to avoid noise impacts from shoulder encroachments

Use of permissive only signal phasing vs. protected signal phasing for left turn lanes at signalized intersections

3:1 side slopes vs. 4:1 or flatter to reduce construction costs

*Figure 30. Typical Spatial and Operational Tradeoffs in Geometric Design*

Evaluation criteria are categorized in one of the following areas:

- Construction or implementation cost and time (including relevant M&O costs)
- Right-of-way (separate from cost of right-of-way; may include amount, type, and relocations)
- Traffic operations
- Public Safety
- Environmental effects

Evaluation criteria can include prohibitions or “fatal flaw” attributes; or can include specific requirements. These may be associated with requirements of regulatory agencies (including specifically environmental agencies) or significant preferences of key stakeholders involved with the project. The criteria should be stated in quantitative terms relevant to the project size and scope and problems being addressed. Appendix A is a performance criteria memorandum developed for a project involving the replacement of a river bridge. The criteria specify the threshold values, means of measuring, and relative importance of each.

Agency assurances that a particular stakeholder preference will be addressed or accommodated are policy decisions. The agency bears the responsibility of defending or explaining their assurances, and demonstrating they understand the trade-offs or impacts borne as a result of the accommodation. In the interests of transparency, agencies should reveal such assurances and provide relevant data or substantive reasons for such assurances that demonstrate their relative value as part of the overall evaluation criteria. Indeed, in some cases

meeting a stakeholder concern may be part of the core defined transportation problem (e.g., maintaining full accessibility to property x).

It has historically been common practice for evaluation criteria to be developed by agency design engineers after the initial development of design alternatives. ***The improved geometric design process calls for this step to be conducted prior to design project development.*** This is for two important reasons. First, awareness of the criteria serves to direct the work flows, data and analysis processes, and level of detail in the alternatives development stage. The criteria also provide focus to the designers by informing them of what constitutes success. Second, the design team avoids the potential perception of bias from external stakeholders, which may occur if evaluation criteria are developed after alternatives development. For complex design projects involving multiple tradeoffs, it is pointless to begin design without first arriving at a common point of reference or consensus around what constitutes an optimal design solution. An optimal design solution implies a solution consistent with the priorities established for and constraints present within the project.

The evaluation criteria should be objectively stated, uniquely defined, and tailored to the project. Qualitative or subjective measures should be avoided in favor of specific, numeric, or objective measures. They may include criteria that relate to just one portion or segment of the project (e.g., an intersection or curve). The importance of the evaluation criteria should be expressed (i.e., what are the most important factors driving the final decision). The process where criteria may be weighted and formal processes for calculating an optimal project score established is known as Multi-attribute Utility Analysis and is used by some agencies to inform decision making (2).

Relatively small or straightforward projects will involve design choices and tradeoffs. A 3R project that involves addressing a pavement condition problem may include analysis of different pavement types and pavement designs, each of which may produce differences in vertical alignment and drainage, length of time to construct, useful service life, and total initial construction costs.

Depending on the project, the criteria and weighting should be developed through consultation with stakeholders, typically in one or more workshop settings. As a minimum, the criteria should be shared with stakeholders so they understand the basis on which the decision will be reached.

### 5.5.3 Establish Decision-making Roles and Responsibilities

Stakeholders and project staff need to understand who is making the significant decisions, including the selection of the preferred geometric design. Confirmation and communication of the decision maker(s) should be specific, and not just the DOT as there are many types of projects that involve different levels within the organization. For some projects, the agency's project manager or lead engineer may make the decision; for others the local or district engineer may make the ultimate decisions; or the decision may rest with the agency's senior management.

Highway engineering staff responsible for the geometric design of alternatives may not be the final decision makers on projects, particularly more complex ones. Engineering staff must be fully aware of the constraints, values, and the evaluation criteria that define success. They should fully understand the policies of their agency, promises to external stakeholders, and the agency's overall program and resources. Agency leadership will rely on the technical skills and creativity of the highway engineering staff to develop the solutions that best meet project needs and respect the community values. This knowledge and understanding should be reached prior to initiating project alternative designs.

External stakeholders may serve in a consultation or advisory role. Some project decisions may involve the stakeholders directly. Project issues that affect the operation or performance of another agency's infrastructure should include that agency. Everyone's role and responsibility should be confirmed at the project outset.

## 5.5.4 Determine Basic Geometric Design Controls – Design or Target Speed

Geometric design controls involve those technical inputs that will directly or indirectly control the type and nature of the design. Many of these controls will be directed by the context (described above) and project type. However, an effective geometric design process is one that provides designers with choices in the controls to be used.

The importance and necessity of speed as a direct input to roadway design is confirmed. The geometric design process will require speed input as a means of developing design criteria, selecting appropriate design features, and establishing traffic control. For contexts in which design speed applies, the selection of an appropriate design speed is a control that a designer should have a range of speeds from which to select.

The original concept of design speed dating to the 1940s was that it was independently developed by the designer. The legal posted speed, which historically was set by traffic engineers, was typically associated with an 85<sup>th</sup> percentile observed free speed. It has become common practice now for posted speeds to be set by governmental policy or even legislation, outside of an engineering analysis of speed behavior or roadway context. Moreover, an outcome of the outdated AASHTO design policies for horizontal alignment is that the original relationship between the 85<sup>th</sup> percentile speed and design speed no longer holds true irrespective of posted speed limits.

Given AASHTO's definition of design speed there is no substantive reason why design and posted speed need to be linked. Indeed, under the current design process and methods for determining alignment and sight distance, the linking of the two creates conditions in which the road design encourages higher speeds than are desired or appropriate (Tables 4A through 4F). However, the legacy of the term and its direct linkage by policy of FHWA and many DOTs may preclude changes to such policies.

ITE adopted the term target speed in its *Designing Walkable Urban Thoroughfares: A Context Sensitive Approach – ITE Recommended Practice* (25). This term may be useful in expressing the desired speed outcome of a geometric design solution for which a speed metric is needed to determine a physical dimension. The geometric design process could utilize available tools to predict speeds, and the body of literature on speed effects of treatments or designs (e.g., traffic calming devices or narrowing of roads) to test and refine a design to produce the desired target speed for the specific context.

It is clear that some measure or uses of speed in the development and application of design criteria should remain within a revised design process. However, what is needed is a more nuanced approach to speed that is sensitive to road type and context. A revised design process should emphasize and promote the following:

- Speeds appropriate for both driver expectations and the context, with the latter defining a full range of speeds
- The de-linking of design speed with quality, which translates to how to provide high-quality design approaches in the urban environment for which lower speeds are appropriate
- The inclusion of measures of speed related to crash risk, including speed differentials and speed changes
- Full consideration of terrain and land use (i.e. selecting a practical design speed)

Design policy should avoid communicating the concept that design speed is a surrogate for design quality; and that promotion of higher speeds regardless of context will often produce undesirable performance (not to mention higher cost). In urban contexts where pedestrians are prevalent, designing a road to meet the desires of drivers to operate at higher speeds increases vulnerable user crash severity risk.

Another design policy challenge is the institutionalized relationship between the design speed and posted speed. As originally developed, the concept of design speed was selected based on the AASHTO context (urban/rural; terrain); and the geometric design would produce driver behavior consistent with the design speed and codified through speed studies in setting posted speed limits.

Over the past 40 years, both the outdated nature of alignment policy model assumptions and the injection of public policy into setting of artificially low speed limits has made the initial concept of design speed unworkable, to the extent that common practice is now to set a design speed based on what the current law or policy says what the posted speed limit is or should be.

Finally, the concept of design speed as originally developed was rural centric. The alignment and cross section of roads in urban and suburban areas has little influence (except in unusual, extreme cases) on speed behavior. Rather, it is the presence, frequency, and spacing of intersections, and in particular signalized intersections, that influence speed and speed behavior.

#### 5.5.4.1 Design or Target Speed and Road Geometry

Speed currently directly influences horizontal alignment design, vertical curvature (through application of stopping sight distance, which is based on speed), intersection sight distance (ISD), and roadside design.

##### 5.5.4.1.1 Design or Target Speed Regime – Urban non-freeway roads

Roads and streets in urban contexts should be designed and operated to serve multimodal traffic within the right-of-way. A primary safety performance concern in all urban land contexts is the exposure of pedestrians to crashes. The second most important safety concern is the crossing conflict associated with intersections, operated in a variety of ways.

A design process with a basis of overall safety performance should be centered on the development and application of design criteria in a moderate to low-speed environment. The general urban, urban center, and urban core zones are characterized by fully developed land use, and 6 to 10 intersections occurring per mile, with intermittent driveways in some cases. The following is evident:

- The concept of stopping sight distance (stop to avoid an object in the road) is functionally irrelevant in this environment. Sightline-related conflict avoidance primarily concerns crossing conflicts at intersections and driveways, such conflicts to include pedestrians and bicyclists. Drivers essentially navigate from one intersection to the next. For residential streets and those adjoining parks and similar spaces, consideration should be given to providing stopping sight distance for pedestrians in the street.
- Posted speed limits will usually be at most 40 mph, and often 30 to 35 mph for non-freeway road types.
- The concept of providing for clear zones has limited application in roadside design for urban roads. Consequently, there have been changes in the 2011 AASHTO Policy. Right-of-way outside the edge of the pavement is limited, often to less than 10 feet. Curbs create the potential for vaulting and loss of control when struck. Fixed objects such as roadside furniture, light and utility poles, and trees will be within 5 feet, and pedestrians will often travel within 5 feet of the edge of pavement. Despite these conditions, the relative risk of serious urban single vehicle crashes is much less than other crash types precisely because of the lower prevailing speeds (Figure 26).
- There is generally insufficient space to allow for transition from roadway elevations and adjacent driveways, walkways, making it important for the vertical alignment of the road to match the adjacent terrain.
- The concept of providing an alignment that is comfortable to travel at some speed when unimpeded by traffic does not apply.
- Visual distractions to drivers from signs, lights, and activities are typically numerous and continuous

For the urban environment, a context-sensitive design process that incorporates speed in relevant ways should focus on sightline conflicts and sight distance. The following is suggested:

- By policy, all non-freeway roads within each defined urban context zones would be designed to a single or small range of speed. The selected speed would be sufficiently high to produce appropriate calculations of sight lines for all forms of ISD.

- The only application of this speed on the road geometry would be in determination of sight distances, which would be intersection sight-distance related. Design controls for horizontal and vertical alignment would be based on vehicle operational limitations independent of speed and provision for drainage.

Table 16 shows an example set of design or target speed guidelines applicable to urban context zones.

Table 16. Target Speeds for Urban Context Zones by Highway Type

Non-freeway Urban Context Speed Regime*			
	General Urban Zone	Urban Center Zone	Urban Core Zone
Local	35	35	35
Collector	35	35	35
Arterial	40	40	40
*Speeds for design of intersection sight distance only			

#### 5.5.4.1.2 Design or Target Speed Regime – Rural non-freeway roads

The use of a speed metric for rural roads appears necessary. The relationships between crash severity and speed, and between user operating costs and speed, both support speed as a vital metric. How speed is actually applied to alignment and sight distance design may differ from current policy.

### 5.5.5 Determine Basic Design Controls -- Design Traffic Volumes

The design process being inherently forward-looking, all projects are designed based on a projection or forecast of future traffic. Design year traffic directly influences pavement design, sizing of the roadway and intersections, and may influence roadway geometry. Design year traffic forecasts should be developed and applied in a manner consistent with the current best practices and methods for safety and operational analysis. Under current practices this means as a minimum average annual daily traffic (AADT), design hour volume (DHV), vehicle classification (T percent) and turning movement counts and DHV for intersections.

For many higher volume roads in congested contexts, additional basic data may be necessary to enable complete evaluation of a geometric design. Peak hour traffic has historically served as the basis for sizing decisions. Traffic analyses to support design decisions or differentiate among alternatives have focused on operations during the peak hour or hours. In most major cities, however, it has long been impractical, and is now considered poor public policy, to even attempt to design to meet the demand represented by peak hour traffic. As designing for LOS E becomes commonplace, additional traffic parameters and metrics or approaches have become necessary to fully understand and differentiate among alternatives.

The geometric design process relies on transportation planning subprocesses that forecast vehicle traffic volumes based on future land use, road network characteristics, and research on human behavior and response to travel choices. Forecasts reflect the socioeconomics and major policies of the jurisdiction in the future. *Weekday traffic distribution* data describing the variation in demand across a 24-hour day are a necessary basic traffic volume input to design. Many metropolitan planning organizations no longer forecast average daily traffic, but rather peak hour traffic, or even traffic throughout a typical 24-hour weekday. For example, Figure 30 shows the modeling approach used by the Metropolitan Planning Agency for Chicago, which involves the forecasting of demand volumes for eight time periods within a typical weekday. The development of traffic forecasts of multiple

time periods for design purposes, or for operational analyses in alternatives consideration, may be appropriate for certain project types or contexts.

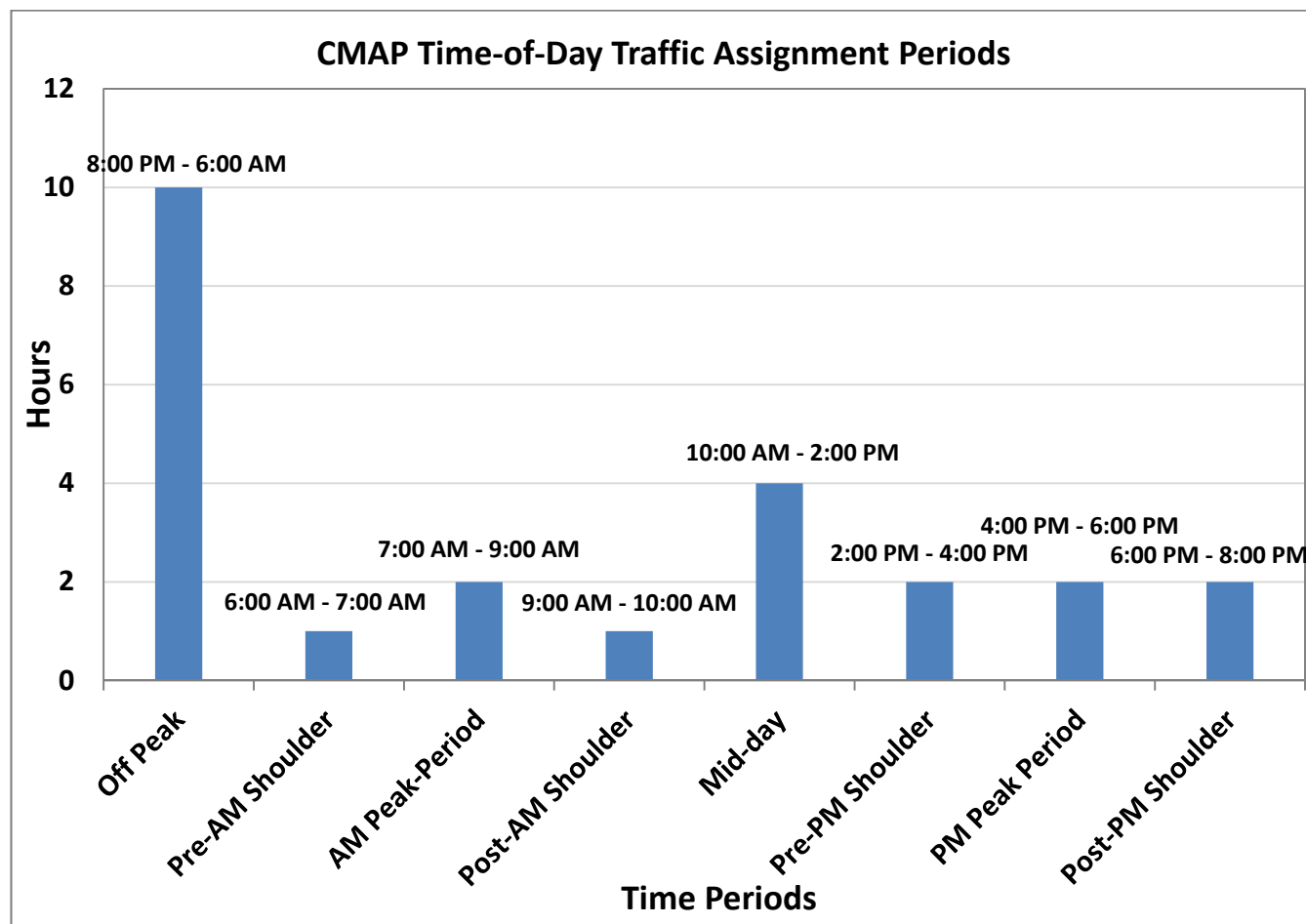

Figure 30. Traffic Assignment Periods Employed by the Chicago Metropolitan Agency of Planning (CMAP)

Transportation agency planning policies will generally establish both a timeframe and basis for design year traffic, with certain parameters not subject to judgment or choice. These would include average daily traffic and percentages of heavy vehicles, which are used in pavement design. Other parameters may involve a technical or policy decision by the designer or agency. Certain roadway features are designed based on hourly traffic volumes, with the DHV selected to represent a critical threshold for design purposes. This number, expressed relative to the annual distribution of hourly volumes, may be influenced by historic count data, but the selection of the hourly basis is a choice that should reflect the road type and context. For example, an hourly volume representing the 30<sup>th</sup>, 50<sup>th</sup>, 100<sup>th</sup>, or 200<sup>th</sup> highest volume for year may be the basis for design. Designers may select and test more than one hourly volume, particularly in urban areas where design for congestion is necessary, or for roadways serving highly peaked or recreational traffic.

The forecast data become direct inputs to fundamental geometric design decisions as illustrated below:

- Basic number of through lanes reflects design year average daily traffic
- Intersection traffic control reflects peak period approach and turning traffic
- Intersection channelization (number of left- and right-turn lanes) reflects peak period approach and turning traffic
- Intersection channelization (lengths of turn lanes) reflects approach volumes and signal cycle lengths that are related to speed, phasing, and other operational parameters

- Warrants for grade separations or interchanges reflect crossing average daily traffic
- Roadside design criteria and policies are based on average daily traffic
- Minimum cross section dimensions may be based on average daily traffic
- Crosswalk and pedestrian signing treatments reflect average daily traffic

Forecast traffic volumes also form the basis for estimating quantitative benefits of design solutions. Operating costs, travel time, and crash costs are directly related to the volume of vehicles (and persons) using the roadway. Evaluation methods and models may employ hourly volumes or daily volumes. The HSM methodologies are currently based on AADT values; with additional data necessary such as the number of hours per day that lane volume exceeds 1000 vehicles per hour for freeway safety predictions. Use of such tools requires 24-hour weekday distribution data. To summarize, a revised geometric design process requires that sufficient detail and specificity be developed in forecast traffic, consistent with the operational analysis methods representing best practices.

#### 5.5.5.1 A New Parameter – Service Life Traffic

An historic anomaly of the geometric design process is the disconnect between the nominal forecast design year (typically 30 years or less) and the expected useful physical life of roadway infrastructure. Right-of-way, road grading, storm sewer, and structural elements have practical service lives of 75 years or more. A current trend in pavement design is for longer-lasting pavement – up to 50 years or more. Major river crossings such as tunnels or long span bridges are designed assuming at least 100 years of life. These much longer functional lives conflict with the much shorter timeframes for which design year traffic is typically developed. To summarize, the sizing and geometric design of roads is commonly based on a level of traffic (and hence intended performance) far short of that compared to the expected life of the physical infrastructure.

The recommended geometric design process incorporates the full life cycle of a project as defined by the functional performance of the project's infrastructure for as far as is reasonable to estimate. Roadway infrastructure provides measurable benefits and requires the incurring of real costs, well beyond a 20 to 30 year nominal design life.

A new service life traffic design control is proposed to enable the estimation of these benefits and costs beyond the nominal design year as part of the geometric design process. Service life traffic volume would be an annual traffic volume considered appropriate for analysis purposes to represent the operations of the roadway at a time period consistent with the intended physical service life of the roadway infrastructure. The application of service life traffic is:

- Based on the project type, designers (or agencies by policy) would assign a service life to the project. Table 17 presents a set of guidelines that would reflect the nature of the construction and context. Longer service lives are associated with newly acquired right-of-way, new bridges, and new major infrastructure such as tunnels or major river crossings. Shorter service lives may be associated with bridge repair, replacement of pavement (reconstruction), and projects that do not include new right-of-way or utility relocations. Figure 31 demonstrates the relationship between the typical agency costs and the transportation benefits through the service life of the facility. The transportation benefits increase over the years as the traffic volume served by the facility increases. The agency costs for maintenance increase as the facility gets older. Periodic costs for rehabilitation costs will be incurred over the life of the facility.

Table 17. Guidelines for Assignment of Service Life for Roadway Infrastructure Projects

Project Type	Recommended Guidance for Service Life of Roadway Infrastructure
<b>3R (Pavement Resurfacing)</b>	<b>20 to 30 years</b>
<b>Roadway Reconstruction</b>	<b>75 to 100 years</b>
<b>New alignment roadway</b>	<b>75 to 100 years</b>
<b>Bridges, walls and related infrastructure</b>	<b>50 to 75 years</b>
<b>Major Watercourse Crossings</b>	<b>100 years</b>

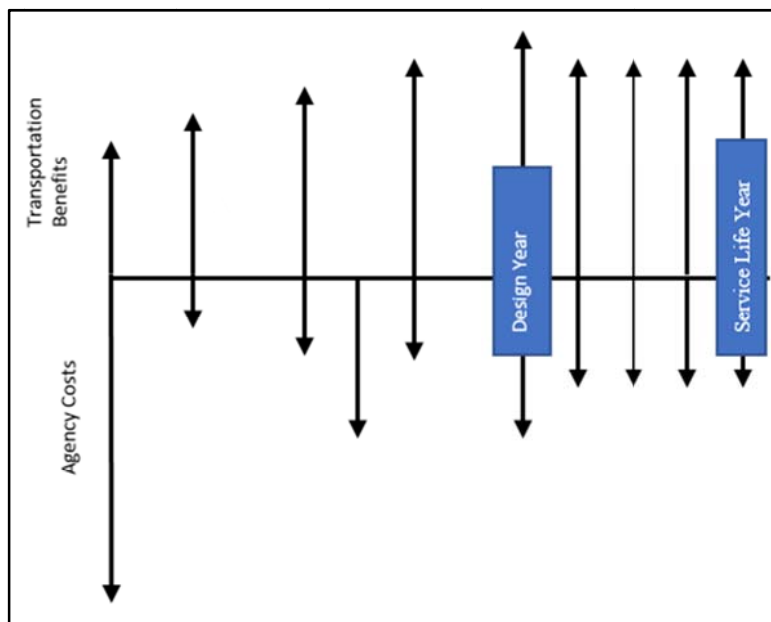

Figure 31 Agency Costs - Transportation Benefits

- Service life traffic volumes would be developed to be used in cost-benefit analyses. Such volumes would not be forecast in the traditional sense, as the premise in service life volume is that the applicable timeframe is beyond that for which travel forecasts can be reliably made. Rather, the traffic volumes would be set by agency policy to reflect an operating set of assumptions considered reasonable by the agency for the purpose of calculating or estimating societal travel benefits. Depending on the project and context, a number of reasonable approaches may be taken. These may include: 1) holding design year traffic constant from the design year to the end of service life; 2) extrapolating traffic growth at the same rate as the ratio of design year to current year traffic implications; 3) extrapolating traffic growth at some rate between no growth and that growth implied by the ratio of design year to initial year traffic.
- Calculation of benefits (safety, traffic operations, time, and delay) and costs (O&M) sensitive to traffic volume would be made assuming the service life traffic volumes beyond the design year to the service life year.
- A terminal life also could be assumed at the end of the service life. This may include the value of the right-of-way and road grading, and some portion of major bridge infrastructure.



Careful thought and judgment is necessary to develop reasonable service life traffic volumes. Some additional thinking and research may be appropriate. Yet, the notion that highway projects provide meaningful benefits and produce ongoing costs beyond the nominal design year is correct. A geometric design process reliant on principles of cost-effectiveness and financial sustainability must include consideration of these benefits and costs.

The relative importance of capturing costs and benefits beyond the design life will depend on the discount or interest rate used in the analysis. In financial environments in which low interest rates prevail, calculated cash flow benefits and costs will be meaningful for 50 years or more. Current U.S. Federal Office of Management and Budget guidance for federal infrastructure cost effectiveness analysis using constant dollar (no inflation) values calls for a discount rate of 1.9 percent for 30 years (26). Typical discount rates in the range of 2 to 4 percent will adjust for the inherent uncertainty associated with forecasts beyond 30 years.

### 5.5.6 Determine Basic Design Controls – Design Level of Service (or Operating Condition)

Current design practice applies the concept of levels of service to the roadway design. Such levels of service are defined and their basis for application described in the 2010 Highway Capacity Manual (HCM) (27).

LOSs range from A to F. The definition of LOS and its calculation varies with the type of road and, in some cases, feature of the road (Figure 33). Under current design practice a roadway is sized and designed to provide the selected LOS using the appropriate methodologies per the HCM (for road segment type, intersection, ramp terminal, roundabout).

LOS is a design control that is the choice of the designer or agency. Current design policy in the AASHTO Green Book provides guidance, but the text and intent of the policy is for this to be a choice. An effective design process requires methods that use meaningful and understandable measures of transportation performance.

The historic design process uses design hour traffic and LOS merely for sizing purposes. Also, it may be used in other evaluations such as air quality and noise calculations. Design hour traffic also is used to develop performance measures for delay, fuel consumption, and other metrics using microsimulation programs such as VISSIM and CORSIM.

The concept of reliability has been developed and is now included in the HCM as an additional attribute or control in traffic operations. Chapters 36 and 37 of the HCM present methods that can be used to describe how often particular operational conditions occur and how bad conditions can get. The framework proposed here can incorporate reliability measures to the extent that they can be translated into operational performance measures (travel time, operating cost, and crash costs).

System Element	HCM Chapter	Service Measure(s)				Systems Analysis Measure
		Automobile	Pedestrian	Bicycle	Transit	
Freeway facility	10	Density	--	--	--	Speed
Basic freeway segment	11	Density	--	--	--	Speed
Freeway weaving segment	12	Density	--	--	--	Speed
Freeway merge and diverge segments	13	Density	--	--	--	Speed
Multilane highway	14	Density	--	LOS score <sup>a</sup>	--	Speed
Two-lane highway	15	Percent time-spent-following, speed	--	LOS score <sup>a</sup>	--	Speed
Urban street facility	16	Speed	LOS score <sup>a</sup>	LOS score <sup>a</sup>	LOS score <sup>a</sup>	Speed
Urban street segment	17	Speed	LOS score <sup>a</sup>	LOS score <sup>a</sup>	LOS score <sup>a</sup>	Speed
Signalized intersection	18	Delay	LOS score <sup>a</sup>	LOS score <sup>a</sup>	--	Delay
Two-way stop	19	Delay	Delay	--	--	Delay
All-way stop	20	Delay	--	--	--	Delay
Roundabout	21	Delay	--	--	--	Delay
Interchange ramp terminal	22	Delay	--	--	--	Delay
Off-street pedestrian-bicycle facility	23	--	Space, events <sup>b</sup>	LOS score <sup>a</sup>	--	Speed

Notes: <sup>a</sup> See Exhibit 2-3 for the LOS score components.  
<sup>b</sup> Events are situations where pedestrians meet bicyclists.

System Element	HCM Chapter	Mode	Model Components
Multilane and two-lane highways	14, 15	Bicycle	Pavement quality, perceived separation from motor vehicles, motor vehicle volume and speed
Urban street facility	16	Automobile	Weighted average of segment automobile LOS scores
		Pedestrian	Urban street segment and signalized intersection pedestrian LOS scores, midblock crossing difficulty
		Bicycle	Urban street segment and signalized intersection bicycle LOS scores, driveway conflicts
		Transit	Weighted average of segment transit LOS scores
Urban street segment	17	Automobile	Stops per mile, left-turn lane presence
		Pedestrian	Pedestrian density, sidewalk width, perceived separation from motor vehicles, motor vehicle volume and speed
		Bicycle	Perceived separation from motor vehicles, pavement quality, motor vehicle volume and speed
		Transit	Service frequency, perceived speed, pedestrian LOS
Signalized intersection	18	Pedestrian	Street crossing delay, pedestrian exposure to turning vehicle conflicts, crossing distance
		Bicycle	Perceived separation from motor vehicles, crossing distance
Off-street pedestrian-bicycle facility	23	Bicycle	Average meetings/minute, active passings/minute, path width, centerline presence, delayed passings

Figure 32. Level of Service Definitions for Road Types (Source: HCM Exhibit 2-2 and 2-3)

### 5.5.7 Determine Basic Design Controls – Road User Attributes

Multimodal road users include all motor vehicle types (passenger cars, buses, trucks, and special vehicles such as emergency service, agricultural, or resource recovery), bicyclists, and pedestrians.

#### 5.5.7.1 Design Motor Vehicles

The design vehicle is that vehicle or vehicles that may be legally operated on the roadway; and have physical and/or operating characteristics more critical than other vehicles, and should be used to control the design of the relevant geometric element.

- Width (feet) – lane width, shoulder width
- Turning radii and off tracking (feet) – corner radius, offset, width of turning roadway
- Center of gravity (feet) – propensity to overturn at a combination of speed and curvature

- Height of eye (feet) – Sight distance
- Acceleration (feet/second/second) – Length of speed change lanes
- Gradability (wt/hp) (maximum speed on grade by length)
- Length (feet) – queue lengths

### 5.5.7.2 Design Driver

AASHTO Policy has developed and applied the concept of a ‘design driver’ for many years. In its traditional form, the design driver is one considered to be of sufficient minimal capabilities to legally operate a motor vehicle. The design driver is sober (not under the influence of drugs or alcohol). The design driver per AASHTO is one with a 95th percentile ability to react to external stimuli by applying the brake and/or steering to avoid a conflict. The design driver has sufficient capabilities to see and perceive the roadway and its environs. Human factors research has historically been applied to establish basic driver inputs to design, e.g., perception and reaction time; unsignalized intersection gap acceptance, and navigational or decision time.

In addition to the above basic design driver attributes, there are other relevant attributes that describe the range of driver response to roadway situations. These may include driver response to traffic signal changes (‘yellow deceleration rate,’ speed selection, car-following and headway acceptance, merging gap acceptance and acceleration selection, and passing behavior. Some of this behavior is regional in nature, and some demographic (e.g., elderly drivers).

Both the knowledge base and traffic operational technology now in practice allow for the highway designer to adjust a design, or to evaluate the operation of a design based on a range of potential driver behavior scenarios. Agency design standards may be based on less aggressive or more ‘conservative’ driver assumptions, but different driver profiles in practice may produce different operations. The software currently available for the evaluation and simulation of traffic operations enables selection of various driver types. One commonly used proprietary software package allow selection of as many as ten different driver types based on 14 input parameters.

### 5.5.7.3 The Design Bicycle

In some contexts and road types, design for bicyclists is a potential design control. The operational requirements for bicycles would control the geometric design of bike paths. Where bicycles operate within the roadway used by motor vehicles, two elements may be influenced by the operation of bicycles:

- Width (feet) – shared lane width, bicycle lane width
- Gradability (combination of grade and length traversable by cyclist)
- Physical separation and/or barrier to provide protection from higher speed vehicle traffic

### 5.5.7.4 The Design Pedestrian

For certain contexts, the operating needs of pedestrians may control the geometric design of roadway elements. The relevant characteristic is walking speed (feet per second). Walking speed translates to the minimum crossing time at a signalized intersection. Elderly and disabled pedestrians travel at slower speeds, and pedestrian walk times in inclement weather are slower. Designers would select a walking speed compatible with the demographic characteristics of the area and climate.

An updated design process also should include the identification of where and how the presence of pedestrians is of sufficient importance to directly affect the geometry or operation of the road. This may be set by agency policies, for example, linked to land use context; based on counts or estimates of pedestrians, and/or proximity to specific land uses. Pedestrian presence as a design control may influence selection of the design vehicle and design radii for intersections, islands, channelization, median widths, a design assumption of no right turn on red, pedestrian phasing, and signal-cycle assumptions.

### 5.5.7.5 Non-motorized Traffic Operational and Design Controls

In some land use contexts, the presence of pedestrians and bicyclists becomes an explicit design control. The geometric design process may require counts or estimates of bicycle volume, pedestrian volumes, and pedestrian walking speeds. The presence of transit routes, designated stops, and arrival headways also may be controls.

For urban core context zones or their equivalent, explicit operating controls for intersection design may be considered either as agency policy or on a project specific basis, such controls to influence the road design.

Following is a sample list of the controls, and it may include any or all of the following:

- Prohibition of right turn on red at signals (to facilitate pedestrian crossing)
- Pedestrian only phasing and/or all-red pedestrian only lead phasing
- Cycle length to accommodate progression for certain movements
- Provision for (or preclusion of) pedestrian crosswalks
- Lane widths of 10 feet preferred (to minimize pedestrian crossing distances and promote lower speeds of traffic)
- City bus or single unit truck assumed for intersection design
- Small corner radii to slow turning traffic and increase queuing space for pedestrians at intersections
- Raised medians for streets with more than six lanes (three each direction) to facilitate pedestrian crossings
- Space for transit stops (near side or far side) within intersections

Setting these as design controls will translate directly to geometric elements such as lengths of left- and right-turn lanes (produced by queuing behavior), radii at intersections, total width of the roadway, and others.

## 5.6 Step 6 -- Apply the Appropriate Geometric Design Process and Criteria

Under the proposed geometric design process there would be unique published geometric design criteria and processes applicable to the project as defined by its type and problem being addressed. Figure 34 demonstrates the simple decision-tree for the types of design criteria envisioned. The process is based on the aforementioned unique aspects of projects as defined by type and the problem being addressed.

Figure 34 illustrates the process using the covers of core documents including the HCM, HSM, and AASHTO Green Book. The intent is not to specifically call only these documents out, but rather to demonstrate that the geometric design process will include not only published dimensional criteria, but will rely on methodologies, tools, and best-practice information that characterize the operational and substantive safety effects of geometric elements and their dimensions.

This simple diagram outlines a decision framework focusing on the type of project and nature of the problem or issue being addressed. Both the design process and applicable design criteria differ based on the applicable approach. (The possibility that multiple problems may exist is acknowledged. For the purposes of outlining the basic philosophy and approach, consider that the process would be driven by the problem that is most central or critical to the project's programming and budget allocation.)

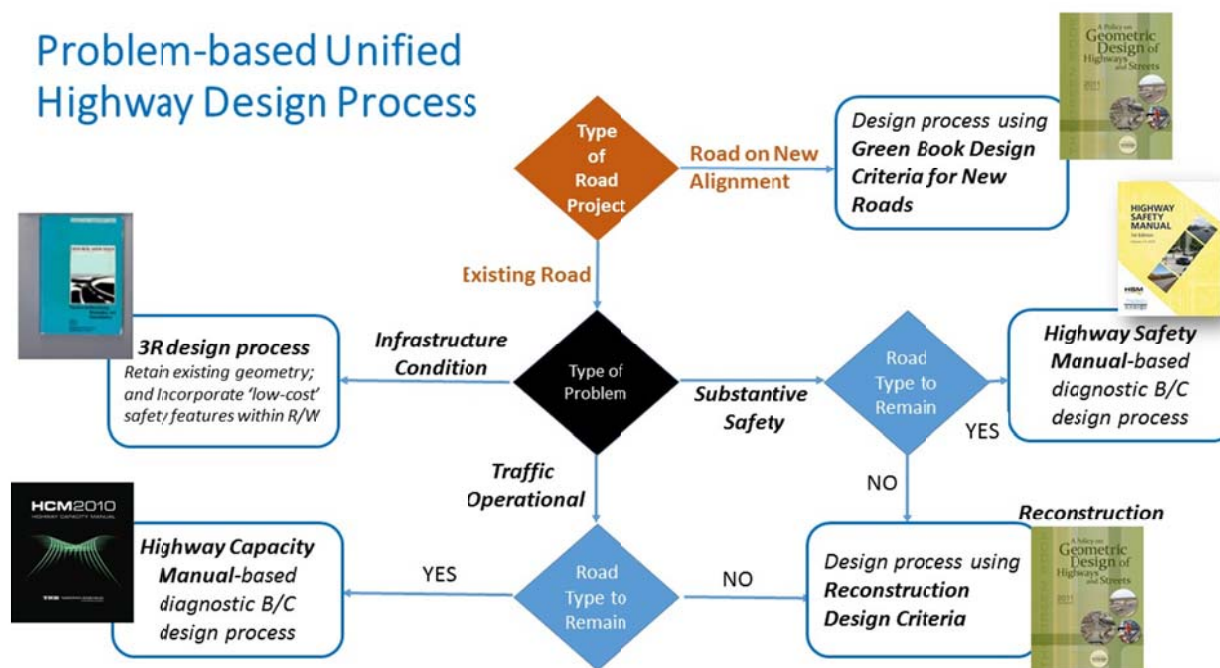

Figure 33. Problem-based Unified Geometric Design Process

### 5.6.1 Roads on New Alignment Are Designed with a Unique Process and Criteria

The decision-tree of Figure 34 shows two initial possible paths based on the type of project. A road on new alignment would be designed in accordance with a revised AASHTO Green Book for Roads on New Alignment or its equivalent. The geometric criteria in this Green Book would be updated to reflect operational and safety relationships and cost-effective principles, including the incorporation of traffic volume in formulation of criteria for the full range of cross section, alignment, and sight distances. The derivation of the criteria would be based on cost-effective approaches using the concept of service life. Section 3 of this report provides an overview of recommended approaches to revising AASHTO criteria for new roads.

Designers would use other references and tools such as the HCM and HSM as they are used today, to size the roadway and test and compare alternative designs. Revised design criteria reflecting context, sensitivity to measurable performance outcomes, and traffic volume would be developed with greater depth and potential important differences based on context compared with the current Green Book's contents

### 5.6.2 Design of Projects Involving Existing Roads

The second major path in the decision tree is for an existing road. Here, the geometric design process proceeds based on the type of problem(s) that are behind the reason for the project.

- If the project is solely to address infrastructure state-of-good-repair, it would be considered a 3R project. No revisions to geometry would normally be considered, rather, the design focus would be on addressing the infrastructure condition need. Agencies by policy may choose to programmatically include safety enhancements for which the marginal additional costs are low or negligible (e.g., adding rumble strips as part of pavement resurfacing). They also may undertake programmatic measures such as pavement marking upgrades, sign replacements, and utility pole relocations.
- If the project need is fundamentally to improve safety or traffic operations, the geometric design process is focused on the body of substantive safety knowledge (as published in the AASHTO HSM or other technical references designated by the owning agency) or traffic operational knowledge (as published in the HCM or other technical references designated by the owning agency). A project may involve both operational and

substantive safety needs, in which case both sets of references would apply. Systemic safety improvements should be included to any projects that have the identified risk factors.

- For reconstructed roads, the recommended process further differentiates between roads to remain as the same fundamental type, and roads to be reconstructed within a right-of-way corridor, but to a fundamentally different type. Changes in type would include addition of continuous basic lanes (e.g., expanding a two-lane highway to a four-lane highway), converting from a semi- or uncontrolled access facility, and constructing an interchange or roundabout to replace an intersection.

### 5.6.2.1 Reconstructed Roads to Remain the Same Type

The geometric design process for reconstructed roads to remain the same type focuses on development of cost-effective solutions, with the actual safety and operational performance of the existing road serving as the baseline for alternative development. The actual crash history is directly relevant and applicable to the expected safety performance, from which crash cost benefits are computed. Actual speed and travel time data also are used to compute user operating and travel time costs. Proposed improvements to the road to address the identified needs would come from reference documents of proven effective treatments such as the HCM and HSM. The envisioned process for such projects would be a cost-effective analysis approach (versus an application of dimensional criteria). The project context plays a dominant role in determining cost-effectiveness, hence tailored solutions would be produced. For example, projects involving a horizontal curve with a high potential for safety improvement (PSI) may have different solutions based on the specifics of the site. In some cases, curve flattening may be the best solution; in others widening and paving the shoulder, treating the roadside, or implementing speed reduction measures may be more cost effective.

- Geometric revisions would be made only for those roadway elements directly related to the identified problem
- A design process would apply science-based knowledge on operation and safety performance, with the designer developing alternatives using the tools and methods from the HCM, HSM, or other similar references; with benefits calculated for the service life of the project
- The location-specific costs of construction and maintenance would be calculated over the service life, and an optimized cost-effective solution obtained from the benefits and costs
- The roadway geometry at the project limits would provide a strong basis or reference for potential revisions.
- The process would naturally favor solutions that do not require additional right-of-way (or require readily available right-of-way in return for a significant improvement in performance). The process also would not require the comparison of the solution with published criteria and a design exception.

### 5.6.2.2 Benefit/Cost Process for Reconstructed Roads

The following summarizes the geometric design process based on comparison of the benefits and costs of alternative design solutions. The process relies on objective measures of transportation performance:

- Crash costs would be derived from AASHTO HSM or other approved references for effects of roadway geometry and treatments on crash frequency and severity
- Crash costs would be based on valuations for fatalities, injuries, and property damage only crashes as published in research (e.g., FHWA) and adopted by policy of the owning agency
- User operating costs would be based on research and tools developed from the AASHTO Manual of User Benefit Analysis for Highways 3<sup>rd</sup> edition (28) or other similar work, which provides operating cost curves for different vehicle types as a function of operating parameters such as speed (Figure 35).
- User travel time costs would be also based on research on the same AASHTO publication or other similar work, which provides travel time costs as a function of trip type and time saved. (For both operating costs and travel time, incorporation of costs for the range of vehicle types is possible.)

- Initial construction costs would be used per standard agency approaches for cost estimating.
- Annual M&O costs would be obtained from agency asset management systems and databases; and research on the costs of maintenance as a function of context and road geometry.

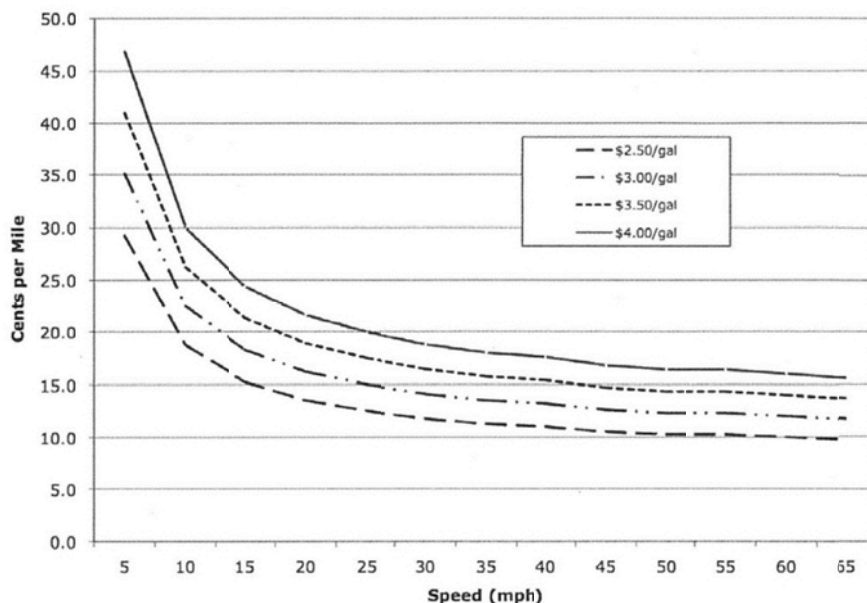

Figure 34. Fuel Costs (Cents per Mile) by Speed – Automobiles ref figure 5-1 User Benefit Analysis for Highways AASHTO 2003

The above valuations and methods would be set by policy and regularly updated for inflation and as additional research is available. Agency staff would be provided software to enable efficient and consistent application of the analysis approaches briefly summarized as follows:

#### Step 1) Develop annual costs for base alternative\*

- Base alternative will typically be the existing condition or no-build
- Determine service life of project and discount rates<sup>#</sup>
- Establish service life traffic projections

Calculate Annualized User Costs<sup>^</sup> =  $\sum$  (crash costs + vehicle operating costs + user travel time costs) for service life

Calculate Agency Roadway Costs\* =  $\sum$  (initial construction + intermediate construction + annual M&O) throughout service life

Intermediate construction would entail infrequent, major construction such as bridge deck replacement, and resurfacing.

<sup>#</sup>Annual costs require the setting of discount or interest rates for analysis purposes. These would be set by agency policy, and may vary to reflect the level of risk or uncertainty associated with a project type or types. The lower the discount rate, the more future projected costs and benefits will represent meaningful values in the analysis.

<sup>^</sup>Agency crash costs would be based on application of agency processes and models, and valuations for injuries and fatalities per agency policies. Vehicle operating and user travel time costs would reflect traffic type distribution (e.g., freight and transit) and agency policies for valuation of travel time. And established operating cost relationships per the literature.

\*Agency roadway costs should assume a level of construction during the service life to maintain a minimum state of good repair by policy and/or regulation. This may include periodic resurfacing and bridge repairs. Agency costs for M&O would be developed from asset management programs to a level of detail supported by the agency's databases and management resources.

## Step 2) Develop Alternative Solutions -- Consult appropriate references for geometric design and traffic operational solutions that address the problem(s); select and design the context

Designers would be provided initial guidance on the most effective solutions given the traffic volume levels, crash types, and expected costs. Effective solutions will be expected to generate lower annual crash costs, lower vehicle costs, lower user travel time costs, or a combination of these. They would select a reasonable number of solutions, perform sufficient engineering design to establish the three-dimensional footprint, estimate right-of-way, and estimate construction costs. Based on the design solutions they would perform the following:

Calculate Annualized User Costs for Alternative =  $\sum$  (crash costs + vehicle operating costs + user travel time costs) for service life

Calculate Annualized Agency Roadway Costs\* =  $\sum$  (initial construction + Intermediate construction + annual M&O)

Effective solutions may involve initial construction including right-of-way beyond the base condition. Intermediate construction costs would reflect the timing and extent of the improvement. Annual M&O costs for the alternative may be greater or less than the base condition depending on the specific solutions. In general, the annualized agency costs for an improvement will be greater than the base condition annualized costs.

## Step 3) Determine Cost Effectiveness of the Alternative

Annualized benefit to cost (B/C) ratio =  $\sum$  User Benefits /  $\sum$  Increased Agency Costs

Where  $\sum$  User Benefits =  $\sum$  (crash costs for base alternative – crash costs for alternative) + (vehicle operating costs for base alternative – vehicle operating costs for alternative) + (travel time costs for base alternative – travel time costs for alternative)

$\sum$  Increased Annualized Agency Costs =  $\sum$  (total agency roadway costs for base alternative – total agency roadway costs for alternative)

Multiple design alternatives would be tested against each other, with the optimal alternative among build solutions producing a marginal B/C ratio > 1.0.

Agencies would need to establish policies for minimally acceptable B/C ratios based on their total available resources and priorities. The quantitative benefits will generally accrue to agency customers – the road users. In many cases, these benefits will require an increase in agency costs through initial construction, long-term maintenance, or both. The optimal solution among multiple alternatives may require the greatest long-term investment by the agency. For these reasons, a minimum project threshold for B/C ratio > 1.0 may be programmatically untenable for the agency. The setting of minimal threshold B/C ratios assures that every project will be affordable over time (at least to the extent the agency is able to forecast its future costs and revenue). The threshold policies could change over time as an agency's available resources change. Indeed, the level of an affordable B/C ratio would be a key management metric that would be useful to those responsible for providing funding and resources to the agency.

This process does not rely on externally published dimensional criteria. It therefore would not necessitate the characterization or approval of an exception to design policy for any solution. Given this framework, the only exception may be the selection and implementation of an alternative that does not meet minimal agency thresholds for cost-effectiveness. Assuming that agencies adopt policies that value fatalities and injuries in a manner consistent with that given in the HSM, this process will naturally result in designers focusing on alternatives that produce measurable reductions in serious crashes, and that do so with minimal construction. This outcome is the central objective of agency policies such as practical design.

### 5.6.2.3 Design of Reconstructed Roads for Conversion to New Road Types

A separate AASHTO Policy for Reconstruction of existing roads is recommended for roads fully reconstructed within existing right-of-way to a different road type (e.g., two-lane rural to multi-lane, three-lane urban to multi-lane, road for motor vehicles only converted to one for multi-modal use). The AASHTO Green Book for Reconstruction of Roads would include design criteria similar in nature to the New Roads Green Book, but



*it would describe a design process* in which appropriate dimensions are established that reflect the practical limitations of the location and the incremental costs and benefits of dimensions in the specific context.

If the nature of the primary problem being addressed is traffic operational, the design process would be diagnostic, using the knowledge, tools, and methods representing best practices (e.g., the TRB HCM or other manuals or methodologies endorsed by the owning agency). In many cases the traffic operational problem may be traffic demand exceeding the capacity of the road during certain times of the year, in which case the HCM would serve as the basis for providing additional capacity, managing demand, or optimizing the operation of the road. Operational improvements might include construction of medians for left-turn refuge, retiming of traffic signals to facilitate pedestrian trips, and restriping or widening of the cross section to enable bicycle operations. The dimensions associated with achieving improvements may vary based on the context, with, for example, narrower left turn lanes adopted should this be the only way to provide left turn capacity given limited space.

If the problem is a substantive safety problem, the design process would be diagnostic, using the knowledge, tools, and methods representing best practices (i.e., the AASHTO HSM). Geometry unrelated to the specified problem can be presumptively retained. Changes in the operational performance of the roadway associated with the safety improvements would be characterized and included in the final documentation of the selected design solution.

For those projects in which both safety and operational problems need addressing, the design process would direct designers to consult both primary references. Agencies may develop shortcut procedures or establish hierarchies of preferred approaches that combine operational and safety issues. Differences among agencies may be expected based on their unique contexts, budget priorities and policies, but the underlying approaches would be consistent assuming the agencies are referencing the same body of technical knowledge on the geometric effects on safety and operational performance.

Regardless of the problem(s) being addressed, designers would have the flexibility to adjust or redesign alignment or cross section, but their emphasis should be on solving the problem given the unique site constraints, including the availability and costs of right-of-way, and impacts during construction to adjacent landowners. The design process would directly incorporate such costs in the determination of the optimal solution.

The reconstruction design process would automatically promote the concept that an appropriate solution for a given problem in one context may be unworkable in another, thus requiring a different solution (or perhaps different dimensions). With an expanded knowledge base and training, designers would learn to quickly focus on those solutions most likely to provide the optimal value. Moreover, their recommended design solution would be optimal for the context and thus not in need of being labeled a design exception. Finally, road geometry incidental or unrelated to the identified problem could presumptively remain unless there is evidence from performance models of a meaningful loss of performance value with a given alternative.

#### 5.6.2.4 Design of 3R Roads

If the problem being addressed is only infrastructure condition, the road would be designated as 3R. The basic geometry would remain unchanged, unless the designer can demonstrate that the revisions will be cost effective in terms of the return on investment using the established benefit/cost analysis procedures. The 3R process can allow for designers to include low-cost safety improvements when the marginal cost of such improvements is clearly small or negligible. For example, in resurfacing a shoulder, the inclusion of rumble strips can produce meaningful benefits with minimal additional costs.

### 5.6.3 Develop Project Technical Approach

The project technical approach is the detailed work plan for the project team. This would include what data are needed and to what level of detail or precision (survey, traffic, crash, utility information, environmental data, and construction cost). The project technical approach also would include the outlining of interim and decision deliverables leading up to the selection of the preferred design plan.

## 5.7 Step 7 – Designing the Geometric Alternatives

Only after the previous four steps have been carefully and fully completed should the geometric design process proceed. First and foremost, the process must be understood and executed as an **alternatives development process**. Regardless of the project size, scope, and problems being addressed, there is always more than one reasonable geometric solution. The process itself involves multiple steps and subprocesses outlined below.

### 5.7.1 Assemble an Inclusive and Interdisciplinary Team

Geometric design is the technical means by which the intended performance of the roadway is accomplished, within the bounds of affordability and respect for the context. Geometric designers should have strong working knowledge and/or access to other individuals who can work with them in the disciplines of traffic operations, hydrology and drainage, bridge and structures, geotechnical engineering, and construction. In particular, traffic engineering and operations expertise is needed. In many cases the optimal solution will include stakeholder engagement activities, and combined geometric design and operational components.

### 5.7.2 Focus on and Address the Need or Solve the Problem(s) within the Context Conditions and Constraints

The geometric design process should be focused on solving the objective, identified problem(s) confirmed in Step 3. Solutions that are cost effective reflect the unique context conditions and constraints established in Step 4.

For projects involving existing roads the starting point is the existing geometry and footprint of the road. For projects on new alignment, the road designer has a clean slate, and thus requires some basic guidance to initiate alternatives development. For these project types, designers require basic geometric design criteria as a core starting point. Such criteria by necessity must be expressed as physical dimensions. The use of design criteria expressed as dimensions should be understood as a means to an end, the end being performance (operation and safety). The costs associated with constructing given dimensions, and the resultant performance of the road built to such dimensions, can vary based on the unique context conditions. For these reasons, the geometric design process for roads on new alignment may produce unique or tailored designs more often than not.

#### 5.7.2.1 Unique Designs and Driver Expectations

The concept of unique versus standard or typical designs requires explanation, as some designers express concern over driver expectations when a unique design is offered. The concept of uniqueness addresses the context-specific features of the roadway environment that influence how well it respects the surrounding land use and features, and what the costs to build and maintain it may be.

Table 18 shows driver expectations from human factors research (29). They can be summarized as follows:

- Design of decision points or route choices (turns at intersections, exiting, through movements)
- Placement, type, and messages of signs and traffic control devices
- Colors and patterns of traffic control devices and features
- Appearance of the alignment (in particular, horizontal alignment) and consistency with preceding alignment
- Abruptness and severity of changes in width
- Notice to drivers of significant changes in the road character

Done properly, there is no inherent risk to driver expectations associated with meaningful revisions in the cross section (lane widths, medians and median width, roadside character) or alignment as long as sufficient notice through both sight lines and traffic control devices is provided. Should a unique context feature or features exist, the design process for new roads should be sufficiently flexible to not only allow but encourage the designer to test alternative geometric solutions, and select the optimal design based on the performance and cost analysis of

the range of possible solutions. Done properly, such a process should result in the preferred solution and not one that is labeled an exception.

Table 18. Design and Traffic Control Measures to Address Driver Expectations

Arrangement of Roadway Features and Navigation or Route Choices	Arrangement of Roadway Elements Influencing Speed, Acceleration and Deceleration Behavior	Location, Design and Messages of Traffic Control Devices to Communicate and Reinforce Appropriate Driver Behavior
Upcoming freeway exits will be on the right-hand side of the road	When a minor and a major road cross, the stop control will be on the road that appears to be the minor road	Mix of two-way and all-way stop control along a route
Consistent interchange exit type (before or after cross road structure)	Speed limit changing for a short segment or dropping by more than 10 mph	Consistent roundabout signing and lane use
At splits where the off-route movement is to the left or where there is an optional lane split	Tight curve after long tangent	Traffic signal placement and number of heads provided – mast arm mounted signal heads
When approaching an intersection, drivers must be in the left lane to make a left turn at the cross street, vice versa for right	Narrowing of lanes, shoulders, or other cross section elements	Consistent sign size and placement
Intersection, access point, horizontal curve after crest vertical curve	Freeway acceleration lane reduction made so far downstream that motorists become accustomed to a number of lanes and are surprised by the reduction.	Uses of colors on signs, pavement markings and traffic signals to denote core messages
Trap lane, Through lane becoming turn only or special purpose lane	Uniform application of traffic control devices with respect to the amount of change in the roadway alignment conveys a consistent message	Consistency of navigational signing (type and frequency of signing)
A continuous through lane (on a freeway or arterial) will not end at an interchange or intersection junction		
Prohibited turn movements		

Derived from information in the Transportation Research Board National Cooperative Highway Research Program Report 600, Human Factors Guidelines for Road Systems.

### 5.7.2.2 Exercise Design Flexibility – Choices and Trade-offs

AASHTO has promoted the notion of design flexibility for some years, including most notably in their policy document *AASHTO A Guide to Achieving Flexibility in Design*. In practical terms, design flexibility means that designers have choices and not mandates. Choices relate to the level of transportation service provided for all modes, the inclusion or exclusion of specific features (lanes by type and usage, medians by type, on-street parking), treatments (intersections versus roundabouts, types of intersections, types of interchanges), and dimensions for each element.

The revised geometric design process for new and reconstructed roads should promote the hierarchy of choices with respect to their relative importance in influencing operational and safety performance. Figure 36 illustrates this hierarchy. The most important decisions involve roadway type (both segments and intersections, including the extent of access control and number of lanes). Of secondary importance is the presence and arrangement of roadway features such as medians, turn lanes, and intersections. Of lesser importance are the dimensions associated with the roadway elements (i.e., within the normal or accepted range of those dimensions). For example, the speed, capacity, and crash-risk profile of a road in a rural context is much more influenced by the basic type (two-lane, multilane with partial access control, multilane with full access control) than the dimensions of lane width, shoulder width, curve radius, or stopping sight distance. Designers should understand that their

fundamental mission is to provide the optimal design for the given roadway type. Flexibility and creativity contribute to the assembly of the three dimensions of the road to fit the context, maximize transportation value, and minimize life-cycle cost.

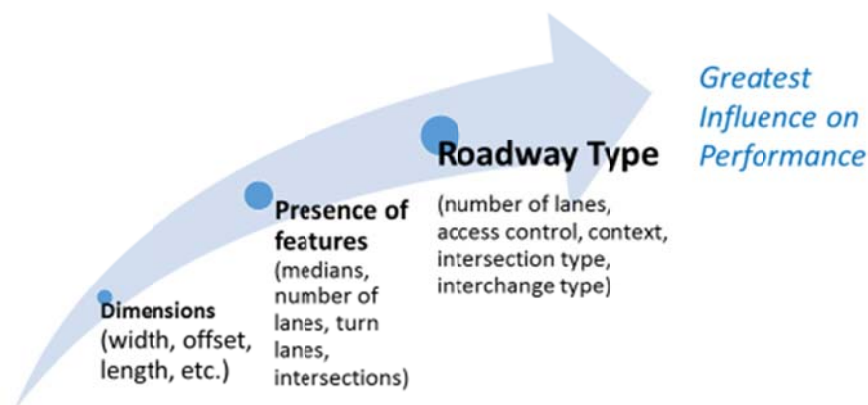

Figure 35. Hierarchy of Roadway Design Decisions and Their Relative Importance

This approach conflicts with the traditional design thought process as employed by most highway engineers and promoted by most agencies. The traditional approach focuses on design dimensions as the most important feature; moreover, it reflects a mental model of transportation performance and value illustrated in Figure 15. Minimum design criteria, typically expressed in dimensional values related to a design speed or other control, are automatically selected as the preferred solution. This approach applies to cross sectional elements and stopping sight distance (the latter value is not directly designed but rather translated into dimensions for vertical curvature and horizontal offsets). Some designers do not explore or test greater widths or longer vertical curves than the minimum values, because 1) they believe they will automatically cost more to construct, 2) influential stakeholders push for the impacts to be minimized, and 3) they are not believed to provide additional transportation value. Many designers do employ a full range of values for both horizontal and vertical alignment, but even this design thought process reflects a basic construction cost focus, with curves and grades selected to fit the terrain and tie into other roads, avoid physical conflicts or minimize retaining walls and other costly structural elements.

Among the most significant changes in the geometric design process should be the adoption of the mental approach to design decision-making illustrated by the orange line in Figure 15 shown previously. A highway designer needs a starting point or base condition, but the process of dimensional choices and tradeoffs should drive the designer in all aspects of the design (cross section, horizontal alignment, and vertical alignment).

### 5.7.2.3 Design to an Appropriate Level of Detail throughout the Design Process

The roadway design process, of which geometric design is a centerpiece, is actually a series of subprocesses which translate thoughts and ideas into design data and drawings to a level of detail sufficient for construction. Individual phases of the design process serve varying needs and involve different types and criticality of decisions.

The geometric process of alternatives is a continuum as demonstrated in Figure 37. Initial designs may be developed in plan-view only, referenced to aerial photography with simple supporting sketches. Skilled designers can effectively portray a plan that accommodates the third dimension (elevations) without actually designing such dimension, even for relatively complex projects such as interchanges. Taking full advantage of computer-aided engineering tools, this process facilitates development of multiple solutions.

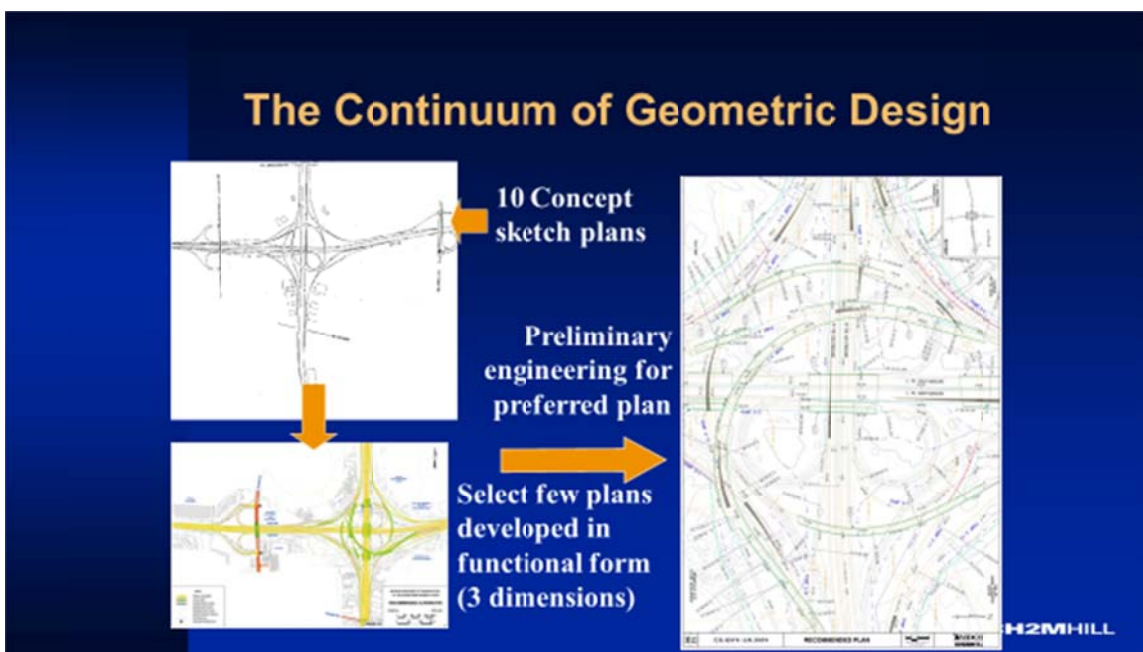

Figure 36. The Continuum of Geometric Design

Early in the alternatives design process, the design engineer works in appropriate scales for the context, and applies as much detail as is necessary to confirm key impacts such as right-of-way conflicts to enable screening down to the most promising designs. Many engineering details are purposely ignored or deferred for investigation in later phases. Design drawings are generated both for internal working purposes and external stakeholder interaction.

The concept of using proper scales in design is important regardless of the ability for the designer to print or plot their plans at any scale. Working at too large a scale (1 inch equals 20 feet) in early concept planning is highly inefficient as it is difficult for a designer to absorb the information, and easy for the designer to have their attention diverted to details that do not matter early in the process. Also, stakeholders (many of whom will be non-technical in their background) will require varying levels of detail and scale to perform their reviews, and the appearance of deliverables for their use should be tailored to maximize their understanding and facilitate their input. The concept of varying the scales and appearance of deliverables is illustrated in Figure 37.

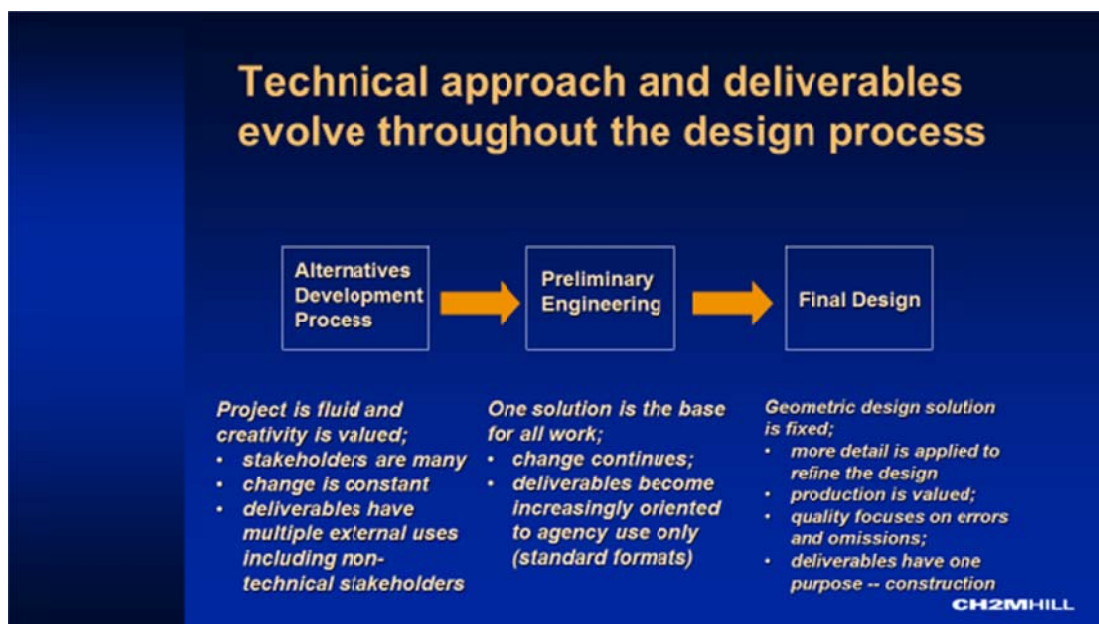

Figure 37. Tailoring of the Design Approach and Deliverables to the Major Project Phases

Multiple alternatives can be evaluated for their effects and costs, enabling screening, and selection of the most promising alternatives. As geometric design progresses and the number of alternatives is narrowed, the level of effort and detail is increased. The third dimension may be developed over digital terrain mapping (vertical alignment) with supporting engineering showing basic structure dimensions. Additional insights such as visualizations or “virtual drive throughs”, estimates of earthwork quantities, and modeling of environmental impacts such as noise can be completed.

When the process has reached the point at which the number of viable solutions is limited, further study detail (geometric design and performance) can be efficiently performed for the remaining viable solutions. This concept is described in Figure 38.

For the most promising alternatives, the level of detail should be sufficient to fully characterize the necessary right-of-way and basic construction elements and quantities. As a minimum, the geometric design involves the horizontal alignment of control line geometry and edges of pavement, the typical section, and the vertical alignment of the control line and edges of pavement. The geometry should be referenced to the terrain developed from mapping to a sufficient level of quality such that right-of-way lines can be set and evaluated.

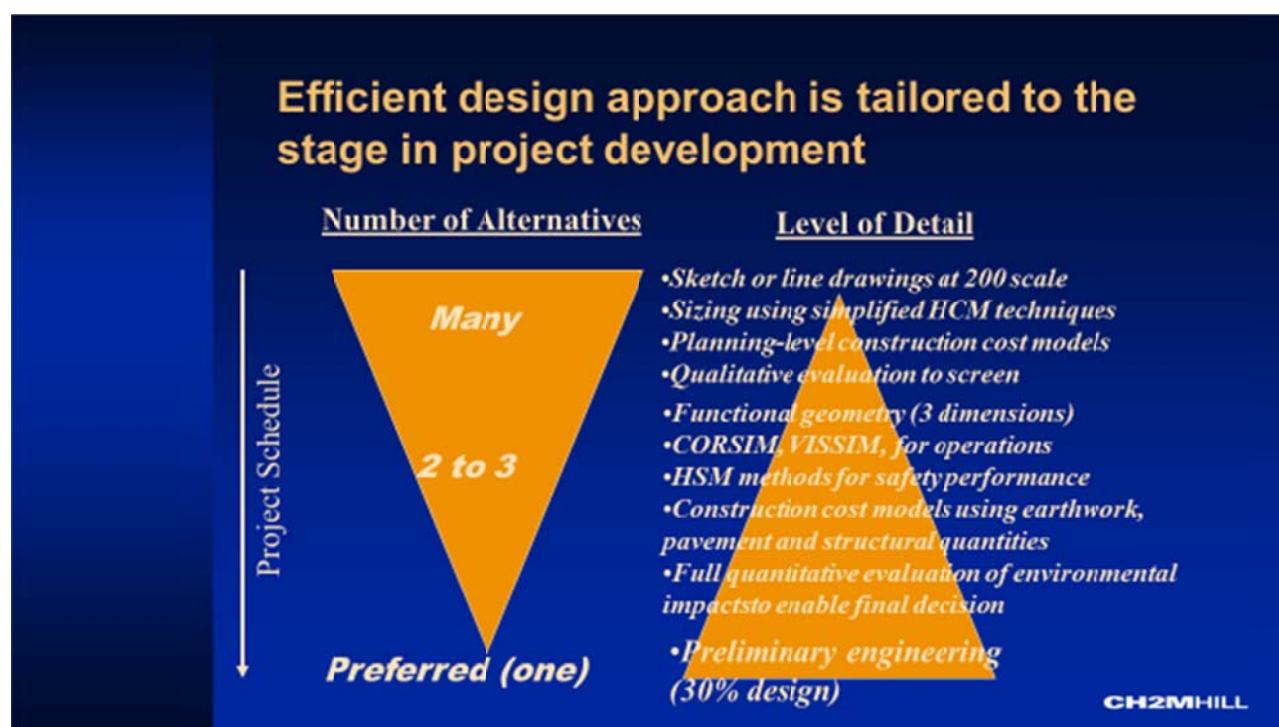

Figure 38. Tailoring the Technical Approach of Performance Evaluation to the Phase of Alternatives Development

#### 5.7.2.4 Maintenance and Operations

The recommended process for all project types should incorporate explicitly life cycle costs of M&O activities. Section 8.3 contains a detailed discussion of the relationship of maintenance to roadway design. Note that maintenance needs and issues are strongly context sensitive. O&M needs and costs will vary by road type, terrain, climate and traffic levels. The knowledge base on the incremental or unique O&M costs associated with highway design features or incremental dimensions is limited. *The Handbook of Road Safety Measures* contains some information on this topic, but there is clearly much more research needed that is beyond the scope of this research project.

#### 5.7.2.5 Performance Iteration in Geometric Design

The conventional or traditional geometric design process has been an iterative process in which the highway designer’s efforts are focused on minimizing the construction quantities and right-of-way for a given geometric solution.

Advances in the knowledge base of both traffic operations and safety are such that the mental model of Figure 15 is demonstrably not correct. The measurable performance of a design can and does vary as dimensions and elements are tested and iterated. Alternatives fully meeting applicable design criteria may differ significantly in their expected safety and operational performance.

The revised geometric design process incorporates science-based analytical models and methods that provide predicted quantitative outcomes based on the geometry. Such outcomes would ideally include:

- Expected cost to construct
- Expected crash frequency over project life
- Expected crash severity over project life
- Expected travel time(s) by time of day over project life
- Expected cost to operate vehicles over the project life
- Expected annual maintenance over project life

As shown in Figures 38 and 39, performance-based tools tailored to the phase in the process can provide sufficient information to each phase. Lookup tables, default values, and short-cut analysis procedures may be used to screen to a limited few designs, and full modeling (microsimulation for operations; HSM predictive methods via FHWA's IHSDM for safety) for those few surviving alternatives is an efficient approach. For simple projects, full simulation may be unnecessary.

Transportation performance outcomes for a given iteration could be translated to annual user costs (crash costs, travel time, operating cost); and to agency life-cycle costs (annualized construction and annual maintenance costs) for the entire service life of the project. A cost-effectiveness function or index value could be produced for the alternative. Subsequent iterations in any aspect of the design would produce differing performance and cost values, and differing cost-effective functions or index values.

## 5.8 Step 8 – Design Decision-making and Documentation

The ultimate decision regarding the preferred geometric design solution is made by the agency responsible for funding, construction, and maintenance. Many projects will be performed within an environmental regulatory framework which requires complete analysis and documentation of expected impacts and mitigation measures. The recommended geometric design process adds the expected traffic operational and safety performance benefits of the optimized plan. Assuming steps 1 to 7 are conducted as discussed, the recommended plan should be evident from its optimized features.

***The most important documentation should be the statement of the problem being addressed and summary of how the recommended design will address the solution.*** In the context of the United States environmental process, this is referred to as meeting the purpose and need. This documentation and discussion should be quantitative in nature. The documentation should also include the geometric design framework, design controls, constraints, and decision processes, with particular attention paid to describing the values of the community and decision makers and how they influenced the selection of the preferred alternative. This documentation should be referenced in the Record of Decision (ROD) which concludes an Environmental Impact Statement, and the Finding of No Significant Impact (FONSI) which concludes the Environmental Assessment.

### 5.8.1 Independent Quality and Risk Management Processes

A number of important independent design processes have evolved over the past 30 years and are now considered fundamental to roadway project development. These include value engineering (VE), road safety audits (RSA), cost-estimating validation processes (CEVP), and alternative technical concepts (ATCs). These processes evolved as a result of a perceived lack of:

- Optimization in value received as part of the traditional design project development process
- Sensitivity to safety performance by road designers

- Foreseen circumstances or conditions that greatly increased the cost of projects (usually large and/or complex projects)

Many agencies purposely separate Steps 8 and 9 either internally or in their use of design consultants. In the intervening periods of re-assigning the project to others, these processes are often undertaken.

The following is a discussion of how these independent processes may fit or best be performed in the revised geometric design process.

#### 5.8.1.1 Value Engineering

VE is a specific process required for projects using federal funds above a minimum constructed value threshold. VE involves a carefully assembled multidisciplinary team that meets over a one-week period, facilitated and managed by a trained, professional VE specialist. The concept behind VE is to challenge and test the assumptions and controls, and the specific solutions to a project in an independent manner. The VE participants seek to increase value, reduce cost (without degrading value) or both. Their work product is a report to the owner that outlines specific refinements or changes to the plan, with an assessment of the potential value increase or cost saving. Project owners then decide to accept or reject each suggestion.

VE is most effective when incorporated earlier in final project design development. VE workshops that are held at the outset of the preliminary and final engineering stages offer the time to implement change and avoid wasting or having to redo final design efforts.

The recommended design process that is more performance based and that focuses on alternatives and the tradeoffs blends very well in that performance or value (what is the problem in objective terms, what solution was reached, how well will the solution address the problem in objective terms) is highlighted. This serves as a firm benchmark on which the VE process can build. Even a well-completed project can benefit from trained, independent observers within a well-run VE workshop setting.

#### 5.8.1.2 Road Safety Audits

Road safety audits (RSAs) have become a standard tool for many agencies. An RSA is conducted by a multidisciplinary team of traffic engineers, safety specialists, law enforcement, human factors, and maintenance and construction experts. Through a combination of data analysis and review, and collaborative field exercises to view the project site, the RSA team seeks to make low-cost safety improvement recommendations that are consistent with the scope and nature of the project. These may often represent insights that go beyond published standards, but relate to unique risks or conditions that may pose particular problems to drivers.

Some agencies apply RSAs to certain project types (typically HSIP or safety-focused 3R or reconstruction projects); others are seeking to incorporate RSAs on all project types involving existing roads. The revised geometric design process should acknowledge this independent subprocess, and encourage its application at appropriate times as follows:

- For 3R projects (in which state-of-good-repair is the fundamental problem) the RSA may best be conducted at the beginning of the project—after Step 4 and during Step 5. Indeed, the RSA may be a primary source of ideas for including very low cost safety improvements as part of the project.
- For reconstruction projects that may include safety performance, operational performance, or both, the RSA may best be performed following Step 8, with the focus being a review of the preferred plan. This will necessarily involve a virtual review using design visualization of the three-dimensional geometry.
- For roads on new alignment, the value of an RSA is questionable. If performed, it should occur during Step 9, with the focus of the review being a virtual drive-through of the roadway. The RSA may include review of signing and traffic control placement (noting visual conflicts with overhead structures, tree limbs, and plantings) and a second look at roadside barriers and attenuation to assure they are both necessary and properly placed.



### 5.8.1.3 Cost Estimate Validation Process

The cost estimate validation process or CEVP was developed by the Washington State DOT (31). It addressed a problem associated with major highway projects of great complexity having long development times. The many risks associated with moving through project development to construction often resulted in unforeseen increases in construction cost that emerged between the time when the final decision was made and actual construction plans completed for bidding. CEVP uses a Monte Carlo simulation process in which many aspects of the project are assessed as to their risks of change over time and resultant potential effects on constructability and cost. CEVP allows characterization of a probability that a project will not cost more than a given amount. It also provides an analytical method for testing potential changes, and for proactively managing the project as it moves through final engineering to address the risks of change.

The revised geometric design process does not mitigate or reduce the need for or value of CEVP. Indeed, an optimization process is reliant on the quality of estimates of cost, and to the extent that these are uncertain in the middle of design development, the risk is that the solution will end up being suboptimal. The CEVP should be performed early in Step 9 and updated depending on the length of time necessary to complete final engineering.

### 5.8.1.4 Alternative Technical Concepts

The Alternative Technical Concepts (ATC) process is a fundamental process within the Alternative Project Delivery Design Build (DB) process.

A typical DB project involves three to five competitive teams who are typically provided proposed contract terms and an owner's preferred design, which typically reflects a level of engineering consistent with that described in Step 8. It includes the basic roadway design in three dimensions, right-of-way, environmental mitigation and related features, and basic structural solutions. The terms for selecting the winning firm are spelled out in the Request for Proposals. These may be lowest constructed cost, lowest cost with credit for reduced time of construction, or (in states where legislation allows this) a selection in which factors relating to schedule, quality, additional features, and cost may all be used to score a proposal. Selection of the winning team is through a carefully defined process that may include a scoring process in which schedule, budget, and quality (clearly defined) are evaluated. The process where allowed by state procurement laws is often referred to as best value.

Contractor teams compete in a process to complete the design detail using their own ideas; and that does not necessarily require all the engineering details that agencies typically seek for traditional plans. An important feature of DB is the inclusion of ATC. Owing agencies furnish the 30 percent plans and ground rules or boundaries for ATCs, but then invite the competitive teams to submit their own unique ideas for changing the design to accomplish a stated goal or objective of the owner in a manner demonstrably better than that provided by the owner's plan.

ATCs can include substantive changes to the original concept. For example, they may include reconfiguration of an interchange, re-alignment (horizontal, vertical, or both) to reduce construction costs, re-allocation of widths in the cross section, or other major geometric changes. ATCs also may involve alternative pavement designs, alternative structure designs, and different traffic control plans than originally envisioned during construction. The ATC process is where the potential value over traditional design/bid/build exists.

The FHWA and AASHTO acknowledge that the current project development process often produces less than optimal design solutions.

ATCs represent the opportunity for a fresh set of eyes to review the project and propose innovative ideas to meet owner objectives. As such they may continue to be part of project development. The revised geometric design process outlined above, if carried out as intended, would automatically address many of the perceived shortcomings of current project delivery that have led to the attraction of ATCs. Many ATCs emanate from projects that did not undergo rigorous alternative development. Many ATCs also involve design exception ideas in which the ATC proposer demonstrates performance values at lower costs by changing a design dimension or design control. A well-performed design study would tend to negate many of these sources of ATCs.

Some ATCs involve materials and specifications, construction means and methods, or other elements that may have limited or no influence on the geometric design of the road. For major projects, ATCs often focus on differing ways of managing traffic or detours during construction to minimize costly phasing and shorten construction time. These would be unaffected by a new design process.

For agencies employing ATCs, it is critical that the stated design controls and values developed during project development are retained in the value scoring process, and in the guidelines around what is considered acceptable. Project procurement (DB or conventional) is often managed by different staff and offices within DOTs. As projects are handed off the institutional memories and values associated with decisions risks being lost. This is one major reason for the emphasis on good and complete design documentation.

## 5.9 Step 9 – Transitioning to Preliminary and Final Engineering

The final step in the geometric design process follows the selection of the preferred plan. This includes the full design and detailing of all elements of the roadway, including below-grade features such as closed drainage systems and utility relocations. The scale of the drawings produced is typically increased and multiple notes and other specifications added to the drawings to produce bid-ready and construction-ready documents.

Note that this last step of the design process – the detailing of the basic selected functional geometric plan – typically requires 70 percent or more of the engineering effort and design schedule. It is not necessary and indeed wasteful to perform detailed design work and calculations on more than one alternative, when the element in question either has no bearing on selection of the preferred plan, or the geometric details of the preferred plan are needed to enable the calculations.

The preliminary and final engineering phases of work are performed on the selected and approved geometric design. The focus of these phases is to add design detail regarding road elements separate from the basic roadway. This effort includes surveys and plans for right-of-way acquisitions and easement. Engineering design also include subsurface elements (utility locations or relocations and stormwater management), detailed drainage and erosion control, lighting, signing and ITS elements, traffic control devices, roadside barriers\*, sound walls, striping, and landscaping. The functional design (type and location) of guardrail and other roadside barriers should be advanced into Step 7. The presence of barriers has a known and significant influence on safety performance. Exercising the HSM or other safety models thus requires at least preliminary design of barriers. Barriers also are significant maintenance elements. The exercise of cost models for roadway maintenance will undoubtedly require location-specific information on guardrail and other barriers during the alternatives evaluation and selection steps.

Step 9 engineering design also will include preparation of detailed plans for maintenance of traffic during construction. Bridge design work in earlier steps is typically limited to sketch plans or type, size, and location plans; with detailed bridge calculations and final design occurring in final engineering. Specifications for construction also are prepared in the final engineering phase of work.

It is commonplace, particularly in urban contexts, for there to be revisions to road geometry as the level of detail increases and conflicts or unforeseen conditions arise. In most cases these changes will be minor in terms of the effect on the operational and safety performance intended by the efforts through Step 6. However, circumstances sometimes arise that force major changes in the plan concept. Such circumstances may include preliminary cost estimates that greatly exceed the budget requiring redesign, subsurface conditions that require different structural solutions, and difficulties in acquiring right-of-way that result in redesign to avoid the acquisition.

The majority of the effort involved in developing plans for construction is typically included in these phases of work; generally considered to be 70 percent of the overall engineering design effort. What is unique about this 70 percent effort is that it is solely focused on providing the detail sufficient for bidding and construction. **Once the basic road design is set per Step 6, the focus changes away from transportation performance to the implementation tasks of procurement and construction.**

For major projects an important subprocess would be the rerunning and confirmation of the analyses that documented the operational and safety performance of the final plan. This should occur at the 90 percent to 95 percent stage of engineering (typically associated with quantity estimates, specifications development, and final quality assurance reviews).

### 5.9.1 Technology Applications -- Building Information Modeling

Geometric design and the assembly of final engineering plans has traditionally been a paper focused, two-dimensional process in which calculations and data describing the road are translated to drawings that are dimensional, with written notes and specifications supporting the plan sheets. In recent years, advances in infrastructure technology development have produced what is referred to as Building Information Modeling (BIM).

The US National BIM Standard Project Committee has the following definition:

*Building Information Modeling (BIM) is a digital representation of physical and functional characteristics of a facility. A BIM is a shared knowledge resource for information about a facility forming a reliable basis for decisions during its life-cycle; defined as existing from earliest conception to demolition. (NCHRP Report 362).*

BIM treats roadway design data in five dimensions -- spatial (width, height, and depth), time, and cost. BIM is the representation of a design as combinations of objects, with each object defined by data describing its geometry, relationship to other objects, and basic attributes. BIM design tools enable designers to extract different views from a building model (e.g., a roadway design) for production of design drawings and other uses. BIM software also defines objects as parameters in relation to other objects. If a related object is revised, dependent objects will automatically be revised. Each building model element can carry attributes for selecting and ordering the objects automatically, providing construction quantities for cost estimates, and material tracking and ordering.

BIM is now routinely applied to major roadway design projects. When used to its fullest advantages, BIM allows a multidisciplinary team of roadway designers to:

- Design virtually within a 3D world with all disciplines working simultaneously together
- Develop design iterations or scenarios that can be quickly and easily accomplished
- Generate prompt or automated quantity takeoffs from the BIM components
- Automatically detect conflicts or interferences among objects (e.g., utility and pile or foundation), thereby avoiding potential onsite errors or conflicts
- Facilitate design and constructability reviews via virtual model walk-throughs
- Accumulate core business data (e.g., a storm drain pipe may include size and material information) for use in assembling cost and schedule information
- Publish 3D PDF and DWF files for consumption by a wide audience
- Visualize construction during different phases for better visual communication and coordination
- Simulate construction from BIM components

The ability to visualize a design and design impacts in three dimensions is difficult for many designers working with two-dimensional plans. For example, roadways must be able to drain adequately along the entire length. Design criteria for cross slope and minimum grade are intended to assure drainage. However, designers are often faced with situations in which a roadway profile may be in crest or sag curve, and also in horizontal curve or curve transition, in which the pavement is being rotated to develop the necessary superelevation. This unique combination of geometry may result in an unintended consequence of creating road segments that are flat longitudinally and also have no effective cross slope. A 3D BIM evaluation of the pavement contours can readily display this condition and assist the designer in adjusting the horizontal and/or vertical geometry accordingly.

BIM enables the project designers to get real-time feedback of geometric based elements and functionality during the assessment of the existing facility and the design of proposed alternatives. Overlaying the geometric model of existing conditions with design standards and GIS statistical data allows the engineer to visually demonstrate locations of geometric conflicts or locations where criteria may not fit the context. During design, proposed alternatives are quickly evaluated against the design criteria, environmental acceptability, right-of-way availability, and construction impacts to maximize the cost/benefit ratio of making improvements to certain geometric and roadside features.

The geometric model overlaid with GIS data on population density and zoning also can be used in the planning and sequencing of construction. Throughout construction, maintaining safe access for various homes, businesses and other operational considerations is critical. In addition, ensuring construction personnel and equipment can safely navigate the work zone should be considered. The geometric model can be overlaid with seasonal construction schedules to evaluate sight distances and reduce accessibility or obstructions through the various phases of construction. BIM also allows for the direct output and transferal of machine control grading data, accelerating construction operations.

BIM applications to geometric design include the following:

- Verification of pavement elevations to assure drainage (Figure 40)
- Review, confirmation and adjustment to alignment for continuous sight lines to the roadway from driver eye locations (Figure 41)
- Placement of navigational signing and confirmation of adequate sight lines (conflicts with overhead structures and retaining walls on curved alignment)
- Placement of roadside objects to avoid conflicts (signs, light poles, and traffic signals)
- Placement of foundations for mast arms and major sign structures to avoid conflicts with subsurface utilities
- Adjusting alignment and/or cross section to facilitate working space for construction equipment

A logical next step in a fully integrated, data-driven process is the direct linkage of geometric design data into the full suite of operational, safety, and maintenance models. This is the original vision of FHWA's Interactive Highway Safety Design Model, but taken to the ultimate conclusion. The revised geometric design process transitions the historic two-dimensional, paper-based process into a five-dimensional, virtual database development, and evaluation process. Those responsible for roadway design are not merely highway engineers, but managers of large scale, robust databases to be used in all aspects of the highway project development process.

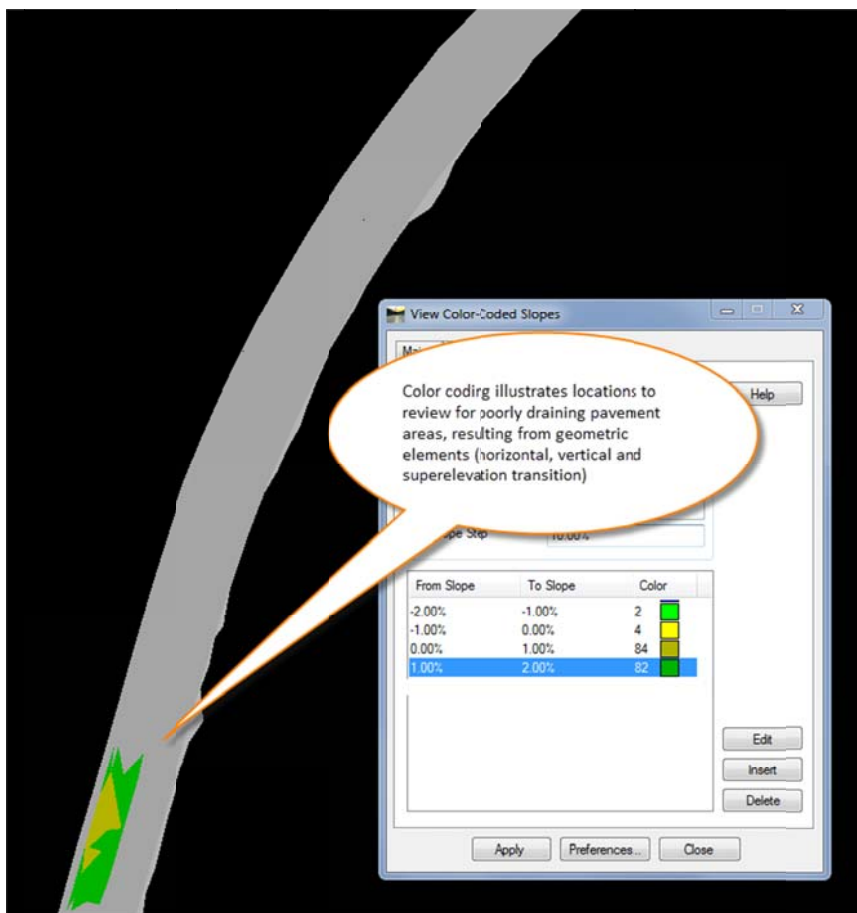

Figure 40. BIM Output to Evaluate Vertical Alignment Design for Drainage

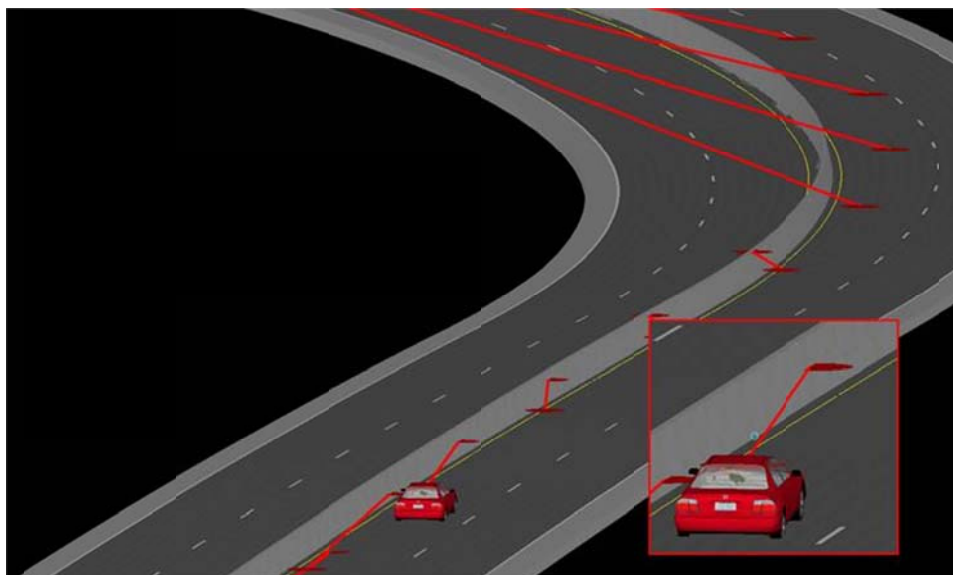

Figure 39. BIM Output to Evaluate Sight Lines along Curved Roadway with Barrier

## 5.10 Step 10 – Agency Operations and Maintenance Database Assembly

The final step in the design development process is to input core project data into O&M databases. Agencies now employ asset management databases and systems to make strategic decisions about future investments, to plan, budget, and execute key maintenance activities, and to continually monitor the status of their infrastructure. The databases and algorithms imbedded in asset management systems rely on carefully defined performance measures.

The recommended geometric design process includes objective analysis of M&O costs. Advances in technology, including real-time infrastructure monitoring conditions, predictive modeling of condition deterioration and failure, and asset management systems are being implemented and gaining acceptance in the industry. An essential aspect of construction or implementation will be the inclusion of ITS technology in projects, and the collection and evaluation of data obtained from the technology. The real-time monitoring and prediction of infrastructure condition to support programming and project decision making is comparable to operational and safety performance monitoring and decision making. The quality and currency of such data will in the future provide agencies the capability of optimal decision making at both the project and program level for both 3R and reconstruction projects.

## 5.11 Step 11 – Continuous Monitoring and Feedback to Agency Processes and Database

The final step in the process is the full utilization of data flowing to the agency from all sources on each roadway within their system. Real-time traffic operational performance data, high quality safety performance data, O&M data, and continuous, self-monitoring of infrastructure condition become central to the design process. Such data are used to continually review and refine the geometric design processes, guidance and decision rules.

The geometric design process envisioned becomes dynamic in response to data and changes in performance that are observed over time. Consider the following trends:

- As multidisciplinary approaches to addressing highway fatalities and serious injuries have been applied in many states over the past 15 years, marked decreases in fatalities have been observed. The effectiveness of any design strategy going forward is less now given the overall frequency of serious crashes than it was previously, which is good, but it heightens the need to constantly revise safety effective design policies and solutions, assuming the positive trends continue.
- The advent of connected vehicles, driverless cars, and other new technology is unknown. It is believed to have substantial safety benefits. As the vehicle fleet changes to include this technology, the benefits will eventually become evident in a further lowering of observed safety risks. To the extent that such technology plays a meaningful role in highway safety, the effectiveness of geometric design solutions to improve safety will lessen. This technology also offers the potential to improve traffic flow (by allowing shorter headways under high volume conditions); which also would lessen the effectiveness of geometric design solutions aimed at improving traffic operations.
- Widespread use of ITS solutions to monitor and manage traffic on all road types is an emerging trend. To the extent that ITS technology replaces the need for roadway infrastructure, this trend may demonstrate the ability to forego either certain design features, or be less constrained in the application of geometric controls (e.g., active traffic management on freeway). Real-time monitoring of traffic and providing speed data in advance of congestion may replace the need for the driver to see a downstream queue, relying instead on the warning of lower speeds.

The roles of technology and other non-geometric measures to address both safety and operational problems and needs is an important emerging trend. Continuous feedback of data, research applications, and increased knowledge will assure that agencies are always applying cost-effective solutions. Such solutions may differ over time from those used in past years, but that should not matter – indeed, it should be welcomed. Over time, agencies may find themselves investing less in physical infrastructure and more in operational solutions, which the geometric design process should facilitate.

## 5.12 References

45. American Association of State Highway and Transportation Officials, *A Policy on Geometric Design of Highways and Streets*, 2011.
46. American Association of State Highway and Transportation Officials, *A Guide for Achieving Flexibility in Highway Design*, 2004.
47. FHWA *Flexibility in Highway Design*, Federal Highway Administration, 1997.
48. American Association of State Highway and Transportation Officials, *Guidelines for Geometric Design of Very Low-Volume Local Roads ( $\leq 400$  ADT)*, 2001.
49. Joint AASHTO / FHWA Context Sensitive Solutions Strategic Planning Process, Summary Report, March 2007
50. Neuman, T., M. Schwartz, L. Clark, and J. Bednar., *A Guide to Best Practices for Achieving Context Sensitive Solution*, NCHRP Report 480, Transportation Research Board, 2002.
51. American Association of State Highway and Transportation Officials, *Highway Safety Manual*, 2010.
52. Transportation Research Board, *Highway Capacity Manual*, Transportation Research Board, 2010.
53. McGee, Sr., H. W., *Practical Highway Design Solutions*, NCHRP Synthesis 443, Transportation Research Board, 2013.
54. MoDOT *Practical Design Implementation Guide: Meeting Our Customer's Needs*, Missouri Department of Transportation (<http://www.modot.org/business/documents/PracticalDesignImplementation.pdf>)
55. Potts, I. B., D. W. Harwood, J. M. Hutton, C. A. Fees, K. M. Bauer, C. S. Kinzel, and R. J. Frazier, "Identification and Evaluation of the Cost-Effectiveness of Highway Design Features to Reduce Nonrecurrent Congestion," SHRP 2 Project L07 final report, MRIGlobal, 2013.
56. American Association of State Highway and Transportation Officials, *Geometric Design Guide for Resurfacing, Restoration, and Rehabilitation of Highways and Streets*, 1977.
57. Transportation Research Board, *Designing Safer Roads: Practices for Resurfacing, Restoration, and Rehabilitation Projects*, Special Report 214, Transportation Research Board, 1987.
58. Crump, E. T., ed., *Relationship Between Safety and Key Highway Features: A Synthesis of Prior Research*, State of the Art Report 6, Transportation Research Board, 1987.
59. Zegeer, C. V., and J. A. Deacon, "Effect of Lane Width, Shoulder Width, and Shoulder Type on Highway Safety," in Crump, E. T., ed., *Relationship Between Safety and Key Highway Features: A Synthesis of Prior Research*, State of the Art Report 6, Transportation Research Board, 1987.
60. Mak, K. K., "Effect of Bridge Width on Highway Safety," in Crump, E. T., ed., *Relationship Between Safety and Key Highway Features: A Synthesis of Prior Research*, State of the Art Report 6, Transportation Research Board, 1987.
61. Glennon, J. C., "Effect of Pavement/Shoulder Drop-Offs on Highway Safety," in Crump, E. T., ed., *Relationship Between Safety and Key Highway Features: A Synthesis of Prior Research*, State of the Art Report 6, Transportation Research Board, 1987.

62. Glennon, J. C., "Effect of Alignment on Highway Safety," in Crump, E. T., ed., *Relationship Between Safety and Key Highway Features: A Synthesis of Prior Research*, State of the Art Report 6, Transportation Research Board, 1987.
63. Glennon, J. C., "Effect of Sight Distance on Highway Safety," in Crump, E. T., ed., *Relationship Between Safety and Key Highway Features: A Synthesis of Prior Research*, State of the Art Report 6, Transportation Research Board, 1987.
64. Cleveland, D., "Effect of Resurfacing on Highway Safety," in Crump, E. T., ed., *Relationship Between Safety and Key Highway Features: A Synthesis of Prior Research*, State of the Art Report 6, Transportation Research Board, 1987.
65. Glauz, W. D., "Future Changes to the Vehicle Fleet: Effect on Highway Safety," in Crump, E. T., ed., *Relationship Between Safety and Key Highway Features: A Synthesis of Prior Research*, State of the Art Report 6, Transportation Research Board, 1987.
66. Harwood, D. W., E. R. Kohlman Rabbani, K. R. Richard, H. W. McGee, and G. L. Gittings, *Systemwide Impact of Safety and Traffic Operations Design Decision for 3R Projects*, NCHRP Report 486, Transportation Research Board, 2003.
67. Neuman, T. R. "Design Guidelines for Very Low-Volume Local Roads (< 400 ADT)," final report of NCHRP Project 20-7(75), CH2M HILL Chicago, Illinois: May 1999.
68. Ezra Hauer, "Safety in Geometric Design Standards", Professor (Emeritus), Department of Civil Engineering, University of Toronto, December 1999.
69. Institute of Transportation Engineers (ITE), *Designing Walkable Urban Thoroughfares: A Context Sensitive Approach –ITE Recommended Practice*



## 6 Updating the Technical Guidance on Geometric Design in the AASHTO Policies

The approach to design criteria and technical content in the Green Book needs to be updated. The following is a review of the key findings:

- Context matters – and it varies; particularly with respect to the transportation service for vulnerable road users
- AASHTO dimensional criteria should be based on proven, known measurable performance effects
- Speed is an essential input to the determination of design values and dimensions
- Some AASHTO criteria are not sensitive to key context attributes that are proven influencers of performance and cost-effectiveness; specifically traffic volume and road type
- Some AASHTO criteria are overly simplistic in their formulation, or are based on rational models lacking a proven basis in science
- AASHTO design criteria produce inconsistent outcomes with respect to performance
- AASHTO criteria should reflect known interactive safety and operational effects of geometry
- Dimensional guidance should be replaced with direct performance guidance (i.e., dimensions derived from performance metrics) where possible within the AASHTO Policy

The recommended geometric design process still requires published dimensional criteria or methods for deriving such criteria for roads on new alignment, and reconstructed roads on existing alignment, which substantially change the road type. This section of the report addresses the core geometric design criteria as currently published in the AASHTO Green Book, which would presumably apply to new road design.

The most significant finding, which is at the core of the concept of cost-effectiveness in design policy, is the lack of sensitivity to traffic volume and road type in the formulation and application of AASHTO design criteria. Table 3, summarized a review of current AASHTO Policy shortcomings in this area. ***Design criteria lacking traffic volume sensitivity and formulated in a manner that treats all contexts the same are strong candidates for significant revision.*** Design criteria that ignore potentially important interactions with other geometric variables are also candidates for study and potential revision. In reference to Table 1, the following recommendations are made.

### 6.1 Overview of contents of 2011 AASHTO Policy on Geometric Design

The matrix (Appendix B) summarizes the results of a complete review of the 2011 AASHTO Policy on Geometric Design. The research team listed each direct reference to quantitative guidance on design of geometric features. The matrix summarizes the location of each reference in the policy, and then classifies the background behind each reference.

Geometric design guidance is broadly classified as being based on either empirical research, or rational engineering models. In the case of the former, the research basis for a design dimension or value can be further classified as relating to any of the following:

- Spatial or operational characteristics of motor vehicles
- Human Factors (drivers, pedestrians or cyclists)
- Substantive or quantitative safety research

- Substantive Traffic flow or operations research
- Roadway infrastructure conditions

The matrix also summarizes the overall quality or robustness of the research basis, as defined by its context sensitivity, and currency of the research.

There are many geometric elements whose derivation relies on rational engineering models. Many of these models were developed and formulated years ago, and remain as the fundamental basis for design. Such models may include factors or assumptions with a research basis, but the fundamentals of the models were developed independently of actual operations and as such represent hypothetical measures. In some cases the models reflect general observations of an anecdotal nature, but lack any formal testing or validation through published research. (For example, selection of a maximum superelevation rate for curves is based on avoiding a vehicle sliding down a curve at low speeds or stopped when the pavement friction is very low, as would be the case under icy conditions. Such behavior is observable and explainable in engineering physics terms, but its relative frequency and severity has never been documented.)

Those geometric elements based on rational models have as their basic assumptions one or more of the following attributes:

- Hypothesized safety performance
- Hypothesized traffic operational performance
- Aesthetics

In some cases, most notably stopping sight distance, the basis for design values is a combination of a rational engineering model and empirical research to develop parameters of the model.

The matrix confirms that there is much technical dimensional guidance in the AASHTO Policy that is not based on empirical substantive safety or operational research, but rather on rational engineering models. Note that the relative importance of the models and geometric criteria vary widely.

The last column of the table provides a qualitative judgment of how important each criterion is with respect to the cost or impact on design and construction. For those criteria rated low, a simple hypothetical model may be sufficient and not in need of formal validation. (A separate issue to consider is whether the geometric guidance is really needed.)

The following summarizes the review of the AASHTO Green Book:

- 1) Design dimensions for many elements are based on simple and direct operational measures of vehicle dimensions and performance (e.g., off-tracking). AASHTO continually adds design vehicles. For such design elements and dimensions current policy guidance is sufficiently robust.
- 2) Certain key design elements that greatly affect the cost of the roadway are based on hypothesized simple models and not empirical research. This includes stopping sight distance, horizontal curvature, and width dimensions for roadways other than 2-lane rural highways. These are highlighted in the matrix.
- 3) Some criteria are based only on aesthetics. Although these have negligible influence on the cost of design, they are potential candidates for elimination as they may unnecessarily restrict the ability of designers to implement geometric solutions. As a minimum, should AASHTO retain these, it should be made clear that the guidance has no meaningful safety or operational basis
- 4) The operational and safety needs of pedestrians and bicyclists are not expressly addressed in the formulation of geometric design criteria. Lane and roadway widths for certain urban road types and contexts for both separate bike lanes and shared lanes are lacking. Current NCHRP research is addressing these gaps. Also, maximum grades for urban roadways in certain contexts should reference gradability of the road for cyclists.
- 5) Recommended level of service (LOS) policy for freeways in urban contexts is outdated. Urban freeway reconstruction carries the highest costs per mile, and as design LOS directly influences decisions on the sizing of such facilities, revising current published guidance is a critical need. Design for LOS E has been commonplace for over 20 years across the U.S. Indeed, LOS E is consistent with well-established design solutions such as HOV/HOT lanes and ramp metering. Design of such roadways should be included in the Green Book.

- 6) The current design speed model is vehicle centric and focused on directing designers to select a high enough speed such that speed-sensitive design dimensions will be properly designed. Criteria for selection of lower speeds as being consistent with a multi-modal and pedestrian-centric context are needed.
  - 7) Criteria based on hypothesized models that have been disproven or found not critical are candidates for removal or substantial change. Foremost among these is the guidance for selection of ramp design speeds. Cross slope rollover is another design criteria that should be changed based on actual research.
  - 8) The majority of design elements are context insensitive in their formulation and applicability. The prevailing variable in many of these is design speed, which presumably reflects the context. However, as noted above the design speed process itself does not satisfy all urban contexts. Context insensitivity also relates to the assumptions regarding the design vehicle and driver. For many design criteria the passenger car is assumed for all conditions and contexts.
  - 9) AASHTO has incorporated recent research to correct flawed hypothetical models and produce more reasonable design criteria. Examples include changes in the intersection sight distance models (based on gap acceptance studies), and updating the object height for stopping sight distance to represent a more realistic condition based on actual events. Research completed since the last edition should be referenced to update design of exit and entrance ramp terminals, and spacing between successive ramps on freeways.
- Following is a discussion of the individual geometric design elements of the policy.

## 6.2 Lane and Travelled Way Widths

Lane width criteria for two-lane rural highways were developed based on cost-effective analyses of safety and operational performance and initial construction costs (33). They reflect some consideration of the interactive effects of shoulder width. The research was based on older statistical methods for crash analysis and may warrant updating. Finally, the criteria as published in the Green Book are among the very few that differentiate roads to be reconstructed versus new roads.

Lane-width criteria for multilane rural roads and urban/suburban arterials do not reflect traffic volume sensitivities and are not based on explicit analysis of safety performance. The research basis for the HSM methods suggested no sensitivity of lane width to serious crash frequency or severity (although the lack of much mileage of multi-lane roads in rural areas with lane widths less than 12 feet makes firm conclusions difficult). Gaps in current knowledge are primarily associated with lane-width requirements and interactive effects of lane widths given incorporation of bicycle and transit lanes with general purpose lanes. This specific topic is being addressed in ongoing NCHRP Research.

Lane-width criteria for freeways per both AASHTO and FHWA remain fixed at 12 feet under all circumstances and traffic volumes. Interestingly, there are sufficient freeway segments in the United States with less than 12 feet of width (these would all have been constructed as design exceptions) such that statistically meaningful safety performance measures of varying freeway lane widths were able to be confirmed in the research that has become part of the HSM (17). Figure 40 shows the crash modification factor for lane widths, with 12 feet of width being the base condition.

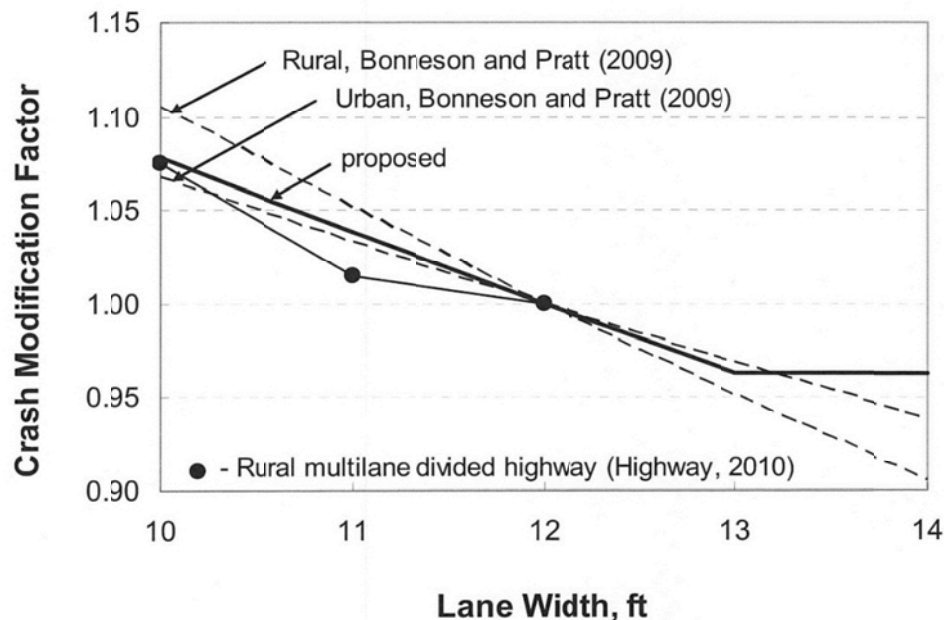

*Calibrated freeway lane width CMF for FI crashes.*

Figure 40. Crash Modification Factor for Lane Widths on Freeways. Source: HSM

Essentially, the examples of less than 12-foot lane widths are reconstruction projects, many of which included addition of general purpose lanes, managed lanes, or both within restricted right-of-way. Projects incorporating narrower lane widths continue to be proposed by agencies, approved by FHWA, constructed and operated in an acceptable manner demonstrates the reasonableness of dimensions less than 12 feet. The relatively modest difference in safety performance between 11- and 12-foot lanes confirms that they can be reasonable designs. The operational effects of varying lane width and shoulder width on freeway throughput are known and codified in the HCM, and these are similarly small in terms of the difference in performance. Moreover, the HSM research confirmed other research (34, 43) that documented a relationship between traffic density and crash frequency on freeway segments. Where narrower lane widths are used to enable the addition of a lane at little additional cost, the net safety effects may actually be positive, or at least negligible (i.e., the adverse effects of narrower lanes may be offset by the decrease in density that results in lower crash frequencies). Finally, it is noteworthy that Australian design policy allows for the metric equivalent of 11 foot lanes for lower design speeds on freeways (35).

To summarize, the application of less than 12-foot lane widths has become commonplace for high-volume urban freeways, despite the stated criteria in the AASHTO Policy. There is an adequate knowledge base on both safety and operations that would enable the development of a performance-based process and criteria with more flexibility to address limitations in right-of-way and high marginal costs of widening that are typical on urban and suburban freeways.

Table 19. Crash Modification Factor for Lane and Shoulder Widths

Lane Width (ft)	Shoulder Width (ft)			
	≥0 <2	≥2 <4	≥4 <6	≥6
≥9 <10	6.4	4.8	3.5	2.2
≥10 <11	5.3	3.7	2.4	1.1
≥ 11 <12	4.7	3.0	1.7	0.4
≥12	4.2	2.6	1.3	0.0

Table 20. Crash Modification Factors (CMF) for Shoulder Types and Shoulder Widths on Roadway Segments

Shoulder Type	Shoulder Width (ft)						
	0	1	2	3	4	6	8
Paved	1.00	1.00	1.00	1.00	1.00	1.00	1.00
Gravel	1.00	1.00	1.01	1.01	1.01	1.02	1.02
Composite	1.00	1.01	1.02	1.02	1.03	1.04	1.06
Turf	1.00	1.01	1.03	1.04	1.05	1.08	1.11

Note: The values for composite shoulders in this table represent a shoulder for which 50 percent of the shoulder width is paved and 50 percent of the shoulder width is turf.

Source: HSM Table 10-10

## 6.3 Shoulder Widths

Shoulder width criteria for two-lane rural roads were developed with the lane width criteria (33). For rural highways, the shoulder is the initial portion of the roadside, and criteria for shoulder width reflect research on the safety performance of roadside encroachments.

Some agencies employ shoulders on multilane suburban roads with higher volumes and in some cases with curbs. There is limited knowledge on the safety effects of shoulders in such cases, but this design practice is relatively uncommon in true suburban contexts.

Design criteria for shoulders and shoulder widths on urban freeways have been unchanged for many years. Current AASHTO criteria call for full shoulders (generally 10 feet or more) on the right, and 4 feet on the left or inside shoulder for four-lane freeways, and full shoulders for both sides on freeways with 6 or more lanes.

As with lane widths, the practice of accepting design exceptions for shoulder widths is commonplace and has increased in recent years. Agencies have treated shoulders as spatial opportunities to increase throughput with little or no expense. Some of the tradeoffs associated with such design decisions can be characterized objectively. The recent research on freeway crash prediction that is in the HSM provides safety performance functions (SPFs) for varying freeway cross sections and Crash Modification Factors for varying shoulder widths (18). The operational effects of shoulders with respect to throughput also are understood and codified in the HCM. Table 17 summarizes these two key sources of information on performance effects of varying shoulder widths.

Table 10 summarizes the O&M functions associated with shoulders, and the extent to which the shoulder width is critical to enabling these functions. Some functions require a full width (generally 10 feet or more), while others may be provided with lesser widths. For the latter, the value derived may be related to the width provided (e.g., a 6-foot shoulder provides more offset for roadside safety than a 3-foot shoulder), but any dimension provides some measurable value.

Some functions are important for all contexts (e.g., emergency access, law enforcement) and others only in some contexts (e.g., snow storage and removal). Also, the relative importance of all functions clearly varies by road type, context, and traffic volume. The ability to access crashes and incidents is greatly facilitated by full shoulders.

Road user benefits include reductions in non-recurring congestion, and survivability of crash victims by access to and egress from the site by fire, police, and ambulances.

Table 21. Effectiveness of Shoulder Widths for Shoulder Functions

Shoulder Function	Effectiveness for Given Width Condition	
	Partial (< 10 ft.)	Full (10 ft. or more)
Law Enforcement	None*	Yes
Emergency Stopping	None	Yes
Snow Storage	Yes	Yes
Ponding and water storage during intense rainfall	Yes	Yes
Roadway Capacity	Yes	Yes
Routine Roadside Maintenance	None	Yes
Roadside safety (Clear Zone)	Yes	Yes
Pavement Support	Yes	Yes
Maintenance of Traffic During Construction	Some (Depends on Total Width Available)	Yes
Provide Sight Lines to Vertical Obstructions	Yes	Yes
Incident Management	None	Yes

\* Some agencies use turnouts for enforcement

Agencies have ministerial duties to maintain roads in a reasonable state of good repair. Many maintenance activities involve the roadside, such as mowing, culvert cleaning and ditch maintenance, sign replacement and repair, utility maintenance, and guardrail and barrier replacement. The presence and available width of shoulders can greatly affect the ability and cost associated with routine maintenance activities. The maintenance and operational costs of either having full shoulders to work with, or having to close lanes (and often perform maintenance in off hours, and weekends) also will vary by road type and context.

Some functions requiring full widths (enforcement, emergency stops, and incident management) may be suitably accommodated by intermittent pull outs. In an urban design context such pull outs may be strategically placed wherever space is available within the right-of-way. This concept may provide some measure of value at minimal additional cost.

Finally, the ability to substitute ITS solutions for shoulder functions should be investigated. Managed lane facilities without shoulders are virtually impossible to enforce using conventional techniques, but automated enforcement using overhead cameras may enable an agency to no longer require or rely on shoulders as much as has been the case.

There is a great need for systematic research on the cost-effectiveness of shoulders and shoulder width dimensions on high-volume urban freeways. Such research would include full investigation of the operational and safety tradeoffs associated with narrowing lane widths. It also should include the relative effectiveness of intermittent turnouts as a substitute for full shoulders, including the frequency of such turnouts. This knowledge could serve to provide design guidance for projects in which alternatives to full shoulder dimensions are needed.

### 6.3.1 Framework for Design Criteria Development – Lane Width and Shoulders

Design values for lane width increased over the years as vehicle dimensions increased and speeds increased. For many agencies a 12-foot lane width is considered a standard minimum. As research has demonstrated, though, the contribution of incremental width to safety performance is minimal for certain road types (two-lane roads, freeways), and nonexistent for others (collectors, local roads, urban arterials). The incremental benefits of 12-foot versus 11-foot (or 11-foot versus 10-foot) lanes relate primarily to operational efficiency and capacity.

The basic principles of cost-effectiveness and knowledge of safety performance should produce lane width policy that properly recognizes the relative importance in transportation performance of lane width to other roadway features. Except for the highest class roadways in more rural, high-speed contexts, design policy should favor or promote the use of narrower lanes for the following reasons:

- The design width of lanes affects the entire length of the project, including right-of-way footprint and construction cost.
- Better uses for the additional one or 2 feet of lane width may be in shoulder width, provision of bike lanes, or greater offsets to roadside objects.
- To the extent that lane width influences driver speed behavior, design policy should promote the use of lane widths consistent with the desired speeds, which in many cases are lower.
- Every project ends by tying to an existing alignment and cross section. The agency may have no plans to reconstruct, the roadway for many years. A cross section with greater width in the middle of a roadway with lesser widths on either end may be more costly and produce counterproductive operations.

Figure 41 shows a strawman road type and context framework for lane width design criteria.

Roadway Type	Rural Natural Zone	Rural Zone	Suburban Zone	General Urban Zone	Urban Center Zone	Urban Core Zone
Local	Total road width based on operating characteristics of vehicle; 9 ft minimum lanes may suffice		10-ft minimum; additional width where bicycles are to be considered	10 to 11-ft widths; greater dimension where bicycles, on-street parking, bus and loading zones occur		
Collector	Total road width based on providing minimum LOS and reflecting expected crash risk; 10 ft lanes should suffice for most volume ranges		10- 12 ft; additional width where bicycles are to be considered	10 to 11-ft widths; greater dimension where bicycles, on-street parking, bus and loading zones occur		
Arterial	Range of 10 ft to 12 ft may apply based on volume, context (terrain, trucks, environmental); shoulder dimensions of 2 ft or more based on crash risk and maintenance costs		10- 12 ft; additional width where bicycles are to be considered	10 to 11-ft widths; greater dimension where bicycles, on-street parking, bus and loading zones occur		
Freeway	12 ft lane widths for most cases; in extreme context constraints 11-ft to 11.5 ft may be considered		12-ft lane widths; full right shoulders	11 to 12-ft lanes; consider total width of shoulders and develop optimal solution given right-of-way, maintenance and performance analysis		

Figure 41. Straw man Framework for Design of Lane Widths for Road Types by Context.

### 6.3.2 Local Roads in Rural Contexts

Local roads in rural contexts are low volume in nature and lower speed. Lane widths of 9 to 10 feet are sufficient. Operation of special vehicles such as agriculture combines may require greater widths, but these could include total width of roadway and shoulder; and may be limited to widening along curves.

### 6.3.3 Collector Roads and Arterials in Rural Contexts

Design criteria for lane and shoulder width as currently in the AASHTO Policy are based on performance-based analysis (33) The safety performance research basis preceded advances in methodologies for crash analysis that are prevalent in the HSM and now considered state-of-the art. Although the framework and approach reflect safety performance, there may be a need to update and potentially revise the findings based on current research best practices.

### 6.3.4 Urban non-freeway Roads

The regime encompassing all land use contexts for local, collector, and arterial road types should be viewed as inherently multi-modal in nature, with designer choices for many cross section features, including bike lanes, onstreet parking, medians, loading zones and transit stops. Cross section design in such cases can only be assessed holistically (i.e., by considering the width needs and interactive effects of the elements being considered). NCHRP Project 03-112 is just beginning. This project should address the knowledge gaps and provide performance-based input for such roadways.

The geometric design process framework should 1) acknowledge that lane widths above 12 feet provide no discernable safety performance benefits; 2) recognize that the availability of width for the roadway within the right-of-way will always be limited, requiring choices and tradeoffs; and 3) reflect the fact that lesser lane widths of 10 to 11 feet may provide substantial flexibility, enabling inclusion of other desired features.

### 6.3.5 Urban Freeways

Urban freeways carry a vastly disproportionate share of regional travel of all types. In virtually every major city, existing urban freeways operate at traffic volumes exceeding their design capacity. Despite published AASHTO guidance, urban freeway reconstruction projects are routinely undertaken in which the number of lanes is limited such that the design is LOS E, often through much of a typical day, for reasons of unavailable space and unaffordable costs. Indeed, the principle value of managed lane projects is on corridors in which operation at low levels of service is accepted because of context constraints. Current design policy per AASHTO and FHWA places strict limitations on lane width for freeways, with no allowance under policy for lane widths less than 12 feet. Of course, there are sufficient examples of freeway projects in which lesser lane widths have been constructed or reconstructed such that the relative safety performance of lane widths less than 12 feet can be assessed.

The design process for high volume urban freeways should allow for the evaluation of alternative cross section designs that include lane widths of less than 12 feet. There are quantifiable benefits associated with narrower lanes that include the ability to provide additional lanes within limited space, and the cost to reconstruct what are the most costly facilities in the highway system.

The ISATe HSM and 2010 HCM procedures reveal the relative value of different freeway cross sections using the same total width (lanes and shoulders) but allocating the dimensions such that one additional lane of travel is provided. Case study E in Chapter 7 is an example of a freeway where using narrow lanes and shoulders to allow an additional lane provides better performance.

Urban freeway corridor reconstruction projects can have initial capital costs on the order of \$50 million to \$100 million per mile. For a 10-lane segment with full shoulders (164 feet +/-), a reduction in lane width from 12 to 11 feet reduces the footprint by 10 feet, or 6 percent. The cost savings associated with such a design should be expected to exceed 6 percent given lessening of right-of-way effects and improved constructability. But even assuming only a 6 percent reduction, the savings can be \$3 to \$6 million per mile.

Although some new urban freeways are being planned, designed, and constructed, the vast majority of expenditures in the United States on urban freeways involve reconstruction. In many cases, agencies seek to add capacity for either general purpose traffic or managed (high-occupancy vehicle, tolled) traffic. As a matter of transportation policy, and depending on the problem(s) being addressed in the reconstruction of the urban freeway, either design solution may be considered optimal from a corridor, network, or regional perspective.



***A revised design process applied specifically for reconstruction of urban freeways should allow for the use of lane widths less than 12 feet, particularly in cases where additional freeway capacity can be provided without increasing the total width of the cross section.***

Given the ability to assess the operational and safety performance of an array of lane width values, there is no reason why the design process for urban freeways cannot promote and allow a site-specific analysis that allows for lane widths as low as 10 feet. The context of such a design is for freeway and freeway distributors in the urban core where speeds throughout the day may be 40 mph or less.

## 6.4 Roadside Design

Roadside design policy as described in the AASHTO Roadside Design Guide is based on safety performance research including traffic volume sensitivity. Indeed, it is AASHTO Policy and FHWA Policy that the selection and application of roadside design in the rural environment (clear zone and slopes) be determined on a project basis because of the wide range in contexts encountered.

AASHTO recently implemented further context sensitive changes to design policy on urban streets in the most recent updates. For urban conditions in which speeds are lower and right-of-way more limited, the current policy is based on safety performance research on the frequency and severity of impacts on roads with and without curbs. The criterion lateral offset with varying dimensions of a 2-foot minimum (between curb and object) and a 4-foot minimum (between edge of uncurbed travelled way and object) now forms the basis for roadside design on urban and suburban streets. Similarly, the criteria for placement and design of barrier systems are based on well-established performance criteria that reflect the vehicle fleet.

There are currently NCHRP projects investigating roadside design and roadside quantitative safety. NCHRP 17-54 *Consideration of Roadside Features in the Highway Safety Manual* and NCHRP 17-55 *Guidelines for Slope Traversability* are in progress. No recommendations are made for further research and development pending completion of these projects.

## 6.5 Alignment and Sight Distance

The design criteria that influence alignment – both horizontal and vertical – represent the greatest need for improvements to bring about a more cost-effective approach to road design. ***Two specific criteria represent the greatest opportunities – horizontal curvature and sight distance.***

### 6.5.1 Horizontal Curvature

Horizontal alignments consist of intersecting tangents (the point of intersection or 'PI'), with simple circular curvature providing a smooth pathway connecting the two tangents. The geometry of the circular curve is defined by the radius and central angle between the tangents. For any given radius, the greater the central angle, the longer the curve. Other geometric features include the superelevation, superelevation transitions, and spirals.

The primary design criteria governing horizontal alignment is the minimum curve radius, which is associated with the road's design speed and maximum superelevation, which is set by policy of the owning agency. According to AASHTO, maximum superelevation rates between 4 percent and 12 percent are allowable. Common practice among highway agencies is to use maximum rates between 6 percent and 8 percent for open, high-speed alignment.

In reference to Table 1, the following summarizes the current approach to design of horizontal curvature according to AASHTO:

- It applies consistently across all road types and contexts
- It is volume-insensitive (i.e., curves are designed the same regardless of the design traffic volume)
- It assumes passenger car operation and assumes the driver tracks the curve exactly as it is designed

- The model assumes constant speed (design speed)
- The model incorporates only radius of curve and not length (or central angle)
- Design policy considers curvature independent of other geometry (grade, cross section)
- Design policy assumes simple tangent-curve geometry (i.e., no spiral transitions)
- Design policy for the friction factor, which expresses the lateral acceleration is set by AASHTO, and varies with speed
- Although labeled as friction factor, the lateral acceleration component to the curve design policy is not based on measures of the tire/pavement interface, but rather on the comfort-based reaction of drivers tracking curves at varying speeds.
- The research basis for the comfort factor is field studies that are over 70 years old
- Design policy is independently established for a range of maximum superelevation values from  $e=0.04$  to  $e=0.12$
- Establishment of maximum superelevation values is assumed necessary to prevent a vehicle from sliding down a curve under icy (low pavement friction) conditions in stopped or low speed operation

#### 6.5.1.1 Critique of Current AASHTO Curve Design Model

The adoption of a comfort-based approach to curve design was made in the 1940s, predating all the research on safety and operations. It is consistent with the general design philosophy of the day and limitations in knowledge of the day. The vast majority of roads were two-lane rural. The research behind the model reflected the driving population and vehicle characteristics of the day (suspensions, weight, center of gravity, tires, etc.).

The rational model that assumes tracking the curve (center of lane) at the design speed was appropriate for the time, given the lack of knowledge on driver/vehicle behavior. However, it is impossible for a driver/vehicle system to track a curve as the model assumes. This would require an instantaneous steering behavior and vehicle response when the vehicle reaches the point of curvature (PC) and a similar response in curve departure at point of tangency (PT).

The model also is based on anecdotal evidence of vehicle behavior on superelevation on icy pavement. The risk of vehicles sliding down a curve has never been characterized in quantitative terms. This behavior is inherently low speed. It is associated with the exposure to icing conditions that vary greatly by context. Finally, the model ignores the potential interaction of grade with curvature on operations.

Research conducted in the 1980s characterized driver/vehicle behavior in the approach and tracking through the curve (36). Drivers on the tangent approach to an unspiralled curve are actually required to steer in the opposite direction of the impending curve to counteract the effect of the pavement rotation as superelevation is being developed on the tangent. Once at the PC, the alignment changes instantaneously from tangent to the full curve radius. As drivers cannot instantaneously steer this radius, but rather take some time to steer from a tangent to curve path, the path of the vehicle itself differs measurably from that described by the geometry of the curve. The actual path that is tracked is a spiral (which is mathematically defined as a curve for which the radius is changing at a constant rate). In the initial 100 to 150 feet of the curve, the path generates radii that are greater than that of the curve itself. Because such a path if not corrected would result in the driver running off the road, driver steering behavior corrects the vehicle path downstream of the first 100 to 150 feet. This corrective response results in the actual minimum tracked radius at some point having to be smaller than the road curve itself. This steering behavior was observed on hundreds of vehicles; it occurred within the lane that varied in width.

***All drivers operating on unspiralled, horizontal curves produce this behavior that was referred to as overshooting*** by Glennon et al. (36) In addition, the research demonstrated that the extent or severity of overshooting behavior (which would be an indicator of the responsiveness of the driver) is independent of the driver's selected speed. The net effect of this behavior is that drivers undergo significantly greater lateral acceleration, and

generate greater friction demand at the tire/pavement interface than the AASHTO design model assumes and the compensating effect of superelevation (assumed to be 1:1) is less than intended by AASHTO.

The extent to which driving curved alignment represents a greater challenge and higher risk to drivers means that the amount or length of alignment that is curved versus tangent may be of concern in design for horizontal alignment. The relevant geometric variable influencing the amount of curvature is the central angle between tangents. The relationships among central angle, radius, and length is shown in Figure 42.

Additional research performed in the 1990s characterized horizontal alignment in terms of risk associated with the number of curves and the sum of the central angles of the curves over a given length of roadway (37). This research reinforced the importance of not only the radius but also the central angle (or length) in curve design policy. As currently configured, AASHTO design policy does not explicitly recognize the risk associated with greater central angles, but rather focuses the designer's attention solely on the appropriate or minimum radius of curve for the design speed.

Another concern with respect to curve operations is the behavior of vehicles with high centers of gravity. Research has confirmed that trucks on curves will overturn at speeds lower than the critical skidding speed (38) – Moreover, the propensity to overturn occurs at speeds much lower than the critical skid speed for passenger cars. This explains the anecdotal evidence (yet to be quantified through formal research) that suggests that truck overturns on interchange loop ramps (which have very short radii and large central angles) are a recurring issue for many agencies. Finally, there is clear evidence of a dynamic effect associated with the combination of curvature and grade, such effect producing a greater adverse effect than would be expected.

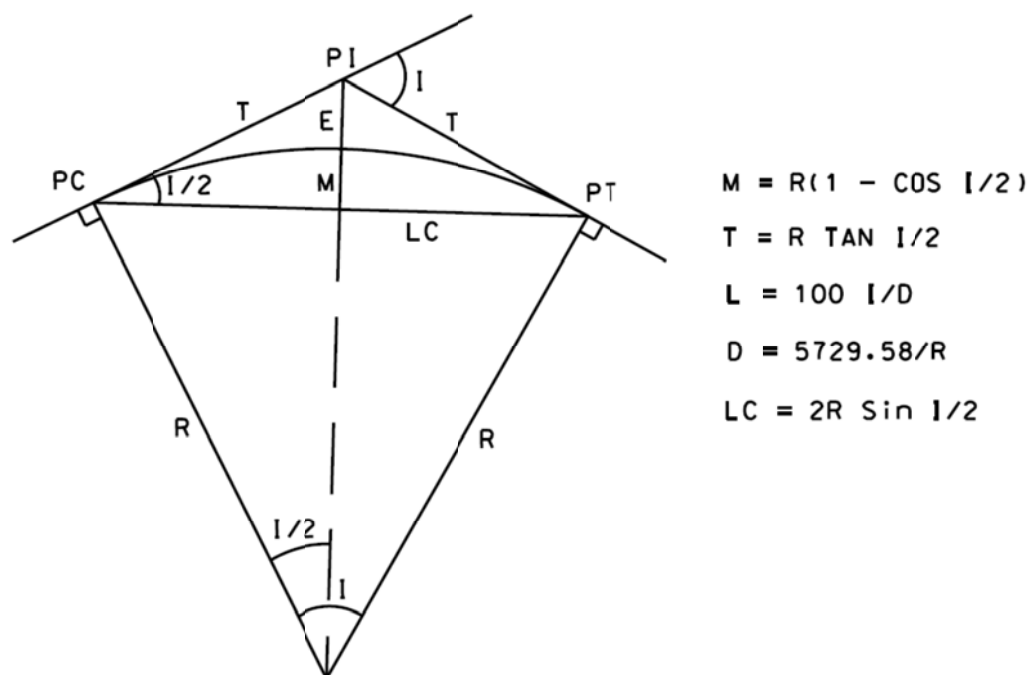

Figure 42. Curve Geometry

#### 6.5.1.1.1 Summary of Knowledge Base on Curve Operations

According to the HCM there is no direct effect of curvature on the speed or other performance measures such as density or LOS for any road type. An indirect effect associated with the terrain (level, rolling, mountainous) may be inferred, but this appears to mostly attributable to grade. The presence and length of upgrades and downgrades have measurable effects for which there are adjustment factors in calculations of flow rates and capacity, but no such adjustment factors exist with curvature.

There are anecdotal observations of curvature effects on speed and car-following behavior on high-volume urban freeways. The extent to which this can be characterized is a potential research area. Any meaningful effect on density and operations of high volume freeways should be included in derivation of design criteria for such facilities. Indeed, for very high volume freeways, it may be that the most important performance effect of curvature is on its effect on capacity, which could be translated to substantial user operating and travel time cost differences.

It also is established that vehicles (tires and brakes) undergo more wear on curved versus tangent alignments. The user costs over time of the vehicle types will be greater on alignment comprised of curves. Where isolated, curves represent limiting speed elements, differences in travel time may be associated to such curves when they occur on roads with higher free operating speeds.

#### 6.5.1.1.2 Summary of Knowledge Base on Safety Performance of Horizontal Curves

Curves have long been recognized as being overrepresented in crashes. Research now incorporated into the HSM provides a basis for understanding the safety performance of horizontal curvature (18). The following is basic background information that should inform a review and updating of horizontal curve design policy:

- The relative risk of a crash is a function of both the radius of curve and length of curve (or stated differently, the central angle of curve)
- Figure 43 shows the relationship of curve geometry and traffic volume to crash frequency risk for two-lane rural highways
- The interrelationship between curve geometry and roadside design (shoulder width and slope or barrier) to crash risk is significant; curve crashes are run-off-road by type and the outcome of the roadside incursion is affected by the quality of the roadside including the shoulder
- Spiral transitions have a small but significant positive effect on quantitative curve crash risk
- The effect of curve radius on crash risk is evident for two-lane rural highways and freeways, less so for multilane rural highways, and not apparent for urban arterials

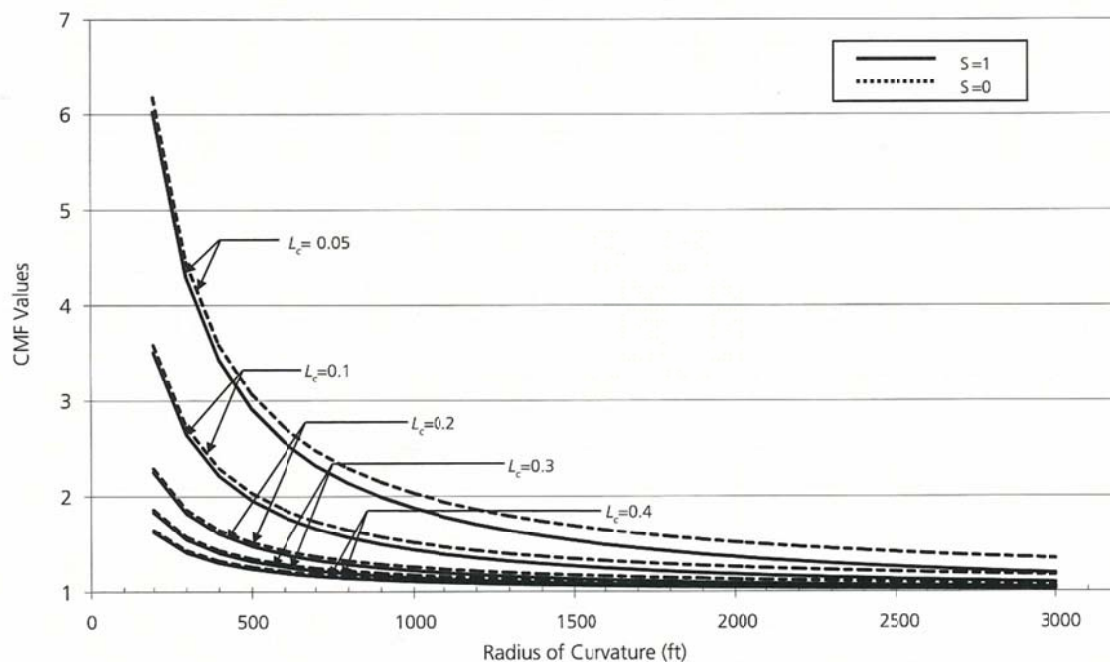

Figure 43. Potential Crash Effect of the Radius, Length, and Presence of Spiral Transition Curves in a Horizontal Curve

The manner in which the AASHTO model is applied to curve design policy produces inconsistent outcomes. This effect is based on the variance in maximum superelevation rates that are allowed by AASHTO. Curve design policy produces different designs for the same design speed. For example, for a design speed of 60 mph, the following are superelevation rates to be used for a radius of curve of 1600 feet for the range of  $e_{\max}$  policies per AASHTO:

$$e_{\max} = 4\% \text{ -- } 4\%$$

$$e_{\max} = 6\% \text{ -- } 5.6\%$$

$$e_{\max} = 8\% \text{ -- } 7.1\%$$

$$e_{\max} = 10\% \text{ -- } 8.1\%$$

In other words, a horizontal curve with identical horizontal geometry, that looks the same in all cases, and is intended to be driven at the same speed, is designed differently and hence feels differently to the driver depending on what state he/she is driving (i.e., on which superelevation policy is employed by that state's transportation agency). This inconsistent outcome of how AASHTO prescribes design of horizontal curves is illogical. Indeed, if superelevation is important, and the amount of superelevation for a given curve is important (which is confirmed in the HSM), it is hard to make the argument that the four design solutions noted above are equivalent.

The background presumption of setting maximum superelevation policy is based on the objective of avoiding sliding down an icy curve. This dynamic can be easily calculated for very low pavement friction values. However, this fundamental control in how curves are designed has never been objectively quantified; it deserves objective study. The type of event or collision is by definition low speed and hence low severity. Even in states with colder climates the majority of travel occurs on roads that are not icy or subject to this behavior, thus this is in most cases a low frequency occurrence. Given that research confirms a marginal benefit of *increased superelevation*, the overall risk in setting of design policy seems to be in providing not enough rather than too much superelevation.

#### 6.5.1.2 Context Insensitivity of AASHTO Curve Design

Perhaps the most significant concern regarding the AASHTO curve model is its context insensitivity. The model is applied identically across all road types and across all traffic volume ranges. Curves are designed the same, with the same costs incurred, regardless of whether the design year traffic volume is 500 vpd, 5000 vpd, or 50,000-vpd. A comfort-based operational model may be appropriate for two-lane rural highways, but a different model may be better suited to high volume freeways or lower speed and lower volume local roads. The marginal operational costs (safety, delay, vehicle operations) of one curve design versus another depend on the traffic volume exposure to the curve.

***The lack of a traffic volume exposure measure in horizontal curve design policy prevents the development of cost-effective alignment design, particularly in reconstruction settings, without having to resort to design exceptions.***

#### 6.5.1.3 Potential Approaches to Horizontal Curve Design Policy

Design policy for horizontal curvature should be thoroughly reviewed with new models and approaches proposed and tested. Measures of risk exposure per traffic volume and unique context features should be included. Differences in operational performance that may be present on different road types should be researched. The notion that the same design model should apply to all road types and contexts should be challenged. The following represents a straw man proposed structure that illustrates the breadth and depth of potential policy changes.

##### 6.5.1.3.1 Design of Curves on New Roads

Roads designed on new alignment should have a design policy that reflects our understanding of differences in operational and safety performance, and in the cost of construction based on the context (primarily location and terrain). Consider, for example, the following possible design policy framework for horizontal alignment, such framework representing a tailored approach to curve design as opposed to the singular one-size-fits-all approach per current AASHTO Policy:

- **Two-lane Rural Highways** – Design Policy for curves could be based on safety-effectiveness analyses of crash risk (which would reflect traffic volume and length of curve); operational effects (speed and capacity, vehicle operating costs, and travel time value); and construction costs associated with terrain. The assumption of design speed independent of adjacent alignment and grade could be replaced by use of iterative speed profile analyses. Design policy could potentially include incorporation of shoulder width and roadside as an interactive design feature (e.g., allowance for smaller radii with wider shoulders) and use of spirals (e.g., allowance for smaller radii if spirals are used). The basis for designing the combination of curves and superelevation could be revisited to eliminate the inconsistencies in outcomes noted above, with one set of superelevation rates developed for the full range of maximum superelevation up to 12 percent. Finally, the importance or criticality of truck operations on curves may apply in setting design policy to certain two-lane rural curves (e.g., those functionally classified as arterials with sufficiently high truck volumes).
- **Multilane Rural Highways and Freeways** – Based on safety-effective analyses of crash risk (which would reflect traffic volume and length of curve); operational effects (speed and capacity, vehicle operating costs, and travel time value); and construction costs associated with terrain. Policy could include specific analysis of trucks. Policy could include incorporation of shoulder width and roadside as a feature (e.g., allowance for smaller radii with wider shoulders) and spirals (e.g., allowance for smaller radii if spirals are used). For such highways, the notion of curve design policy based on truck operations may be appropriate.
- **Urban Arterials** – Based on vehicle tracking requirements and driver behavior of large vehicles (trucks, buses) when operating at the speed limit; operational analyses of capacity effects of curvature; safety effects of intersections with curves on approaches (human factors and safety studies)
- **Multi-modal Urban Arterials** – Based on vehicle tracking requirements and driver behavior of large vehicles (trucks, buses) when operating at the speed limit; operational analyses of capacity effects of curvature; safety effects of intersections with curves on approaches (human factors and safety studies); based on operating costs, requirements and characteristics of light rail, articulated buses and streetcar operations.
- **Urban Freeways** – Based on safety effectiveness of crash risk; and operational effects of curvature on uninterrupted flow under high volume conditions; and construction costs. Regarding operational effects, the influence of both horizontal and vertical geometry on throughput and capacity may be significant. For high volume freeways, the effect of milder curves and grades may compute to significant operational benefits over a 50 to 75 year project life. Such operational benefits also translate to safety benefits per the established relationship of crash frequency to volume to capacity ratio (v/c). Finally, effects of high volume flow pavement through curves (rutting, wear) on pavement life (maintenance costs) that may vary by curvature could influence urban freeway design criteria.
- **Interchange Ramps** – Based on safety effectiveness of crash risk; including potential interactive effects of grade and potential effects of truck safety performance on loop ramps; actual basis for loop ramp design may be truck operations, or may depend on the volume of trucks expected (e.g., through setting a forecast daily truck volume as a design policy threshold).

#### 6.5.1.3.2 Curves on Reconstructed Existing Roads

Design policy for horizontal alignment for reconstructed roads should follow the fundamental principle of addressing the problem. The problem may or may not be related to the cross section or alignment; and the problem may or may not be evident over the entire project limits. For example, the presence of curve geometry that does not meet design policy for new roads should not require such curve to be reconstructed to the new road policy nor require a design exception to justify not reconstructing the curve.

***To re-emphasize, existing curve geometry that does not meet current design criteria for new roads does not in and of itself constitute a problem.***

The policy for reconstruction should be structured to utilize the site-specific data (speeds, crashes by severity, other geometry, and road corridor context). The policy should be process based rather than dimensionally based. Consider the following possible geometric design policy framework:

- **Basic Problem is Operational** – If the problem being addressed is operational, and the nature of the operational problem is independent of the curve or curves, the policy should promote presumption of the adequacy of the existing geometry. If the curve or curves are part of the problem, the policy should outline 1) the specific performance measures to focus on; 2) solutions to improve performance that may include but are not limited to revisions to curve geometry; and 3) the diagnostic evaluation process to arrive at the optimal (most cost-effective) solution. For example, the combination of alignment and cross section may contribute to a high v/c ratio that produces low speeds and higher travel times. A single, sharp curve may create a bottleneck in an otherwise high-quality alignment. Operational models that predict the effects of increasing curve radius, widening lanes and shoulders through the curve, or both could serve as the basis for evaluating geometric design alternatives to the current alignment.
- **Basic Problem is Safety** – The policy should direct a safety performance analysis potentially employing the same models or methods used above in derivation of new alignment criteria. The quantitative safety models would be adjusted to incorporate site-specific data through Empirical Bayes or other methods. The process would include but not be limited to revisions to curve geometry. Shoulder and/or roadside improvements would be allowable without their being considered mitigation of a design exception. The cost-effectiveness analysis would include site-specific construction and right-of-way costs (this consideration alone would provide focus on the applicability of curve flattening as a potential solution). The design process for reconstructed curves may result in different outcomes than application of the new construction design criteria because of the influence of site-specific benefit estimates and cost calculations. Appendix C provides an example of a process to evaluate the curve design based on safety performance.

Central to the geometric design process for existing curves is the base condition, which is the existing curve itself, comprised of the radius, length, and central angle. The cost-effectiveness of any revised design is measured by the expected benefits (reduced crashes, lower operating cost) compared with the reconstruction costs of the alternative. As both benefits and costs are uniquely defined by the base condition, the geometric design process cannot rely on dimensional guidance, but rather must rely on a cost-effectiveness analysis process.

#### 6.5.1.3.3 Treatment of Curves on 3R Projects

A project for which the primary problem is infrastructure condition may still include consideration of design alternatives that address the curve geometry or cross section. The following process could be applied:

- **Site analysis demonstrates a Potential for Safety Improvement (PSI)** – An agency's HSIP or special safety program for curvature may not include a specific curve as its crash history does not reach the agency threshold; yet it may suggest a PSI. For 3R projects the presumption is that existing geometric features are adequate. Based on a curve-safety diagnostic review process, considering a full range of low-cost curve improvements that may include some geometric revisions, the 3R project may offer the opportunity to incorporate such improvements based on their expected benefit/cost analysis. Note that this process may apply on a site-specific basis, or through a systemic safety program implementation (x,y).
- **Site analysis demonstrates no Potential for Safety Improvement (PSI)** – Where site-specific data are such that the curve's PSI is zero, the 3R project should be performed without incorporating any improvements that would add substantially to the project's cost. An exception to this may be for agencies employing a systemic curve safety program that is typical for lower traffic volume roadways. Curves that fall within the guidance of the systemic program may have systemic improvements, which are by definition very low cost, included as part of the 3R project.

#### 6.5.1.4 Framework for Design Criteria Development – Horizontal Alignment

Given the wide range in context and in transportation priority based on road type, there is no reason to believe that a single model or approach for horizontal curve design will produce uniformly cost-effective or optimal solutions. The current horizontal curve design policy, which is based on driver comfort, is context insensitive (i.e.,

applies to all road types and all terrain); is volume insensitive, based on outdated research, and applies to both new design as well as reconstruction.

There are multiple rational approaches to design for horizontal alignment, any of which may produce cost-effective solutions reflective of the context and project type.

<b>Functional Basis for Curve Design</b>	<b>Design Vehicle Assumption</b>	<b>Speed Input Assumptions</b>	<b>Potential Geometric Interactions</b>	<b>Comments</b>	<b>Research Issues</b>
Driver Comfort	Passenger Car	Requires Design Speed Assumption	None	Current AASHTO approach; requires updated data and model	Replicate studies using current vehicles and drivers; or potentially use SHRP2 naturalistic driver database
Vehicle Overturn Potential	Single Unit or Semi-trailer	Requires Design Speed Assumption	Could be combined with grade	May be appropriate for Special purpose roads, loop ramps, or roads with high proportion of large vehicles	Determine relationship of curvature to overturn risk
Driver Loss of Control	Passenger Car	Requires Design Speed Assumption	Could be combined with grade	Apply models of actual driver behavior through curves; establish margin of safety for range of pavement friction based on studies or agency policy	Apply models of vehicle path and speed behavior (validate and update); potentially use SHRP2 naturalistic database; collect pavement performance data
Off-tracking of Critical Design Vehicle	Semi-trailer or other long vehicle	None -- would by definition apply to low speed roads with minimal risk of severe crashes	Could be combined with roadway or lane width	May be appropriate for very low speed and/or low volume roadways	Develop radius and width for low speed turns based on AUTOTURN or other computer models
Off-tracking at speed of Frequent Design Vehicle	Bus, semi-trailer or single unit truck	None -- would by definition apply to moderate speed roads irrespective of speed	Could be combined with roadway or lane width	May be appropriate for collectors and urban arterials up to 40 to 45 mph	Confirm and validate insensitivity of horizontal curvature to crashes on urban and suburban arterials; Conduct field studies observing offtracking at moderate speeds
Cost Effectiveness Analysis; Quantitative Safety and Operating Cost vs. Construction and Maintenance Cost	None	None -- process tests incrementally larger radii curves for their quantitative benefits	Could be combined with shoulder width and roadside; automatically incorporates radius and length (or central angle)	May be appropriate for 2-lane highway reconstruction projects	Model operating costs (fuel consumption, wear and tear); incremental safety benefits using HSM models for various road types)
Cost Effectiveness Analysis; Quantitative Safety and Operating Cost vs. Construction and Maintenance Cost; including effects of curvature on capacity and throughput	None	None -- process tests incrementally larger radii curves for their quantitative benefits	Could be combined with shoulder width and roadside; automatically incorporates radius and length (or central angle)	May be appropriate for reconstruction of high volume urban freeways	Model operating costs (fuel consumption, wear and tear); incremental safety benefits using HSM models for various road types); study effects of curvature on capacity and include these

Figure 44 shows the AASHTO design approach and others that may be considered the basis for more performance-based design of curves.

<b>Functional Basis for Curve Design</b>	<b>Design Vehicle Assumption</b>	<b>Speed Input Assumptions</b>	<b>Potential Geometric Interactions</b>	<b>Comments</b>	<b>Research Issues</b>
Driver Comfort	Passenger Car	Requires Design Speed Assumption	None	Current AASHTO approach; requires updated data and model	Replicate studies using current vehicles and drivers; or potentially use SHRP2 naturalistic driver database
Vehicle Overturn Potential	Single Unit or Semi-trailer	Requires Design Speed Assumption	Could be combined with grade	May be appropriate for Special purpose roads, loop ramps, or roads with high proportion of large vehicles	Determine relationship of curvature to overturn risk
Driver Loss of Control	Passenger Car	Requires Design Speed Assumption	Could be combined with grade	Apply models of actual driver behavior through curves; establish margin of safety for range of pavement friction based on studies or agency policy	Apply models of vehicle path and speed behavior (validate and update); potentially use SHRP2 naturalistic database; collect pavement performance data
Off-tracking of Critical Design Vehicle	Semi-trailer or other long vehicle	None -- would by definition apply to low speed roads with minimal risk of severe crashes	Could be combined with roadway or lane width	May be appropriate for very low speed and/or low volume roadways	Develop radius and width for low speed turns based on AUTOTURN or other computer models
Off-tracking at speed of Frequent Design Vehicle	Bus, semi-trailer or single unit truck	None -- would by definition apply to moderate speed roads irrespective of speed	Could be combined with roadway or lane width	May be appropriate for collectors and urban arterials up to 40 to 45 mph	Confirm and validate insensitivity of horizontal curvature to crashes on urban and suburban arterials; Conduct field studies observing offtracking at moderate speeds
Cost Effectiveness Analysis; Quantitative Safety and Operating Cost vs. Construction and Maintenance Cost	None	None -- process tests incrementally larger radii curves for their quantitative benefits	Could be combined with shoulder width and roadside; automatically incorporates radius and length (or central angle)	May be appropriate for 2-lane highway reconstruction projects	Model operating costs (fuel consumption, wear and tear); incremental safety benefits using HSM models for various road types)



<p><i>Cost Effectiveness Analysis; Quantitative Safety and Operating Cost vs. Construction and Maintenance Cost; including effects of curvature on capacity and throughput</i></p>	<p><i>None</i></p>	<p><i>None -- process tests incrementally larger radii curves for their quantitative benefits</i></p>	<p><i>Could be combined with shoulder width and roadside; automatically incorporates radius and length (or central angle)</i></p>	<p><i>May be appropriate for reconstruction of high volume urban freeways</i></p>	<p><i>Model operating costs (fuel consumption, wear and tear); incremental safety benefits using HSM models for various road types; study effects of curvature on capacity and include these</i></p>
--	--------------------	---	---	---	--

Figure 44. Potential Bases for Development of Horizontal Alignment Policy

**6.5.1.4.1 Alternative Design Vehicles**

For some road types or conditions, a larger vehicle may be more appropriate as the basis for design. Vehicles with high centers of gravity overturn before they skid. Loop ramps, or two-lane roads with high proportion of truck traffic; or truck-only facilities may be candidates for an operational model based on avoidance of overturning. Special purpose roads by definition may be designed explicitly for special vehicles such as agricultural or resource recovery.

The design vehicle characteristics of interest may vary. In some cases the off-tracking characteristics may be the controlling operational condition. In other cases, the speed at which overturn occurs for design vehicles with higher centers of gravity may control.

**6.5.1.4.2 Alternative Functional Basis – Loss of Control to Skidding**

As an alternative to driver comfort, curvature could be controlled based on providing a margin of safety against loss of control from skidding (many designers are under the impression that this in fact is the basis for AASHTO curve design). This approach would entail modeling of critical driver behavior based on research and studies of available pavement friction or established pavement performance policies of an agency.

For example, Glennon, et al. (36) demonstrated that passenger car drivers do not track curves as designed, but rather overshoot them (i.e., track a radius significantly smaller than the design). This overshoot behavior was found to be independent of the speed. Krammes et al (39) showed that the 85<sup>th</sup> percentile speed at which drivers track curves at speeds is significantly greater the AASHTO assumptions; with such speed behavior particularly variant in the 45 to 65 mph speed range.

For a given design speed, criteria for new or reconstructed roads could be developed to specifications reflective of the agency’s operating environment and policies:

- Select design friction supply associated with dry pavements in place (by road type if desired)
- Reduce the design friction supply if desired by the agency to reflect the significant frequency of wet or icy pavements, using historic weather records; and be consistent with the agency’s asset management policies and approaches related to pavement condition and skid resistance.
- Establish by policy a margin of safety threshold for the maximum design friction demand
- Select or establish the maximum superelevation for design policy
- Establish the design tracking percentile behavior (say, 95<sup>th</sup>) and calculate the path radius tracked for the range of design radii
- Compute the speed at which the margin of safety threshold is reached for the design tracking behavior, which becomes the nominal maximum design speed for the curve radius and superelevation.

As part of subsequent work in Phase II the above approach could be developed and compared to current design policy. This approach in all likelihood would allow for smaller radius curves, particularly on roads with lower design speeds. It is not clear what this approach may yield for higher design speeds. Clearly, the assumed friction and margin of safety will heavily influence the outcome.

**6.5.1.4.3 Alternative Functional Basis – Large Vehicle Offtracking**

For road types and contexts in which there is no evidence of operational or safety criticality related to curvature, the basis for curvature could simply be providing for the offtracking and turning of the most critical legal vehicles

that would use the road. Low volume roads and roads in low speed environments may be designed with this functional basis. Indeed, even higher class roads in urban environments may be designed using vehicle turning and offtracking characteristics. For higher type and higher volume roads, studies may be needed to characterize the paths drivers of such vehicles take at moderate speeds, to develop a policy that facilitates operation along curves under traffic. This approach also may be used to develop minimum roadway widths based on, for example, the total needs of design vehicles operating in opposing traffic.

#### 6.5.1.4.4 Alternative Functional Basis – Cost-effectiveness Analysis

Curve design for reconstruction of existing roads may be best determined through a cost-effective analysis that incorporates site-specific data and conditions. The existing alignment is the baseline condition; with traffic volume and composition, speed and crash history available for the analysis. Incremental flattening of the curve to different radii could be tested by modeling the operating benefits (vehicle operating costs and delay) and safety benefits (using an appropriate safety performance function (SPF) for curvature and empirical Bayes' methodology). The design approach could include the ability for the designer to test variances in shoulder width and road widening through the curve. The incremental construction and maintenance costs could be determined, and an annualized benefit/cost analysis performed using a suitably long project life (e.g., 50 years). The agency could establish by policy a level of benefit to cost that reflected their priorities and system affordability.

The cost-effective approach may appear involved, but it can readily be streamlined using tailored software. Moreover, it has the benefit of directly incorporating site-specific conditions that influence the cost. The benefits being directly related to traffic volume, it will produce different outcomes for lower volume than higher volume roads, all other factors being equal. The outcome by policy is one that reflects the known attributes of system performance and agency policies. Such a design outcome is exceptional rather than a design exception.

## 6.5.2 Summary of Revised Approach to Horizontal Curve Design

The above approach to design of horizontal curves represents substantial change over the current comfort-based, one size fits all approach. This approach will produce different solutions in different states and locations within a state, and outcome some may find difficult to accept. What must be understood is that the current process already produces different outcomes (based on different  $e_{\max}$  policies). The current process is based on an oversimplified operational model that ignores the effects of approach geometry on speeds, the combined effects of vertical alignment and cross section with curvature, and that does not differentiate vehicle types. Finally, the notion of comfort as a basis for investment and environmental impact decisions related to roadway design is inappropriate. Driver comfort when combined with the characteristics of vehicles and pavement conditions is presumably related to safety performance. The relationship, however, is tenuous, varies by context, and is a means to the ultimate end, which is safety and operational performance. The use of direct models, methods and measures of curve safety performance, including diagnostic approaches, when applied appropriately, should produce greatly improved performance and significant aggregate cost savings.

Figure 45 is offered as a straw man proposal to illustrate how design policy for curvature could be established within the recommended context proposal.

Roadway Type	Rural Natural Zone	Rural Zone	Suburban Zone	General Urban Zone	Urban Center Zone	Urban Core Zone
Local	Based on off-tracking requirements of larger design vehicles (nominal DS = 20 to 30 mph) or loss of control from skidding (DS = 40 mph)		Based on loss of control from skidding	Based on off-tracking requirements of typical large vehicles (perhaps vary by road type and context zone) at very low speeds; urban buses, single unit trucks, semi-trailers		
Collector	Based on loss of control from skidding					
Arterial	Based on volume-sensitive, cost-effective design criteria derived from safety performance, operating cost; and infrastructure life-cycle cost; include interactive effects of grade as appropriate		Based on loss of control from skidding	Based on off-tracking requirements of typical large vehicles (perhaps vary by road type and context zone) at moderate speeds		
Freeway			Based on volume-sensitive, cost-effective design criteria derived from safety performance, operating cost, and throughput/capacity; and infrastructure life-cycle cost; include interactive effects of grade; include consideration of decision or stopping sight distance limited by horizontal			

Figure 45. Straw man Proposal for Design of Horizontal Curvature for Road Types by Context

## 6.6 Sight Distance

The concept of sight lines providing sufficient distance to drivers to perceive and react to conditions ahead is a central requirement of geometric design. The following summarizes the current approach to design for sight distance in the AASHTO Green Book:

- There are four distinct type of sight distance – **stopping**, **passing**, **intersection**, and **decision sight distance**. These apply in varying ways to the roadway system.
- The functional models for each form vary, but all models have speed as a central parameter; and all models require assumptions about location of the driver’s eye, the object being observed, and the human driving response.
- Stopping sight distance (SSD) is the most fundamental type of sight distance. According to AASHTO, it should apply to all locations and road types (with the narrow exception of the sight distance at the approach to a signalized intersection).
- The AASHTO SSD model is a rational operational model. It applies equally to all roadways and contexts. It is volume independent and context independent.
- The SSD model assumes passenger car parameters, and operation at design speed.
- The passing sight distance (PSD) model is a rational operational model. It applies only to two-lane rural highways. Provision for geometry that provides PSD is not a requirement but rather a design choice that influences the operation (capacity) of the road.
- The ISD model is a series of rational operational models based on field studies of driver behavior and intersections with varying types of traffic control.
- The ISD model is context sensitive (i.e., it reflects the type of control, the design parameters of the intersection including number of lanes crossed or turning into, and grade).
- The decision sight distance model (DSD) is a series of rational operational models based on human factors studies of driver behavior.
- DSD is not a requirement but rather is recommended for certain specific contexts or conditions.

## 6.6.1 Critique of AASHTO Sight Distance Design Policy and Models

The fundamental concept of sight distance is applied in varying ways in design policy. Some types of sight distance are required (SSD and ISD) and others optional (PSD and DSD). SSD applies in all contexts and road types; the others (ISD, PSD, and DSD) apply only in certain specific cases. Per the above, SSD has the greatest influence on roadway design. The design of both horizontal and vertical alignment are directly influenced by the provision for SSD.

### 6.6.1.1 Stopping Sight Distance

The AASHTO SSD model was developed over 70 years ago and has remained essentially unchanged in its form since that time. The basic concept of the roadway providing sufficient sight lines for a driver to perceive and avoid a collision is fundamental. The execution of the concept requires either data or assumptions regarding the parameters of the design vehicle (height of eye, braking or steering capability), the driver (perception and reaction; braking or steering response), the conditions (assumed speed, pavement condition), and the nature of the event or object representing collision risk.

The AASHTO SSD model is simple in its construct. It was developed to fit the limited data and knowledge in existence in the 1940s. The SSD model recognizes speed as a basic parameter. It is context insensitive (i.e., it applies equally to all road types, and conditions, irrespective of traffic volume). Over time as changes in the vehicle fleet were observed, the inputs to the model were revised, but the model itself has remained unchanged.

Neuman, et al pointed out the shortcomings of the current model in a paper published more than 20 years ago (40). The authors proposed a risk-based framework for SSD design that included road type, traffic volume, and road context features. The model was described in theoretical terms; at the time the data and knowledge base for its development were lacking (The model was actually adopted by the authors of TRB Special Report 214 on 3R design criteria).

The AASHTO SSD model adopts a crash avoidance performance metric as its basis (vehicle must be able to come to a full stop to avoid striking the object in the road ahead). The consensus that has evolved in transportation policy regarding safety now focuses on avoidance or elimination of crashes that produce serious injuries and fatalities, and not total crashes. As noted previously, mandated advances in vehicle technology to improve safety performance have significantly changed the relationship between injury risk and speed of collision.

The principles associated with a risk-based SSD approach were alluded to in NCHRP Report 400 (3) and referenced in work for AASHTO on design criteria for VLVLRL. A maneuver sight distance (MSD) model was proposed for application to very low volume situations. The notion was that in low-risk cases, drivers need not necessarily come to a full stop to avoid collision; but rather could slow and maneuver around the object or problem. While this model also was theoretical, it is useful in that it challenged the conventional, simple AASHTO model.

The AASHTO SSD model is a simple human-factor based model that considers human response to perception of a conflict in the road ahead, and also relies on a human response mechanism (rate of deceleration or braking). The advent of eventual implementation of self-driving features in cars designed to perceive and adapt to risks is a long-term issue to consider.

Provision for SSD per the current design policy can have significant impact on reconstruction of existing rural roads. Designers and those responsible for design decision-making acknowledge that the SSD model is overly conservative. Crest vertical curvature, which is based on SSD, is among the most frequent design criteria for which a design exception is approved (15).

The AASHTO SSD model clearly has little applicability to the urban road context in which intersections are frequent, driveways frequent, and conflicts with crossing pedestrians and vehicles is the greatest risk factor. The majority of severe crashes are angle related or pedestrian related. For such facilities, the ISD model is more appropriate, and mid-block SSD as defined by an object in road is irrelevant for all but the most extreme terrain conditions.

### 6.6.1.2 Decision Sight Distance

Another aspect of the AASHTO sight distance policy is the extent to which the DSD criteria are generally ignored. Few agencies (Caltrans being a notable exception) adopt DSD as a design control comparable to SSD in its importance. The principle behind DSD is the provision of sufficient notice to drivers to enable them to make decisions and take driving actions. The decision-making and navigating tasks are more complex, take longer time, and require more sight distance to accomplish. The human response parameters input to DSD design were obtained from research in the 1970s and early 1980s. However, there is no direct evidence of the influence of DSD (or lack of DSD) on safety or operational performance of roadways. This is not surprising given the lack of direct evidence associated with the much shorter SSD dimensions.

Despite the lack of direct evidence, there is indirect evidence of the potential influence of sight distance on the operation of freeways. Lane changing and the intensity of lane changing (frequency over a given length of roadway) are associated with increased crash risk and reduced throughput. This knowledge base is associated with the measurable effects of weaving traffic and weaving sections on freeways.

The extent to which the presence or absence of DSD may influence the actual performance of lane changes is theoretical per the DSD model but yet to be quantified. Concentration of lane changing over shorter distances limited by lack of DSD may have a measurable effect compared with such lane changing occurring over greater lengths of roadway. High volume freeways (those with ADT in excess of 150,000 vpd) experience traffic densities consistent with LOS D to E throughout much of a typical weekday. Differences in the intensity of lane changing influenced by lack of DSD may potentially translate to observable differences in throughput, which in turn may be result in quantifiable operational benefits associated with DSD.

DSD is either important (i.e., it offers measurable performance benefits) or it is not as a design control. Most likely its importance is restricted to higher volume facilities operating at higher speeds. Proponents of DSD cite the human factors basis for DSD. Guide signing, and advances in GPS technology to aid navigation may mitigate or eliminate the need for DSD to be incorporated as part of geometric design. The extent to which providing DSD marginally increases the cost of a design, more observable and quantifiable benefits should be determined.

### 6.6.1.3 Passing Sight Distance

AASHTO recently revised the PSD model to reflect research that corrected the assumptions imbedded in the previous model with respect to the critical nature of the passing model. The revised model produces shorter passing zones than the overly conservative previous model. PSD applies only to two-lane highways.

Passing sight distance is somewhat unique in that it expresses or characterizes an operational attribute of the highway rather than a design requirement. Roads do not have to include passing zones, but the roads that include passing zones provide a higher LOS than those that don't. In this respect, PSD comes closest to a purely operational design criterion than others.

Table 18 shows the effect of No Passing Zones on the operation of a road, as published in the HCM. Designers may theoretically develop design alternatives that provide varying levels of PSD, measure the difference in LOS and travel time, determine the difference in costs, and make informed, optimization decisions on the objective operational and cost data.

Table 22. Effect of No Passing Zones

Opposing Demand Flow Rate, $v_0$ (pc/h)	Percent No-Passing Zones				
	≤ 20	40	60	80	100
FFS ≥ 65 mi/h					
≤ 100	1.1	2.2	2.8	3.0	3.1
200	2.2	3.3	3.9	4.0	4.2
400	1.6	2.3	2.7	2.8	2.9
600	1.4	1.5	1.7	1.9	2.0

800	0.7	1.0	1.2	1.4	1.5
1,000	0.6	0.8	1.1	1.1	1.2
1,200	0.6	0.8	0.9	1.0	1.1
1,400	0.6	0.7	0.9	0.9	0.9
≥ 1,600	0.6	0.7	0.7	0.7	0.8

#### 6.6.1.4 Intersection Sight Distance

ISD criteria were recently revised to reflect performance-based research (ref). The HSM suggests a relationship between ISD and safety performance for unsignalized intersections. Current models for ISD are focused on vehicle-vehicle conflicts, as defined by the duration of accepted gaps. The appropriate critical gaps for design was found in NCHRP Report 383 (42) to vary with the maneuver being made and the vehicle type making the maneuver. Research is currently underway in NCHRP Project 17-59 to determine a relationship between ISD and safety performance.

In urban contexts, particularly collector and arterial conditions with speeds in the 30 mph to 40 mph range, the frequency of potential crossing conflicts and demands on driver attention may present greater risks (or stated differently, longer driver reaction times) than is currently used. Providing continuous sight lines for drivers related to crossing conflicts (both at intersections and mid-block) may be the best performance basis for geometric design of urban roads and streets. Additional research is needed to confirm and quantify this issue.

#### 6.6.1.5 Maneuver Sight Distance

The concept of MSD was proposed as part of NCHRP Report 400 (3) on SSD. The concept was formulated to address the perceived low risk associated with full SSD for low-volume conditions. It expressed a sight distance necessary for a driver to perceive an object ahead, but rather than brake to a full stop, decelerate and maneuver around the object. The concept assumed that no opposing conflict was present and that the roadway (lanes and shoulders) provided sufficient space to allow for such maneuver. MSD was proposed as a reasonable basis for VLVRs (20). It is an example of a criteria developed to reflect variable levels of risk and preclude unnecessary greater dimensions for SSD.

### 6.6.2 Potential Approaches to Sight Distance Design Policy

As long as the human driver is a necessary element of operation on the road system, the principle of sight distance in some fashion is central to geometric design. What is needed is a more objectively variable set of criteria reflecting differences in risk associated with traffic volume, road type, speed, and circumstances along the highway. Indeed, the development of a unified sight distance approach seems appropriate. Figure 46 is offered as a straw man proposal for sight distance based on the recommended context framework.

Roadway Type	Rural Natural Zone	Rural Zone	Suburban Zone	General Urban Zone	Urban Center Zone	Urban Core Zone
Local	Maneuver Sight Distance (low speed and low volume)		Intersection Sight Distance; Speed Regime assumed by policy			
Collector	Risk-based Stopping Sight Distance (volume and roadway context sensitive); Passing Sight Distance for 2-lane and Intersection Sight Distance at Intersections					
Arterial			Risk-based Stopping Sight Distance (volume and roadway context sensitive)	Intersection Sight Distance; Speed Regime assumed by policy		
Freeway	Decision Sight Distance or risk-based stopping sight distance based on proven traffic operational and/or safety benefits of longer sight lines					

Figure 46. Straw man Proposal Framework for Design of Sight Distance for Road Types by Context

### 6.6.2.1 New Roads

Sight distance criteria for new roads may be developed using the above framework. In developing new alignments, the design task of balancing the earthwork required for horizontal and vertical alignment is such that providing marginally longer vertical curvature can often be done with little additional construction cost, at least for roads in level and rolling terrain.

The direct inclusion of traffic volume and risk relative to circumstances along the roadway could be translated into varying vertical curve lengths from basic (i.e., no unusual circumstances) to complex (potential conflict within the zone of limited sight distance). A skilled designer for new road alignment would have the flexibility to adjust the vertical alignment, or to relocate the potential conflict (intersection, driveway, horizontal curve) away from the zone of limited sight distance, allowing the use of a basic crest vertical curve. The tools of crash prediction and speed profiles/capacity would be applied to various designs, and quantities and right-of-way computed for each, enabling development of an optimal solution.

To the extent that availability of PSD, and DSD can be demonstrated by research, designers would have the information to test the addition of these at select locations, and perform the optimization.

### 6.6.2.2 Reconstructed Roads

The marginal costs of lengthening sight distance through alignment alternations is completely different in the reconstruction environment. Any change in horizontal or vertical alignment will typically be costly, and often include additional right-of-way. A central aspect of developing cost-effective solutions is linking the observed crash history with the presence and location of sight restrictions. Here, the use of SSD profiles as shown in Figure 47 becomes an essential tool. Where sufficient observed crashes coincide with the zone of limited sight distance, a designer has the necessary evidence to justify a design change and the attendant costs of it. As such evidence would be expected to be observed on higher volume roads, agencies would find themselves avoiding reconstruction to increase SSD on lower volume roads, and only on select higher volume roads for which the evidence of an SSD problem is translated to observed crashes.

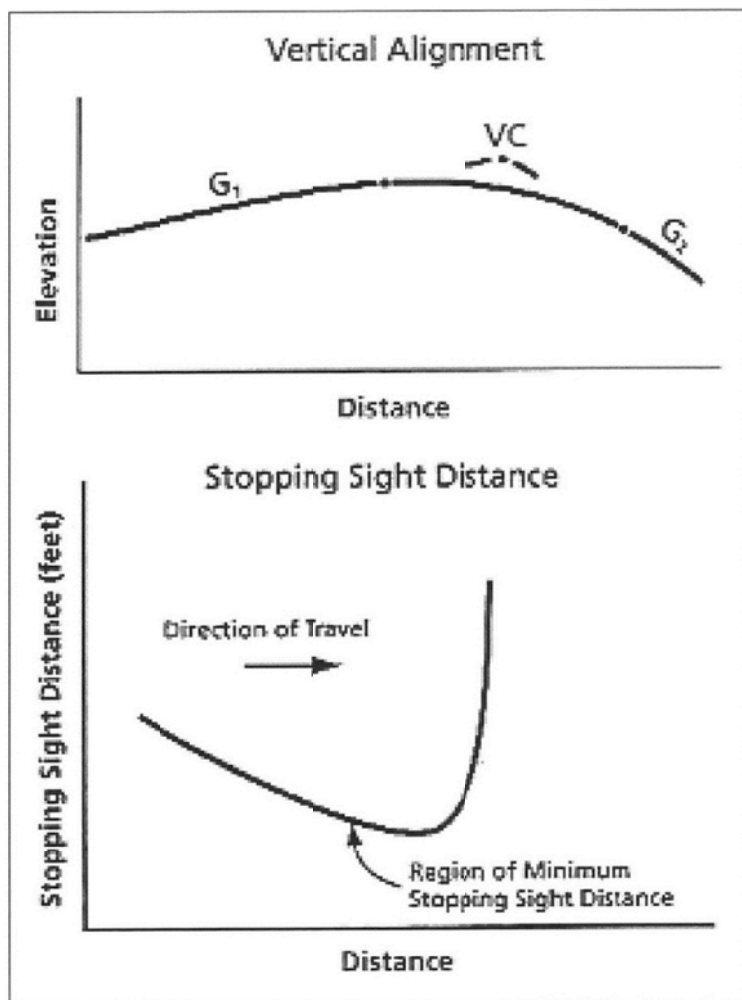

Figure 47. Stopping Sight Distance Profiles

## Source: HSM

### 6.6.2.3 3R Roads

Under the assumption that a project designated as 3R in nature is purely related to infrastructure replacement or repair, the only sight distance related improvements considered would include very low cost signing, striping, and lighting. Dynamic warning signs at intersections near sight restrictions may be considered, for example.

## 6.7 Vertical Alignment

Vertical alignment is comprised of tangent grades and parabolic vertical curvature. Grades are expressed as a percent, and vertical curves as crest (an upgrade followed by a downgrade) or sag (a downgrade followed by an upgrade). The engineering profession adopted the use of parabolic (as opposed to circular) vertical curvature because it facilitated the calculation of elevations to two decimal places in the field.

### 6.7.1 Grade

AASHTO road design policy considers the need for minimum grades and maximum grades for O&M reasons. Minimum grades (generally at least 0.3 percent) are intended to assure drainage of the pavement; such criteria apply to all roads in all contexts. Maximum grade criteria are set to enable operation of low-powered trucks carrying full loads. The performance criterion is the ability of a truck with a given wt/hp ratio to climb an upgrade.



The AASHTO criteria are sensitive to road type and terrain, but include no component of traffic volume. There is no reference to a design volume of heavy vehicles in the formulation of the criterion, nor is there reference to the length of the upgrade in the setting of the maximum grade criteria. Design policy does acknowledge the combination of grade and length of grade in determining need for auxiliary truck climbing lanes.

Current grade criteria are based solely on motor vehicle operations (passenger cars and trucks). Both steepness and length of grade substantially affect the operation of bicyclists.

### 6.7.1.1 Operational and Safety Effects of Grade

Most roadways are two way in nature, so the operational effects of grade differ by direction of travel. The exception to this is one-way roads, and one-way interchange ramps. The AASHTO Policy provides qualitative guidance on downgrade versus upgrade ramps, but does not offer definitive values, and does not differentiate between entrance and exit ramps with respect to desirable grades.

Grades have a quantifiable influence on the throughput of roadways as documented in the HCM. The determination of capacity uses the percent of heavy vehicles (although these are not specifically defined with respect to wt/hp ratio). As heavy vehicles slow on steep grades, the throughput of vehicles is reduced. This is expressed in the passenger car equivalents (PCE). The effect of grade on capacity varies by road type (two-lane rural highways, multilane roads, freeways), two-lane highways are shown in Table 23.

Table 23. PCEs for Trucks and Buses on Specific Grades

Downgrade (%)	Length of Grade (mi)	Proportion of Trucks and Buses			
		5%	10%	15%	≥20%
<4	All	1.5	1.5	1.5	1.5
4-5	≤4	1.5	1.5	1.5	1.5
	>4	2.0	2.0	2.0	1.5
>5-5	≤4	1.5	1.5	1.5	1.5
	>4	5.5	4.0	4.0	3.0
>6	≤4	1.5	1.5	1.5	1.5
	>4	7.5	6.0	5.5	4.5

Source: HCM, Exhibit 11-13

Grades also have a quantifiable influence on the safety performance of certain road types, including two-lane rural highways (Table 24). The effect of grade on urban and suburban arterials under most typical conditions has not been established. The effect of grade on safety performance of freeways and interchanges is suspected but not known, as this geometric variable was excluded in the research that developed the safety prediction models for freeways and interchanges for the HSM.

Table 24. Crash Modification Factors for Grade of Roadway Segments

Approximate Grade (%)		
Level Grade (≤ 3%)	Moderate Terrain (3% < grade ≤ 6%)	Steep Terrain (> 6%)
1.00	1.10	1.16

Source: HSM Table 10-11

The grade and length of grade has a substantial effect on the ability of bicyclists to use the road. Table 25, shows design criteria for grade for reasonable bicycle operations. For certain roads in certain contexts, the gradability of bicycle operations may be a suitable or even controlling basis for vertical alignment design.

Table 25. Bicycle Gradability

Grade	Length (feet)
5 to 6%	800
7%	400
8%	300
9%	200
10%	100
≥11%	50

Source: AASHTO Bike Guide 1999

### 6.7.1.2 Construction Costs and Grade

The construction cost of a new road is heavily influenced by the earthwork needed to construct the road. A fundamental design principle is to minimize the amount of earthwork, and balance the amount of cut and fill to eliminate the need to import or haul away earth. Assuming a given cross section, the primary geometric design means of cost minimization is through the use of grades to fit the terrain. It is common design practice for a preliminary alignment to be set, earthwork balances computed, and re-alignment performed as an iterative exercise to reduce the earthwork. This design exercise typically uses cross section templates that themselves are developed to minimize earthwork. Steeper cross-slopes for fill heights above certain dimensions are used, with flatter cross-slopes applied in more moderate terrain.

The above typical design practice commonly focuses only on iterating grades and vertical curvature to minimize the earthwork. The use of varying cross section templates also translates to different roadside designs, and specifically application of guardrail, barrier, and attenuation devices. Because such features in design are relatively small proportion of the initial construction cost, they are not typically included in the earthwork cost and design iteration.

The cost of hauling earthwork can vary widely based on the context. Factors include the availability of suitable sites near the project, the quality of available material, and the overall amount of material needed. Construction practices and costs have changed significantly over the years with the development of larger and more efficient earth-moving equipment. For rural roads on new alignment, the overall cost of earthwork is typically 15 to 30 percent of the total construction cost.

Reconstruction projects have less flexibility in design of grades than roads on new alignment. In most cases, the reconstruction design, which may include widening to add lanes, will closely follow the existing grades. Changes in vertical curvature and grade changes associated with re-alignment of the horizontal geometry may be made, but the reconstructed road will mostly follow the vertical alignment of the existing road. Significant grade changes over longer segments create problems in maintaining traffic flow and driveway or local road access to adjacent properties during construction, making such changes unusual.

## 6.7.2 Crest Vertical Curvature

The design basis for crest vertical curvature is provision for SSD. The AASHTO model for vertical curve design has remained unchanged since its inception. Vertical curves are designed to provide full SSD. The design parameters required to compute the necessary length include the design speed, the algebraic difference in the two grades, the assumed height of the driver's eye, and the assumed height of the object for which crash avoidance is the design objective.

The original model formulation in the 1940s was actually based on the concept of cost-effectiveness in design criteria. Figure 50 summarizes the SSD model applied to crest vertical curve length. The driver eye height was established through surveying the vehicle fleet in use at the time. The object height parameter (4 inches) was derived from studies of the marginal costs of earthwork as a function of varying object heights, with the lower boundary being zero. Changes in object height (from 4 inches to 6 inches) were made in conjunction with observed changes in the vehicle fleet over time that required a lowering of the eye height. The rationale by AASHTO was to maintain calculated vertical curve lengths, as there was no evidence of safety problems with the curve length criteria. *Contrary to the understanding of many engineers, the setting of object height was never intended to model any particular type of object until it was revised to 2 feet to account for taillight height.* It was derived as a mathematical solution to a cost-optimization problem.

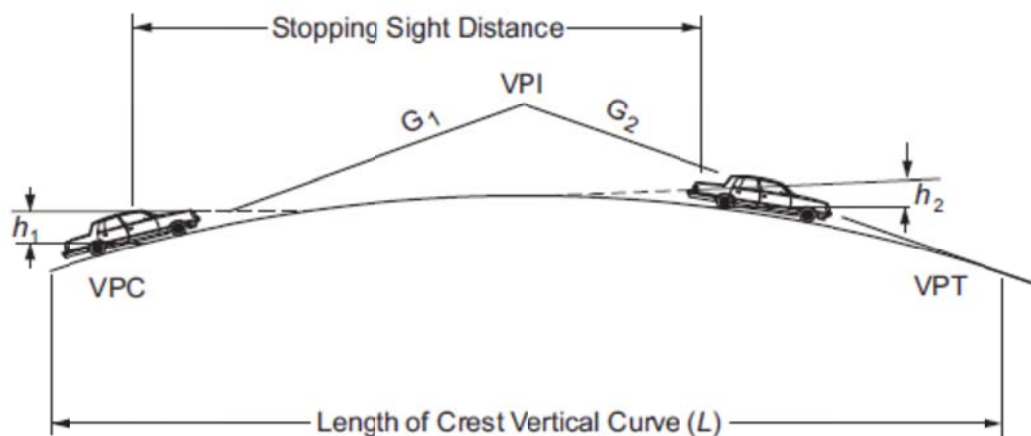

Figure 50. AASHTO SSD Model for Vertical Curvature Showing Eye and Object Height

Source: AASHTO Green Book

More recent research to update the AASHTO model confirmed its lack of a relationship between crash risk and the amount of SSD provided by the roadway geometry (3). Increasing the object height from its previous arbitrary 0.5 feet dimension to a 2-foot dimension addressed a portion of this issue, but the simplicity of the model and its lack of a traffic volume component to SSD design values call for a fresh look at SSD design. There was substantial resistance to the changes in AASHTO Policy to 2 feet from 0.5 feet by many who did not understand the original basis for vertical curve design.

SSD is volume, road-type and context insensitive. Vertical curve design is similarly insensitive to these considerations. Although designers may use longer than minimum SSD (just as horizontal curves milder than minimum controlling curves are used), the practice is unusual. A longer vertical curve may be used to lower a control elevation for an overcrossing structure, or perhaps to provide DSD, or to tie to another alignment such as a crossing facility at grade. Typically designers default to the minimum vertical curve length per criteria.

NCHRP Report 400 (3) recommendations were adopted by AASHTO. As a result, the minimum vertical curve lengths for design purposes are now shorter than previously. While this has reduced the number of vertical curves that may be considered substandard, there remain many miles of alignment for which vertical curve lengths do not provide minimum AASHTO dimensions.

### 6.7.2.1 Operational and Safety Effects of Crest Vertical Curvature

The geometry of vertical alignment produces greatly varying design outcomes for SSD. SSD profiles (Figure 50) are a useful, but not routinely used tool that show the amount of SSD provided by the vertical alignment at each location along the roadway. SSD profiles provide insights to the effects of a design. As drivers proceed on the

upgrade, the effect of the grade gradually reduces the amount of SSD provided. Just prior to reaching the crest of the vertical curve minimum, limiting amount of SSD per design policy is provided. Once the vehicle proceeds beyond the crest, the sight lines open up quickly and the amount of SSD increases rapidly.

The SSD profile is directional. The nature of the profile is defined by the relative difference in the two grades connected by the vertical curve. When a horizontal curve and roadside features coincide with the vertical curve, the sight line may be further affected. In such cases a three-dimensional sight line can be produced.

Although SSD profiles have been presented and discussed by AASHTO for many years, they are not routinely plotted nor studied as part of the preliminary design phase, despite the fact that the road design software used by most agencies allows for their automatic production. Even a cursory review of SSD profiles such as are illustrated in Figure 50 provides a number of important insights:

- The length of the road by direction along which actual minimum sight distance provided is relatively short; for much of the alignment more than minimum SSD is provided to the driver
- The location of the minimum sight distance by direction varies based on the grades and is unique to the context
- The nature of the roadway itself within the limits of minimum SSD should be of greatest concern to the designer

Regarding the last point, the presence of geometric elements that may pose a risk to driver behavior or operations (e.g., the PC of a horizontal curve, intersection or major driveway, bus stop, pedestrian crosswalk, narrow bridge approach) coinciding with the location of minimum SSD should be flagged by the designer as a condition to be redesigned.

Neuman et al (40) hypothesized that not all crest curves presented equal risk profiles in his construction of an alternative SSD design model. The risk associated with any crest vertical curve was asserted to be a function of core exposure measures including traffic volume, the amount of the sight restriction, the length of highway over which the sight restriction occurred; and the presence (or absence) of risk-increasing features.

Research on FHWA's 13 controlling criteria for design, presented in NCHRP Report 783 (41), confirmed that the relationship of SSD to safety is highly situational. The research examined the safety performance of Type I crest vertical curves (hillcrests) on rural, two-lane highways with SSD above and below the AASHTO SSD criteria and found that the presence of SSD below AASHTO criteria was not sufficient to produce elevated crash frequencies. However, when SSD limited the approaching driver's view of a critical feature, such as a horizontal curve, intersection, or driveway, elevated crash frequencies were observed. This illustrates that SSD is much more important to substantive safety at some locations than others. This situational variation in the importance of SSD should be considered in the geometric design process, particularly for projects on existing roads with proven safety histories.

Fambro et al. (3) demonstrated the lack of quantitative safety relationship in crest curve geometry. Others have shown some evidence of the added risk based on unique features within the crest curve as postulated by Neuman. Given the above insights and importance of SSD and vertical alignment, further research to characterize the relative risk of varying lengths of crest vertical curvature is considered a high priority.

Another consideration for crest vertical curves on low speed access roads, alleys and driveways where the control is to maintain enough clearance so the underside of a vehicle does not drag on the surface. The guidance such as that presented in NCHRP Report 659 (44) could be included in the revised process.

### 6.7.2.2 Sag Vertical Curvature

The design basis for length of parabolic sag vertical curvature has consistently been simple operational models. The primary basis is to provide a minimum length of curve such that a headlight beam can show the roadway ahead and provide SSD. For roadways that are lit, a secondary design control is to provide for a minimum length of sag curve based on studies of driver comfort. This secondary control produces minimum sag curve lengths of

about half the headlight beam dimension. As with crest vertical curvature, the design basis for sag vertical curvature is independent of traffic volume, road type, and context.

The geometry of sag vertical curves is rarely critical in alignment design. Designers can use vertical curves longer than the minimum, and many do so in situations where this improves the construction cost minimization or facilitates a vertical tie with another alignment. The most typical critical aspect of design for sag curvature is in managing drainage.

The rationale for the use of headlight beam distance as a key basis for sag vertical curve design is unclear. Headlight beam distance is irrelevant during daytime operations. At night, most drivers outdrive their headlight beam distance on level tangents (i.e., choose a travel speed at which SSD exceeds headlight beam distance), and presumably do so on sag vertical curves as well. Fambro's work in NCHRP Report 400, leading to the change to a 2-foot object height for SSD, representing the taillight height of a vehicle, suggested that the object that most needs to be seen by drivers on sag vertical curves will be illuminated (a special situation applies where an overpass structure is present on a sag vertical curve, as the structure will limit SSD).

There is no known nor hypothesized relationship between sag vertical curve length and crash frequency. There is a small but measurable effect of sag vertical curvature on the operating speeds of vehicles accelerating onto a relatively steep (greater than 4 percent) grade. Longer sag vertical curves provide better transition to the grade and aid in maintaining speeds as the vehicle begins natural deceleration on the upgrade. The combination of grade and length of grade represents operationally limiting geometry that may be a meaningfully, controlling feature of a design. A design criterion for sag curvature that involves longer than current design values may marginally but significantly influence throughput on roadways such as higher volume freeways operating near their capacity. This potential operational-performance criteria for such facilities bears further study.

## 6.8 Vertical Clearance

Vertical clearance is the dimension between the roadway surface and overcrossing structure. Sufficient clearance is necessary to enable legal-height vehicles to pass beneath the structure. Vertical clearance dimensions influence the vertical alignment or profiles of each roadway. The difference in elevation between the two roadways translates to earthwork and construction costs. The operational and cost effects of providing minimum vertical clearance dimensions can be multiplicative at system interchanges on freeways. The geometry and cost to construct four or five level interchanges is highly influenced by the vertical clearance dimensions employed.

The consequences of low vertical clearance are collision of the vehicle with the overhead structure. In most cases such hits involve overheight vehicles or those with improper loads, but while rare, such collisions can be catastrophic. In addition to creating a severe crash, such collisions can damage and in some cases destroy the bridge or require its complete reconstruction.

Legal height limitations vary by state and are in the range of 13.5 to 14 feet. AASHTO specifies a 16 foot minimum clearance dimensions for new structures. Many states apply criteria that add 0.5 feet to this minimum dimension to provide for future pavement overlays.

AASHTO allows for retention of existing structures for which the vertical clearance is less than 16 feet, with the lowest dimension allowable being 14 feet.

The 16-foot dimension originated with the 1956 Interstate System of Defense Highways Act. The design criteria were set to enable transport of military vehicles and equipment. This provision remains in force. There were many bridges built to lesser dimensions that became part of the interstate system. Even when reconstructed, lesser dimensions were retained because of the difficulty of revising crossing roadway vertical alignment and/or designing a bridge to a depth to allow the full dimension. States must either provide this dimension for all interstate highway bridges or provide an alternate route through or around a city that fully provides this dimension.

The full 16-foot dimension is no longer needed for the originally intended purpose. Vertical clearances of 15 feet adequately address the requirements of the legal vehicle fleet. The marginal costs of constructing bridges to 16 or 16.5 feet versus 15 feet are negligible; embankment costs and design complexity in setting the vertical alignment are the greatest potential savings. Also, where multiple levels are constructed the aggregate differences in cost may be somewhat greater.

The consequences of low vertical clearances would appear in databases showing bridge hit crashes and bridge repair records. The design process for reconstructed bridges or reconstructed roads with lesser vertical clearances should involve interrogation of such databases and, as necessary, interviews with agency staff to determine the actual risk of retaining lower clearances. The costs and difficulties of increasing clearance even by a foot or less can be substantial depending on the context.

## 6.9 Medians and Access Control

Current AASHTO design policy treats the presence and type of median as a necessary feature for fully controlled access facilities (freeways), but as a design choice for all other types. The types (raised, mountable, flush, and types of barriers used) and dimensions of medians may vary widely, with the width based on provision for other geometric elements such as shoulders and horizontal sight distance; and inclusion of other roadway functions such as drainage and locating overhead signs, lighting, and other similar structures. Medians serve to separate high-speed traffic, and enforce limitations or better facilitate access, and in particular left-turning access into and out of adjacent land uses.

There is substantial research on the safety performance of medians by their type and relationship to driveway and intersection frequency and level of traffic (18). The AASHTO HSM crash prediction methods include median presence and type as significant variables for all road types.

The trade-offs involved with median design decisions will typically include the relative safety performance vs. both inconvenience created by out of direction travel, and economic loss attributable to changes in accessibility to certain types of commercial land uses. Such trade-offs are generally associated with reconstruction projects, including conversion of one road type to another. Operational inconvenience costs to users are theoretically possible to model and quantify at the project level. Although research has been done on the effects of access management to business, the potential economic losses are less quantifiable on a case-by-case basis.

For roads on new alignment the marginal costs and benefits of including (or not) medians with given dimensions and type should be quantified and incorporated into design criteria for new roads.

## 6.10 References

1. Hauer, E., 'Safety in Geometric Design Standards,' 1999.
2. Neuman, T.R. et al., National Cooperative Highway Research Program Report 480, 'A Guide to Best Practices for Achieving Context Sensitive Solutions,' Washington, DC, 1992.
3. Fambro, D. et al., National Cooperative Highway Research Report 400, 'Determination of Stopping Sight Distances,' Washington DC, 1997.
4. American Association of State Highway and Transportation Officials, A Policy on Geometric Design of Highways and Streets, 2011 edition, Washington DC.
5. Harwood, et al., National Cooperative Highway Research Program Report 505, 'Review of Truck Characteristics in Roadway Design, Washington, DC, 2003.
6. Fitzpatrick, K. and Wooldridge, M., National Cooperative Highway Research Program, Synthesis Report 299, Washington, DC, 2001.
7. Ross, H.E. Jr et al., National Cooperative Highway Research Program Report 350, 'Recommended Procedures for the Safety Performance Evaluation of Highway Features,' Washington, DC, 1993.

8. American Association of State Highway and Transportation Officials, Manual for the Assessment of Highway Safety Hardware, 1st edition, Washington DC, 2011.
9. Transportation Research Board, Strategic Highway Research Program 2 (SHRP2), <http://www.trb.org/StrategicHighwayResearchProgram2SHRP2/pavement.aspx>
10. Association of Metropolitan Planning Organizations website: <http://www.ampo.org/resources-publications/best-practices/land-use-transportation-planning/>
11. National Conference of State Legislatures website: <http://www.ncsl.org/research/transportation/bicycles-and-pedestrians.aspx>
12. Glennon, J.C., 'Roadway Defect and Tort Liability,' Lawyers and Judges Publishing Company, 1996.
13. American Association of State Highway and Transportation Officials, 'A Guide for Achieving Flexibility in Highway Design,' Washington, DC, 2002.
14. Neuman, T.R. and Stein, W. 'Mitigation Strategies for Design Exceptions,' Federal Highway Administration, Washington DC, 2007.
15. Mason, J. M. Jr. and Mahoney, K.M., National Cooperative Highway Research Program Synthesis Report 316, 'Design Exception Practices,' Washington, DC. 2003.
16. Stamatiadis, N., et al., 'Design Exceptions and Safety,' Transportation Research Board 3rd International Symposium on Geometric Design, Chicago, IL, 2005.
17. Bonneson, J. A. et al., National Cooperative Highway Research Program Final Report for Project 17-45, 'Safety Prediction Methodology and Analysis Tool for Freeways and Interchanges,' Washington, DC, 2012.
18. American Association of State Highway and Transportation Officials, Highway Safety Manual 1st edition, Washington DC, 2011.
19. Transportation Research Board, Special Report 214, Designing Safer Roads, Washington DC, 1987.
20. Neuman, T. R., National Cooperative Highway Research Program Project 20-7, Task 75, Final Report, 'An Update to AASHTO's Guidelines for Geometric Design of Very Low-Volume Local Roads, Washington DC, 1999.
21. American Association of State Highway and Transportation Officials, Guidelines for Geometric Design of Very-Low-Volume-Local Roads (ADT < 400) 1st edition, Washington DC, 2001.
22. U.S. Government Accountability Office, Report GAO-15-33, 'DOT Has Opportunities to Improve Tracking and Reporting of Highway Spending,' Washington DC, October 2014.
23. Missouri Department of Transportation Website (<http://www.modot.org/>)
24. Federal Highway Administration Office of Innovative Project Delivery website: [http://www.fhwa.dot.gov/ipd/project\\_delivery/resources/cost\\_estimating/default.aspx](http://www.fhwa.dot.gov/ipd/project_delivery/resources/cost_estimating/default.aspx)
25. Institute of Transportation Engineers (ITE), 'Designing Walkable Urban Thoroughfares: A Context Sensitive Approach –ITE Recommended Practice,' Washington DC, 2010.
26. U.S. Government Office of Management and Budget website: <http://www.whitehouse.gov/omb>
27. Transportation Research Board, Highway Capacity Manual, 2010 edition, Washington DC, 2010.
28. American Association of State Highway and Transportation Officials, A Manual on User Benefit Analysis for Highways, 3rd edition, Washington DC, 2011.
29. Campbell, J. L. et al., National Cooperative Highway Research Program Project Report 600, Human Factors Guidelines for Road Systems, Second Edition, Washington DC, 2012.
30. Elvik, R. et al., 'The Handbook of Road Safety Measures, 1st and 2nd editions, (2004 and 2009).
31. Washington Department of Transportation website: <http://www.wsdot.wa.gov/Projects/ProjectMgmt/RiskAssessment/>
32. National Building Information Modeling Standards website: <http://www.nationalbimstandard.org/>

33. Zegeer, C.Z. and Neuman, T. R., National Cooperative Highway Research Program Project Report 362, 'Roadway Widths for Low Traffic Volume Roads,' Washington DC, 1993.
34. Lord, D. et al., 'Modeling Crash-Flow-Density and Crash-Flow-V/C Ratio Relationships for Rural and Urban Freeway Segments,' Accident Analysis and Prevention, 2004.
35. Austroads website:
36. <https://www.onlinepublications.austroads.com.au/collections/agrd/guides>
37. Glennon, J.C., Neuman, T.R. and Leisch, J.E. Safety and Operational Considerations for Design of Rural Highway Curves. Federal Highway Administration Report FHWA/RD-86-035, Washington DC, 1985.
38. Lamm, R. et al., Transportation Research Board, Record 1100, 'Comparison of Different Procedures for Evaluating Speed Consistency,' Washington DC, 1986.
39. Harwood, D. W. et al. 'Truck Characteristics for Use in Highway Design and Operation.' Reports FHWA-RD-89-226 and FHWA-RD-89-227. Federal Highway Administration, Washington DC, 1990.
40. Krammes, R. A. and Otteson, J. L., Transportation Research Board, Record 1701, 'Design Speed and Operating Speed in Rural Highway Alignment Design,' and 'Speed-Profile Model for a Design-Consistency Evaluation Procedure in the United States,' Washington, DC, 2000.
41. Neuman, T. R., Transportation Research Board, Record 1208, 'New Approach to Design for Stopping Sight Distance,' Washington DC, 1989.
42. Harwood, et al, National Cooperative Highway Research Program Report 783, 'Evaluation of the 13 Controlling Criteria for Geometric Design,' Washington, DC, 2014.
43. Harwood, Douglas W., Mason, John, Brydia, Robert, National Cooperative Highway Research Program Report 383, 'Intersection Sight Distance', Washington DC, 1996.
44. Harwood, D.W., K.M. Bauer, and I.B. Potts, Transportation Research Record 2398, "Development of Relationships Between Safety and Congestion for Urban Freeways," Washington, DC, 2013.
45. Gattis, J.L., National Cooperative Highway Research Program Report 659, Guide for the Geometric Design of Driveways, Washington DC, 2010





# 7 Value and benefits of improved process

## 7.1 Introduction

Work documented here has established that the geometric design process currently in use is insufficiently robust with respect to context; reliant on unproven, overly simplistic, or outdated models; and lacking in basic principles of cost-effectiveness in its applications. A revised process which is focused on problem solving using objective performance-based models and methods, and which recognizes inherent differences in project types and contexts, offers considerable benefits. The value and benefits of an improved process would hence appear to be as follows:

- There would be greater assurance that investments in infrastructure solutions requiring geometric design would produce actual performance enhancements commensurate with the implementation costs, such costs reflecting differences in the project context. Such assurance is particularly evident in the case of reconstruction projects, which form the increasing bulk of DOT project types. For such projects the revised process employs directly actual project data on operations and safety performance, as well as consensus science-based approaches to predicting future performance based on current knowledge and site-specific data.
- Conversely, the process applied properly would tend to preclude investments in geometric design solutions for which there is no evidence of performance improvements, thus producing savings to the owning agency. Geometric design as the means to an end (and not the end itself) is thus entirely focused on the specific nature and character of the site-specific problem. The more cost effective solutions should maximize safety and capacity benefits for limited funding resources.
- The process and design criteria employed, being based on research and data, would be self-reinforcing over time, thus ensuring the continued relevance and cost-effectiveness at a system level.
- Agencies would be able to control the application of the process to their projects at both the project and program levels, to reflect the current state of resources and competing priorities. Such control would occur through policy decisions on problem or needs definition, and threshold cost-effectiveness ratios, all of which may be adjusted based on resources available to the agency.
- The process if applied in its purest form would end the current uncomfortable and unproductive process of labeling a preferred solution as being or requiring a 'design exception.' Rather, it would stress the importance of arriving at an optimal solution given exceptional circumstances or context. This not only would reduce unnecessary bureaucracy, but would enhance public acceptance of agency actions and decisions.
- The process should reduce agency risk. The design exceptions process is inherently defensive in nature, and in many cases is a hindrance to arriving at the optimal solution. Design risk that exists today can occur if or when a design exception is missed. Maintenance of good records and decision documents will be more important with the proposed process. A focus on the documentation in a positive manner of the reasons behind the design decision (including calculations of relevant safety and operational elements) to assure they are done properly is a positive element of the process and should be the focus of the agency, rather than the exercise of explaining why something was NOT done.
- The process engenders trust within community that owner has engaged them, been transparent, thorough, and thus developed the best value solution. This will help agencies advance projects to implementation with less community resistance.

Agencies should expect that the process would, over time, produce higher quality projects (as measured by their resultant performance outcomes) at lower overall aggregate costs.

Agencies should expect to have to address important challenges. These are explained in detail in Chapter 8. However, one important challenge is worthy of note here when considering the above benefits to be expected.

The process if applied properly treats every geometric design project as unique. As such it requires the full attention and independent thought process for each project by the project's engineering team. Agency staff would no longer be able to hide behind the notion that 'Our Manual (or the Green Book) makes us do this.' Agency staff can no longer simply pull dimensions or values from tables or charts. The geometric design process, in becoming more performance-based in its approach, requires the application of more thorough thought and analytical approaches.

The above represent cultural (and to an extent, educational) challenges to agencies and their staffs. They should not increase project time, or even project development costs; but they will require different skill sets and re-allocation of agency resources to project development. In the end, the revised process should produce a more thoroughly professional and defensible outcome.

## 7.2 Case studies

In an effort to illustrate the application of the new process and to demonstrate the outcomes and benefits, the research team developed a number of "case studies". These illustrative case studies are hypothetical data, however, are the typical design scenarios that the designers face.

### 7.2.1 Case Study 1

*Addition of a bicycle lane on an urban arterial.*

Case Study 1 addresses an existing urban arterial street with one through lane in each direction of travel, a center two-way left turn lane, and on-street parking. The proposed project involves removing the center two-way left-turn lane and providing a bicycle lane in each direction of travel. The traffic operational and safety performance of Alternative 1 (the existing condition) and Alternative 2 (the proposed future condition) are compared.

Figure 48 shows typical cross-sections for the existing and proposed conditions of a 2-mi tangent segment of this urban arterial with an AADT of 17,800 vehicles per day (vpd) for the design year with the same total cross section dimension for both alternatives. For Alternative 1 (existing condition), a three-lane section with a center two-way left-turn lane is present, and a parking lane is provided on both sides of the road. Each travel lane is 12 ft wide, and the parking lanes are each 10 ft wide. For Alternative 2 (future condition), one through travel lane in each direction of travel is still provided, and bicycle lanes are also provided on each side of the road between the through travel lanes and the parking lanes. The through travel lanes are 11 ft wide, the bicycle lanes are 5 ft wide, and the parking lanes are 7 ft wide. The bicycle lanes are separated from the through travel lanes by a 3-ft buffer and from the parking lanes by a 2-ft buffer.

The 2-mi urban arterial segment includes two signalized intersections, at the endpoints of the segment, and three unsignalized (two-way stop-controlled) intersections within the segment, with a 0.5-mi spacing between intersections. The bicycle lanes will merge with the through travel lanes at the intersection approaches to allow for the provision of left-turn lanes. Therefore, the intersection design is the same for both existing and future conditions.

The left turn lanes at both signalized intersections have protected-permitted operation. The signals are uncoordinated; as a result, the optimal signal splits for each intersection are determined separately. Signalized pedestrian crossings are present on all four approaches of the signalized intersections. All of these intersection features apply to both the existing and proposed future conditions.

The side-street geometrics at both signalized intersections are identical and will not change as a result of the proposed project. The total width of the shared through/right-turn lane on the main street in the proposed future condition is 12 ft in the existing condition and 11 ft in the proposed future condition. However, for capacity calculations, the lane width was assumed to be 16 ft with a 6 ft paved shoulder. This accounts for the width of the parking lane, which does not extend up to the intersection, as well as the merging of the bicycle lane into the



Table 27. Case Study 1, Crash Study Results

Alternative	Predicted Crashes per mi per year		
	Total	Fatal and Injury	PDO
1	9.5	2.7	6.8
2	9.8	2.8	7.0

Predicted crashes were determined using HSM 1<sup>st</sup> Edition, Chapter 12 Worksheets (uncalibrated model without crash history data)

K = Fatal

A = Incapacitating Injury

B = Non-incapacitating Injury

C = Reported Injury

PDO = Property Damage Only

### Traffic Operational Analysis Results

Table 27 shows a comparison of the traffic operational performance or throughput for these designs, based on HCM methods and assumptions. The facility travel times and speeds are virtually identical between the existing and proposed future conditions and the levels of service are identical. The small increases in facility travel time are attributable to the decrease in width of the through travel lanes from 12 to 11 ft. The traffic operational analysis procedures for urban streets in the HCM do not address midblock delays due to removal of the center two way left-turn lane. The HCM procedures permit analysts to incorporate midblock delays manually, but only if estimates are derived from external sources, such as field studies. The HCM procedures also do not quantify the reduction in delay to motor vehicles by removing bicycles from the through travel lanes or the resulting improvement in traffic operational conditions for the bicyclists.

### Traffic Safety Analysis Results

Table 27 shows a comparison of the predicted safety performance (annual crashes) for the roadway segments between intersections for the design year, 2035. The following inputs were used in the HSM roadway segment analysis:

Table 28. Crash Analyses Input Values

Input Data	Alternative 1 (existing)	Alternative 2 (proposed future)
Roadway type (2U, 3T, 4U, 4D, ST)	3T	2U
Length of segment, L (mi)	2.0	2.0
AADT (veh/day)	17,800	17,800
Type of on-street parking (none/parallel/angle)	Parallel	Parallel
Proportion of curb length with on-street parking	0.75	0.75
Median width (ft) - for divided only	Not Present	Not Present
Lighting (present / not present)	Present	Present
Auto speed enforcement (present / not present)	Not Present	Not Present
Major commercial driveways (number)	2	2
Minor commercial driveways (number)	20	20
Major industrial / institutional driveways (number)	2	2
Minor industrial / institutional driveways (number)	20	20
Major residential driveways (number)	0	0
Minor residential driveways (number)	2	2
Other driveways (number)	0	0
Speed Category	Posted Speed 35 mph or higher	Posted Speed 35 mph or higher
Roadside fixed object density (fixed objects / mi)	10	10
Offset to roadside fixed objects (ft) [If greater than 30 or Not Present, input 30]	6	6

Note that all inputs to the Segment worksheet are identical for both alternatives, except that the roadway type changes from three-lane with a center two-way left-turn lane (3T) to two-lane undivided (2U). The small increase in predicted crashes for the proposed future condition shown in Table 26 results from the change in roadway type from 3T to 2U and the 1-ft decrease in through travel lane width. The HSM does not include procedures to quantify the effect on crash frequency due to the addition of the bicycle lanes, the narrowing of the parking lanes, or the addition of the buffer areas.

The Intersection Worksheet for HSM Chapter 12 was not used because the intersection design did not change between the existing condition to the proposed future condition, and therefore the predicted crash frequencies at each intersection would remain unchanged.

### **Conclusions**

The results of Case Study 1 provide an incomplete picture of the traffic operational and safety effects of the proposed project:

- HCM traffic operational analysis procedures indicate that narrowing of the through travel lanes from 12 to 11 ft has no substantive effect on the level of service for motor vehicles in the corridor.
- HCM analysis procedures cannot quantify the traffic operational effects of removing the center two-way left-turn lane or providing the bicycle lanes.
- HSM traffic safety analysis procedures indicate that removing the center two-way left-turn lane and narrowing the through travel lanes from 12 to 11 ft would increase roadway segment crashes in the corridor from 9.5 to 9.8 crashes per mi per year.
- HSM analysis procedures cannot quantify the effects on crashes of providing the bicycle lanes in each direction of travel, of narrowing the parking lanes from 10 to 7 ft, or of providing buffer areas between the through travel lanes and the bicycle lanes and between the bicycle lanes and the parking lanes.

Case Study 1 illustrates that substantial additions to the HCM and HSM procedures will be needed before a fully performance-based design process can be applied to a project like that considered here.

## 7.2.2 Case Study 2

### **Addition of a freeway entrance loop ramp to a diamond interchange**

A suburban interchange is being reconstructed to enable major development. Figure 49 shows the existing interchange alignment, and Figure 50 shows the proposed design alternative. The proposed design alternative includes a new entrance loop ramp in the southwest quadrant of the interchange, serving southbound traffic on the cross road entering eastbound on the freeway. This reconfiguration of the interchange removes the heavy left-turn movement on the southbound approach to the southern ramp terminal. The existing eastbound exit ramp and eastbound entrance ramp will be realigned to accommodate the new loop ramp. The predicted safety and operational performance of the existing interchange configuration and the proposed design alternative are compared for the design year.

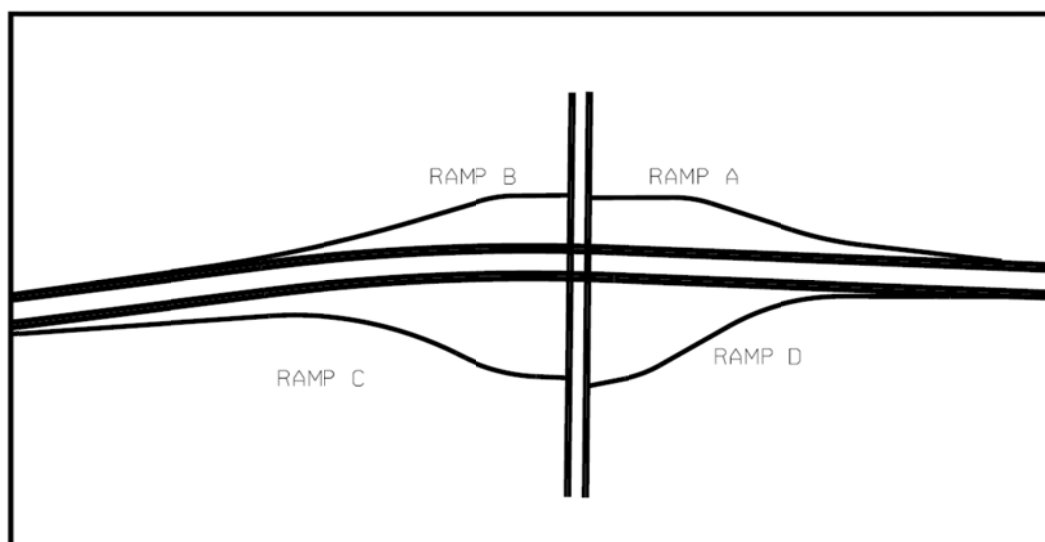

Figure 49. Existing interchange alignment.

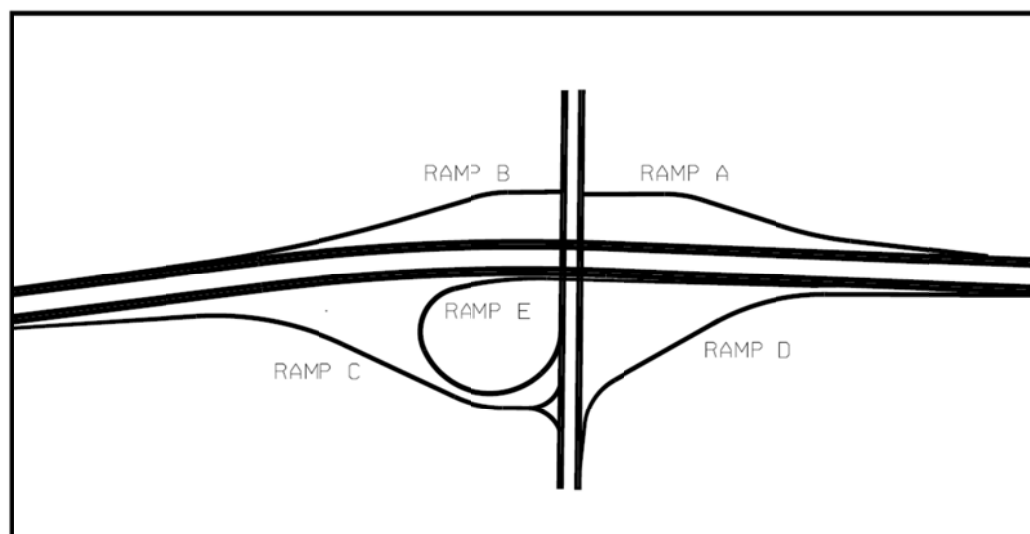

Figure 50. Proposed redesign of interchange, including new entrance loop ramp in southwest quadrant.

Free-flow speed on the mainline freeway is 65 mph. The design speed of the first curve off the interstate on the diamond exit ramps and the last curve on the entrance ramps is 60 mph. The design speed of the tightest curve on the loop ramp is 25 mph.

The freeway is on level terrain, and the traffic contains seven percent trucks and no RVs. The driver population factor is 1.00 since most of the drivers are regular users.

The freeway cross section includes three 12-ft lanes in each direction of travel, separated by a 28-ft median with a concrete barrier in the center. Rumble strips are present on the left and right shoulders except along speed change lanes for entrance and exit ramps.

The ramp terminals are signalized intersections. Left-turning maneuvers are assumed to be protected. In the existing condition, the southern ramp terminal operates as a 4-leg intersection, including the crossroad on the north and south side, the exit ramp on the west side and the entrance ramp on the east side. In the proposed condition, both the southbound-to-eastbound loop ramp and the northbound to eastbound diamond ramp leave the crossroad as a speed change lane upstream of the intersection. Only the exit ramp meets the crossroad at the signal. The existing three southbound through lanes between the northern and southern ramp terminal remain in

the proposed design, but the rightmost lane will be an exit only onto the new loop ramp, while the other two through lanes will proceed through the southern ramp terminal

In the existing condition, entrance ramps are two lanes at the crossroad ramp terminal that merge to a single lane prior to meeting the interstate. In the proposed interchange alignment, the eastbound entrance ramp becomes a single lane for its entirety. The proposed loop ramp is a single lane. Barrier is present along the outside of a portion of the loop ramp, and along a portion of the eastbound exit ramp.

In both the existing and proposed conditions, the westbound exit ramp leaves the interstate as a single lane and widens to two lanes before splitting to dual left turns and a right-turn lane at the crossroad terminal intersection. AADTs and peak-hour turning movement projections are shown for the existing condition in Figure 54 and for the proposed design in Figure 55. For the operational analysis, it was assumed that the freeway ramps upstream and downstream have no effect on lane utilization at the subject interchange.

For the operational analysis, the eastbound upstream entrance ramp design hourly volume is assumed to be 1,000 veh/h, and the downstream exit ramp design hourly volume is assumed to be 400 veh/h. For the safety analysis, all ramps within one-half mile upstream or downstream of the freeway analysis segment (not including ramps included in the analysis) have an AADT of 4,000.

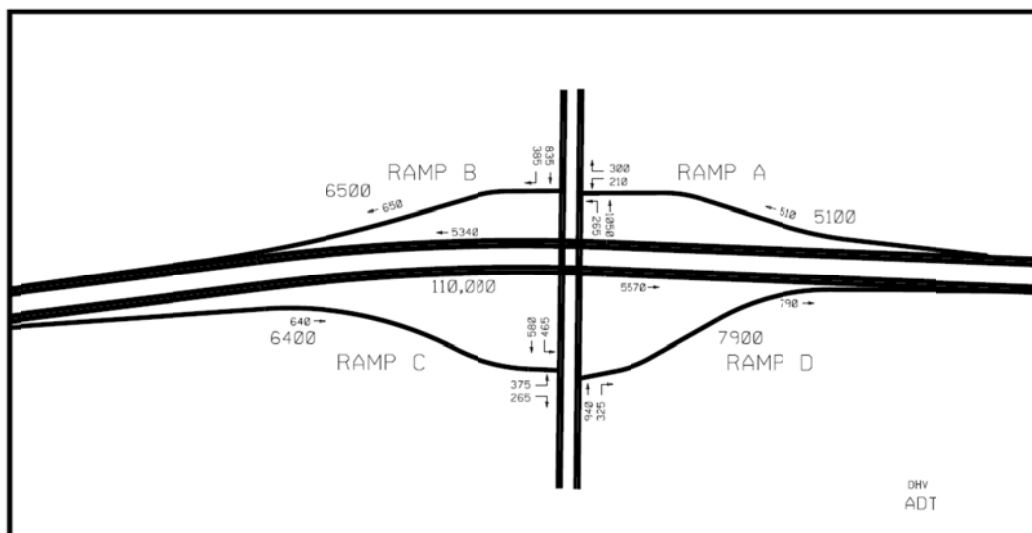

Figure 51. Design year traffic volumes for existing interchange configuration.

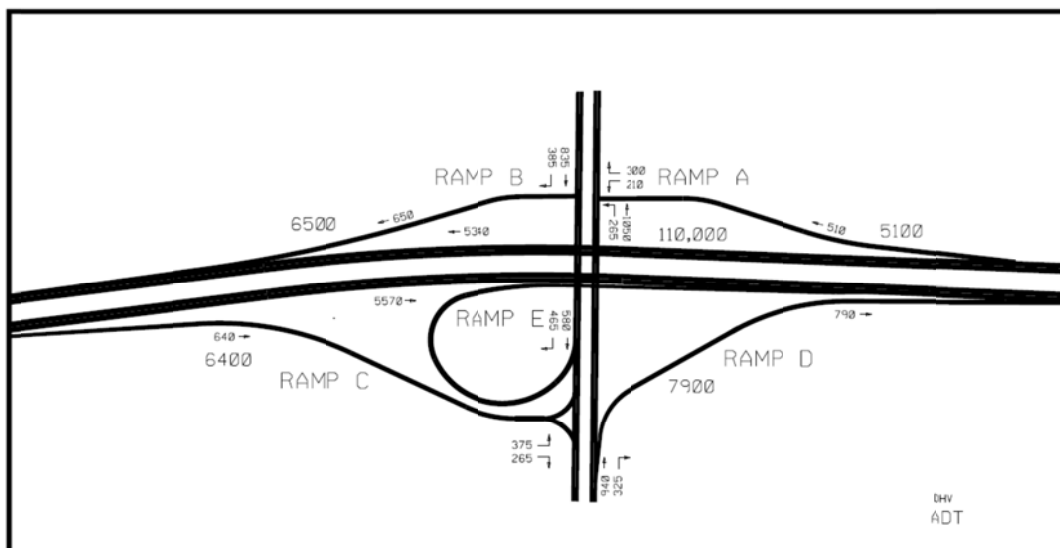

Figure 52. Design year peak hour turning movement counts for planned interchange reconfiguration.



### Traffic Operational Analysis Results

The HCS 2010 Freeway Facilities procedure was used to assess the LOS for the eastbound freeway mainline, as well as its individual components in the existing and proposed conditions for the design year. The analysis area started 2,000 ft upstream of the nearest entrance ramp to the east of the study interchange and ended at the nearest exit ramp west of the study interchange. The level of service results are shown in Table 29. Level of service, average travel time, and average travel speed for each analysis segment on the eastbound mainline freeway facility in the design year, 2025. along eastbound freeway in the analysis area.

Table 29. Level of service, average travel time, and average travel speed for each analysis segment on the eastbound mainline freeway facility in the design year, 2025.

Alternative	Segment	Level of Service	Avg. density (pc/mi/ln)	Avg. travel time (min/veh)	Avg. travel speed (mph)
Existing	1: begin to upstream entrance ramp	F	73.2	1.07	21.3
	2: upstream entrance ramp to Ramp C	E	47.9	0.33	44.8
	3: Ramp C to Ramp D	D	27.4	0.57	63.4
	4: Ramp D ramp beg to ramp end	E	35.7	0.27	56.1
	5: Ramp D ramp end to downstream exit	D	34.5	0.16	58.2
Proposed	1: begin to upstream entrance ramp	F	73.2	1.07	21.3
	2: upstream entrance ramp to Ramp C	E	47.9	0.33	44.8
	3a: Ramp C to Ramp E	D	27.5	0.32	63.3
	3b: Ramp E ramp begin to Ramp D entrance ramp begin	D	33.4	0.37	56.9
	4: Ramp D entrance ramp begin to ramp end	E	35.5	0.17	56.5
	5: Ramp D ramp end to downstream exit	D	33.8	0.16	59.3

Traffic operations at the ramp terminals were assessed with the HCM 2010 Chapter 18 and 22 procedures. The Chapter 22 procedures were used to calculate adjusted saturation flow rates for all lane groups at both ramp terminals, while the Chapter 18 procedures were used to optimize the signal timings. Common cycle lengths were chosen based on a target flow ratio of 0.85 for both ramp terminals so that the signals could be coordinated. Adjusted flow ratios and control delays were computed for each lane group. Then origin-destination control delays were computed for the interchange in order to determine LOS values.

The LOS assessment was based solely on volume-capacity ratios and control delays. It was assumed that the queue ratios would not cause any movements to operate at LOS F. Table 29 presents the control delay and LOS results for the ramp terminals for each movement through the interchange for both the existing and proposed conditions in the design year, 2025.

Table 29. Control delay and level of service for each movement at the freeway ramp terminals for existing and proposed conditions in the design year, 2025.

Traffic Movement through the Interchange	Existing Control	Proposed Control	LOS Existing	LOS Proposed
--	------------------	------------------	--------------	--------------

	Delay (s)	Delay (s)		
EB Freeway to NB Arterial	32.3	23.6	C	B
EB Freeway to SB Arterial	***	***	***	***
WB Freeway to NB Arterial	25.4	22.3	B	B
WB Freeway to SB Arterial	31.4	30.9	C	C
SB Arterial to EB Freeway	40.5	14.2	C	A
SB Arterial to WB Freeway	***	***	***	***
NB Arterial to EB Freeway	18.2	+++	B	+++
NB Arterial to WB Freeway	46.2	31.9	C	C
SB Arterial to SB Arterial	20.4	21.8	B	B
NB Arterial to NB Arterial	25.4	14.1	B	A

NOTE: all movements have v/c < 1.0

\*\*\*These movements are yield controlled

+++This movement is a free-flow ramp

The construction of the loop ramp will result in lower control delays for all movements at the ramp terminals, with one exception. (There was a very slight increase in control delay for vehicles traveling south along the arterial and not entering the freeway.) Level of service improved for some movements—most notably the southbound arterial to the eastbound freeway, which is served by the new ramp and improved from LOS C in the existing condition to LOS A in the proposed condition. No movement experienced a reduced LOS in the proposed condition. However, the addition of the loop ramp did not improve LOS scores for the freeway segments. Speeds downstream of the new ramp entrance were slightly higher, but not enough to impact LOS.

**Traffic Safety Analysis Results**

The safety analysis used procedures presented in Chapters 18 (Predictive Method for Freeways) and 19 (Predictive Method for Ramps) of the Highway Safety Manual. The elements included in the analysis were:

- A 1300-ft tangent freeway section extending from the location of the gore point of the proposed loop ramp on the west side to the end of taper of the proposed loop ramp on the east side (the length of the speed change lane for the planned loop ramp). The HSM procedure does not consider eastbound and westbound lanes separately—both directions of travel are considered together.
- The southern ramp terminal at the interchange
  - In the existing condition, a type D4 signalized intersection (four-leg ramp terminal with diagonal ramps).
  - In the proposed condition, a type A4 signalized intersection (four-leg ramp terminal at four-quadrant partial cloverleaf A). Note that the intersection actually operates as a three-leg intersection, and that both the southbound loop ramp and the northbound entrance ramp exit the crossroad using a speed change lane upstream of the intersection. However, the type A4 intersection was most appropriate for the analysis because it recognizes that there are no northbound or southbound left-turn movements at the ramp terminal with this configuration. The two entrance ramps are coded as having channelized right turns at the intersection.

- The ramps on the southern half of the interchange
  - In the existing condition, the eastbound diamond exit and entrance ramps
  - In the proposed condition, the eastbound diamond exit and entrance ramps as well as the eastbound loop entrance ramp

The safety analysis gave the following results:

Table 30. Crashes by segment type and severity level for existing conditions in design year 2025.

<b>Crashes by Facility Component</b>	<b>No. of Sites</b>	<b>Total</b>	<b>K</b>	<b>A</b>	<b>B</b>	<b>C</b>	<b>PDO</b>
Freeway segments, crashes:	1	7.5	0.0	0.1	0.5	1.4	5.4
Ramps, crashes:	2	1.2	0.0	0.0	0.2	0.3	0.8
Crossroad ramp terminals, crashes:	1	8.4	0.0	0.1	0.4	2.4	5.5
<b>Total</b>	<b>4</b>	<b>17.1</b>	<b>0.1</b>	<b>0.2</b>	<b>1.2</b>	<b>4.1</b>	<b>11.6</b>

Table 31. Crashes by segment type and severity level for proposed realignment in design year 2025.

<b>Crashes by Facility Component</b>	<b>No. of Sites</b>	<b>Total</b>	<b>K</b>	<b>A</b>	<b>B</b>	<b>C</b>	<b>PDO</b>
Freeway segments, crashes:	1	8.0	0.0	0.1	0.6	1.6	5.7
Ramps, crashes:	3	2.8	0.0	0.1	0.4	0.6	1.6
Crossroad ramp terminals, crashes:	1	13.6	0.0	0.2	1.1	4.4	7.8
<b>Total</b>	<b>5</b>	<b>24.4</b>	<b>0.1</b>	<b>0.4</b>	<b>2.2</b>	<b>6.7</b>	<b>15.1</b>

Despite providing a slight improvement in operations, the proposed interchange design results in an estimated 43 percent increase in total crashes (from 17.1 to 24.4). Most of the increase occurs in less severe crashes. The results can be explained as follows:

- Expected crashes on the freeway segment increase slightly as this segment changes from a 6-lane segment with no lane additions, drops, or speed change lanes, to a segment that includes an entrance ramp speed change lane along the entire segment in the eastbound direction. In the existing condition, no merging maneuvers are required through the segment, while they are required for traffic entering from the loop ramp in the proposed condition.
- Expected crashes on the ramps more than double, but the proposed interchange design adds a third ramp with tight, but variable, curvature.
- Expected crashes on the ramp terminal increase 62 percent (from 8.4 to 13.6). At first, this finding is counterintuitive, given that a heavy south-bound left-turn movement is removed from the intersection. However, in the existing condition, this left-turn maneuver is protected, reducing left-turning collisions. In the proposed condition, the entrance ramps are removed from the intersection by substantial channelization. Right-turn channelization has a CMF larger than 1.0 in the HSM, indicating that it leads to more crashes than the intersection would otherwise experience.

### Limitations

The safety analysis was simplified for the sake of this case study. It would have been more appropriate to consider the freeway segments upstream and downstream of the study segment to encompass the entire interchange area. This is especially true for the segment including the speed change lane on the northbound-to-eastbound entrance ramp. Because the volume on this ramp decreases with the addition of the loop ramp, it is likely that crashes along the freeway segment along the speed change lane would decrease and offset some of the increase seen in the segment included in this analysis (which included the speed change lane for the loop ramp in the proposed condition).

The proposed design of the southern ramp terminal didn't exactly fit any of the ramp terminal types available for analysis in the HSM. Specifically, both entrance ramps exit the crossroad via speed change lanes 100 ft or more upstream of the intersection and do not interact with any other intersection movements. Therefore the SPF and CMFs used in the analysis for a type A4 ramp terminal may not accurately describe what would be expected at this terminal.

While the configuration of the ramp terminal on the north side of the intersection didn't change, it's likely that it would operate differently once the southbound left-turn lanes were removed from the southern ramp terminal intersection.

In addition, it is unknown how the interchange reconfiguration might impact the overall volumes served at the interchange due to drivers currently using adjacent interchanges rerouting for improved convenience.

### **Conclusions**

The traffic operational analysis of the project found that the addition of the loop ramp would have very little effect of the LOS on the mainline freeway. This result was expected because the project adds a new mainline freeway ramp terminal, but the total volumes served by the ramps remain unchanged. The LOS for traffic movements at the individual ramp terminals either improved slightly or remained the same, but in several cases there were marked reductions in control delay at the ramp terms. Thus, overall, the project has a positive effect on traffic operations.

The traffic safety analysis indicates that the project would increase crashes in the analysis area by 43 percent, from 17.1 to 24.4 crashes per year. A small portion of this increase in crash frequency results from the addition of a new mainline freeway ramp terminal. Ramps crashes more than doubled (from 1.2 to 2.8 crashes per year) with the addition of the new loop ramp with a curved alignment. In addition, cross road ramp terminal crashes increased from 8.4 to 13.6 crashes per year with the addition of a new crossroad ramp terminal.

The project provides modest traffic operational benefits, but will result in a substantial increase in crashes. This result suggests that investigation of other alternatives for improvement of this interchange would be desirable.

Case Study 2 shows that the available HCM and HSM tools are well suited to evaluation of interchange improvement projects of this sort. Thus, performance-based approaches for evaluation and comparison of interchange improvement alternatives are a practical tool within the current state of the art.

### 7.2.3 Case Study 3

#### *Reconstruction (or 3R) Project on a Rural Two-Lane Highway*

Case Study 3 involves the assessment of a proposed reconstruction or resurfacing, restoration, and rehabilitation project on a rural two-lane highway.

Figure 53 shows typical cross-sections for the existing and proposed future designs for a 2-mi rural two-lane highway segment carrying 11,000 vehicles per day (vpd). Specifically, the existing 2-ft paved shoulders will be widened to 6-ft paved shoulders, and both centerline and shoulder rumble strips will be added. The 2-mi segment also contains three horizontal curves that will be flattened and combined into two curves with larger radii, as shown in Figure 54.

ADT = 11,000 vpd

Length = 2 mi

DHV = 700 SB/400 NB

Trucks = 2%

PHF = .90

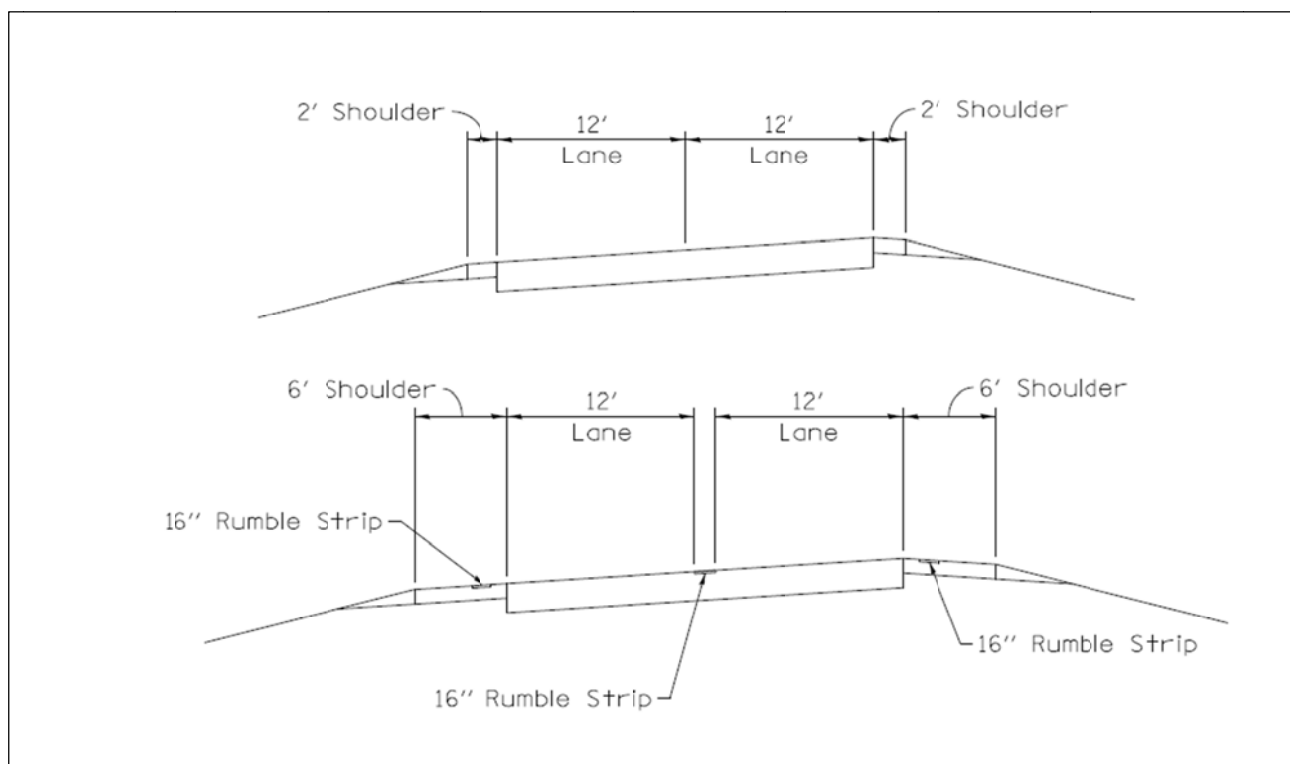

Figure 53. Cross-section before 3R improvement (top) and cross-section with improvement (bottom)

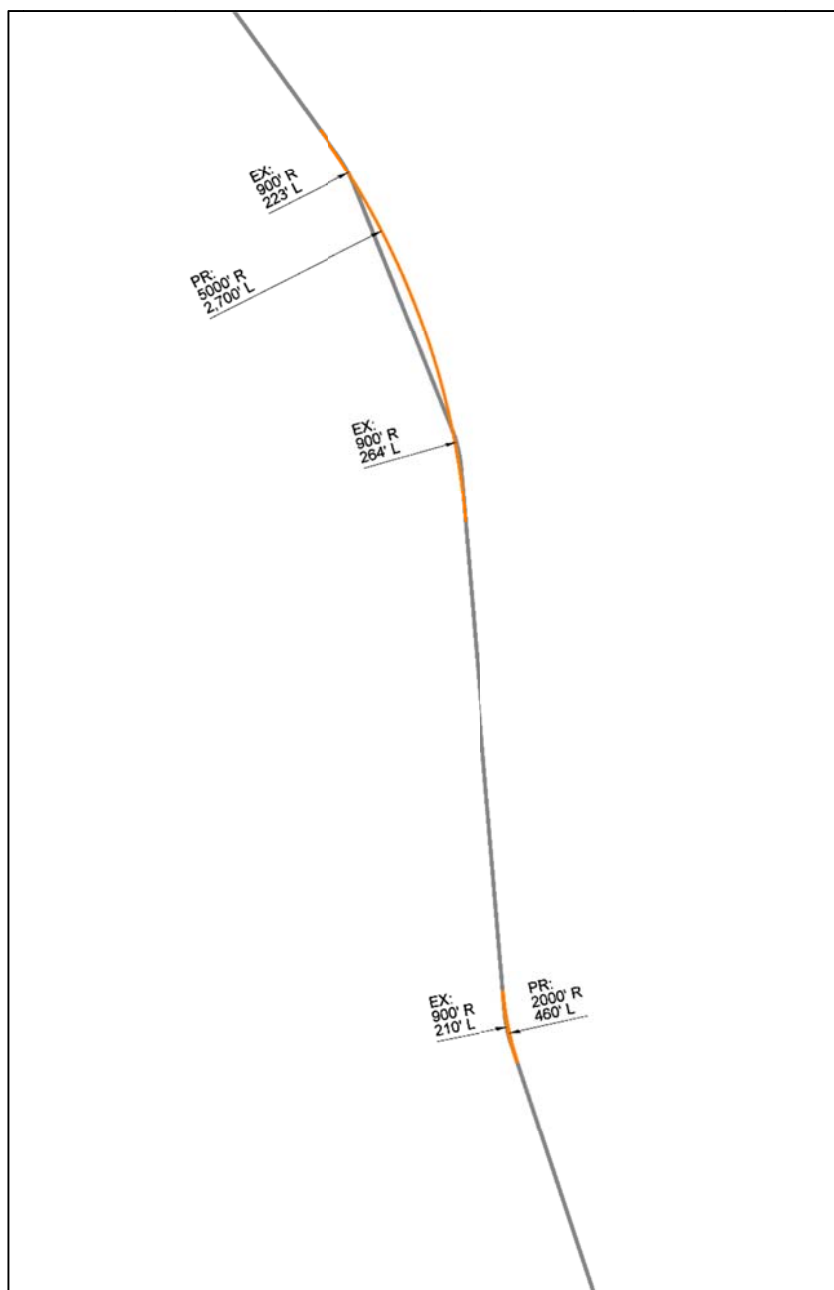

Figure 54. Two horizontal curves with existing and proposed alignments

Table 32. Case Study 3 Traffic Analyses Results

Alternative		Traffic Operational Analysis Results		
		Level of Service	Average Travel Speed (mph)	Percent Time Spent Following (%)
Existing	NB	D	44.2	61.7
	SB	E	43.0	82.3
Proposed	NB	C	46.8	61.7
	SB	E	45.6	82.3

LOS was determined using HCS 2010 Version 6.30

Table 33. Case Study 3 Crash Analyses Results

Alternative	Predicted Crashes per mile per year		
	Total	Fatal and Injury	PDO
Existing	8.1	2.6	5.5
Proposed	3.1	1.0	2.1

Predicted crashes were determined using HSM 1<sup>st</sup> Edition, Chapter 10 Worksheets (uncalibrated model without crash history input)

K = Fatal

A = Incapacitating Injury

B = Non-incapacitating Injury

C = Reported Injury

PDO = Property Damage Only

### Traffic Operational Analysis Results

Table 32 shows a comparison of the traffic operational LOS for these alternatives, based on HCM methods and assumptions. The full reports from the HCS software are attached. In general, the proposed project would provide a slightly higher travel speed (increased by about 2 mph in both directions of travel), and a higher level of service in the northbound direction of travel. The improvements would not impact percent time spent following. In this case, because of the lower speed on the road, LOS is determined primarily by average travel speed, rather than by percent time spent following.

### Traffic Safety Analysis Results

Table 33 shows a comparison of the predicted safety performance (annual crashes) for the section for the design year. The following assumptions were made in the HSM analysis for both the existing and proposed scenarios:

- Zero-percent grade
- No superelevation variance on horizontal curves
- No spiral transitions on horizontal curves
- No roadway lighting
- No automated speed enforcement
- Roadside hazard rating = 2
- 10 access points per mile along the section

Chapter 10 of the Highway Safety Manual, at this time, does not include a CMF for shoulder rumble strips, so the safety benefit these may provide is not accounted for in this analysis; however, the CMF for centerline rumble strips was applicable and did provide safety benefit.

The Intersection Worksheet for HSM Chapter 10 was not used because the section did not include any major intersections.

The safety comparison of the two designs reflects the following:

- Widening the paved shoulder, including centerline rumble strips, and flattening the curves results is predicted to result in a substantial (62 percent) reduction in crash frequency (from 8.1 to 3.1 crashes per mi per year)
- The HSM Chapter 10 worksheets allow the analyst to separate the impact of each of the three improvements if such information were desired.

- A CMF for shoulder rumble strips could be taken from HSM part D or the CMF Clearinghouse to adjust these results from the Chapter 10 worksheets to account for their impact on safety if the analyst chose to do so. This would increase the safety benefits of the proposed project even further.
- Calibration to local conditions and the incorporation of historical crash data into the EB analysis would provide results more specific to this specific location.

## Conclusions

The proposed project will improve the LOS on the northbound direction of travel from LOS D to C, while having no effect on the LOS in the southbound direction of travel, which will remain at LOS E. Thus, the project will have a positive effect on traffic operations, but further consideration of alternatives to improve traffic operations in the northbound direction of travel would be desirable.

The project is predicted to result in a substantial (62 percent) reduction in crash frequency, from 8.1 to 3.1 crashes per mi per year. The predicted reduction in crashes would be even larger if a CMF for shoulder rumble strips were included in the HSM Chapter 10 procedure.

This Case Study shows that existing HCM and HSM procedures are well suited to evaluation of this type of project, since effects of all of the proposed changes are accounted for, with the single exception of the effect of shoulder rumble strips on rural two-lane highways. This indicates that performance-based design is a practical approaches to assessment of reconstruction or 3R projects on rural two-lane highways.

## 7.2.4 Case Study 4

### Background

A bypass is proposed around a small community. This two-lane highway roughly serves as a border between this small community of fewer than 200 people, and a city of nearly 15,000. Projected traffic volumes for design year 2040 are substantially higher than what the current facility can accommodate, so the proposed bypass, which will rebuild the highway along a path to the west of its current alignment and bring it within the city limits, will be a divided four-lane facility. The existing highway alignment will essentially become a local road to serve the homes and farms of this small community. The existing highway will turn off of the proposed new alignment at a stop-controlled intersection on the south side of the bypass. The original road will dead-end just prior to where it would rejoin the proposed new alignment. Figure 55 provides a map of the existing highway overlaid with a drawing of the proposed bypass and other improvements to the surrounding facilities.

The purpose of the proposed project is to provide mobility to through traffic and to reduce traffic (especially truck traffic) through the small community. The existing highway is not described as a high crash corridor.

This case study compares the operational and safety performance of the existing facility with projected volumes for the 2040 design year with the proposed realignment, including both the new highway segments and intersections and the segments and intersections that will remain along the old highway. The analysis runs from intersection EI1/PI1 on the south side of the corridor to EI5/PI5 on the north side of the corridor. Performance of the dead-end segment of the old highway in the proposed condition was not considered. In addition, performance on the side streets is not considered in this case study, even though some realignments and improvements to side streets were included as part of this project.

Figure 56 shows the 2009 volumes for the existing highway alignment and Figure 60 shows the projected 2040 volumes for the proposed project that were used in this evaluation. Figure 57 shows the typical cross-section for the proposed alignment of the new highway.



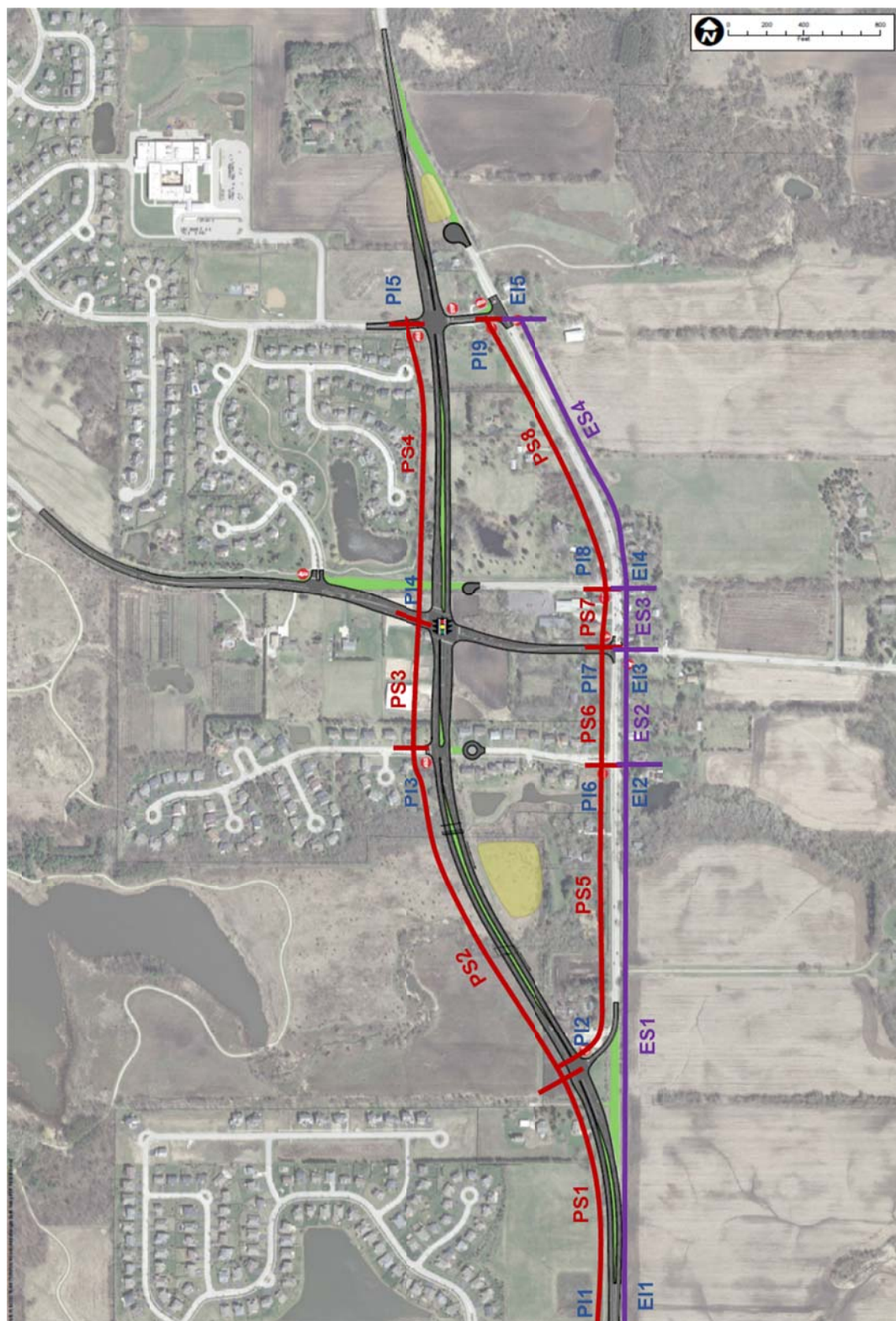

Figure 55. Map of existing conditions overlaid with drawing of proposed highway realignment.

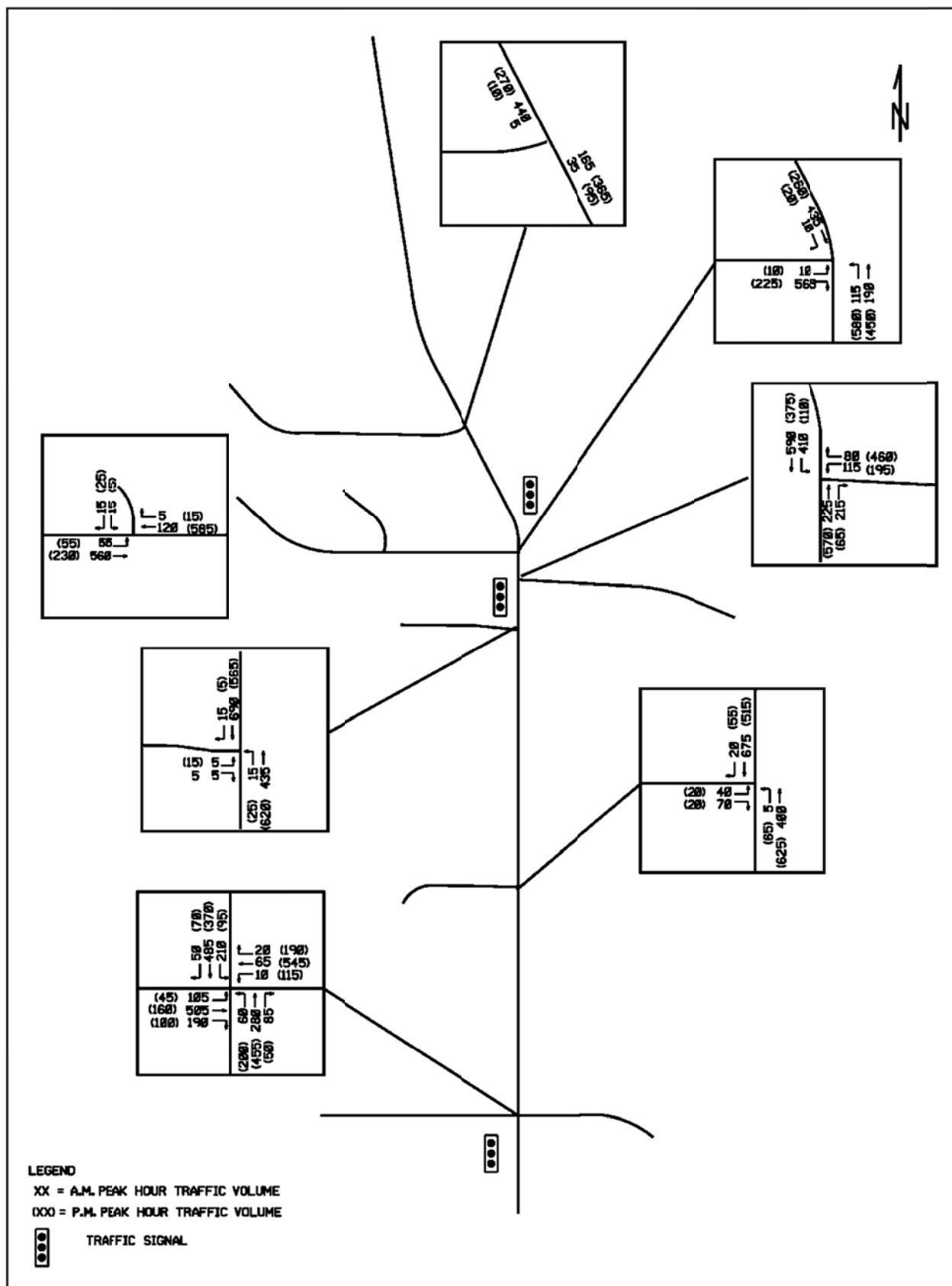

Figure 56. 2009 peak hour volumes and ADT at intersections along existing Highway.

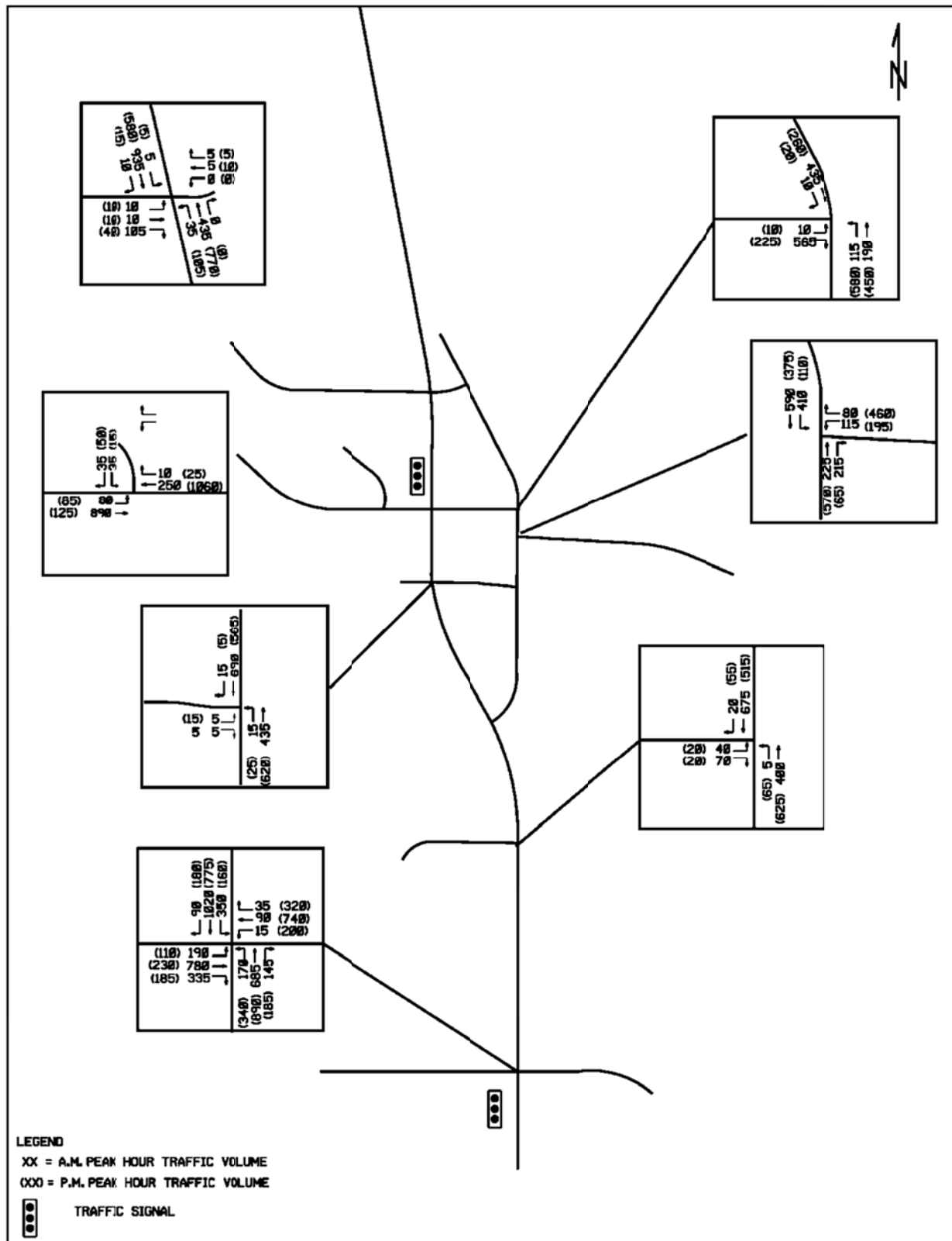

Figure 60. Design year 2040 peak hour turning movement volumes and AADT for intersections along both the proposed highway alignment and the existing alignment.

## Assumptions

Detailed inputs used in the safety and operational analysis came from existing data for the actual project site. Where existing data were not available, reasonable assumptions were made by the analysts. The following assumptions were made:

- Existing and proposed routes were evaluated as an urban/suburban arterial. The proposed “Old Highway” will likely function more as a local road than an arterial, but the anticipated design year volumes are within the range of acceptable volumes for an urban/suburban arterial.
- Traffic growth rate is the same for both the “no build” scenario and the “bypass build” scenario. (Expected volumes along the existing highway alignment for design year 2040 were not provided, so the analysts made this assumption.)
- Conversion of this highway from a two-lane to a four-lane facility extends beyond the north and south borders of the bypass project in design year 2040; however, only the area immediately surrounding the proposed bypass is evaluated in the safety and operational analysis. This assumption was needed for the operational analysis, which required a consistent cross-section in the segment to the south of the bypass area. The safety and operational impacts of conversion to a four-lane highway outside of the bypass area were not evaluated.
- Improvements to side streets were not considered in the analysis; only segments on the new and old alignment were included.
- A tree line exists along much of the existing highway right-of-way line (about 25 to 30 ft from the roadway) making the roadside fixed object density fairly high; however, trees are proposed along the new facility as well and they are closer (see proposed typical cross-section for bypass in Figure 57). An assumption was made that the roadside fixed object density along the new facility would be slightly lower than existing.
- Access points along existing highway in design year 2040 are the same as existing. While there is space for development along the east side of the corridor, the analysts chose not to speculate on what accesses may be necessary for potential future growth.
- Access points along existing highway in design year 2040 are the same regardless of whether bypass is built.
- Access points along the new highway bypass in design year 2040 will serve existing adjacent properties with no access to other routes only; no access points to serve possible future development were considered.
- New bypass segments and intersections will be lighted.
- Peak hour factor is 0.95.
- Percent heavy vehicles is 2 percent.
- Terrain is level.
- Pedestrian and bicycle activity is insignificant, thus not considered in the operational analysis.

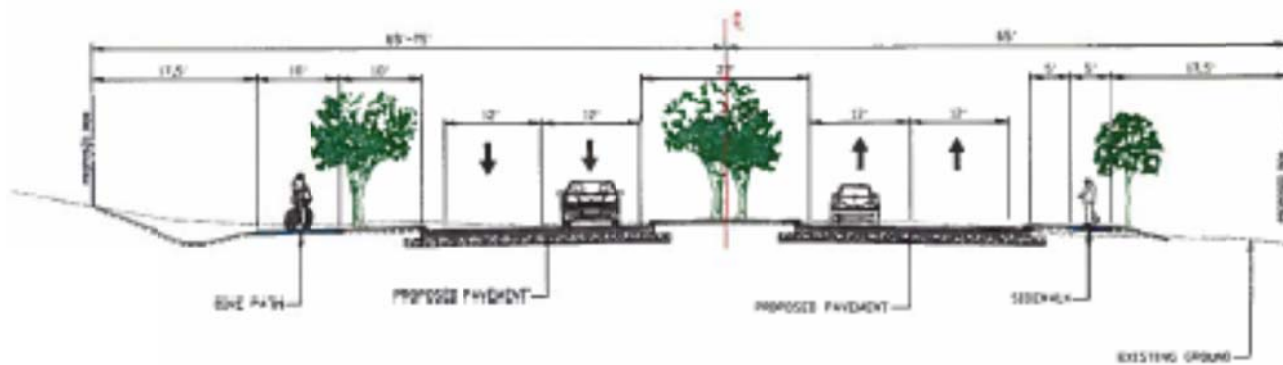

Figure 57. Proposed typical cross section for proposed alignment of highway (bypass).

## Traffic Safety Analysis

### Methodology

The traffic safety prediction methodology for urban and suburban arterials presented in HSM Chapter 12 was used for the safety analysis of all roadway segments and intersections within the project boundaries considered in this case study. The calculations were performed using the associated Excel spreadsheets that were developed to implement that procedure (which are available on the HSM website).

Safety estimates are based on the safety performance functions presented in HSM Chapter 12. A calibration factor of 1.0 was used. Crash history at this site was not considered in the analysis, so all estimates are based on the safety performance of similar sites used to develop the SPFs in the HSM.

### Results

The expected safety performance of the segments and intersections along the existing alignment of the highway in the design year 2040 are shown in Table 34. Results are presented by crash severity level (total, fatal and injury, and property damage only) and crash type (single-vehicle, multi-vehicle non-driveway, and driveway) for individual segments and intersections. Total predicted annual crashes by severity level for all segments and intersections combined are shown in the final row of the table. The results of the safety analysis show that if left unchanged, the highway through the analysis section is predicted to experience 33 crashes per year in 2040, including 10 fatal and injury crashes.

Table 35 presents similar information for the proposed project, including the new realignment and the remaining “Old highway” segments and intersections. In the proposed conditions, Old and New Highway segments and intersections combined are predicted to experience 22 crashes per year in 2040, including 7 fatal and injury crashes. This represents 33 percent reduction in crashes compared to the expected condition if no project were constructed.

Table 34. Predicted crashes by severity level for segments and intersections along the existing highway alignment in design year 2040.

Predicted Crashes by Severity Level for Existing Conditions in Design Year 2040			
Collision type / Site type	Predicted average crash frequency (crashes/year)		
	N <sub>predicted</sub> (TOTAL)	N <sub>predicted</sub> (FI)	N <sub>predicted</sub> (PDO)
<b>ROADWAY SEGMENTS</b>			
Multiple-vehicle nondriveway			
Segment 1	6.388	1.831	4.557
Segment 2	1.346	0.386	0.960
Segment 3	0.954	0.272	0.682
Segment 4	0.567	0.164	0.403
Single-vehicle			
Segment 1	0.966	0.148	0.818
Segment 2	0.204	0.031	0.172
Segment 3	0.118	0.017	0.101
Segment 4	0.143	0.026	0.117
Multiple-vehicle driveway-related			
Segment 1	0.433	0.140	0.293
Segment 2	0.182	0.059	0.123
Segment 3	0.678	0.219	0.459
Segment 4	0.156	0.050	0.106
<b>INTERSECTIONS</b>			
Multiple-vehicle			
Intersection 1	2.326	0.786	1.540
Intersection 2	1.084	0.460	0.624
Intersection 3	7.100	2.127	4.973
Intersection 4	7.779	2.257	5.523
Intersection 5	1.211	0.431	0.780
Single-vehicle			
Intersection 1	0.175	0.052	0.123
Intersection 2	0.071	0.022	0.049
Intersection 3	0.412	0.123	0.289
Intersection 4	0.475	0.148	0.327
Intersection 5	0.128	0.039	0.089
COMBINED (sum of column)	32.9	9.8	23.1

Table 35. Predicted crashes by severity level for segments and intersections along the existing US 4th proposed highway alignment (bypass) and "Old Highway" in design year 2040.

Predicted Crashes by Severity Level for Proposed Conditions in Design Year 2040			
Collision type / Site type	Predicted average crash frequency (crashes/year)		
	N <sub>predicted</sub> (TOTAL)	N <sub>predicted</sub> (FI)	N <sub>predicted</sub> (PDO)
<b>ROADWAY SEGMENTS</b>			
Multiple-vehicle nondriveway			
Segment 1	1.762	0.476	1.286
Segment 2	1.834	0.501	1.333
Segment 3	0.672	0.184	0.488
Segment 4	1.082	0.303	0.779
Segment 5	0.156	0.047	0.110
Segment 6	0.058	0.017	0.040
Segment 7	0.007	0.002	0.005

Segment 8	0.031	0.009	0.022
Single-vehicle			
Segment 1	0.239	0.044	0.195
Segment 2	0.287	0.052	0.235
Segment 3	0.105	0.019	0.086
Segment 4	0.226	0.039	0.187
Segment 5	0.193	0.054	0.139
Segment 6	0.071	0.020	0.051
Segment 7	0.022	0.008	0.014
Segment 8	0.107	0.039	0.068
Multiple-vehicle driveway-related			
Segment 1	0.048	0.014	0.035
Segment 2	0.036	0.010	0.026
Segment 3	0.160	0.045	0.114
Segment 4	0.010	0.003	0.007
Segment 5	0.054	0.017	0.036
Segment 6	0.028	0.009	0.019
Segment 7	0.035	0.011	0.024
Segment 8	0.015	0.005	0.010
INTERSECTIONS			
Multiple-vehicle			
Intersection 1	2.116	0.715	1.401
Intersection 2	2.909	0.880	2.029
Intersection 3	0.866	0.369	0.497
Intersection 4	4.638	1.568	3.070
Intersection 5	1.375	0.548	0.827
Intersection 6	0.058	0.032	0.026
Intersection 7	1.526	0.599	0.927
Intersection 8	0.025	0.015	0.010
Single-vehicle			
Intersection 1	0.159	0.047	0.112
Intersection 2	0.236	0.068	0.168
Intersection 3	0.064	0.020	0.044
Intersection 4	0.272	0.067	0.205
Intersection 5	0.135	0.041	0.094
Intersection 6	0.018	0.007	0.012
Intersection 7	0.167	0.046	0.120
Intersection 8	0.017	0.007	0.010
COMBINED (sum of column)	21.8	7.0	14.9

### Limitations

- Intersection of Old Highway and Independence Boulevard in the proposed condition (PI9 in the figure) is an all-way stop. This intersection type is not currently included in the HSM; therefore, no safety analysis was performed at this intersection. However, traffic volumes are expected to be very low at this intersection, so it is anticipated that there would be very few crashes here.
- It is unclear if “Old Highway” will function as an urban arterial in 2040 as it currently serves very few properties and will no longer be a through street; however, this methodology was the best available option.
- Inclusion of pedestrian and bike facilities are not accounted for in this analysis. The HSM provides procedures for estimating bike and pedestrian crashes at signalized intersections, but those procedures were not used

here. The HSM segment procedure for urban and suburban arterials does not provided a methodology for assessing the safety impact of pedestrian and bike facilities along the roadway.

## **Traffic Operational Analysis**

### **Methodology**

The traffic operational analysis for this project was conducted with the urban street procedures of the HCM2010. Procedures from HCM Chapters 16 (Urban Street Facilities) and 17 (Urban Street Segments) were used in conjunction with the Streets, two-way stop-controlled intersection (TWSC), and all-way stop-controlled intersection (AWSC) modules of HCS2010 to develop LOS assessments for the existing highway alignment and the proposed alignments of the new and old highway in design year 2040 during the AM and PM peak hours. The Streets module does not allow the analysis of street segments with boundaries at locations other than signalized intersections, so procedures from HCM Chapters 16 and 17 were necessarily used in order to combine the control delay outputs from the HCS modules and assess LOS scores for roadway segments and for the facility as a whole.

### **Existing Highway Alignment in Design Year 2040**

This urban street facility is comprised of Segments ES1 through ES4. As mentioned above, this facility could not be completely analyzed in the Streets module of the HCS due to uncontrolled segment boundaries. As defined in the HCM, an urban street facility is divided into segments by intersections that impose a stop or yield condition on through vehicles, although theoretically a roadway can be divided at an uncontrolled location. So, this urban street facility was logically broken down into four segments: ES1; ES2; ES3; and ES4. While ES1 and ES2 could be combined into one segment, the speed limit changes between these two segments, so they were kept separate in the analysis. Segment ES3 is bound by two signalized intersections, so ideally this segment can be analyzed using the HCS Streets module. These two signalized intersections (EI3 and EI4) are separated by just over 300 ft. The HCM suggests using the ramp terminal procedures to analyze this situation due to a high probability of queue spillback into the upstream signal, however the HCS version 6.3 does not have a functioning interchange module. Segment ES3 was analyzed using the Streets module instead. Despite optimal signal timing strategies, several intersection approaches in both AM and PM peak periods including mainline approaches have V/C ratios exceeding 1.0. The Urban Street Facilities procedure indicates that any segment whose boundary has a V/C greater than 1.0 is an automatic LOS F for the urban street facility as a whole. HCM Chapter 16 and 17 procedures were used to tie together the HCS outputs into LOS scores for both AM and PM peak periods.

### **Proposed Alignment (Bypass) in Design Year 2040**

This urban street facility is comprised of Segments PS1 through PS4. Again, this facility could not be completely analyzed in the Streets module of the HCS. This facility was divided into two segments: PS1-PS3; and PS4. The Streets module was used to optimize the PI4 signal and generate control delays for both directions. It was assumed that the two-way stop-controlled intersections that bounded both segments (PI1 and PI5) will not impose any control delay on the uncontrolled through movements. The TWSC module was used to verify this assumption. HCM Chapter 16 and 17 procedures were used to tie together the HCS outputs into LOS scores for both AM and PM peak periods.

### **Old Highway Alignment in Design Year 2040 (with Highway on Bypass)**

This urban street facility is comprised of Segments PS5 through PS8. This facility was divided into two urban street segments: PS5-PS6; and PS7-PS8. Both segments are bounded by stop control. TWSC and AWSC modules were used to compute control delays for the through movements at the segment boundaries, and HCM Chapter 16 and 17 procedures were used to tie together the HCS outputs into LOS scores for both AM and PM peak periods.



**Results**

Table 37 summarizes the results of the traffic operational analysis for year 2040 conditions. The table shows that the existing highway alignment, if not improved, would operate at LOS B in the northbound direction of travel during the AM perk period, but would operate at LOS F in the southbound direction during the AM peak period and at LOS F in both directions of travel during the PM peak period. This clearly documents the need for the project.

The table indicates that the proposed new highway alignment (bypass) would operate at LOS B or C for both directions of travel during both peak periods in 2040. This indicates that the new alignment will provide much improved traffic service than the existing facility in 2040.

The table indicates that old highway alignment, carrying reduced traffic volumes, will operate at LOS B or C in both directions of travel during the PM peak period. However, the old highway alignment will operate at LOS D in the northbound direction and LOS F in the SB direction during 2040. These poor LOS levels occur because the left-turns at existing intersection labeled PI7 in Figure 1 have substantial delay. This intersection is currently signalized, but would operate as a two-way stop-controlled intersection in the proposed future condition. The SB left-turn movements at this intersection, while very low in volume, create substantial control delay for the SB approach. Some change in traffic control at this intersection may be needed.

Table 36. LOS Assessment for Roadway Segments in the Existing and Proposed Alternatives for the Design Year 2040

Existing Alignment in Design Year 2040				
Period	AM Peak 2040		PM Peak 2040	
Direction	NB	SB	NB	SB
Travel Speed as a Percentage of Base Free-Flow Speed (%)	76%	20%	15%	24%
LOS	B	F	F	F

Proposed Alignment (Bypass) in Design Year 2040				
Period	AM Peak 2040		PM Peak 2040	
Direction	NB	SB	NB	SB
Travel Speed as a Percentage of Base Free-Flow Speed (%)	67%	62%	71%	66%
LOS	C	C	B	C

Old Highway Alignment in Design Year 2040				
Period	AM Peak 2040		PM Peak 2040	
Direction	NB	SB	NB	SB
Travel Speed as a Percentage of Base Free-Flow Speed (%)	50%	25%	76%	52%
LOS	D	F	B	C

## Conclusions

The proposed project is expected to reduce crashes by 33 percent under design year conditions. The new alignment (bypass) operates effectively at LOS B or C in the design year, while the existing alignment, if not improved, would operate at LOS F under most peak conditions. The old alignment, even with much reduced traffic volumes, operates poorly as an urban arterial segment due to substantial control delay at one intersection. Further investigation of one intersection on the old alignment is recommended.

Case Study D shows that the available traffic operational and safety analysis tools are very appropriate to address this type of project, and a performance-based design approach would be very appropriate.



### 7.2.5 Case Study 5

Current design policy per AASHTO and FHWA places strict limitations on lane width for freeways, with no allowance under policy for lane widths less than 12 feet. Of course, there are sufficient examples of freeway projects in which lesser lane widths have been constructed or reconstructed such that the relative safety performance of lane widths less than 12 feet can be assessed.

The design process for high volume urban freeways should allow for the evaluation of alternative cross section designs that include lane widths of less than 12 feet. There are quantifiable benefits associated with narrower lanes that include the ability to provide additional lanes within limited space, and the cost to reconstruct what are the most costly facilities in the highway system.

The ISATe HSM and 2010 HCM procedures reveal the relative value of different freeway cross sections using the same total width (lanes and shoulders) but allocating the dimensions such that one additional lane of travel is provided.

Table 38 shows a comparison of the predicted safety performance (annual crashes) for a 1-mile tangent freeway segment with 150,000 vehicles per day (vpd) for two design alternatives that use the same total cross section dimension. A 4-lane section with 12-foot lanes and full shoulders left and right produce more crashes, although less severe crashes, than a 5-lane section with 11-foot lanes, full right shoulder but narrower left shoulder.

Table 38 also shows a comparison of the capacity or throughput for these designs, based on HCM methods and assumptions. The traffic-carrying capability of the five-lane segment is substantially greater than that of the four-lane segment, even with narrower lanes and left shoulder.

ADT = 150,000 vpd	Length = 1 mile
Directional Distribution = 60/40	Trucks = 8%
K = 10%      DHV = 9000 vph	PHF = .94

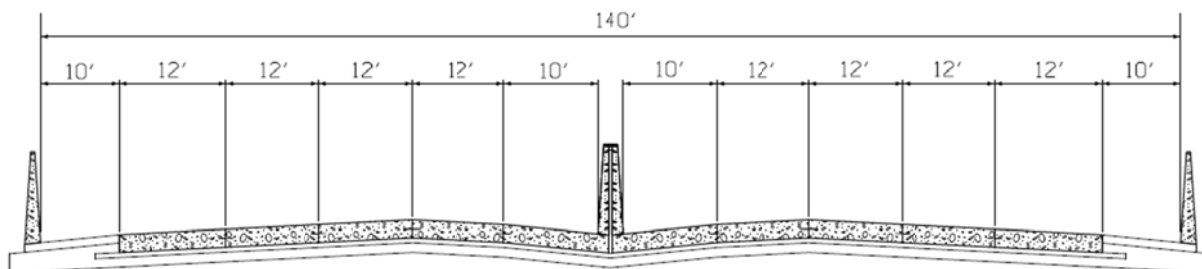

Figure 58. Case Study 5, Alternative 1 Typical Section

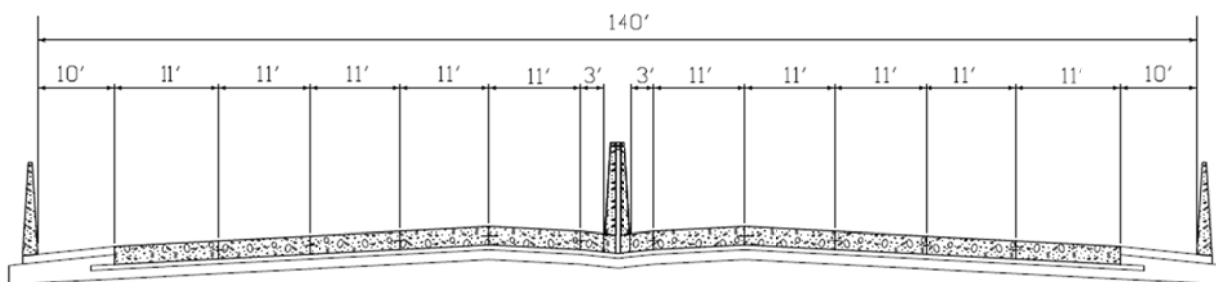

Figure 59. Case Study 5, Alternative 2 Typical Section

Table 37. Case Study 5, Traffic Analyses Results

Alternative	Capacity Analysis Results		
	Level of Service	Density (pc/mi/ln)	Speed (mph)
1	F	61.3	43.7
2	E	35.5	60.5

LOS was determined using HCS 2010 Freeways Version 6.60

Table 39. Case Study 5, Crash Analyses Results

Alternative	Predicted Crashes per mile per year					
	Total	K	A	B	C	PDO
1	46.8	0.2	0.6	3.2	9.7	33.2
2	40.1	0.3	0.6	3.5	8.1	27.7

Predicted crashes were determined using ISATe (Build 6.10) (uncalibrated model without crash data input)

K = Fatal

A = Incapacitating Injury

B = Non-incapacitating Injury

C = Reported Injury

PDO = Property Damage Only

The substantive safety comparison of the two designs may appear counterintuitive. It reflects the following:

- Safety performance of higher volume freeways reflects multivehicle crashes, typically rear-end, which are little affected by marginal differences in lane width
- Crash frequency increases with density and volume to capacity; both of which are a function of the throughput capacity, which is defined by the number of lanes. The benefits of providing one more lane of traffic, even with lesser width dimensions and reduced left shoulder width, exceed the marginal adverse effects of the narrower lane and left shoulder widths.

The above analysis, while hypothetical, demonstrates both the value of considering more flexible lane and shoulder width design values, as well as the concept of optimizing a design for a given available total width dimension.

## 7.2.6 Case Study 6

A state DOT is undertaking the development of a long range plan for reconstruction of a suburban freeway system, including its interchanges. The current freeway is six lanes (three in each direction) with full shoulders on each side and a 40-ft median.

One interchange within the corridor between the freeway and a County Trunk Highway (CTH) will require reconstruction. The CTH is a two-lane road. Development along it has led to the County's need to widen the CTH to a four lane divided arterial. The existing diamond interchange, including a crossroad bridge over the freeway and ramp terminal intersections, have insufficient capacity to accommodate expected future traffic demands. In addition to the need to reconstruct the CTH interchange, there is an additional road structure over the freeway about ¼ mile to the east of the CTH bridge. This structure carries local road traffic. It is at a 45 degree skew over the freeway. Although there are no traffic operational or safety performance issues associated with this bridge, its regular condition reports indicate a near term need for substantial structural repair investments. (There are no recent traffic counts available for the bridge, but County staff estimate it carries no more than a few hundred vehicles a day.) Although the bridge carries local (County) traffic, the bridge itself is owned by and the

responsibility of the DOT. The DOT has indicated that it may need to post or even close the bridge to traffic should further deterioration occur.



Figure 60. Case Study 6 Location Map

Source: Google earth

Figure 64 shows CTH interchange and the local bridge. A summary of land use conditions is as follows: To the north, commercial and office development zoning exists, with some development already occurring in the northeast quadrant of the interchange. The northwest quadrant, and lands further north abutting the CTH are planned for extensive development. The southwest quadrant includes a creek and wetlands. Some developable property exists, but local officials would prefer it remain open. Moreover, access to the southwest quadrant would be difficult given proximity of driveways to the CTH interchange. In the southeast quadrant, land use is limited to single family residences with low density.

A design team has been assigned the challenge of developing a geometric design solution for the CTH interchange with the freeway, and to address the issue of the local road bridge. Traffic demand studies and agency policies regarding traffic operations have brought the following conclusions:

- The freeway should be widened to eight basic lanes (four each direction).
- At least two configurations for the CTH/freeway interchange appear reasonable. Both of these would require widening of the CTH bridge crossing over the freeway from two lanes to either six or eight lanes, depending on the configuration selected.
- Exiting demand from the east is such that a two-lane exit, with auxiliary lanes from westbound, are considered necessary. Similarly, an auxiliary lane for entering traffic eastbound is needed.
- Points 1) and 3) above mean that the existing local bridge over the freeway (in poor structural condition) cannot remain in place, as the available openings between the abutments are insufficient to accommodate

the additional two lanes plus shoulders, even considering the potential use of design exceptions for lane and shoulder width along the freeway.

- Given 4) above, the design team concludes that the local road bridge must be replaced, i.e., that structural repairs make no sense given it would not fit within the context of the plans for the freeway and new CTH interchange.

The design ‘problems’ or ‘needs’ have thus been defined as selecting an interchange configuration; and designing a new local road bridge to replace the one in poor condition. An implementation challenge is the sequencing of the improvements. The new CTH interchange may take four years to complete considering all environmental and public consultation processes. It seems evident that the replacement of the local road bridge will need to be included in the CTH interchange project.

### Engaging Stakeholders in Project Development

Internal project stakeholders include the traffic operations engineer, geometric design engineer, travel demand forecasters, state bridge engineer, environmental coordinator, and public involvement specialists. External agency stakeholders include the County Engineer, County land use and zoning staff, and local town planning staff. All are supportive of and engaging in developing solutions to the new interchange and local bridge replacement effort.

External stakeholders include existing business owners to the north, developers, and homeowners who live south of the freeway.

An important concern is the potential for detours or traffic shifts during construction. Dialogue with stakeholders reveals interesting insights that shape the project.

- Both County staff and local developers agree on the importance of widening the CTH in a manner that preserves traffic flow during construction, so access to their properties is not adversely affected. During such discussions, project staff learn that the businesses rely solely on the CTH for access; and that they do not consider the local road as being important to serving their properties.
- Homeowners living south of the freeway fear the influx of traffic from development as it occurs; and especially during reconstruction of the CTH interchange. They suspect that ‘spillover’ or detouring traffic from the north will emerge on the local road. They express concerns over this expected problem. Interestingly, few of them use the local road.
- Engagement with the local emergency service providers reveals that they do rely on the local road for access to the homeowners (e.g., the fire station serving them is north of the project area along the CTH). However, project staff learn that the reason the providers use the local road is that the CTH is often congested. They would prefer to use the CTH, and stated an intent to use it once it is widened and the congestion eliminated.

When all of the above information is processed by the project team, they come to a conclusion that was not apparent at all at the project outset. They are responsible for a local road bridge in a condition of disrepair, which conflicts with the needs of the freeway passing beneath it, but which few use and none consider essential.

The DOT project manager suggests that perhaps they have been mischaracterizing the problem all along. The local road bridge should not be referred to as ‘in need of replacement,’ but rather as being in a state of disrepair. With this broader problem definition, the following solutions may be considered:

- Repair the bridge now to buy time while the new CTH interchange is being reconstructed; then replace it sometime later, removing the cost of this replacement from the CTH interchange project and providing more flexibility in funding the overall corridor work.
- Replace the bridge now as originally envisioned
- Remove the bridge and do not replace it.

Option 3 is fully discussed with all stakeholders. The DOT project team confirms that no one considers it essential, no one would miss it; and indeed the local homeowners would be delighted if the bridge is removed as this would preclude the possibility of any spillover traffic.

Plans for widening the CTH cross section and interchange had to maintain traffic along the CTH, and hence in no way relied on the use of the local road crossing.

### **Conclusion**

The design solution decision was thus option 3. Minor repairs were made to enable a few more years of service (primarily to address emergency service provider needs during CTH construction), with the agreement of all that once the CTH interchange was completed, the DOT would remove the local road bridge forever.

This solution, endorsed by all, saved the DOT over \$2 million in initial cost, and additional perpetual maintenance costs associated with a bridge that in fact no one needed or wanted.





# 8 Research and knowledge needs to fully implement the revised process

## 8.1 AASHTO Curve model

The current AASHTO model for design of horizontal curves does not produce cost-effective solutions across the range of project types and contexts. As horizontal alignment is among the most influential elements of road design, a revisiting of the AASHTO curve model with potential for developing a more robust and science-based approach is a high research priority.

The following are research areas and questions that should be addressed:

- Is a comfort based model the appropriate one for all or even any set of conditions? What other approaches or models may apply?
- What might a design model based on crash risk factors associated with horizontal curves look like?
- How should risk as measured by traffic volume be included in horizontal curve design?
- Under which conditions should heavy trucks or vehicles other than passenger cars be the basis for curve design?
- To what extent should the cost of constructing or reconstructing a horizontal curve be part of the design model or approach?
- What interrelationships among vertical geometry, cross section and roadside characteristics should be incorporated in a curve design model?

A straw man approach illustrating these issues was noted earlier in this report to demonstrate a potential new overall approach to curve design. Appendix C contains a paper study of the relative risk of crashes and cost effectiveness analysis for two-lane rural highway curvature, based on the AASHTO Highway Safety Manual models.

This research area warrants a substantial multi-year study aimed at producing a revised, unified, context sensitive approach to horizontal curve design for the 2025 edition of the AASHTO Green Book.

## 8.2 AASHTO SSD Model

Sight distance is the length of roadway ahead that is visible to the driver. This distance at a given speed determines the amount of time available for the driver to react to what is seen. The AASHTO stopping sight distance model consists of two components, perception/reaction distance and breaking distance. The perception / reaction distance is the travel distance at the design speed for the reaction time taken as 2.5 seconds. Stopping sight distance is to be provided at all locations along any road.

The Stopping sight distance model is applied to all roadways regardless of the context. The distance varies based on the speed, but the perception / reaction time does not change based on context.

The decision sight distance for a stopping maneuver uses the same model but varies the perception / reaction time based on the context. In urban areas where there is more distraction the time is longer. This component varies from 3 seconds and 9.1 seconds for rural and urban roads.

AASHTO should revisit the subject of SSD and sight distance controls in general for the urban environment. The research should focus on:

- Risk-based approaches incorporating traffic volume, road type and likely presence of conflicts
- Relationship of available sight distance to relevant crash types and frequency
- Applicability of SSD to design of urban streets vs. an alternative approach based on typical crossing conflicts

## 8.3 O&M Understanding related to Geometric design elements

For most agencies, the typical project development process takes into consideration the capital costs of a project. The cost to maintain the facility is not usually a significant consideration. In a few cases, the feasibility of future maintenance may be considered, but the cost of that future maintenance is typically not. It is important to consider future maintenance costs & activities during the planning/design stage of any significant infrastructure investment, including a highway project, as decisions made early in the lifecycle can have a material impact on future maintenance costs.

### Further research and study

Areas that would benefit from further research and study include:

- Costs and benefits of critical design options to establish dimensional criteria and guidance, including examples.
- Statistical analysis of maintenance personnel incidents and development of substantive crash prediction methods to guide the geometric design of alternatives that affect work zone safety, enforcement, incident management options.
- Better understanding of the short and long-term risks concerning the operation and maintenance of facilities that use ITS technology.

## 8.4 Challenges with new process

The implementation of revised geometric design processes face numerous challenges as seen in the experiences associated with changes that accompanied Load Resistance Factor Design (LRFD) for bridge design, Context Sensitive Solutions (CSS), and the American Association of State Highway and Transportation Officials' (AASHTO) Highway Safety Manual (HSM). The challenges that accompanied Load and Resistance Factor (LRFD) implementation offer constructive insights considering this transition also centered on a new design methodology or process consistent with the focus of this NCHRP research. Ultimately, the states' transition to LRFD took more than a decade despite encouragement by the Federal Highway Administration (FHWA) and AASHTO. While there are numerous reasons for the extended transition, the first is found in the process to prepare the new manuals, which involved AASHTO leading their development, review, and approval process. Each state subsequently underwent a similar review in order to update its manuals, guidelines and procedures. Although this sort of development process takes time, it is acknowledged that this was not the only reason that accounted for the extended transition.

In addition to the development of the new LRFD manuals, the transition was drawn out due to institutional inertia (that is, agency or personal resistance to change) focused around a fundamental disagreement over the need to change ("the original way is working fine"). It has been observed that individual resistance was aggravated because the new process at times resulted in differing designs. Additional issues centered around the need for access to additional training and software. Training was required for junior and senior staff so that they could become familiar with and capable of applying the new process. Universities also needed to redevelop curriculum around the new process. The initial lack of software using the new processes also delayed the transition to LRFD.

Without software, the design and review process would have been lengthy and costly to complete, especially for complex designs. Therefore, the availability of software was important to embracing the new LRFD approach. (1)

Similar challenges were seen when the CSS process and the HSM were introduced into the industry. Likewise, challenges are expected to occur when implementing changes to the geometric design process. This chapter reviews several of the design processes discussed in the other chapters of this report, summarizes the key challenges expected [restraining forces], and presents several recommended practices [driving forces] to help mitigate these challenges.

### 8.4.1 Summary of Potential Design Processes

*Alternative Design Process Concepts*, presented the following ten alternative design process concepts.

- The *complete streets* concept focuses on creating roadways and related infrastructure that provide safe travel for all users.
- The concept of *context sensitive design*, better known as *context sensitive solutions*, places priority on assuring that highway projects fit the context of the area through which they pass, puts project needs as well as the values of the highway agency and community on a level playing field, and considers all trade-offs in decision making.
- The concept of *performance-based design* incorporates a design process that considers explicit consideration of performance measures, typically operational and safety performance measures.
- The concept of *practical design* focuses on addressing only those improvements that are needed and eliminating those improvements that are not absolutely essential, thereby reducing the overall cost of a project.
- The *design matrix approach* includes three levels of design for highway projects: basic, modified, and full design levels.
- The *safe systems approach* takes a holistic approach in that the responsibility for road safety is shared between all facets of the transportation system (that is, roadway infrastructure, roadway users, and vehicles).
- The concept of *travel time reliability* focuses on designing a roadway in such a way that maximizes the travel time reliability of the roadway.
- The concept of *value engineering* is a systematic process of project review and analysis by a multi-disciplinary team to provide recommendations for improving the value and quality of the project.
- The concept of *Designing for Resurfacing, Restoration and Rehabilitation Projects* includes a set of geometric design criteria for 3R projects that are less restrictive than the geometric design criteria in use for new construction and reconstruction.
- The concept of *Designing for Very Low-Volume Local Roads ( $\leq 400$  ADT)* recognizes that very low-volume local roads represent a different design environment than higher-volume roads.

Each process has its own focus, with the developers observing an existing issue and subsequently developing a revised process to address their problem. Nonetheless, each process likely had its own challenges when responsible agencies were developing and implementing these approaches, or when other agencies sought to adopt the design concept. Acceptance and promotion of the final revised design process should identify and address challenges in the establishment and introduction of a revised process. The following sections provide an overview of likely challenges and barriers for any process change. Depending on the final process recommendation, there may be unique challenges and barriers that will be further identified and addressed at that time.

### 8.4.2 Challenges to Implementing a Revised Geometric Design Process

Challenges and barriers are expected for any revised process an industry or agency may undertake. Restraining forces may be concentrated within a small group of individuals or could be concerns shared by a large portion of

the target population. Specific to a revised geometric design process, challenges have been identified and categorized in the following four areas:

- Organizational and Institutional;
- Risk Management;
- Scalability for Owner, Roadway and Project Size; and
- Professional.

A summary of the key challenges and barriers expected within each category is provided in the following sections.

### 8.4.3 Organizational and Institutional

The most significant challenges and barriers to a revised process will likely occur in the area of organizational or institutional resistance. Reasons will span a wide range of viewpoints, but many will have a foundation in the cost of changing the way business is done. Therefore, it is important these concerns be identified and understood before establishing a plan to implement a revised design process.

- At this stage, the revised design process is envisioned to use new and evolving processes that better quantify the safety performance of design alternatives, such as the HSM predictive models. As with any new model, there are potential data and data systems needs that an agency will be unable to meet (for example, a road and intersection inventory of elements used by models). Agencies may need to invest significant resources in developing and maintaining such data and systems. There is also the issue of maintaining this information on local and low-volume roads, where there is already limited information available. Initially, agencies may need to prioritize and identify which data elements are the most crucial to their design process and focus resources in these areas.
- Agencies need staff experienced in performing operational and safety analyses that are envisioned to support a revised geometric design process. Having these skill sets participate in the project development process will be important to a successful design. Agencies will need to invest in training a complement of staff that can support the project development. For state DOTs, this might include having staff that can support local agency projects.
- Design engineers may need to learn and accept new design criteria and models for their use. This could range from updating existing criteria based on outdated models, or potentially new analyses or models as well as processes for selecting criteria for projects based on the project's context and purpose.
- Institutional inertia, or an agency's resistance to the change, can stem from multiple misperceptions about the revised processes. A common misperception would be that the revised approach increases the time and cost of the design process without any evident benefit or gain to the agency. There are also learned biases regarding design standards and design approaches that still exist (that is, the nominal safety mindset which is a design is safe when all design criteria are met) despite that CSS, Complete Streets, and practical design have been in use for several years.
- The transition process will also be a challenge for most agencies. Needs regarding training, documentation, and process quality control will have to be addressed before the first project can be developed using the revised process. There will then be a point at which an agency must commit to using the revised process on all new projects, trusting that the implementation plan has been successful.
- Most transportation agencies have different sections or bureaus that deal with the different functions. The design section is often separated from the traffic section that focuses on the operations and the planning section that develops the concept of the improvement being designed. The improved process breaks down these silos and provides for better communication between the various functions.

### 8.4.4 Risk Management

Agencies must be aware of risk management, starting in project development and through construction, operation and maintenance of their system. A revised geometric design process should not only allow design engineers to understand the potential implications of their decisions, but provide a process to document and defend decision making so not to put the state in a situation of unnecessary tort risk.

- It was earlier noted that the revised processes may create additional need for data, analysis or software. Especially early in the transition when agencies might have limited data, experience or access to software, the revised process requires a framework for allowing design engineers to make decisions that can be defended in a tort case.
- A revised geometric design process may result in new or different documentation to support the defense of an agency. Agencies should coordinate with legal staff to help determine which decisions need documentation and the type of documentation to maintain.
- Through the decades, there have been many improvements to vehicles and their performance. While some of the geometric models are based on driver comfort, it might be possible to update the models taking into consideration the performance of modern vehicles. However, this will need to be weighed against the existing fleet's characteristics, including the antique and classic cars still on the road. Therefore, a potential risk management issue is that the process should continue to design to the lowest common denominator or take advantage of the advances in automobile performance.
- Prior to the recent efforts and research to expand the scientific knowledge on geometric elements and safety performance; operational elements had been central to the design itself. If this were to remain the same with the recommended revised design process, then a potential liability issue could remain since the process doesn't make use of the latest knowledge. Therefore, it is key for the future of risk management that the revised design process make full use of the expanding knowledge in highway and traffic safety.

### 8.4.5 Scalability for Owner, Roadway and Project Size

Changes to develop a data-driven process that relies on operational and safety analysis to inform the decision making process could be a challenge for local agencies. Scaling the process to not only fit the context of the road environment, but also to the agency responsible for implementation, is important.

- Cities and counties with relatively smaller programs in comparison to the state DOT may initially struggle with having the technical expertise and software. At the outset of transitioning local agencies to the revised process, the state DOT may need to support training, provide access to any developed software and assist in project development for pilot projects.
- Rural counties, townships and small towns that predominantly operate lower-volume systems may have challenges performing operational and safety analyses that are part of the revised geometric design process due to either a lack of available information, technical expertise, or access to new software. However, AASHTO already publishes a design policy for very low-volume rural local roads. Therefore, the resulting process may be able to identify a process simplified for lower-volume systems or establish a set of minimum criteria based on safety research.

### 8.4.6 Professional

A geometric design process that results in significant changes could have a ripple effect at the academic and professional level. It will be important to identify and consider what changes could influence the profession in this category.

- The revised geometric design process is envisioned to be accompanied by substantial re-write of AASHTO policies. This would be a multi-year effort, as was the case with the LRFD process. In addition to updating

the AASHTO policies, states would need to review and update their own manuals, guides and policies impacted by the revised design process. Updating state and local level documents will require additional time and cost as part of the implementation.

- A revised process, if having substantial changes from the existing process, would require universities and colleges to update their curriculum to instruct the next generation of design engineers on the revised processes and train them to use the tools. Similarly, professional licensing and testing requirements may need updating.
- A revised approach will require a significant effort of education targeted to both existing professionals and college students. Existing professionals may feel threatened or be resistant to change. For those accustomed to designing by pulling values from tables, the new process of designing to provide the best performance may be more complicated.
- Existing college curricula does not always prepare students with all the knowledge to be an informed roadway designer. Some college instructors lack the informed background or experience to provide students with be accomplished designers. Graduating students currently need training on the design tools as they enter the profession. This will continue to be the case with the revised process.

### 8.4.7 A State's Experience Implementing a Flexible Design Process

The Minnesota Department of Transportation undertook an initiative to provide for design flexibility in their project development process. The Design Flexibility Engineer at the Minnesota DOT [Jim Rosenow] shared several experiences and perspectives on this transition (2). The transition process the Minnesota DOT relies on establishes a focus on education & outreach, provides technical expertise to design staff in project development, and updates policies and criteria. With this approach, it is important to note that the first two elements, when well executed, makes it easier for the design community to accept and embrace updated policies and criteria that constitute the design process.

In order to accomplish these goals, two keys to the approach included:

- 1) Identify a staff person to work full-time to institutionalize the revised process.
- 2) Understand the design criteria, policies and decisions that have the largest financial impact on the project cost. Also identify those which are the easiest to implement from either a technical or design community acceptance perspective.

As shown in Figure 65, where criteria, policies or decision have high financial impact on the project outcome, but are easy to address either technically or from a design community acceptance viewpoint, then addressing these areas first should provide the greatest return on the agency's investment. Several examples that may fit this category, depending on a state's design approach, include:

- Designing long turn lane lengths in constrained environments, especially if volumes are low enough to allow the intersection to operate properly with shorter turn lanes.
- Economical cross-sections to avoid excessive earth work. For example, widening shoulders to standards on low volumes roads that have limited number of crashes, instead of using narrow shoulders with edge line or shoulder rumble strips, which may provide a similar safety performance.
- Interchange ramp design, such as selecting large radius for loop ramps or designing long ramps, which may increase right-of-way purchases.

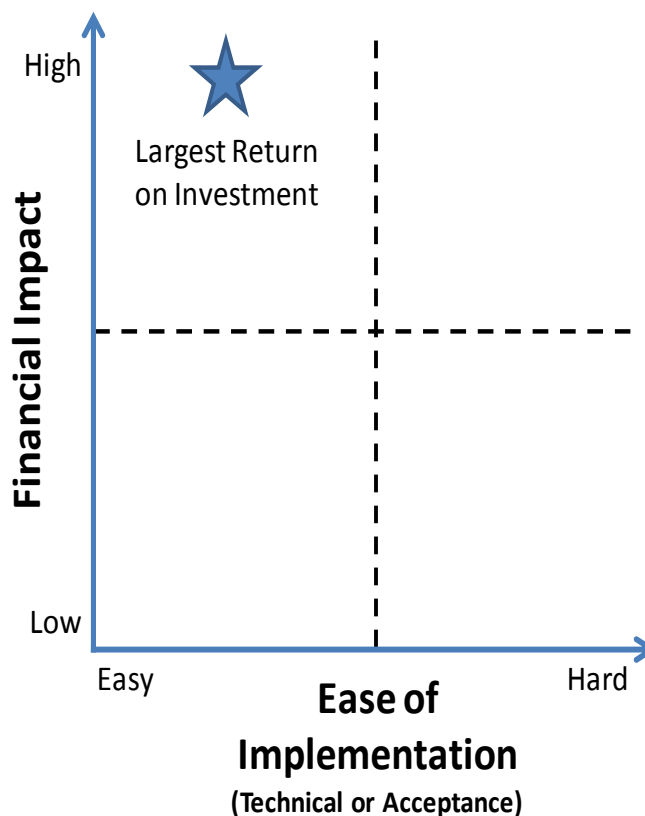

Figure 61. Understanding Financial Impact and Ease of Implementation for Individual Design Criteria and Policies

One example of success that has occurred in Minnesota is the viewpoint on alternative intersection designs. In Minnesota, the public and the design community both initially had reservations regarding the Restricted Crossing U-Turn (RCUT) as an option for rural expressways. Through outreach and education efforts, including working with other states, this intersection type is now viewed as an alternative to constructing interchanges at locations experiencing severe crashes. The safety performance of the RCUT has so far proven superior to the traditional through-STOP intersection, but could be constructed at a fraction of the cost of an interchange.

#### 8.4.8 Lessons Learned from Recent Process Changes

Based on experiences through the implementation of LRFD, CSS and the HSM, the following are offered as suggestions for a successful transition (1, 3, 4). Other positive driving forces may exist and will be used in the transition, but the following have proven to be critical to success.

**Identify a Champion.** Eventually, champions will need to be identified at numerous levels within each state DOT, including a liaison for technical transfer to the local and low-volume road authorities. However, the first step is a champion at the national level to communicate the need and benefit to key agencies, organizations (that is, FHWA and AASHTO), and executive managers at the state DOTs. This is a top-down approach to building support within the industry, but the advantage of an executive sponsor is their ability to make clear the importance of the transition.

**Adequately fund the transition.** As seen with the adoption of the LRFD process in bridge design, the training and software needs of the user community is crucial to minimizing individual resistance. Following the update of the



AASHTO policies, lead agencies, such as FHWA and AASHTO, must develop and fund a program to help train highway designers. This will include developing the training, training instructors, and then making courses available to community. In providing the training, it is important to consider the needs beyond the state DOTs. Local agencies, federal employees, and consultants will require the same training to make sure the revised process is fully implemented. LTAP centers and professional societies can be used to help train these groups. A final aspect of the training is considering the universities and colleges. Schools that teach design principles to students should understand the revised process and begin teaching it to the next generation of designers.

In addition to funding training, a revised geometric design process may require funding to develop supporting design software because the initial lack of supporting software was one reason noted for the resistance to LRFD. Therefore, any software envisioned to accompany a revised process should be available as quickly as possible. In developing the software, it will be important that it be affordable to the many local agencies, companies and schools otherwise unable to afford expensive software, such as SafetyAnalyst. It also needs to be fully tested to make sure it is easy to use and compatible with the other software used by designers.

**Update Design Guides and Policies.** AASHTO publishes several policies that most agencies use or base their own manuals, guides and policies upon. As a result of AASHTO's policies becoming industry standards, these documents will need to be updated to make them consistent with the revised geometric design process. This could include a supplemental recommended process guide as a companion to the design policies, minor changes to the policies or a completely new structure to the policies. Regardless, it is important that the new guides be in place if it is expected that agencies will be able to properly adopt and apply a revised geometric design process.

**Develop a lead state program.** FHWA successfully used lead state programs in several areas, including the integration of the HSM. A lead state program with support from FHWA and AASHTO provides real-world guidance and results in positive peer pressure on agencies and individuals not embracing the change. A lead state program also provides an opportunity to develop documentation that supports a transition. Example documentation may include a Data Needs report, a Manager's Guide, and an example Implementation Plan that other states might use to efficiently implement changes.

**Market successes.** Case studies are one approach to explaining and marketing benefits to the general audience. The message of each case study must clearly define and identify the benefits gained from the revised process. For example, a case study may demonstrate how the revised design process resulted in a different design decision that avoided a costly alternative. Equally important, a case study should be a project that after construction, the location has proven to operate efficiently and perform without major incident to demonstrate that there were minimal trade-offs in the design decision. Case studies can also highlight states that have been using performance-based or practical design processes, and the benefits these agencies have experienced.

## 8.5 Green Book Reorganization

The AASHTO Policy on Geometric Design (aka 'Green Book') is the core reference document from which state DOT design manuals and policies are derived. Road and highway designers must be thoroughly versant in both the contents of, and basic philosophy published in the Green Book.

The Green Book is updated about every seven to ten years. It evolved from a single policy document, to two documents encompassing separately rural and urban road design. Since the 1984 edition, when the two policies were combined into the one current policy, the basic structure of the Green Book has been largely unchanged. Of course, changes and additions to content have occurred (e.g., inclusion of geometric design of roundabouts) over the years. Yet, the basic format, structure, and indeed, design philosophy and approach has been constant.

A change in the approach to geometric design envisioned by this study would necessarily require a re-thinking and re-structuring of the Green Book. A primary driver is the separation of approaches for new vs. reconstruction projects. Other drivers include the more robust definitions of context discussed here, and the concept of differing models or assumptions for geometric elements based on context.

The Appendix contains a detailed outline of a future edition of the Green Book that would address the substantive advances presented by this research project. The outline, carried to a second heading level, is intended to facilitate a better understanding of the depth and breadth of necessary change, to lay out a vision for a future Green Book, and to demonstrate the practical implementation of such changes. Presenting such an outline also confirms the need for AASHTO to remain at the center of design policy, and for the Green Book to continue its dominant leadership role.

The following is a high level summary of the 13 page outline included in Appendix E. Note that the Green Book could be organized by four major parts. Note also the use of individual chapters for roads defined within the two-dimensional framework of functional classification and context zone. This structure allows for context design model, or approach that is unique to such roads to be covered fully just in the one chapter.

Although the outline appears lengthy, note that many designers would gravitate only to the specific chapters covering the project types they perform.

## 8.5.1 A Future Generation AASHTO Policy on Geometric Design

### Part I – Fundamentals of Geometric Design

Chapter 1 – Geometric Design and Project Development

Chapter 2 – The Geometric Design Framework

Chapter 3 – Road User Performance Characteristics

Chapter 4 – Elements of Geometric Design – Alignment and Cross Section

Chapter 5 – Elements of Geometric Design – Intersections and Roundabouts

Chapter 6 – Elements of Geometric Design – Interchanges and Interchange Ramps

Chapter 7 – Integration of Technology with Geometric Design

Chapter 8 – Overview of the Roadway Geometric Design Process

### Part II – Geometric Design for New Roads

Chapter 9 – New Road Construction Design Process Overview

Chapter 10 – New Local and Collector Roads in Rural Context Zones

Chapter 11 – New Arterial Roads in Rural Context Zones

Chapter 12 – New Freeways and Fully Controlled Access Highways in Rural Context Zones

Chapter 13 -- New Local and Collector Roads in Suburban Context Zones

Chapter 14 – New Arterial Roads in Suburban Context Zones

Chapter 15 – New Freeways and Fully Controlled Access Highways in Suburban Context Zones

Chapter 16 -- New Local and Collector Roads in Urban Context Zones

Chapter 17 -- New Arterial Roads in Urban Context Zones

Chapter 18 -- New Freeways and Fully Controlled Access Highways in Urban Context Zones

### Part 3 – Geometric Design Process for Roads to be Reconstructed

Chapter 19 – Reconstruction Design Process Overview

Chapter 20 -- Reconstructed Local and Collector Roads in Rural Context Zones

Chapter 21 -- Reconstructed Arterial Roads in Rural Context Zones

Chapter 22 -- Reconstructed Freeways and Controlled Access Facilities in Rural Context Zones

Chapter 23 – Reconstructed Local and Collector Roads in Suburban Context Zones

Chapter 24 -- Reconstructed Arterial Roads in Suburban Context Zones

Chapter 25 -- Reconstructed Freeways and Controlled Access Facilities in Suburban Context Zones

Chapter 26 -- Reconstructed Local and Collector Roads in Urban Context Zones

Chapter 27 -- Reconstructed Arterial Roads in Urban Context Zones

Chapter 28 -- Reconstructed Freeways and Controlled Access Facilities in Urban Context Zones

#### Part IV – Roads Requiring Resurfacing, Restoration or Rehabilitation ('3R')

Chapter 29 – 3R Design Process for All Road Types and Contexts

## 8.6 Implications with driverless/connected/autonomous technology

Advances in vehicle technology are accelerating. Specifically, there is much research and development work on automated driver technology (also referred to as autonomous vehicle technology). The vision of many is that, at some point in the future, vehicles will have sufficient means to interact with the roadway environment, and navigate in real time in response to that environment, thereby eliminating the human driver from the task of driving.

The benefits of this vision are primarily the presumed elimination of the human element from crash risk. IN theory, the existence of a network operated on by 100% autonomous vehicles would result in no crashes. Additional benefits may also accrue to improve the overall efficiency of the road system.

Given the historic role of the human driver in the formulation and application of geometric design, such a future vision would seem to have radical implications in the field of roadway design. The entire concept of roadside design to mitigate run-off-road crash frequency and severity would be rendered unnecessary. Cross section dimensions for lane and shoulder could be lessened considerably. Road capacity could be increased significantly through use of very small headways at high speeds. Stopping sight distance design would be based on locations of sensors, and assume much more responsive and aggressive avoidance maneuvers, thus greatly shortening necessary distances. Indeed, one might postulate that the presence of a 100% autonomous vehicle fleet essentially negates much of what currently constitutes geometric design controls.

It is beyond the scope of this project to delve further into the subject of autonomous vehicles, other than to offer the following observations.

- Full implementation of the autonomous vehicle technology is at best decades away. Research continues. The complexity of the urban driving environment will take some time for the technology to fully address. More importantly, it is not clear what the responsibilities of agencies will be to provide a roadway environment that is necessary for the technology to properly work. The potential liability and cost associated with a level of maintenance above that currently provided on all public roads is incalculable
- Even if/when such technology is sufficiently perfected, the existing vehicle fleet will remain on the system for 15 years or more. A very long transition period to full autonomous operation must occur, if indeed such operation is ever fully implemented.

- Societal and cultural issues need resolution. Specifically, does the presence of fully autonomous technology absolve a driver from any and all responsibility? If so, what are the limitations or requirements to obtain a driver's license; and what training is necessary?

What should AASHTO's approach be in considering the onset of autonomous vehicle technology to the subject of geometric road design criteria? The research team's recommendation is that, given the above significant issues, AASHTO must continue to adopt a basic design model that includes consideration of the human element and active human drivers as fundamental to design. However, to the extent that autonomous driver technology becomes more imbedded in the vehicle fleet, over time the potential benefits and impacts should be observable. This fact makes the performance-based approach to design all the more compelling. Over time, if fewer crashes occur of a given type (say, roadside) or headways reduce and capacity increases, these effects will be measured on the system. The tools used to determine design solutions (e.g., safety performance functions and CMFs) will evolve to include such effects. Cost effectiveness based on lower crash frequencies will produce different outcomes, such outcomes reflecting the evolution of the vehicle fleet. And those design elements insensitive to human driving limitations (e.g., vehicle offtracking) will be unchanged.



# Appendix A: Example Performance Criteria Memorandum



*Technical Memorandum*

# Sellwood Bridge Project Evaluation Framework

This memorandum outlines the approach for screening Sellwood Bridge Project concepts and evaluating alternatives adopted by the Policy Advisory Group on January 29, 2007. The outcome of this evaluation process will be the selection of a few alternatives to be analyzed in the Draft Environmental Impact Statement (Draft EIS).

## Screening and Evaluation Process

The evaluation framework includes two parts: screening and evaluation. The first part screens concepts against the minimum requirements of the project purpose and need. Threshold criteria represent this set of minimum requirements. In this screening process, if concepts do not meet the thresholds, they are considered infeasible and are dropped from consideration. Concepts that meet the threshold criteria are considered feasible and are developed into project alternatives.

The second step of the framework compares the project alternatives against a set of evaluation criteria. Evaluation criteria are used to compare the alternatives with one another to determine how they perform against a broad range of stakeholder values.

The performance of each of the project alternatives will be rated by technical staff for each evaluation criterion. The Community Task Force (CTF) will set a weighting factor for each criterion to establish its level of importance in relation to the other criteria. A total score (the sum of all the performance ratings times the weighting factors) will be calculated for each alternative, and an associated ranking of alternatives prepared. The higher the score, the more successfully the alternative matches the CTF values for the project. The ranking will be used by the CTF in developing its recommendation of alternatives to be evaluated further as part of the environmental documentation process.

The framework serves three primary purposes. First, it ensures that all project alternatives address the project's purpose and need. The threshold criteria determine the minimal requirements in relation to the Purpose and Need Statement. Second, it helps frame a discussion with a wide variety of stakeholders about what project features are most valuable. These values are reflected in the evaluation criteria. Third, it establishes the relative advantages and disadvantages of feasible alternatives to support selection of a few for further analysis in the Draft EIS.

The evaluation process for the Sellwood Bridge project is comprised of the following tasks:

- Develop threshold criteria
- Develop evaluation criteria
- Identify a broad range of concepts
- Evaluate concepts for feasibility
- Develop alternatives from feasible concepts
- Collect performance data for each criterion for each alternative
- Evaluate alternatives
- Select alternatives for more detailed analysis in the Draft EIS

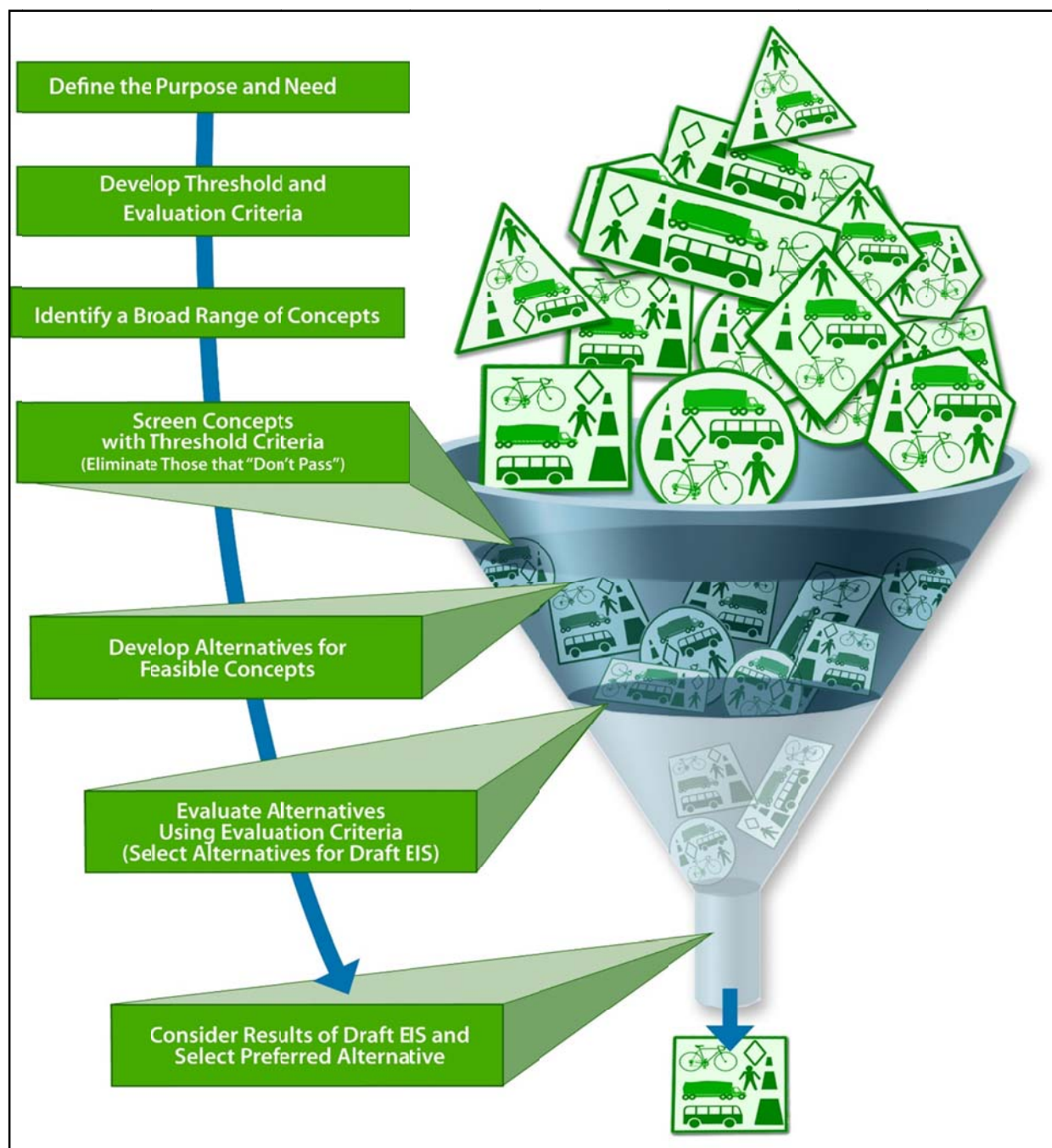

FIGURE A-1 – Screening and Evaluation Process

## Screening of Concepts Using Threshold Criteria

The first step of alternative evaluation is to compare a wide variety of concepts against a set of threshold criteria. Threshold criteria serve as a set of minimum requirements for project concepts before they can be developed into full-fledged alternatives. Concepts either meet the threshold criteria or they do not, and those that meet these criteria are deemed feasible. Threshold criteria are based on existing or readily available data, and may reflect regulatory or policy imperatives. Threshold criteria are used throughout the evaluation process to eliminate concepts or alternatives as more information becomes available.

Threshold criteria were initially prepared by the Project Management Team, reviewed and revised by participating agency staff, recommended by the CTF, and approved by the Policy Advisory Group.



Threshold criteria are directly linked to project needs specified in the Purpose and Need statement, as shown in Table 1 below.

Table A- 1. Sellwood Bridge Threshold Criteria

Number	Identified Project Need, from Project Purpose and Need Statement	Threshold Criteria
1	Provide structural capacity to accommodate safely various vehicle types, including transit vehicles, trucks, and emergency vehicles; and to withstand moderate seismic events.	<p>Concept must accommodate AASHTO<sup>1</sup>/ODOT legal loads. Replacement concepts must accommodate streetcar loading.</p> <p>Concept must meet the AASHTO/ODOT Load-and-Resistance Factor Design (LRFD) standard of 75 years.</p> <p>Concept must be built to meet current seismic standards, as per AASHTO/ODOT LRFD standards. Bridge rehabilitation concepts must meet Phase I seismic retrofit standards, as documented in the ODOT's 2004 Bridge Design and Drafting Manual.</p> <p>Concept must meet horizontal and vertical clearance requirements for the Willamette River, as per the U.S. Coast Guard.</p>
2	Provide a geometrically functional and safe roadway design.	<p>Concept must connect with Highway 43 on the west and with a District Collector or higher classified street on the east within 500 feet north or south of the existing Tacoma Street alignment.</p> <p>Concept must be designed to meet the geometric requirements as outlined in the project's geometric design criteria.<sup>2</sup> Bridge rehabilitation concepts can be considered with exceptions to the minimum width criteria (travel lane, median, shoulder, multi-use path); bridge replacement concepts must meet the minimum width criteria.</p> <p>Concept must provide for clearance over the existing railroad tracks on the east side of the Willamette River, as per American Railway Engineering and Maintenance of Right of Way Association (AREMA) standards.</p>
3	Provide for existing and future travel demands between origins and destinations served by the Sellwood Bridge.	<p>Concept must maintain or improve traffic-carrying capability when compared to the 2035 No Build alternative.</p> <p>Concept must continue to serve the travel markets it currently serves.</p>
4	Provide for connectivity, reliability, and operations of existing and future public transit.	<p>Concept must meet the minimum turning radius of 40' Tri Met buses.</p> <p>Concept must provide sufficient (23 foot) clearance over the existing railroad tracks on the west bank of the Willamette River, preserving that corridor for future streetcar extension or other public use.</p>
5	Provide for improved freight mobility to and across the bridge.	<p>Concept must accommodate the turning radius of the WB67 design vehicle.<sup>3</sup></p>
6	Provide for pedestrian and bicycle connectivity, mobility, and safety to and across the river in the corridor.	<p>Concept must provide minimum bicycle and pedestrian facilities as per the project's geometric design criteria. Bridge rehabilitation concepts can be considered with exceptions to the minimum width criteria (travel lane, median, shoulder, multi-use path), but must improve upon width of existing shared path for bicycles and pedestrians.</p> <p>Concept must provide connections to designated City Bikeways, City</p>

<sup>1</sup> AASHTO stands for the American Association of State Highway and Transportation Officials

<sup>2</sup> Project geometric design criteria are attached as Appendix 1.

<sup>3</sup> Wheelbase (WB) is the distance, in feet, measured between the front wheel axle of a vehicle and its most rear wheel axle. For a tractor-trailer semi, WB is measured from the front wheel axle of the tractor to the most rear wheel axle of its trailer. The WB67 design vehicle has 67' between the front and the rear wheel axles.

Number	Identified Project Need, from Project Purpose and Need Statement	Threshold Criteria
		Walkways, and City Off-Street Paths in the vicinity of the bridge. Concept must not preclude access to the river for boats and boat trailers at Powers Marine Park and Sellwood Park.

Concepts that meet each of the threshold criteria above are deemed feasible, and moved forward into the evaluation process.

## Evaluation of Feasible Alternatives Using Evaluation Criteria

Evaluation criteria are used to differentiate and identify trade-offs among feasible alternatives. To be most effective, an evaluation criterion must be measurable and well-defined. This ensures a common understanding of each criterion's meaning, and allows for a clear comparison among alternatives.

Evaluation criteria were developed by the CTF with input from the participating agencies and the public, recommended to the Policy Advisory Group for adoption, and forwarded to the Collaborative Environmental Transportation Agreement for Streamlining (CETAS) group and other participating agencies for concurrence. Some criteria important to stakeholders cannot be used for initial screening of alternatives due to lack of applicable data, but are included because they will be used later in the process for selection of a preferred alternative, during final design, or during the procurement of construction contractors.

*Note:* No criteria category is established for safety. Safety is considered in the design standards as well as throughout the evaluation criteria in relation to particular facility users -- bicyclists, pedestrians, automobiles, freight, and transit.

*Note:* No criteria category is established for sustainability. Sustainability considerations are reflected throughout the evaluation criteria. Sustainability means using, developing and protecting resources in a manner that enables people to meet current needs and provides that future generations can meet future needs. Sustainability is a broad and long-term concept that addresses quality of life and efficiency concerns from the joint perspective of environmental, economic and community objectives. It takes into account both local and global views, applying a timeframe that considers long term costs and benefits.

## Aesthetics

**Goal:** Ensure an aesthetically pleasing solution that enhances visual quality to the bridge, on the bridge, and from the communities on both sides of the river.

*Note:* Criteria 2 and 3 (in grey) will be used to select bridge types for consideration in the Draft EIS (following selection of alignment alternatives to be considered in the Draft EIS).

Table A- 2. Aesthetics Criteria

Criteria	Measure
1 Maximize flexibility in bridge design types.	Constructed scale (high, medium, low) to assess whether the alternative maintains flexibility to use different bridge design types.
2 Enhance pedestrian/bicycle experience on the bridge	Qualitative scale considering architectural detail, interpretive displays, viewing facilities/vantage points, and human scale.
3 Provide a structure that instills a sense of community pride	Qualitative scale considering of views of the bridge from the community and gateway treatments that provide a presence for the bridge.

Criteria		Measure
4	Preserve, enhance, or create views from the bridge	Qualitative scale considering quality of views provided from the bridge for bicyclists, pedestrians, and vehicle occupants.
5	Provide aesthetically pleasing intersection/interchange designs that instill a sense of community pride	Qualitative scale considering views of the intersections/interchanges from the community

## Bike and Pedestrian

**Goal:** Improve pedestrian and bicycle connectivity, mobility, and safety to and across the Sellwood Bridge.

Table A- 3. Bike and Pedestrian Criteria

1	Criteria	Measure
1	Maximize bicycle and pedestrian safety	Qualitative scale considering: <ul style="list-style-type: none"> <li>- Width of sidewalk</li> <li>- Width of bike facility</li> <li>- Width of travel lanes</li> <li>- Separation to minimize conflicts between bikes and pedestrians</li> <li>- One-way vs. two-way facilities</li> <li>- Separation to minimize conflicts between low and high speed bicyclists</li> <li>- Separation to minimize conflicts between motor vehicles and non-motorized users (including separation of bicycle and pedestrian facilities from travel lanes)</li> </ul>
2	Maximize convenient and direct connections for bicyclists and pedestrians	Qualitative scale considering: <ul style="list-style-type: none"> <li>- Out of direction travel</li> <li>- Grade</li> <li>- Ease of crossing of OR 43 and SE Tacoma</li> <li>- Connections to OR 43, SE Tacoma, cemetery access road, the regional trail network, and the north sidewalk on Macadam</li> </ul>

## Community Quality of Life

**Goal:** Protect and preserve the existing quality of life of the neighborhoods in the Sellwood Bridge influence area on both sides of the Willamette River.

*Note:* Criterion 10 (in grey) will be used in selection of the preferred alternative (following preparation of the Draft EIS).

Table A- 4. Community Quality of Life Criteria

Criteria	Measure
1 Minimize noise impacts caused by traffic on residents, businesses, bridge users and visitors	Assessment of predicted noise levels compared to the future No Build, based on traffic volumes and speeds, at the following locations: <ul style="list-style-type: none"> <li>- Riverfront condos</li> <li>- Mid-point of bridge</li> <li>- Powers Marine Park</li> <li>- Sellwood pool (in Sellwood Park)</li> </ul>
2 Minimize through traffic intrusion in Sellwood and South Portland neighborhoods	Comparison of average daily traffic volumes on neighborhood streets against future No Build alternative (using screenlines)
3 Minimize impacts to recreational facilities	Qualitative scale considering impact on recreational use, constructive use, and long-term construction impacts on recreation properties.
4 Preserve historic and archaeological resources along project corridor	Number of potentially significant historic properties and archaeological resources affected by alternative
5 Minimize residential relocations	Number of residential units displaced by alternative
6 Minimize residential impacts	Number of residences currently within 30 feet of the street that will have a reduced distance to the proposed alternative (loss of front yard space)
7 Minimize business relocations	Number of businesses displaced by alternative
8 Preserve viability of local businesses	Qualitative scale considering auto access, parking, visibility, and access for delivery trucks
9 Achieve consistency with adopted community plans	Qualitative scale considering consistency with relevant regional and local plans on both sides of the bridge (including Tacoma Main Street Plan) in terms of: <ul style="list-style-type: none"> <li>- Number of lanes</li> <li>- Classification</li> <li>- Presence of bicycle facilities and sidewalks</li> <li>- Bicycle and pedestrian connections</li> <li>- Accommodation of freight</li> <li>- Connection with the local street network</li> </ul>
10 Minimize disproportionately high and adverse impacts to minority and low income populations	(Results of the Environmental Justice analysis from Draft EIS)

## Automobile, Freight, and Emergency Vehicles

**Goal:** Improve freight and commuter mobility and safety. Minimize bottlenecks for freight, automobiles, and emergency services.

Table A- 5. Automobile, Freight, and Emergency Vehicles Criteria

Criteria	Measure
1 Minimize congestion delay in bridge area	Vehicle hours of delay along the following corridors: <ul style="list-style-type: none"> <li>- OR 43 between Lake Oswego and Taylors Ferry</li> <li>- Tacoma Street between 6<sup>th</sup> and 17<sup>th</sup></li> <li>- 99E to Taylor's Ferry</li> <li>- Hwy 224 to 17<sup>th</sup> to Macadam and Taylor's Ferry</li> <li>- Taylor's Ferry between Terwilliger and OR 43</li> </ul>
2 Improve accessibility to residences and businesses	Area within a 20-minute travel time contour from the center of the Sellwood Bridge
3 Minimize impact of incidents and allow the passing of emergency vehicles	Combined width of travel lane and shoulders (curb-to-curb)
4 Accommodate trucks	Combined width of travel lane and shoulders (curb-to-curb)
5 Retain flexibility to respond to future transportation needs along the corridor	Qualitative scale assessing ability to add capacity on the bridge alternative's alignment, or ability to add to the bridge alternative in the future.
6 Remain open to traffic during periods of required maintenance	Combined width of travel lane and shoulders (curb-to-curb)

## Construction

**Goal:** Minimize construction impacts and risks.

*Note:* Criterion 4 (in grey) will be used in selection of the preferred alternative (following preparation of the Draft EIS).

Table A- 6 Construction Criteria

Criteria	Measure
1 Minimize closure time	Estimated months of bridge closure during construction
2 Minimize construction time	Estimated months of construction time, defined as starting with construction mobilization and ending with the opening of the completed project.
3 Minimize travel impacts during construction	Length of detour route during construction for all modes.
4 Minimize impacts of demolition	(Results of construction impact analysis in Draft EIS)

## Cost and Economic Impacts

**Goal:** Design, build, and maintain a cost-effective project.

*Note:* Criterion 2 (in grey) will be used in selection of the preferred alternative (following preparation of the Draft EIS). Criterion 3 (in grey) will be considered during construction contracting procurement.

Table A- 7. Cost and Economic Impacts Criteria

Criteria	Measure
1 Minimize life cycle cost	Cost of design, construction, right-of-way acquisition, and maintenance in year of construction dollars
2 Stimulate the local economy	(Results of economic impact analysis from Draft EIS)
3 Provide contracting opportunities to disadvantaged, minority, women-owned, and emerging small businesses.	(Will be considered during construction contracting procurement)

## Natural Environment

**Goal:** Preserve or improve the natural environment.

*Note:* Criteria 8, 9, and 10 (in grey) will be used in selection of the preferred alternative (following preparation of the Draft EIS).

Table A- 8. Natural Environment Criteria

Criteria	Measure
1 Minimize impacts to floodplain; meet OTIA III floodplain/fluvial standards to the greatest extent practical	Cubic yards of fill encroachment in 100-year floodplain
2 Maximize benefits to threatened and endangered fish species and other fish habitat; minimize impacts	Cubic yards of pier encroachment in the floodway (ordinary high water level)
3 Maximize benefits to threatened and endangered terrestrial species; minimize impacts	Acres of impacted native planting habitat lost
4 Maximize benefits to wildlife habitat; minimize impacts	Acres of lost wildlife habitat
5 Maximize benefits to riparian areas; minimize tree loss	Square feet of tree canopy removed
6 Maximize benefits to air quality; minimize impacts	Number of intersections along a major collector or arterial within study area where primary approach exceeds volume-to-capacity ratio of 0.9 during the PM peak hour.
7 Preserve recreational fishing; maintain instream structure and cover	Location and square feet of instream structure and cover loss.
8 Meet or exceed the requirements for stormwater treatment, both for water quantity and water quality	(Results of water quality analysis from Draft EIS)
9 Minimize impacts to fish passage	(Results of biological analysis from Draft EIS)
10 Minimize wetland impacts and maximize benefits of avoidance, enhancement and	(Results of wetlands analysis from Draft EIS)

Criteria	Measure
replacement	

## Material Use

**Goal:** Use material resources as efficiently as possible.

*Note:* Criteria 2, 3 and 4 (in grey) will be considered in final design and construction contracting procurement.

Table A- 9 Material Use Criteria

Criteria	Measure
1 Maximize use of materials from existing bridge	Percentage of project materials obtained from existing bridge
2 During construction, maximize use of materials from existing bridge; reuse and recycle.	(Will be considered during final design and construction contracting procurement)
3 Reduce material used and waste generated.	(Will be considered during final design and construction contracting procurement)
4 Consider material resource impacts during other phases of the structure's life, such as maintenance/operation, and deconstruction/disposal	(Will be considered during final design and construction contracting procurement)

## Mass Transit

**Goal:** Improve mass transit circulation, capacity, connectivity, and local access to and across the bridge.

Table A- 10 Mass Transit Criteria

Criteria	Measure
1 Increase mass transit reliability	Qualitative scale considering mass transit travel times, based on ability to provide dedicated mass transit facilities or operational priority for mass transit and overall vehicle hours of delay.
2 Accommodate future streetcar or express transit alternatives	Qualitative scale considering number of lanes, geometrics, and load capacity
3 Ensure efficient cohabitation of mass transit and auto/truck traffic	Qualitative scale considering presence of dedicated bus pullouts, mass transit stops, transfer points
4 Ensure effective transit connectivity	Qualitative scale considering connectivity of all transit modes

## Seismic

**Goal:** Bridge should resist moderate earthquakes.

Table A- 11 Seismic Criteria

Criteria	Measure
1 Minimize loss of life, loss of property, and damages to bridge due to earthquake	Qualitative scale considering ability of bridge to resist moderate earthquake.



## Design Standards

## Sellwood Bridge Roadway Design Standards

Table A- 12 Sellwood Bridge Roadway Design Standards

Design Feature	Design Criteria	Source
Classification	District Collector Community Corridor City Bikeway City Walkway Minor Truck Street Major Emergency Response Street Transit Access Street	City of Portland's Transportation System Plan (TSP)
Design Vehicle	WB-67	Roadway Working Group
Design Speed	35 mph	City of Portland
Stopping Sight Distance	250 feet (design speed dependent)	AASHTO <sup>4</sup>
Minimum KSAG	49	AASHTO
Minimum KCREST	29	AASHTO
Vertical Clearance Above Other Roadways	17 feet <sup>5</sup>	ODOT HDM <sup>6</sup>
Vertical Clearance Above Railroads	23 feet	ODOT HDM
Maximum Grade	5%	Americans With Disabilities Act (ADA)
Minimum Grade	0.5% for standard curbed sections, >0.3% for curb and gutter sections	City of Portland's Design Guide for Public Street Improvements
Pavement Cross Slope	2.0% to 6.0%	City of Portland's Design Guide for Public Street Improvements
Maximum Superelevation	6.0%	AASHTO
Major Emergency Response Street	Major Emergency Response Routes are not eligible for traffic slowing devices.	City of Portland's Transportation System Plan

<sup>4</sup> American Association of State Highway and Transportation Officials: *A Policy on Geometric Design of Highways and Streets*, 2001.

<sup>5</sup> For a rehabilitation project, existing clearances between 16 and 17 feet may be maintained with notification to the Motor Carrier Transportation Division.

<sup>6</sup> Oregon Department of Transportation, Highway Design Manual.



			(TSP)
Travel Lane Width <sup>7</sup>	Minimum	Desirable	Min. – City of Portland Des. –Roadway Working Group
	11 feet	12 feet	
Bike Lane	On a designated City Bikeway, bicycle lanes recommended. Where not possible due to width constraints and parking needs, a parallel alternative should be developed.		Min. – City of Portland Bicycle Master Plan Des. – Roadway Working Group
	Minimum	Desirable	
	5 feet	6.5 feet	
Sidewalk	On a designated City Walkway, sidewalks are required to provide safe, convenient, and attractive pedestrian access to activities along streets and to recreation and institutions within and between neighborhoods. All construction of new public streets will include sidewalk improvements on both sides.		Min. – Portland Pedestrian Design Guide Des. – Roadway Working Group
	Minimum	Desirable	
	8 feet clear of obstructions (6 feet Through Pedestrian Zone plus 2 feet Furnishings Zone/Curb Zone).	12 feet clear of obstructions (6 feet Through Pedestrian Zone plus 2.5 feet Furnishings Zone/Curb Zone plus 1.5 feet Frontage Zone adjacent to bridge rail).	
Shared Use Path(if Bike and Ped facilities are combined) <sup>4</sup>	Minimum	Desirable	Min. – City of Portland Bicycle Master Plan Des. – Roadway Working Group
	16 feet clear of obstructions for a two-way path (12 feet plus 2 feet of shy on both sides)	20 feet clear of obstructions for two-way path (16 feet plus 2 feet of shy on both sides).	
Minimum Shoulder Width <sup>4</sup> (if no bike lane)	3 feet on bridges in excess of 100 feet.		AASHTO
Minimum Horizontal Curvature	R = 460 ft (Low speed, urban streets, normal crown) R = 320 ft (Low speed, urban streets, 6% superelevation)		AASHTO
Side slopes Cut Fill	2:1 Max 3:1 Max		City of Portland's Design Guide for Public Street Improvements

<sup>7</sup> The rehabilitation concepts, as currently developed, do not meet these minimum standards for width. A design exception would be required.



# Highway 43 Design Standards

Table A- 13 Highway 43 Design Standards

Design Feature	Design Criteria	Source
Classification	Non-Designated Urban Highway, Urban Fringe / Suburban	ODOT HDM <sup>8</sup>
Design Vehicle	WB-67	ODOT HDM
Design Speed	40 mph	ODOT HDM
Stopping Sight Distance	305 feet (design speed dependent)	ODOT HDM
Minimum KSAG	64	ODOT HDM
Minimum KCREST	70	ODOT HDM
Vertical Clearance	17 feet	ODOT HDM
Maximum Grade	7%	ODOT HDM
Minimum Grade	0.5% for standard curbed sections, >0.3% for curb and gutter sections	ODOT HDM
Minimum Cross Slope	2.0%	ODOT HDM
Maximum Superelevation	4.0%	ODOT HDM
Minimum Lane Widths		ODOT HDM
Travel Lanes	12 feet	
Medians		
Striped	2 feet	
Continuous Left Turn Lane	14 feet	
Raised Curb Median	16 feet Travel lane to travel lane	
Bike Lanes	8 feet	
Sidewalk	6 feet	
Shoulder(if no bike lane)	8 feet (10 feet with barriers)	
Shared Use Path	8 feet	
Maximum Degree of Curvature	10° 00' (573 feet radius), with 4% superelevation 1° 15' (4584 feet), with normal crown	ODOT HDM
Spirals	240 feet (2 Lanes) 360 feet (4 Lanes)	ODOT HDM
Side slopes		ODOT HDM
Cut	2:1 Max	
Fill	3:1 Max (with Guardrail) / 4:1 Max (without Guardrail)	
Access Spacing from interchange	1320 feet	ODOT HDM

<sup>8</sup> Oregon Department of Transportation, Highway Design Manual.



## Design Standards

## Highway 43 Interchange/Intersection Design Standards

Table A- 14. Highway 43 Interchange/Intersection Design Standards

Design Feature	Design Criteria	Source
Classification	Non-Freeway Ramps	ODOT HDM <sup>9</sup>
Design Vehicle	Design for WB-40 (accommodate WB-67) <sup>10</sup>	Roadway Working Group
Design Speed	25 mph	ODOT HDM
Stopping Sight Distance	155 feet	ODOT HDM
Minimum KSAG	26	ODOT HDM
Minimum KCREST	19	ODOT HDM
Vertical Clearance	17 feet	ODOT HDM
Maximum Grade	7% ascending, 8% descending	ODOT HDM
Minimum Grade	0.5% for standard curbed sections, >0.3% for curb and gutter sections	ODOT HDM
Minimum Cross Slope	2.0%	ODOT HDM
Maximum Superelevation	12%	ODOT HDM
Minimum Lane Widths Travel Lane Shoulder  Sidewalk	14 feet 6 feet Right Shoulder (8' with barrier) 2 feet Left Shoulder (4' with barrier) 6 feet	ODOT HDM
Radius	36° 00' (159.15 feet) with maximum superelevation.	ODOT HDM
Spirals	200 feet	ODOT HDM
Side slopes Cut Fill	2:1 Max 3:1 Max (with Guardrail) / 4:1 Max (without Guardrail)	ODOT HDM

Note: For at-grade intersections and roundabouts, the standards of the ODOT HDM, Section 9 will apply.

<sup>9</sup> Oregon Department of Transportation, Highway Design Manual.

<sup>10</sup> 'Accommodate' refers to the ability to make the maneuver by encroaching on other lanes, shoulders, or over mountable curbs. 'Design for' means the vehicle does not require encroachment.

# Appendix B: Review of the 2011 AASHTO Policy on Geometric Design

Geometric Design Element or Feature	2011 Green Book Reference		Empirical Performance Basis for Design Value(s)										Engineering Judgment Basis for Design Value(s)					
	Page(s)	Table or Figure	Vehicle-Based		Human Factors-Based		Quantitative Safety-Based		Traffic Flow-Based	Roadway Infrastructure Condition-Based	Context Sensitivity	Quality of the Empirical Research Basis		Rational Engineering Model	Aesthetic Criterion	Hypothesized Safety Performance	Hypothesized Traffic Operational Performance	Other
			Spatial	Operational Characteristics	Driver	Pedestrian or Cyclist	Crash Frequency	Crash Severity				Currency	Comments					
Design Vehicles -- Dimensions	2-1 to 2-35	Figure 2-1 to 2-23	X							NA	High	Vehicle types and dimensions updated to reflect vehicle fleet.						
Design Vehicles -- Turning Characteristics	2-6 2-7	Table 2-2		X						NA		Vehicle types and characteristics updated to reflect vehicle fleet. LOS is qualitative measure; but linked to quantitative measures for specific road types and conditions through reference to the TRB Highway Capacity Manual, which is frequently updated.						
Design Levels of Service	2-67	Table 2-5						X		Yes	High	Design Speed reflects context as defined by functional class, area type and terrain.						
Design Speeds	2-45 2-54	Table 2-3			X					Yes								
Stopping Sight Distance (SSD) (Level Roadways)	3-4	Table 3-1 and Equation 3-2	X	X	X					No	Moderate	Model input values recently updated per NCHRP Report 400.	X					
Stopping Sight Distance (on Grade)	3-5	Table 3-2 and Equation 3-3	X	X	X					NA	High							
Decision Sight Distance (DSD)	3-7	Table 3-3 based on Equations 3-4 and 3-5	X		X					Yes	Moderate	Need to check this.	X					
Passing Sight Distance (PSD)	3-9	Table 3-4	X	X	X					Yes (Applies only to 2-lane rural highways)	Moderate	Glennon and Hassan models validated by field studies.						
Minimum Length of PSD for Operational Analysis	3-14	Table 3-5			X			X		Yes (Applies only to 2-lane rural highways)	High							
Horizontal Curvature -- Minimum Radius for Given Design Speed and Superelevation Policy	3-32	Table 3-7 based on Equation 3-8			X					No	Low	Excludes effect of curve length, grade, type of transition; based on passenger car operations only.	X					
Horizontal Curvature -- Design Friction Factors	3-25 and 3-33	Figure 3-6		X	X				(x) -- Indirect	No	Low	Based on outdated observations of driver behavior in passenger cars with reference to available friction on pavement surfaces.	X					

Geometric Design Element or Feature	2011 Green Book Reference		Empirical Performance Basis for Design Value(s)										Engineering Judgment Basis for Design Value(s)					
	Page(s)	Table or Figure	Vehicle-Based		Human Factors-Based		Quantitative Safety-Based		Traffic Flow-Based	Roadway Infrastructure Condition-Based	Context Sensitivity	Quality of the Empirical Research Basis		Rational Engineering Model	Aesthetic Criterion	Hypothesized Safety Performance	Hypothesized Traffic Operational Performance	Other
			Spatial	Operational Characteristics	Driver	Pedestrian or Cyclist	Crash Frequency	Crash Severity				Currency	Comments					
Maximum Superelevation	3-44 to 3-51	Table 3-8 to 3-12								Yes (Climate)	Low				Selected maximum rate to reflect risk of sliding down curve under icy/low speed conditions.			
Minimum Radii and Superelevation for low speed urban streets	3-54 to 3-55	Table 3-13 based on								Yes (Urban)								
Radii for Compound Curvature										No				X				
Curve Lengths for Compound Curvature	3-58	Table 3-14								No						X		
Maximum Relative Gradient for Superelevation Runoff	3-61	Table 3-15								No				X		X (comfort)		
Adjustment Factor for Length of Superelevation Runoff for Number of Lanes Rotated	3-62	Table 3-16								No				X		X (comfort)		
Superelevation Runoff Lr for Horizontal Curves	3-64 to 3-65	Table 3-17 based on Equation 3-23							X (reference to drainage)					X		X (comfort)		
Limiting Superelevation Rates	3-68	Table 3-18														X ('excessive lateral shift')		
Superelevation Transition -- Length of Spiral Curvature	3-70	Equation 3-25								No	Low	Railroad Operations				X (Comfort)		
Minimum Length of Spiral Curve	3-71	Equations 3-26 & 3-27								No						X (Comfort and vehicle path)		
Maximum Length of Spiral Curve	3-72	Equation 3-28				X				No	Moderate*	International research on driver perception of spirals (not directly referenced). Based on 2.0 sec travel time per driver behavior per NCHRP 439.	X			2.0 sec of travel time at design speed		
Desirable Length of Spiral Curve	3-73	Table 3-21				X				No	High					2.0 sec of travel time at design speed		
Superelevation Rates Associated with Large Relative Gradients	3-74	Table 3-22											50 percent increase in relative gradient (anecdotal)	X ('Appearance')		X (comfort)		
Tangent Runout Length for Spiral Curve Transition Design	3-75	Table 3-23 based on Equation 3-29														X (comfort)		
Minimum Lengths of Spiral for Intersection Curves	3-83	Table 3-24											X - C (rate of change of lateral acceleration) is assumed to be able to vary from that used on open road curves			X (comfort)		

Geometric Design Element or Feature	2011 Green Book Reference		Empirical Performance Basis for Design Value(s)										Engineering Judgment Basis for Design Value(s)					
	Page(s)	Table or Figure	Vehicle-Based		Human Factors-Based		Quantitative Safety-Based		Traffic Flow-Based	Roadway Infrastructure Condition-Based	Context Sensitivity	Quality of the Empirical Research Basis		Rational Engineering Model	Aesthetic Criterion	Hypothesized Safety Performance	Hypothesized Traffic Operational Performance	Other
			Spatial	Operational Characteristics	Driver	Pedestrian or Cyclist	Crash Frequency	Crash Severity				Currency	Comments					
Length of Circular Arc for a Compound Intersection Curve When Followed by a Curve of One-Half Radius or Preceded by a Curve of Double Radius	3-84	Table 3-25												X (reference to 'smooth transition')			X (deceleration at a 'reasonable rate')	
Traveled Way Widening on Open Highway Curves		Table 3-26 based on Equations 3-31, 3-32 and 3-33	X	X														
Adjustments for Traveled Way Widening on Open Highway Curves	3-96	Table 3-27 amnd Figure 3-19	X	X						Yes -- Low Speed and large vehicles								
Pavement Widths for Turning Roadways for Range of Design Vehicles		Table 3-28	X	X														
Design Widths of Pavements for Turning Roadways		Table 3-29	X	X														
Range of Usable Shoulder Widths or Equivalent Lateral Clearances Outside of Turning Roadways, Not on Structure	3-106	Table 3-30	X	X														
Horizontal Sight Distance	3-109	Figure 3-23 and Equation 3-36											X	X				
Minimum Length of Horizontal Curve for Small Deflection Angles	3-111													X				Avoid the appearance of a kink
Minimum Length of Horizontal Curve for Main Highways	3-111												X (L in ft. = 3V with V in mph	X				
Minimum Length of Horizontal Curve for High Speed Controlled Access Facilities	3-111												X (L in ft. = 6V with V in mph	X				
Optimal Passing Lane Lengths	3-135	Table 3-31											X					
Lengths of Turnouts Including Taper	3-139	Table 3-32																X (A minimum length so that delayed vehicles have an opportunity to complete at least one pass in the added lane).
Emergency Escape Ramps	3-142	Table 3-33		X						X -- rolling resistance of materials	Yes	High	Based on vehicle research	X				X (Speed of entry and deceleration/braking to full stop).
Length of Crest Vertical Curves	3-155	Table 3-34	X		X						No	Low	Based on stopping sight distance model	X				X -- Full stop from design speed under hard braking.
Length of Crest Vertical Curves for Passing	3-157	Table 3-35	X		X						Yes	High	Based on Passing Sight Distance	X				X -- Enable passing maneuver per PSD model.
Length of Sag Vertical Curves	3-160	Equation 3-51		X	X						No	Low	Driver Comfort					Centripetal acceleration < 1 ft/s <sup>2</sup> .

Geometric Design Element or Feature	2011 Green Book Reference		Empirical Performance Basis for Design Value(s)										Engineering Judgment Basis for Design Value(s)					
	Page(s)	Table or Figure	Vehicle-Based		Human Factors-Based		Quantitative Safety-Based		Traffic Flow-Based	Roadway Infrastructure Condition-Based	Context Sensitivity	Quality of the Empirical Research Basis		Rational Engineering Model	Aesthetic Criterion	Hypothesized Safety Performance	Hypothesized Traffic Operational Performance	Other
			Spatial	Operational Characteristics	Driver	Pedestrian or Cyclist	Crash Frequency	Crash Severity				Currency	Comments					
Length of Sag Vertical Curves	3-161	Table 3-36	X							Yes	Moderate	Stopping sight distance at night (headlight beam)	X				X -- Full stop from design speed under hard braking.	
Sight Distance at Undercrossings	3-162	Figure 3-45	X			X												
Maximum Rollover	4-3	Figure 4-2		X						No	Disproven	See FHWA Research -- Glennon, J.C., T.R. Neuman, R.R. McHenry, and B.G. McHenry, HVOSM Studies of Cross Slope Breaks on Highway Curves, Phase II Task C, Report No. FHWA-RD-82-54, Federal Highway Administration, May 1982.	X -- Loss of control due to crossover; simulation research demonstrated that effective adverse slope and not crossover maneuver was controlling factor					
Cross Slope	4-6	Table 4-1							X -- Drainage	Yes	High				X -- Drain water from pavement			
Lane Width	4-7	In Text 9-12ft	X						X	Yes	Moderate	Based on range of factors					passing opposing vehicles	Availability of space ('stringent controls'); presence of pedestrians
Shoulder Width	4-8	In Text 2-12ft	X							Yes	Moderate	Based on range of factors					X- Too wide shoulders may encourage unauthorized use; also reference to widths where bicycles and pedestrians are to be accommodated.	
Noise Abatement Criteria	4-43	Table 4-2								Yes	High							X -- Environmental control (Noise)
Minimum Design Speeds for Local Roads	5-2	Table 5-1								Yes			Based on location and terrain (i.e., generalized cost-effectiveness)				Driver speeds will not exceed selected design speed	
Design Level of Service for Local Roads	5-3	In Text							X	Yes							LOS D; consistent with primary 'access' function; no reference to pedestrian or bicycle needs	
Maximum Grades for Local Roads	5-3	Table 5-2		X						Yes	Low						Access at minimal cost and impact	Few trucks, low speeds; no reference to bicycles
Stopping Sight Distance and Crest Vertical Curves	5-4	Table 5-3	X	X						No	Moderate	Model input values recently updated per NCHRP Report 400	X					
Crest Vertical Curves Based on Passing Sight Distance	5-5	Table 5-4								Yes	High	Glennon and Hassan models validated by field studies.					Enable passing per PSD model	



Geometric Design Element or Feature	2011 Green Book Reference		Empirical Performance Basis for Design Value(s)										Engineering Judgment Basis for Design Value(s)					
	Page(s)	Table or Figure	Vehicle-Based		Human Factors-Based		Quantitative Safety-Based		Traffic Flow-Based	Roadway Infrastructure Condition-Based	Context Sensitivity	Quality of the Empirical Research Basis		Rational Engineering Model	Aesthetic Criterion	Hypothesized Safety Performance	Hypothesized Traffic Operational Performance	Other
			Spatial	Operational Characteristics	Driver	Pedestrian or Cyclist	Crash Frequency	Crash Severity				Currency	Comments					
Minimum Width of Traveled Way and Shoulders	5-6	Table 5-5					X	X	X	X	Yes	Moderate	Cost-effectiveness from NCHRP Report 362.					
Minimum Clear Roadway Widths and Design Loadings for New and Reconstructed Bridges	5-7	Table 5-6							Yes (Traffic Volume)	Loading criteria set by Policy	No					Avoid conflicts with bridge ends and bridge rails on narrow bridges		
Minimum Structural Capacities and Minimum Roadway Widths for Bridges to Remain in Place	5-8	Table 5-7							Yes (Traffic Volume)	Loading criteria set by Policy	No		Generalized Cost-effectiveness Principles (reference to both traffic volume levels and length of bridge)				Lesser values acceptable with 'few trucks'	Consider 'remaining structure life, pedestrian volume, snow storage, design speed, and crash history'
Cul-de-Sacs and Turnarounds	5-17	Figure 5-1	X	X					Yes (selection of vehicle type)			High	Based on design vehicle characteristics					
Maximum Grades for Recreational Roads	5-26	Table 5-8	X	X														
Design Controls for Stopping Sight Distance and for Crest and Sag Vertical Curves—Recreational Roads	5-27	Table 5-9											Model input values recently updated per NCHRP Report 400					
Design Controls for Passing Sight Distance for Crest Vertical Curves—Recreational Roads	5-29	Table 5-10											Glennon and Hassan models validated by field studies					
Widths of Traveled Way and Shoulders—Recreational Roads	5-30	Table 5-11	X	X										X				
Design Speeds for Resource Recovery and Local Service Roads	5-33	Table 5-12		X							Yes							
Minimum Design Speeds for Rural Collectors	6-2	Table 6-1									Yes							
Maximum Grades for Rural Collectors	6-3	Table 6-2		X							Yes	Low					Access at minimal cost and impact	Few trucks, low speeds; no reference to bicycles.
Design Controls for Stopping Sight Distance and for Crest and Sag Vertical Curves	6-4	Table 6-3											Model input values recently updated per NCHRP Report 400					
Design Controls for Crest Vertical Curves Based on Passing Sight Distance	6-5	Table 6-4											Glennon and Hassan models validated by field studies					
Minimum Width of Traveled Way and Shoulders	6-6	Table 6-5					X	X	X	X	Yes; reference to 'roads to remain'	Moderate	Cost-effectiveness from NCHRP Report 362 (note that this research predates the AASHTO Highway Safety Manual and advances in crash frequency modeling).					
Minimum Roadway Widths and Design Loadings for New and Reconstructed Bridges	6-7	Table 6-6																

Geometric Design Element or Feature	2011 Green Book Reference		Empirical Performance Basis for Design Value(s)										Engineering Judgment Basis for Design Value(s)					
	Page(s)	Table or Figure	Vehicle-Based		Human Factors-Based		Quantitative Safety-Based		Traffic Flow-Based	Roadway Infrastructure Condition-Based	Context Sensitivity	Quality of the Empirical Research Basis		Rational Engineering Model	Aesthetic Criterion	Hypothesized Safety Performance	Hypothesized Traffic Operational Performance	Other
			Spatial	Operational Characteristics	Driver	Pedestrian or Cyclist	Crash Frequency	Crash Severity				Currency	Comments					
Structural Capacities and Minimum Roadway Widths for Bridges to Remain in Place	6-8	Table 6-7																
Maximum Grades for Urban Collectors	6-12	Table 6-8								Yes	Low						No reference to pedestrian or bicycle needs	
Minimum Sight Distances for Arterials	7-3	Table 7-1	X	X	X					No	Moderate	Model input values recently updated per NCHRP Report 400	X					
Maximum Grades for Rural Arterials	7-4	Table 7-2	X	X													...reflect the operational characteristics of an arterial.'	
Minimum Width of Traveled Way and Usable Shoulder for Rural Arterials	7-5	Table 7-3								Yes; reference to 'roads to remain'	Moderate	Cost-effectiveness from NCHRP Report 362 (note that this research predates the AASHTO Highway Safety Manual and advances in crash frequency modeling)						
Maximum Grades for Urban Arterials	7-29	Table 7-4	X	X													steep grades affect truck speeds and stopping distances, as well as the overall capacity.'	Also considers intersection operations during adverse weather and ability to provide accessible adjacent pedestrian facilities.
Freeway Level of Service	8-2								X	Yes	Low						Reference to LOS C to D for urban freeways is impractical and inconsistent with HOV, HOT and ramp metering as solutions.	
Maximum Grades for Rural and Urban Freeways	8-4	Table 8-1								Yes								
Level of Service Definitions for Signalized Intersections	9-8	Table 9-1										TRB Highway Capacity Manual						
Comparison of Roundabout Types	9-22	Table 9-2	X	X	X				X	Yes (Design Speed)	High	Based on research summarized in 'Roundabouts – An Informational Guide'						
Length of Sight Triangle Leg—Case A, No Traffic Control	9-33	Table 9-3	X						X									
Adjustment Factors for Sight Distance based on Approach Grade	9-35	Table 9-4		X					X									
Time Gap for Case B1, Left Turn from Stop	9-37	Table 9-5		X	X				X	No	High	NCHRP Report 383						
Design Intersection Sight Distance—Case B1, Left Turn from Stop	9-38	Table 9-6		X	X				X	No	High	NCHRP Report 383						

Geometric Design Element or Feature	2011 Green Book Reference		Empirical Performance Basis for Design Value(s)										Engineering Judgment Basis for Design Value(s)					
	Page(s)	Table or Figure	Vehicle-Based		Human Factors-Based		Quantitative Safety-Based		Traffic Flow-Based	Roadway Infrastructure Condition-Based	Context Sensitivity	Quality of the Empirical Research Basis		Rational Engineering Model	Aesthetic Criterion	Hypothesized Safety Performance	Hypothesized Traffic Operational Performance	Other
			Spatial	Operational Characteristics	Driver	Pedestrian or Cyclist	Crash Frequency	Crash Severity				Currency	Comments					
Time Gap for Case B2—Right Turn from Stop and Case B3—Crossing Maneuver	9-40	Table 9-7.		X	X				X		No	High	NCHRP Report 383					
Design Intersection Sight Distance—Case B2, Right Turn from Stop, and Case B3, Crossing Maneuver	9-41	Table 9-8.		X	X				X		No	High	NCHRP Report 383					
Case C1—Crossing Maneuvers from Yield-Controlled Approaches, Length of Minor Road Leg and Travel Times	9-45	Table 9-9		X	X				X		No	High	NCHRP Report 383					
Length of Sight Triangle Leg along Major Road—Case C1, Crossing Maneuver at Yield-Controlled Intersections	9-47	Table 9-10		X	X				X		No	High	NCHRP Report 383					
Time Gap for Case C2, Left or Right Turn	9-49	Table 9-11		X	X				X		No	High	NCHRP Report 383					
Design Intersection Sight Distance—Case C2, Left or Right Turn at Yield-Controlled Intersections	9-49	Table 9-12		X	X				X		No	High	NCHRP Report 383					
Time Gap for Case F, Left Turns from the Major Road	9-51	Table 9-13		X	X				X		No	High	NCHRP Report 383					
Intersection Sight Distance—Case F, Left Turn from the Major Road Edge-of-Traveled-Way Designs for Turns at Intersections—Simple Curve Radius with Taper	9-52	Table 9-14		X	X				X		No	High	NCHRP Report 383					
	9-57	Table 9-15	X	X							No	High	Design Vehicle Characteristics					
Edge-of-Traveled-Way Designs for Turns at Intersections—Three-Centered Curves Cross Street Width Occupied by Turning Vehicle for Various Angles of Intersection and Curb Radii	9-60	Table 9-16	X	X							No	High	Design Vehicle Characteristics					
	9-86	Table 9-17	X	X							No	High	Design Vehicle Characteristics					
Typical Designs for Turning Roadways	9-113	Table 9-18	X	X							Yes	High	Design Vehicle Characteristics					
Effective Maximum Relative Gradients	9-116	Table 9-19									No			X		X (comfort)	Reference to intersection turning roadway operations.	
Maximum Algebraic Difference in Cross Slope at Turning Roadway Terminals	9-121	Table 9-20		X							No	Disproven	See FHWA Research -- Glennon, J.C., T.R. Neuman, R.R. McHenry, and B.G. McHenry, HVOSM Studies of Cross Slope Breaks on Highway Curves, Phase II Task C, Report No. FHWA-RD-82-54, Federal Highway Administration, May 1982.	X -- Loss of control due to crossover; simulation research demonstrated that effective adverse slope and not crossover maneuver was controlling factor.				

Geometric Design Element or Feature	2011 Green Book Reference		Empirical Performance Basis for Design Value(s)										Engineering Judgment Basis for Design Value(s)					
	Page(s)	Table or Figure	Vehicle-Based		Human Factors-Based		Quantitative Safety-Based		Traffic Flow-Based	Roadway Infrastructure Condition-Based	Context Sensitivity	Quality of the Empirical Research Basis		Rational Engineering Model	Aesthetic Criterion	Hypothesized Safety Performance	Hypothesized Traffic Operational Performance	Other
			Spatial	Operational Characteristics	Driver	Pedestrian or Cyclist	Crash Frequency	Crash Severity				Currency	Comments					
Stopping Sight Distance for Turning Roadways	9-123	Table 9-21	X	X	X						No	Moderate	Model input values recently updated per NCHRP Report 400					
Desirable Full Deceleration Lengths	9-126	Table 9-22	X	X	X													
Guide for Left-Turn Lanes on Two-Lane Highways	9-132	Table 9-23	X	X														
Minimum Designs for U-Turns	9-166	Table 9-30	X	X														
Access separation and control distances	10-8,9	Figure 10-2												X			Rational model sums the distances required for merging, lane changing, deceleration and storage in left turn lane for vehicle entering crossroad from ramp.	No values given; rather a 'performance-based' method for deriving values.
Lateral Off set for Major Roadway Underpasses	10-20	Figure 10-6						X (speed and presence of walkways cited)	X (performance characteristics of selected roadside barrier)			High	Reference to AASHTO Roadside Design Guide for details; performance of barriers is based on research crash tests and established protocols set by policy.					
Guide Values for Ramp Design Speed as Related to Highway Design Speed	10-89	Table 10-1												X			X -- Meet driver expectations for speed on ramps	
Minimum Length of Taper Beyond an Offset Nose	10-99	Table 10-2												X	(X)			Basis for dimensions is not explained; suspected to be aesthetics; no established performance criteria for 'Z' value is known.
Recommended Minimum Ramp Terminal Spacing	10-106	Figure 10-68						X		Yes	No - outdated	NCHRP Report 687 should be referenced to update.						
Minimum Acceleration Lengths for Entrance Terminals with Flat Grades of Two Percent or Less	10-110	Table 10-3		X				X		No	Update per NCHRP Report 730							
Speed Change Lane Adjustment Factors as a Function of Grade	10-111	Table 10-4		X				X		Yes	Update per NCHRP Report 730							
Minimum Deceleration Lengths for Exit Terminals with Flat Grades of Two Percent or Less	10-115	Table 10-5		X				X		No	Update per NCHRP Report 730							

## Appendix C: Horizontal Curve Analysis



# Demonstration of Cost-effectiveness Approach to Horizontal Curve Design Policy

Horizontal curvature has a proven effect on substantive safety performance and operational performance. This Appendix demonstrates how the knowledge base can be applied to develop a more performance-based approach to geometric design processes and criteria for horizontal curvature. For illustrative purposes the focus is on two-lane rural highways, but a similar approach may be applied to other road types and contexts.

## Safety Performance

The AASHTO HSM describes the safety effect of curvature for two-lane rural highways. Crash frequency is a function of the radius of curve, length of curve and traffic volume. The research team assembled a spreadsheet to describe the predicted, uncalibrated crash frequency using the Chapter 10 model for curvature, with the following assumptions:

- 12 foot lane width
- 6 foot shoulder width
- Paved shoulder
- Roadside Hazard Rating of 3
- 5 driveways per mile
- Flat vertical alignment
- No centerline rumble strips, passing lanes, lighting, or automated speed enforcement
- Superelevation within AASHTO Policy values
- No spiral transitions
- Average Daily Traffic ranging from 400 to 17500 vpd

Comparison of differing curve designs requires a common section definition. An analysis segment was set consistent with that produced by alignment defined by a 3000 foot radius curve for a range of central angles, with the greatest being a 90 degree central angle, which produces a curve length of 0.8925 mi.

For curves with radii less than 3000 feet, the same starting and ending points apply (for a given central angle). *In other words, when comparing curves using different radii, a comparable section is one defined by the central angle of the curve.* An alignment with common starting and ending points and lesser radius would be comprised of a combination of tangents and curve, with the tangents increasing in length as the radius decreases. Given the geometry of horizontal curves, one can compute the long tangent of the curve, which thus produces the tangent alignment based on the set PC and PT. As the starting and ending points are based on the PC and PT of the 3000-foot radius, the length of alignment that is tangent within the section is 0, and the length of alignment that is curved is given by the computed curve length for a 3000 foot radius and given central angle.

Table B1 shows the alignment design values for an array of central angles from 15 degrees to 90 degrees. As the curve radius changes, the amount of alignment that is tangent versus curved changes. The implications of this are as follows:

- The smaller the radius, the less of the alignment is subject to the effect of curvature on crashes.
- The smaller the radius, the longer the total travel distance is (the shortest distance for any central angle is that produced by the greatest radius, in the case here, 3000 feet).

Table C- 1. HSM Predicted Annual Crashes for Varying Combinations of Radius, Central Angle, and Volume

Radius	Central Angle	Travel Distance	Total Predicted Crashes by Volume							
			400	1,000	2,500	4,000	5,500	7,000	8,500	10,000
500	15	1.136	0.132	0.331	0.828	1.325	1.822	2.319	2.815	3.312
	30	1.135	0.132	0.331	0.827	1.324	1.820	2.317	2.813	3.309
	45	1.132	0.132	0.330	0.825	1.321	1.816	2.311	2.806	3.302
	60	1.126	0.131	0.329	0.821	1.314	1.807	2.300	2.793	3.285
	75	1.115	0.130	0.326	0.814	1.302	1.790	2.279	2.767	3.255
	90	1.096	0.128	0.320	0.801	1.282	1.762	2.243	2.723	3.204
1,000	15	1.136	0.127	0.317	0.793	1.269	1.745	2.221	2.698	3.174
	30	1.134	0.127	0.317	0.792	1.267	1.742	2.218	2.693	3.168
	45	1.128	0.126	0.315	0.788	1.261	1.734	2.207	2.680	3.153
	60	1.116	0.125	0.312	0.780	1.248	1.716	2.184	2.652	3.120
	75	1.094	0.122	0.306	0.765	1.224	1.683	2.142	2.601	3.060
	90	1.055	0.118	0.296	0.739	1.183	1.626	2.070	2.514	2.957
1,500	15	1.136	0.125	0.313	0.782	1.251	1.720	2.189	2.658	3.127
	30	1.133	0.125	0.312	0.780	1.248	1.715	2.183	2.651	3.119
	45	1.124	0.124	0.310	0.774	1.238	1.703	2.167	2.631	3.096
	60	1.106	0.122	0.305	0.762	1.219	1.676	2.133	2.590	3.047
	75	1.072	0.118	0.296	0.739	1.183	1.626	2.070	2.513	2.957
	90	1.014	0.112	0.280	0.701	1.121	1.541	1.962	2.382	2.802
2,000	15	1.136	0.124	0.310	0.776	1.241	1.707	2.173	2.638	3.104
	30	1.132	0.124	0.309	0.773	1.237	1.701	2.165	2.629	3.093
	45	1.120	0.122	0.306	0.765	1.225	1.684	2.143	2.602	3.062
	60	1.096	0.120	0.300	0.749	1.199	1.648	2.097	2.547	2.996
	75	1.051	0.115	0.288	0.719	1.151	1.582	2.014	2.445	2.877
	90	0.974	0.107	0.267	0.668	1.068	1.469	1.870	2.270	2.671
2,500	15	1.136	0.124	0.309	0.772	1.236	1.699	2.163	2.626	3.089
	30	1.131	0.123	0.308	0.769	1.230	1.692	2.153	2.614	3.076
	45	1.116	0.121	0.304	0.759	1.215	1.670	2.126	2.581	3.037
	60	1.085	0.118	0.296	0.739	1.182	1.625	2.069	2.512	2.955
	75	1.030	0.112	0.281	0.701	1.122	1.543	1.964	2.385	2.806
	90	0.933	0.102	0.255	0.637	1.019	1.402	1.784	2.166	2.548
3,000	15	1.136	0.123	0.308	0.770	1.232	1.694	2.156	2.618	3.080
	30	1.129	0.123	0.306	0.766	1.225	1.685	2.144	2.604	3.063
	45	1.112	0.121	0.302	0.754	1.207	1.659	2.112	2.564	3.017
	60	1.075	0.117	0.292	0.730	1.168	1.605	2.043	2.481	2.919
	75	1.008	0.110	0.274	0.685	1.096	1.507	1.918	2.329	2.740
	90	0.892	0.097	0.243	0.608	0.972	1.337	1.701	2.066	2.431

For any given deflection angle, a comparative alignment design thus involves differing tangent and curve lengths based on the radii being compared. For example, comparing a 45 degree central angle with radii of 500 feet and 1500 feet yields the following (Figure 1):

- 3000 foot radius → 0.4462 mi. length of curve (PC to PT); 0.0 tangent length; and travel distance of 0.4462 mi.
- 1500 foot radius → 0.2231 mi. length of curve (PC' to PT'); 0.901 mi. total tangent length (PC to PC' + PT' to PT); and travel distance of 1.124 mi.



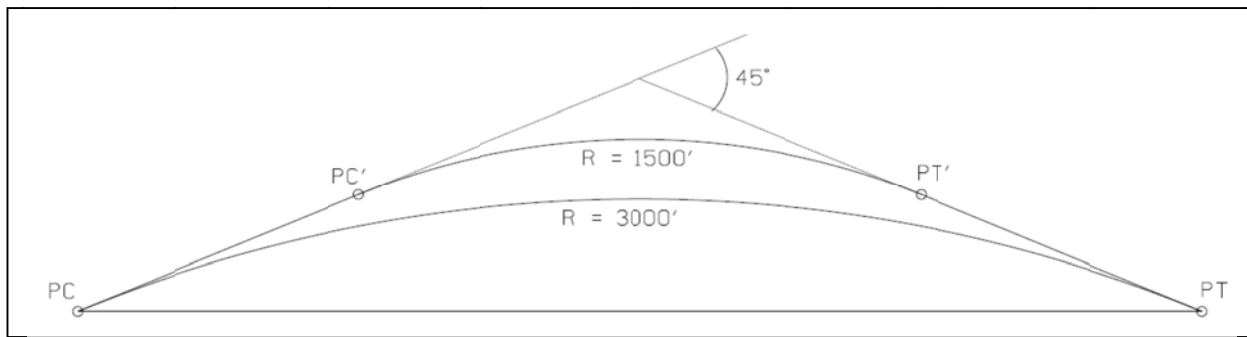

Figure C- 1. Comparison of Travel Distance with Same Central Angle

One can compute the crash frequency for each combination of tangent/curve alignment produced by the radii and central angles, using the HSM models for curvature and tangent, applying each to the appropriate length for the given design condition. These are shown in Table B1, which shows predicted annual crashes. Figures B2 through B7 display the results graphically.

For ease of understanding, consider Tables B2 and B3 which demonstrate a small subsection of Table B1.

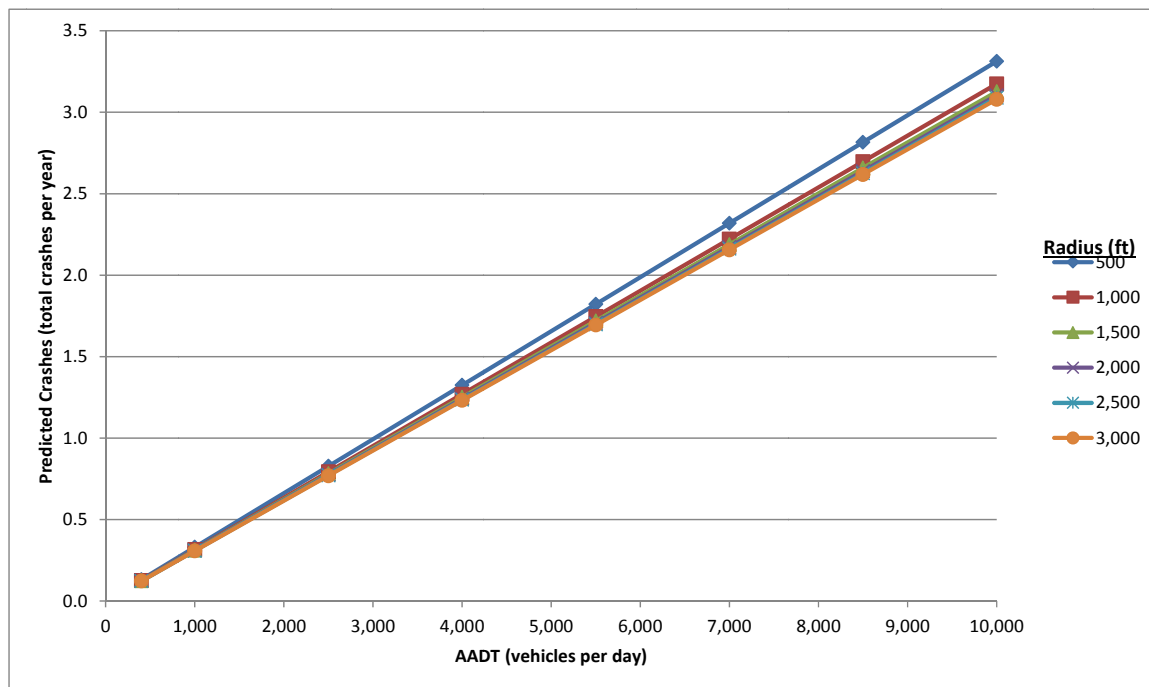

Figure C- 2. Annual Predicted Crash Frequency by Radius for a 15° Deflection Angle

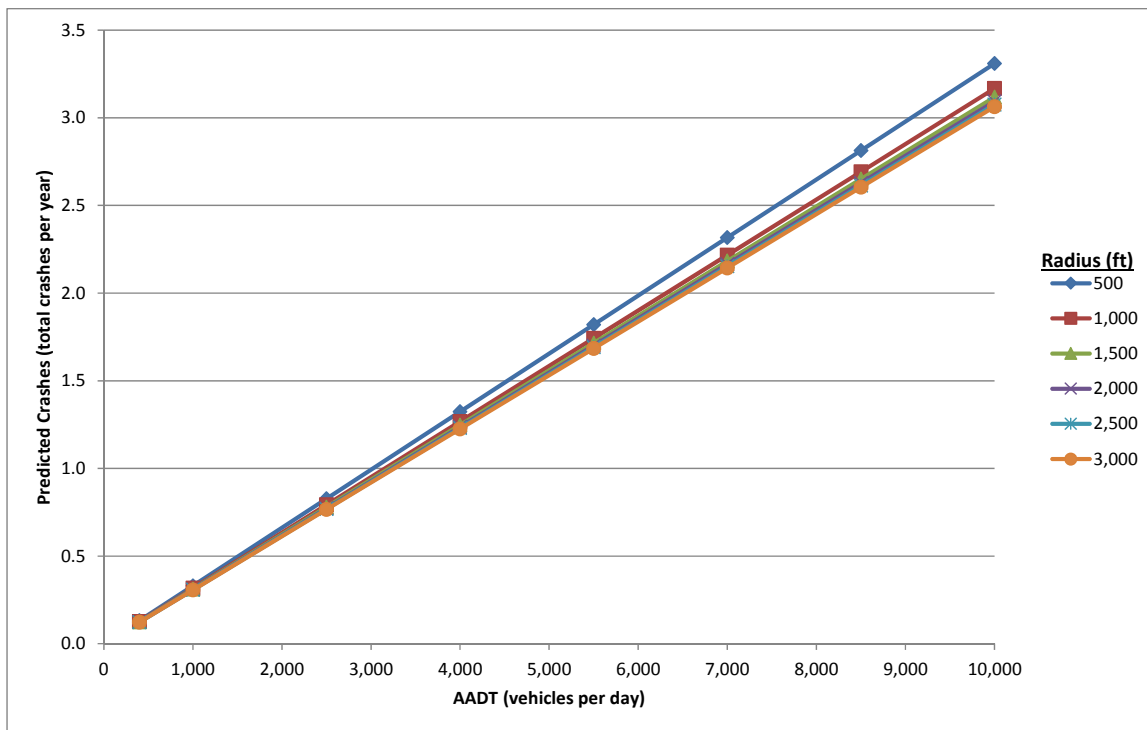

Figure C-3. Annual Predicted Crash Frequency by Radius for a 30° Deflection Angle

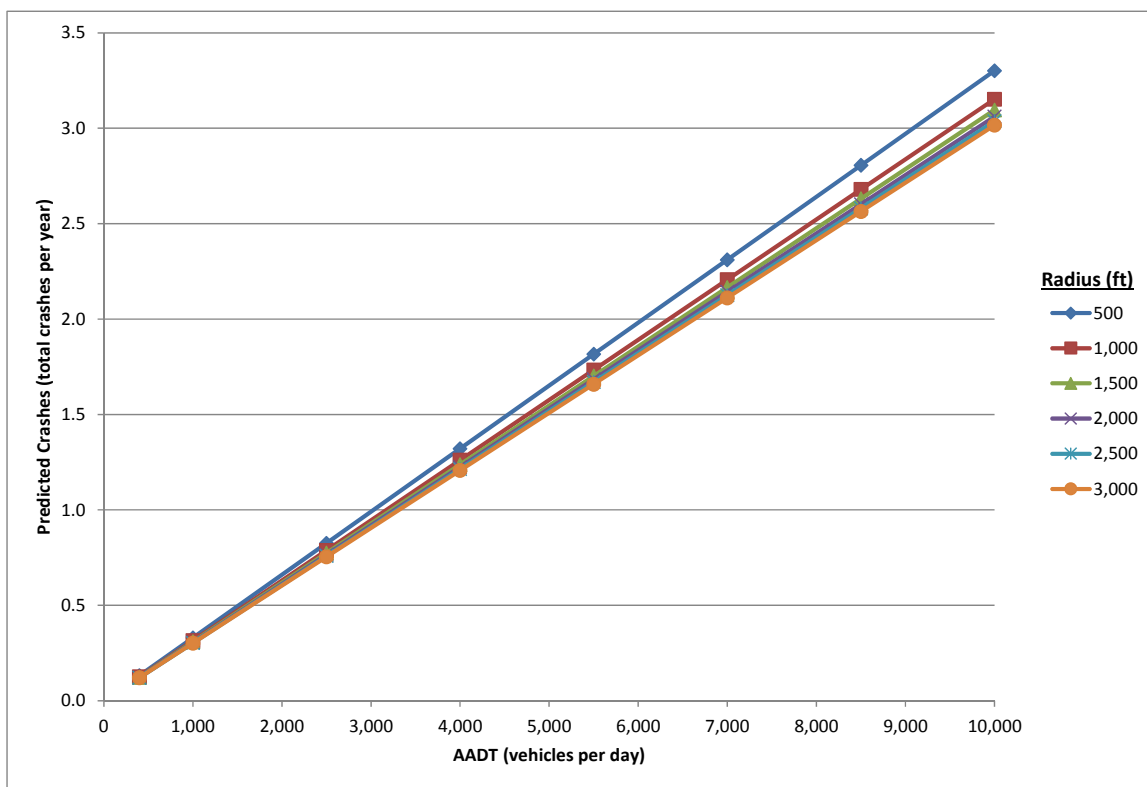

Figure C-4. Annual Predicted Crash Frequency by Radius for a 45° Deflection Angle

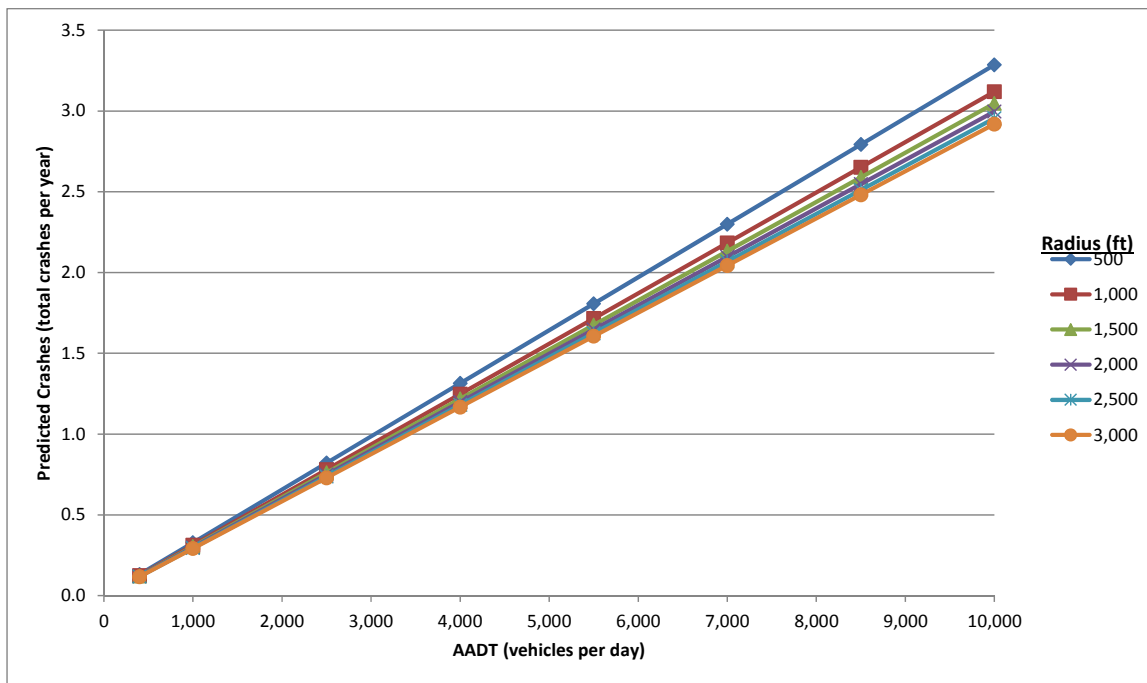

Figure C- 5. Annual Predicted Crash Frequency by Radius for a 60° Deflection Angle

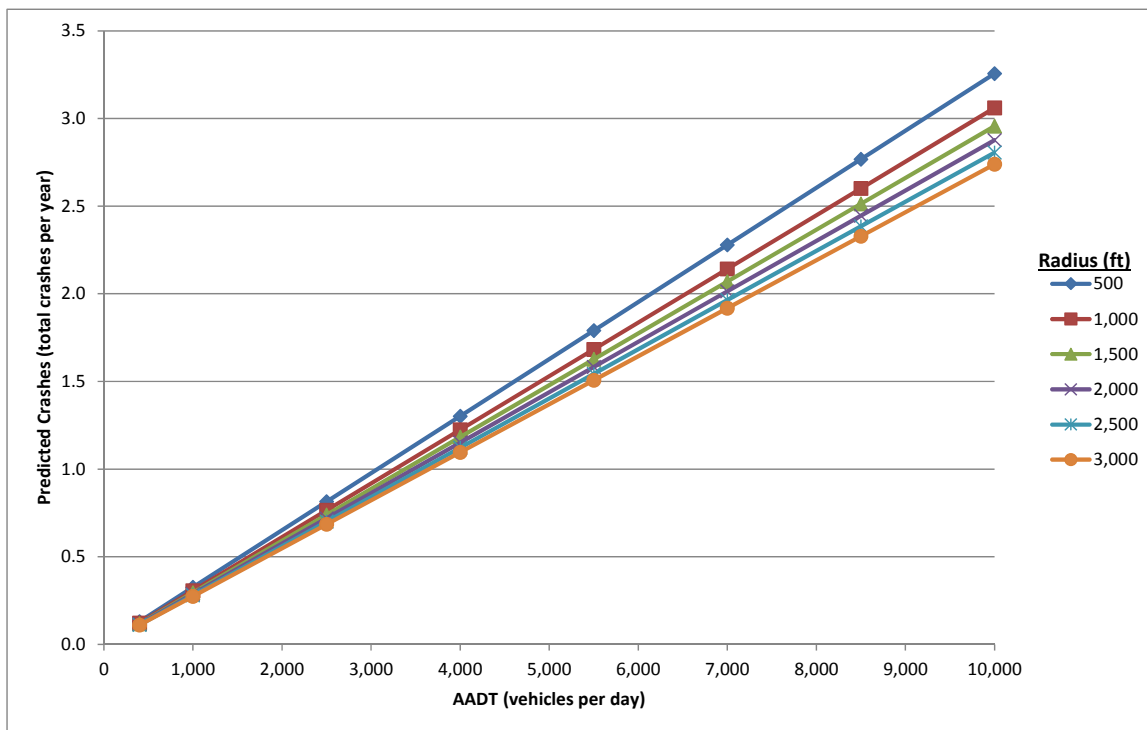

Figure C- 6. Annual Predicted Crash Frequency by Radius for a 75° Deflection Angle

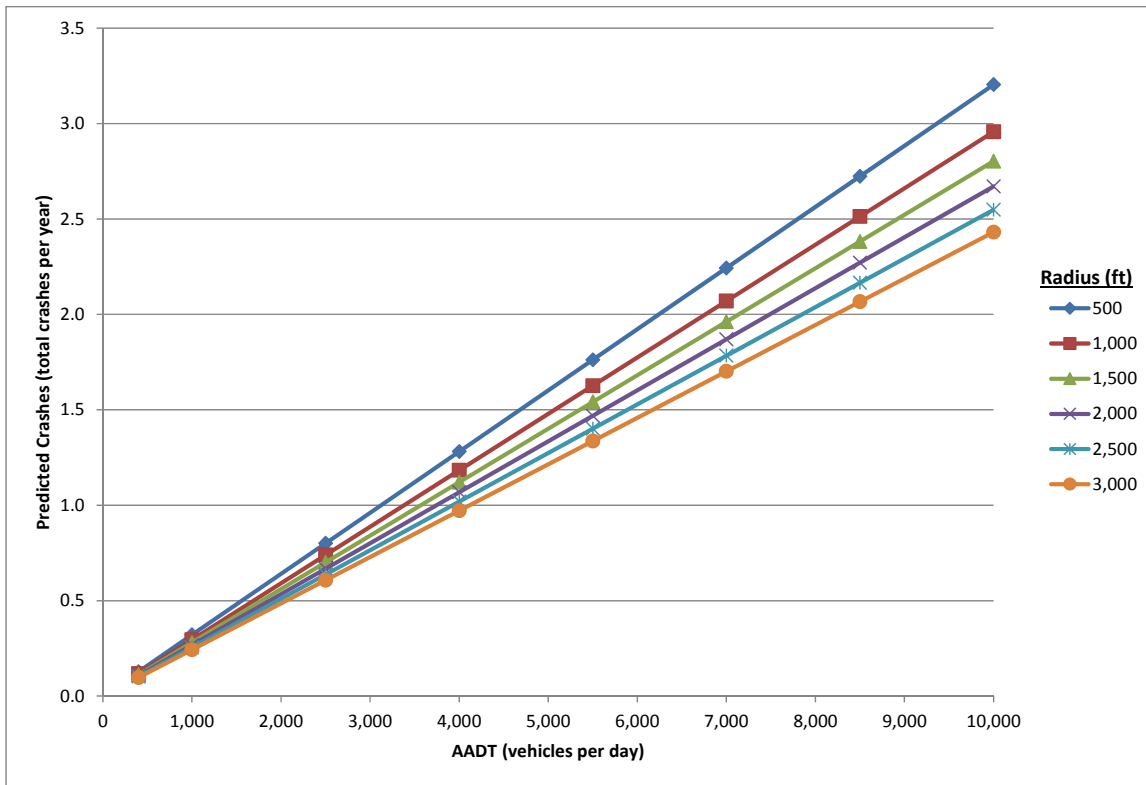

Figure C- 7. Annual Predicted Crash Frequency by Radius for a 90° Deflection Angle

Table C- 2. Predicted Annual Crashes for Ranges of Traffic Volume and Varying Combinations of Radius and Central Angle

Radius of Curve	Predicted Annual Crashes for Central Angle of 45 degrees		
	4000 vpd	7000 vpd	10,000 vpd
500	1.321	2.311	3.302
1000	1.261	2.207	3.153
1500	1.238	2.167	3.096
2000	1.225	2.143	3.062
2500	1.215	2.126	3.037
3000	1.207	2.112	3.017

For the purposes of considering safety performance as a basis for curve design policy, the following is evident:

- For lower volume curves, the predicted crashes vary only slightly if at all both for differing radii and a common central angle, or differing central angles and the same radius.
- As volumes increase (say, to 4000 vpd or greater) the differences become meaningful.
- As the relationships among radius, central angle and length of curve are non-linear, the changes in crash prediction, and differences between radii for the same central angle, are non-linear.

Table C- 3. Predicted Changes in Annual Crashes for Changes in Radius (from Table C-2)

Change in Radius of Curve	Predicted Reduction in Crashes for Central Angle of 45 degrees		
	4000 vpd	7000 vpd	10,000 vpd
500 to 1000	0.06	0.104	0.149
500 to 1500	0.083	0.144	0.206
500 to 2000	0.096	0.168	0.24
1000 to 2000	0.036	0.064	0.091
1000 to 3000	0.054	0.095	0.136

From the perspective of design policy, any predicted crash reduction greater than 0.02 is meaningful for the purposes of cost-effectiveness analysis. Even for traffic volumes as low as 4000 vpd, a change from 500 to 1000 foot radius (0.06) translates to one crash every 16 years. Depending on the severity profile, this may translate to a meaningful valuation.

Finally, in the context of a longer service life, which is proposed in the Interim Report, differences in safety performance become even more meaningful. Table B4 shows the differences based on the annual crash reductions from Table B3, multiplied by 50 based on an assumed 50-year service life (and assuming no change in traffic volume).

Table C- 4. Total Predicted Crash Reductions from Table B2 for a 50-year Service Life

Change in Radius of Curve	Predicted Reduction in Crashes for Central Angle of 45 degrees		
	4000 vpd	7000 vpd	10,000 vpd
500 to 1000	3	5.2	7.45
500 to 1500	4.15	7.2	10.3
500 to 2000	4.8	8.4	12
1000 to 2000	1.8	3.2	4.55
1000 to 3000	2.7	4.75	6.8

The implications and value of applying predictive models to formulation of design policy for both new roads and existing roads are clear. A useful approach could further expand the analysis to illustrate safety effects assuming differing base conditions that would be consistent with differing contexts (e.g., narrower lanes and/or shoulders that would be designed in mountainous terrain, including effects of grade, illustrating effects of spiral usage, etc.). Also, individual state models or calibration factors may produce important, different crash reduction values. In any event, this analysis demonstrates the importance of including traffic volume in some manner in horizontal curvature design policy. Even at a very general level, one can conclude that variance in allowable curvature is much less critical for lower volume roads, and in fact may not be critical at all for volumes less than, say, 1000 vpd (as the ongoing effort on Very Low Volume Road criteria is demonstrating).

Crash reductions can be translated to user benefits in dollar terms, applying an agency's crash costs and adjusting for crash severity. (For existing roads being reconstructed, an Empirical Bayes' approach that combines predicted with actual crash history would be used, thus incorporating the specific context of the site.) To illustrate the order of magnitude of crash reductions, one could apply an approximate value of \$100,000 per curve crash, in which case the dollar benefits over a 50 year life would range from \$200,000 for lower volume, moderate curvature to

\$1,200,000 for higher volume, sharper curvature (per values in Table B4). And, as previously noted, crash reductions could be greater for other contexts.

## Operational Implications

The geometry of alignment also produces small but potentially meaningful operational effects that are worthy of further investigation. As described above, for any given central angle the combination of curvature and tangent length produces varying total alignment length. Table B5 illustrates the magnitude of the differences in length associated with the range of radii for 45 and 75 degree central angles.

Table C- 5. Effect of Horizontal Curve Geometry on Travel Distance

Radius of Curve	Travel Distance for Range of Alignments					
	45 degree Central Angle			75 degree Central Angle		
	Length of Curve	Lengths of Tangents	Total Travel Distance	Length of Curve	Lengths of Tangents	Total Travel Distance
500	0.0744	1.058	<b>1.132</b>	0.124	0.991	<b>1.115</b>
1000	0.1487	0.979	<b>1.128</b>	0.2479	0.846	<b>1.094</b>
1500	0.2231	0.901	<b>1.124</b>	0.3719	0.7	<b>1.072</b>
2000	0.2975	0.823	<b>1.12</b>	0.4958	0.555	<b>1.051</b>
2500	0.3719	0.744	<b>1.116</b>	0.6198	0.41	<b>1.03</b>
3000	0.4462	0.666	<b>1.112</b>	0.7437	0.264	<b>1.008</b>

Flattening a 45 degree central angle curve from 500 foot radius to 3000 foot shortens the alignment length by 0.02 miles. For the 75 degree central angle, the difference is even greater – 0.107 miles.

Although these length reductions appear small, when translated to traffic over a year, the reductions in total travel as measured by VMT can become significant, particularly for volumes above 7000 vpd (Table B6).

Finally, even small reductions in travel distance can produce meaningful aggregate operating cost savings, particularly for higher volume roads, and when computed over a longer service life. Table B7 illustrates the savings taken from multiplying the VMT values in Table B6 by the \$0.61 per mile operating cost cited in the Interim Report (from AASHTO) and computed over a 50 year service life. (Note that in most cases, alignment length changes will be on the order of 0.03 miles or less. Based on this analysis, one should expect that the life cycle operational benefits of curve flattening will be on the order of \$1.0 to \$3.0 million for typical design decisions and moderate to higher volumes.

The values in Table B7 would be inputs to a cost-effectiveness design policy, and/or a design process for existing curves. Other influencing factors include the effect of the curve on speeds, and traffic distribution including specifically trucks. From the perspective of developing a more cost-effective design policy for curvature, both the crash and operating cost implications of curve geometry are compelling. The complex relationships of curve geometry, other design factors cited previously, and cost effects attributable to context variance all bear further study. As a minimum, the findings reinforce the recommendation that traffic volume be a direct input or factor in the formulation of curve design policy.

Table C- 6. Annual Reduction in Vehicle Miles of Travel for each 0.01 mile Reduction in Travel Distance

Change in Alignment Length (miles)	Annual Reduction in Vehicle Miles of Travel for Range of Average Daily Traffic Volumes			
	4000	7000	10000	17000
0.01	14600	25550	36500	62050
0.02	29200	51100	73000	124100
0.03	43800	76650	109500	186150
0.04	58400	102200	146000	248200
0.05	73000	127750	182500	310250

Table C- 7. Total Vehicle Operating Cost Savings for 50 Year Project Life for Reductions in Travel Distance.

Change in Alignment Length (miles)	Total Savings in Vehicle Operating Costs for Reductions in VMT for 50 Year Service Life at \$0.61 per mile			
	4000	7000	10000	17000
0.01	\$ 445,300	\$ 779,275	\$ 1,113,250	\$ 1,892,525
0.02	\$ 890,600	\$ 1,558,550	\$ 2,226,500	\$ 3,785,050
0.03	\$ 1,335,900	\$ 2,337,825	\$ 3,339,750	\$ 5,677,575
0.04	\$ 1,781,200	\$ 3,117,100	\$ 4,453,000	\$ 7,570,100
0.05	\$ 2,226,500	\$ 3,896,375	\$ 5,566,250	\$ 9,462,625

## Appendix D: Operations and Maintenance Considerations for Geometric design



## Operations and Maintenance Considerations for Geometric design

This Section identifies the typical decisions that could be made during the highway geometric design process and make significant impacts on Operations and Maintenance (O&M) cost and the lifecycle efficiency of the roadway infrastructure. Examples of the typical design options for consideration during the design process are also highlighted and the liabilities associated with the designer's options are discussed. A conceptual framework for incorporating O&M considerations into the geometric design process is described with suggestions for future research. This framework is intended for use and development by designers to suit their specific project or program needs.

### Introduction

O&M often carries a number of definitions. Within this Chapter the following definitions apply:

- Operations - operations activities respond to the facility objectives, including providing mobility, travel time reliability, safety and security for the road users, and the on-site maintenance/construction crew. Examples of activities include traffic incident management and work zone management. For the purposes of this section, geometric design refers to all the aspects of the operations of highway activities including determining the length of work zones per each phase of construction.
- Maintenance – routine and periodic maintenance activities including pavement resurfacing that are conducted to allow for the safe and efficient operation and use of the highway. Examples of routine maintenance activities include debris removal, mowing, snow removal, pavement patching or crack repair and drainage clearing. Examples of periodic maintenance include replacement of pavement joints, overlay or guardrail replacement. Whether designing new highways or implementing improvements or other changes to existing highways, it is important to consider the impact of design decisions on the ease, frequency and cost of future maintenance that the design will have. A project that is hard-to-maintain may become unattractive and cease to serve its intended operational purpose due to maintenance difficulties. The geometric designer's objective should be to provide a design that is fit for purpose, while keeping the future maintenance liability to a minimum.

### Consideration of Operations and Maintenance during Geometric Design

Currently, in a typical project development effort, only the capital costs of a project are considered as part of the project development. In a few cases, the feasibility of future maintenance may be considered, but the cost of future maintenance is typically not. The concept of closing a lane/s for incident management, street sweeping, tree trimming, or maintenance of the ditch are not among the typical design decisions considered by the designers. It is important to consider future maintenance costs & activities during the planning/design stage of any significant infrastructure investment, including a highway project, as decisions made early in the lifecycle can have a material impact on future maintenance costs.

In addition, the safety performance of the operations should be better understood and informed decisions should be made in implementing the improvement. Therefore, consideration during the design process of how a highway is to be maintained is beneficial to the owner with future responsibility for maintenance costs and provides assurance that the system can be maintained as designed.

Finally, failure to adequately consider O&M during design may increase the risk of future liability. As noted previously, maintenance functions are ministerial in nature and subject to tort claims if not carried out properly or within a reasonable time. Consider, for example, the geometric design of a curve that drains poorly, and which has guardrail along the edge of shoulder. If run-off-road crashes occur with great frequency involving vehicles striking the guardrail, the owning agency will suffer great pressures (in addition to high costs) to continually repair and replace the guardrail. Failure to do so in a timely manner may produce tort liability risk if a driver strikes a section of guardrail that is unrepaired and hence not functioning as intended.

If O&M is not considered at each stage of the design process there is the potential that additional mitigation measures will be required during later stages of the project lifecycle, often at disproportionate additional cost, or that the design may need to be reworked. The following summarizes the key reasons for the incorporation of

operations and maintenance considerations in the geometric design process (Roads in Hertfordshire: Highway Design Guide 3rd Edition, Section 2: Highway Layout and Strategies, Chapter 7: Design for Maintenance):

- Effectiveness – A project that is inexpensive and simple to maintain is much more likely to be maintained, meaning that the project will stay in good condition for much longer and continue to fulfil its purpose.
- Cost – There are limited resources for construction and maintenance. Future maintenance liabilities can be eliminated or reduced through careful and effective design. To minimize costs, consideration should be given to whole life-cycle costs, including design, construction, operation and maintenance.
- Disruption – Frequent maintenance is disruptive to communities and road users. Assets that are easy to maintain will help to minimize disruptions. This translates into better service provision. Designing with maintenance in mind leads to an asset that needs less work to remain in good operating condition.
- Responsibility – At a limited number of locations, facilities on the same right of way and/or structures are operated and maintained by different entities. Example: a County Road over a freeway in which the County owns the roadway but the bridge belongs to the state DOT; also the signal operation at the ramp terminal intersections with the county road. In this case, the overall design must consider access issues for both parties as well as facilitate agreed to O&M protocols.
- Environment – Maintenance work has an associated carbon footprint, whether resulting from the vehicles and equipment used to cut grass or clean drains, or from the energy and raw materials used in producing, transporting and laying asphalt. Reducing the need and frequency of future maintenance will help to reduce the impact on the environment.

An important consideration that geometric designers should consider is ease of maintenance or access. If difficult, there will be greater traffic management costs and greater potential risk to maintenance workers. The designer needs to consider how the need for maintenance can be either avoided or minimized and where it is required, how maintenance can be made easier and safer. This is best done by involving experienced maintenance staff throughout the geometric design process, and especially early in the process when right-of-way and alignment and cross section dimensions are being set.

### **When Should Operations and Maintenance Be Considered during the Geometric Design Process**

O&M should be considered at the time of developing project alternatives, including fundamental issues surrounding route choice and purpose. Organizations responsible for future maintenance should be consulted at the earliest opportunity and then at regular intervals throughout the design/planning process.

Improvements to the safety and efficiency of maintenance operations can be introduced at any stage of the design process, but with varying degrees of potential impact and cost. The greatest scope for providing improvements in safety is during project preparation; particularly on projects where additional ROW is required.

Depending on the type of project improvement, stakeholder workshop sessions could be initiated at the start of the project development process (and continued throughout as necessary) as they will allow significant or unusual hazards to be identified and either eliminated or any remaining residual hazards to be mitigated, at minimum cost and disruption to the design. Carrying out design reviews at key stages of the design process is an appropriate means of ensuring that progress is made in the management of risk, and that any strategy is monitored throughout the design phase. Typical projects developed under Context Sensitive Solutions (CSS) policies require that the stakeholders be engaged in the design development.

Regardless of project type and context, every project requires the designer to assess and manage tradeoffs among important variables of interest to stakeholders and the owning agency. Risks can be identified and communicated to others at every stage of the process.

The Design Manual issued by the Washington State Department of Transportation dedicates a major section (Chapter 301) to discussing the best practices to improve coordination between designers and maintenance personnel during the project design stage. One of the suggestions is to develop tangible maintenance performance

measures to help designers evaluate design alternatives. The WSDOT Design Manual also emphasizes the importance of considering the full lifecycle cost for maintaining certain roadway features. A Life Cycle Cost Analysis (LCCA) to quantify the maintenance and operation cost of design alternatives is a very powerful tool to help designers justify the final asset decision. The WSDOT Design Manual provides an example of a Design Option Worksheet, used to show how a Life Cycle Cost Assessment can be used to determine the optimum solution to address a design for maintenance issue (reference, Exhibit 301-2 Design Option Worksheet Showing Example of Life Cycle Cost Assessment – example page 136). Although this is for the re-design of a section causing maintenance access problems, it shows a) the issues caused through failure to consider maintenance needs during design and b) an approach to use in assessing the design alternatives.

## **Can Operations and Maintenance Considerations Incorporated within the Geometric Design Process**

The consideration of O&M can be seen as a discrete overlay that can sit atop of other design decisions, and each decision can be evaluated through the use of LCCA models and cost-benefit analysis (CBA) approaches that are common within the industry. It can be summarized in the form of a Maintenance and Repair Strategy Statement<sup>11</sup>, or similar, and in this way, design decisions can be documented for future reference and for reconsideration in the future as required.

When designing the geometry of new highways, it is important for designers to consider the impact that the design will have on future maintenance and operation requirements. Communication between designer and maintenance engineer throughout the design process is crucial, such that the geometric design can be adjusted to improve road safety and to minimize the future maintenance frequency and cost. There may be challenges in the coordination process, as proposed designs may need new/different O&M practices.

### *Tool development*

Although maintainability is part of the evaluation process during highway design, the focus of the design process is always towards the construction aspects. Whole life-cycle cost analysis, which includes both construction cost and maintenance/rehabilitation cost is often neglected or addressed qualitatively. To understand different design parameters and their impact on the future maintenance cost, it is essential to develop a quantitative model of the average maintenance costs of specific geometric designs.

Operations and Maintenance considerations for highway design are frequently mentioned in DOT design manuals (see, for example, the Connecticut, Texas and Virginia DOT design manuals). However, the O&M advice provided in manuals is typically qualitative. Designers need quantitative information on the impacts of their decisions. The FHWA LCCA tool provides an interactive way to do this for pavement design applications and serves an example of the type of model that is needed for O&M cost applications.

FHWA LCCA software<sup>12</sup> allows designers to perform LCCA for pavement selection in accordance with FHWA design methods. The LCCA model requires many project level input parameters such as hourly traffic

---

<sup>11</sup> CIRIA Report C686 “Safe Access for Maintenance and Repair. Guidance for designers 2nd edition 2009  
<http://apps.trb.org/cmsfeed/TRBNetProjectDisplay.asp?ProjectID=373>

<sup>12</sup> FHWA LCCA model - <https://www.fhwa.dot.gov/infrastructure/asstmgmt/lccasoft.cfm>

Interim Advice Note 69/15, Designing For Maintenance (April 2015), Highways England Roads in Hertfordshire: Highway Design Guide 3rd Edition, Section 2: Highway Layout and Strategies, Chapter 7: Design for Maintenance

Maintenance Considerations in Highway Design, Road Engineering Journal, Copyright © 1997 by TranSafety, Inc.

National Highway Research Program (NCHRP) Project 14-9 (2) and NCHRP Report 349 "Maintenance Considerations in Highway Design"

The Institute of Asset Management, Asset Management – an anatomy, Version 2, July 2014, [www.theiam.org](http://www.theiam.org)

Washington State Department of Transportation, Design Manual M 22-01.11, July 2014

distribution, vehicle stopping costs, road user cost, maintenance work zone assumptions, etc. The model is also able to perform risk analysis based on user-defined probability functions.

Developing a maintenance cost model, similar to the FHWA LCCA model, will help designers and maintenance personnel to understand the incremental maintenance costs of different geometric design alternatives. In particular, the model should address the geometry of roadway elements such as shoulder width, maintenance access, roadside slope, etc. It is suggested that the lifecycle model inputs could be divided into three categories, project level inputs, geometric design, and cost inputs. These categories are described in the following sections and tables:

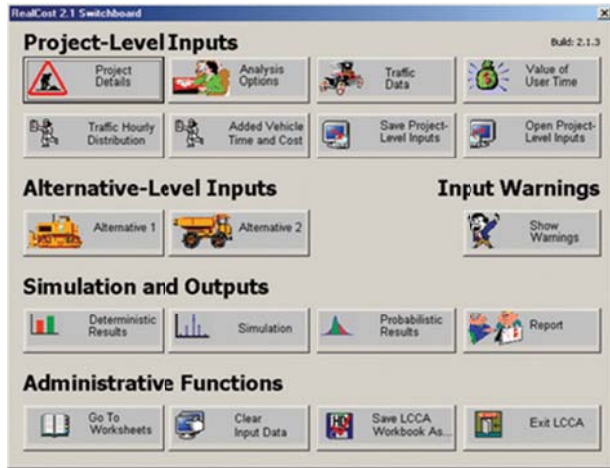

Figure D-1. Example of LCCA model from FHWA - RealCost 2.1 Switchboard

**Project Level Inputs:** Project level inputs are pieces of information that apply to all geometric design alternatives.

**Table D-1 Project level inputs.**

Input	Notes
Project details	To identify the design alternative. It is not going to affect the analysis results
Analysis period	Number of years that the design alternatives will be compared
Discount rate	To calculate present value
AADT	Annual average daily traffic of design year
Traffic Growth Rate	The percentage growth rate of AADT
Rural or Urban Traffic	User cost is higher in urban roadway
User cost	Value of user time for different vehicle types
Crash cost	Crash cost estimates such as minor, serious or fatal accident

**Geometric design Inputs:** This part of the model requires the input of different design alternatives. Users can select up to a certain number of roadway elements to compare their lifecycle cost.

**Table D-2 Geometric design inputs.**

<b>Input</b>	<b>Notes</b>
Access	Size/number of access points for routine maintenance
Vertical alignment	Key design parameters descriptions including items such as maximum grade
Horizontal alignment	Key design parameters descriptions including items such as minimum curve radius
Cross Slope	
Drainage	Drainage design description and design parameters
Intersection	Type of intersection, such as stop, signalized and roundabout
Lane	Number and width of traffic lane
Lateral Offset	Width
Median	Width
Right of Way	Area
Shoulder	Width
Roadside Slope	Gradient

**Table D-3 Cost inputs**

<b>Input</b>	<b>Notes</b>
Construction Cost	Total construction cost of the project
Maintenance Frequency	Different design alternative might require maintenance frequency. For example, pavement built at mountainous terrain requires more frequent maintenance than pavement at level terrain.
Maintenance Cost	Total maintenance cost in base year
Work zone hours	Total work zone hours for the maintenance operations
Crash Societal Costs	Developed from the predicted crash frequency methodologies

**Results and Reports:** Based on the above three category inputs, analyses could be conducted to meet the objectives of the project development and provide the decision makers comprehensive life-cycle costs based on considerations beyond the typical capital construction costs alone. Some default reports could be developed to compare the results of different alternatives. With further development, the maintenance model can be a powerful tool to optimize the life-cycle cost of a highway design.

## Geometric Design Options

The design profession needs a robust and complete knowledge base and toolkit that relates geometric design elements and decisions to the full range of O&M activities. Such a toolkit is beyond the scope of this project; but to advance the thinking in this field the following qualitative guidance is offered. Table 4 provides a list of sample potential design options with consideration to the individual design elements. This table was assembled by the research team, supplemented by experts in road maintenance and operation. Initial and general ratings are provided for the estimated impacts on the geometric options in four basic areas: of

- Capital costs – costs of initial construction
- Lifecycle efficiency – efficiency of operations and maintenance after construction over the lifecycle of the asset
- Maintenance safety – safety of maintenance workers
- Owner liability – risk to owner including claims, reputation and other costs, direct and indirect outside of operations and maintenance

Several examples of the potential geometric design decisions and the rating of the associated category are provided in three basic categories:

1. Horizontal/Vertical alignment.
2. Cross-Section elements.
3. Roadside design

These are the categories of items that were identified to have a predominant effect on the lifecycle maintenance activities, and the items/potential pitfalls of the typical geometric design. These examples/categories can be further developed to make a comprehensive list and a detailed level to address the overall project's O&M, or could be developed at individual project type such as 3R, New Construction, and Reconstruction categories; in addition to the category of the facility types. In addition to the standard design criteria, these O&M related design options could be used in the design development process.

**Table D-4 Examples of Geometric Design Decisions**

↓	Increased liability, cost / reduced safety
↕	May increase or reduce criteria
↑	Reduced liability, cost / increased safety

Categories assigned are indicative only and will need to be assessed for each overall design.

Design Element	Geometric Design Options	Capital Cost	Lifecycle Efficiency	Maintenance Safety	Owner Liability	Examples
<b>Horizontal / Vertical Alignment</b>						
Horizontal Alignment	Avoid sharp horizontal curvature (small radii) which may incur more maintenance from loss of surface friction, poor drainage, from melting snow and run-off-road crashes. Where sharp curvature is unavoidable, consider wider lanes, paved shoulders, and speed reduction measures in advance of the curve.					.. Address issues of pavement rutting and polishing that might affect drainage. Curves also require more signage and other appurtenances. Consider future tort liability if there is a maintenance issue.
Stopping Sight Distance	Increase sight distance on approach to features needing frequent or regular maintenance (bridges and culverts, intersections with traffic control devices)					Consider increased sight distance by bridge areas to accommodate annual or routine bridge maintenance.
Vertical Alignment	Avoid placement of features needing regular maintenance beyond the crest of a curve. If this is unavoidable, provide additional shoulder width or pull-off area.					Additional shoulder width or pull-off area can be used for safe parking of maintenance vehicles.
	Avoid sag vertical curvature in superelevation transition areas or with limited cross slope. Cross slope, superelevation and vertical curvature can combine to have difficult to understand					Combination of design elements may cause water ponding and poor subsurface drainage, both of which can damage the pavement. Geometric design should incorporate the checking

	effects.					of pavement contours prior to finalizing the three dimensional alignment.
Drainage	Develop and refine vertical and horizontal alignments of culverts so that inlets and outlets are close to existing channels					Helps to prevent sediment or erosion. Consider future pavement resurfacing requirements when establishing vertical clearances and designing elements such as inlet grates and manhole covers.
Other	Investigate geology and geotechnical features to avoid or minimize potential maintenance problems					Investigate rock slides, highly erosive or expansive soils, unsuitable materials.
	Maximize southern exposure in mountainous and hilly areas and allow space with proper drainage for dumping or storing plowed snow					Southern exposure minimizes snow and ice accumulation.
<b>Cross Section</b>						
Traveled Way	Widen pavement 2 to 3 feet to reduce edge stress					Consider also shoulders tied into travel lane pavement.
Shoulder	Provide at least 12-foot shoulders for maintenance vehicles to operate without affecting traffic. Where narrower shoulders are necessary, provide intermediate wider turnout locations.					Reduces access costs and provides safe access. Assess width of ROW versus steeper slopes or retaining wall.
	Provide alternative access routes to avoid need to use lane or shoulder					Provide longitudinal sidewalks/shared used pathways between features to allow safe access.
	Provide pull-off areas for maintenance vehicles where full shoulders are not present					Make provision on roads without any existing shoulder or designed pull-off area. Provide paved areas adjacent to shoulders, particularly for frequently maintained features e.g. signal controllers at intersections.



Drainage	Consider alternative drainage designs					Avoid manhole covers within lanes and shoulders
Median	Median openings for barrier or closed medians					Improves maintenance access, but may present other issues such as the need for barriers and signage to prevent driver abuse.
	Use a movable barrier to provide access					Improves maintenance access, but may present other issues.
	Increase width					Provide wider medians to eliminate the need for glare screens and to reduce their construction and maintenance costs.
	Improve maintenance worker access to median. Improve maintenance access and safety where necessary to be narrow.					Avoid the use of unpaved narrow medians as maintaining grass areas is difficult, and costly. Use concrete median barriers in narrow medians to redirect vehicles parallel to the traveled way.
Median	Minimize features in medians					Avoid manholes in shoulders and medians
Lateral Offset	Move work to locations remote from traffic					Place cabinets near right-of-way line
Side Slope	Provide benches in higher cut slopes					Collect debris, slow runoff, and collect water from slope pipes. Access for maintenance vehicles should be provided.
	Reduce roadway side slope ratios and ditch profile grades. Flatten side slope embankments.					Minimizes erosion potential and makes maintenance operations easier. Conduct an engineering analysis to compare embankment sections having flat slopes and wider right-of-way with sections having steeper slopes or retaining walls, or both.
Drainage	Design roads with ditch shapes that can					Ditch bottoms should be wide enough

	be maintained					to be maintained with common grading equipment
Sound Walls	Provide doors in the wall to access from behind					
<b>Roadside Design</b>						
Access	Avoid access locations where lane departures are more likely when locating features requiring regular maintenanceroadside appurtenances.					Avoid locating a cabinet or sign at end of lane merge tapers or at narrow shoulders
	Provide alternative access routes to avoid need for maintenance vehicles to close a lane or shoulder					Provide cut-throughs at interchanges and small lengths of gated access road.
	Provide pull-off areas for maintenance vehicles					Locate pull-off areas adjacent to features to be maintained
	Reduce the amount of hand trimming required and eliminate places that are difficult for mower access					Select low maintenance and low growth landscape features
Clear Zone	Avoid obstructions within the clear zone					Placement of appurtenances away from the traveled way, especially in areas on the outside of curves.
Lateral Offset	Location of signage					Move sign positions away from trees or vice versa. Remove trees in advance of signs to avoid the need for continual trimming
	Place lighting columns on bridge approaches					Consider placing lighting columns on approaches to bridges rather than on the bridge to remove the need to access them from the bridge itself
	Minimize features on the roadside within complex highway geometry					Increase distance of the roadside features to traffic within a complex interchange.
	Provide inlets in grass medians and in curbed sections					Eliminates ponding. Combine inlets with curb openings if debris accumulation is a problem.

	Co-locate features at locations where maintenance is safe and convenient					Weather stations, control and power cabinets combine concrete barrier, glarescreen, lighting base, drainage.
	Place roadside appurtenances to optimize maintenance access					Move away from the roadway. Reduces need for barriers and guardrails
	Locate signs so that guardrail requirements are minimized					Ensure access is easily and safely available, visibility is not inhibited, conflict with landscaping and other highway elements is avoided, and vegetation control operations are not hampered.
Lateral Offset	Avoid placing signs in the ditch					This might impede drainage, make mowing more difficult and result in erosion or siltation around the sign support. Consider riprap around sign supports to minimize the need for herbicidal treatment.
Fixed Objects	Avoid the use of roadside barriers if the fixed object can be appropriately relocated or eliminated					Roadside fixed objects should only be used where alternatives are impractical.

## Key Geometric Design Options Discussion

There are a number of key decisions required during the geometric design process that are included in the previous table. This section explores the options in more detail and proposes an overall approach that would serve to assist in geometric design process communications and post-design requirements.

### 8.6.1 O&M Strategic Plan

It is recommended that a holistic approach be used from the outset of design that draws together inputs from the designer and experienced maintenance personnel in the form of an O&M Strategic Plan. The O&M Strategic Plan documents the O&M design decisions made throughout the design process, with an approach that assesses, at each design process step, whether the overall design facilitates future O&M activities.

**Table D-5 O&M Strategic Plan Development during Geometric Design Process**

<b>Step 1</b>	Define the Transportation Problem or Need	<i>Preliminary risk assessment and decisions regarding alignment</i>
<b>Step 2</b>	Identify and Charter all Project Stakeholders	<i>Identify stakeholders for O&amp;M Strategic Plan input</i>
<b>Step 3</b>	Develop the project Scope	<i>Accounts for key project O&amp;M risks</i>
<b>Step 4</b>	Determine the Project Type and Design Development Parameters	
<b>Step 5</b>	Establish the Project's Context and Geometric Design Framework - Project Evaluation Criteria	<i>Establishes basis for O&amp;M geometric design options</i>
<b>Step 6</b>	Apply the Geometric Design Process and Criteria	<i>Make and document assessments of O&amp;M geometric design alternatives using CBA, LCCA and other methodologies in order to make informed tradeoffs</i>
<b>Step 7</b>	Designing the Geometric Alternatives	<i>Review the overall project risks and select the most appropriate geometric alternative</i>
<b>Step 8</b>	Design Decision-making and Documentation	<i>Continue to refine the design to and document assessments and tradeoffs, guided by risk assessments</i>
<b>Step 9</b>	Transitioning to Preliminary and Final Engineering	
<b>Step 10</b>	Agency Operations and Maintenance Database Assembly	<i>Production of final O&amp;M Strategic Plan</i>
<b>Step 11</b>	Continuous Monitoring and Feedback to Agency Processes and Database	<i>Re-use the approaches for similar projects and incorporate feedback from O&amp;M staff</i>

Producing an O&M Strategic Plan requires effective communications throughout the design process and beyond only the geometric design. It is a document that, from the outset of a project, can inform the production of an asset management plan for the facility and help to address legislative requirements, e.g. MAP-21.

#### *NCHRP Report 349*

The recommendation concerning O&M analysis and strategic planning compliment the findings of NCHRP Report 349. This NCHRP report recommends that maintenance be considered from the commencement of initial location studies, and that this consideration should be continued throughout the design process. Decisions regarding alignment have a substantial impact on O&M requirements and are some of the earliest decisions that need to be made. The number of intersections or interchanges along a route, or the decision that the route should go around an obstacle, under it, or over it has profound capital, O&M cost and safety implications. The costs for the construction, maintenance and operation each choice of route, and associated worker risks should be assessed using similar parameters. This can be applied across locations and different types of facility.

## 8.6.2 Use of ITS

The use of intelligent transportation systems (ITS) requires a major commitment by agencies to provide the necessary resources to safely and efficiently operate a highway. Increasingly in urban areas it is often the only way by which to make expansions or new construction feasible to provide the necessary capacity. Additional considerations are needed regarding potential operational failure, and risk e.g. during a power outage.

### *Roadside geometry versus roadside alternatives*

Roadside appurtenances also demand a large share of maintenance budget. Traffic, vandalism, animals, and atmospheric conditions can cause damage to these elements. Their maintenance and repair are labor-intensive. Substantial cost can be saved if they are designed and built to be safe, durable, and easy to maintain.

Maintenance problems related to drainage are costly expenditures. Constant attention must be given to controlling erosion in ditches, cleaning culverts and stormwater systems, repairing eroded and scoured outlet areas, controlling corrosion, and repairing damage due to frost and clogging.

One of the principal tradeoffs will be the decision about the costs and benefits of the alternative designs that reduce right of way and land acquisition costs by incorporating steeper slopes, walls or require more physical barriers. The amount of right-of-way needed should reflect the analysis of what might be considered that needed for a least cost maintenance design. The use of decision making tools and development of a lifecycle cost model will assist to design decision-making. There may be specific concerns that preclude some options, but an overall assessment, including a cost benefit analysis (CBA) can assess design alternatives and inform the process.

### *Owner Liability*

Operations and maintenance is a DOT function and a responsibility that only increases with an expanding network. With any increase in maintenance needs comes an increase in liability for the responsible agency. To reduce this liability, designs with reduced or low maintenance and limited worker exposure should be the ultimate goal. In addition to a maintenance perspective review during project design, the development of a specific list of design practices may be appropriate to address maintenance needs in a particular area. Agencies need to recognize the liability that O&M needs brings and prioritize the mitigation of key risks accordingly using risk management approaches. While mitigation measures may be costly, the cost of not implementing measures that are critical to health and safety are often much higher. The lifecycle cost would have to be grossly disproportionate to the benefit for it to be ignored.

## **Further research and study**

Areas that would benefit from further research and study include:

- Costs and benefits of critical design options to establish dimensional criteria and guidance, including examples.
- Statistical analysis of maintenance personnel incidents and development of substantive crash prediction methods to guide the geometric design of alternatives that affect work zone safety, enforcement, incident management options.
- Better understanding of the short and long-term risks concerning the operation and maintenance of facilities that use ITS technology.

# References

CIRIA Report C686 "Safe Access for Maintenance and Repair. Guidance for designers 2nd edition 2009

<http://apps.trb.org/cmsfeed/TRBNetProjectDisplay.asp?ProjectID=373>

FHWA LCCA model - <https://www.fhwa.dot.gov/infrastructure/asstmgmt/lccasoft.cfm>

Interim Advice Note 69/15, Designing For Maintenance (April 2015), Highways England Roads in Hertfordshire: Highway Design Guide 3rd Edition, Section 2: Highway Layout and Strategies, Chapter 7: Design for Maintenance

Maintenance Considerations in Highway Design, Road Engineering Journal, Copyright © 1997 by TranSafety, Inc.

National Highway Research Program (NCHRP) Project 14-9 (2) and NCHRP Report 349 "Maintenance Considerations in Highway Design"

The Institute of Asset Management, Asset Management – an anatomy, Version 2, July 2014, [www.theiam.org](http://www.theiam.org)

Washington State Department of Transportation, Design Manual M 22-01.11, July 2014

## Appendix E: The Future AASHTO Green Book

# Part I – Fundamentals of Geometric Design

## Chapter 1: Geometric Design and Project Development

- 1.1. Definition of Geometric Design
- 1.2. Overview of Road and Highway Project Development Process
- 1.3. Road Users
- 1.4. Purpose and Function of Geometric Design
- 1.5. Elements of Context Influencing Geometric Design
- 1.6. Environmental and Social Policies Influencing Geometric Design
- 1.7. Stakeholders and Their Roles in Project Development

## Chapter 2: The Geometric Design Framework

- 2.1. Basic Geometric Design Elements
  - 2.1.1. Alignment (Horizontal and Vertical)
  - 2.1.2. Cross Section (including Roadside)
  - 2.1.3. Intersections
- 2.2. Speed and Geometric Design
- 2.3. Geometric Design Addresses Transportation Problems (Mobility, Access, Safety, State-of-Good Repair)
- 2.4. Principles of Cost-effectiveness and Trade-offs in Geometric Design and Project Development
  - Performance Metrics
    - 2.4.1. Mobility -- Travel time, speed, delay, variance
    - 2.4.2. Accessibility – Routing, access control, pedestrian and bicycle accommodation, transit accommodation
    - 2.4.3. Safety -- Crash Frequency and Severity;
    - 2.4.4. State-of-Good Repair – Road surface and bridge condition; Operations and Maintenance functions and needs)
- 2.5. Basic Project Types and Performance (Reference to Part II)
  - 2.5.1. New Construction
  - 2.5.2. Reconstruction
  - 2.5.3. Rehabilitation, Resurfacing or Repair
- 2.6. Roadway Context Considerations
  - 2.6.1. Location (Rural, Suburban, Urban)
  - 2.6.2. Adjacent Land Use ('Context Zones)
  - 2.6.3. Functional Classification
  - 2.6.4. Typical or Expected Road User Types (Motor vehicles, Trucks, Transit Buses, Special Vehicle Types, Pedestrians, Bicyclists, Disabled)
- 2.7. Design Controls by Context (Design or Target Speed, Design Traffic Volume, Design User types, Design Traffic, Design Operations or 'Level of Service', Design Year and Service Life)

## Chapter 3 – Road User Performance Characteristics

- 3.1. Design Vehicle Types
  - 3.1.1. Physical Characteristics
  - 3.1.2. Operational Performance
  - 3.1.3. Relationship to Geometric Design Elements (Alignment, Cross Section, Roadside)
- 3.2. Motorcyclists
- 3.3. Pedestrians and Bicyclists
  - 3.3.1. Walking Speeds
  - 3.3.2. Intersections
  - 3.3.3. Vehicle/Pedestrian Conflicts
- 3.4. Special Vehicle Types



- 3.5. The 'Design Driver' – Human Factors Inputs to Geometric Design (Reference to TRB Human Factors Guide)
  - 3.5.1. The Driving Task
  - 3.5.2. Perception and Reaction
  - 3.5.3. Expectancy
  - 3.5.4. Driver Capabilities
  - 3.5.5. Older Drivers
- 3.6. Traffic Flow Relationships (Reference to TRB Highway Capacity Manual)
  - 3.6.1. Speed-Volume-Density Relationships
  - 3.6.2. Intersection Operations
  - 3.6.3. Basics of Highway Capacity (Uninterrupted flow, intersections, weaving, merging and diverging)
  - 3.6.4. Basic Principles of Access Management
- 3.7. Congestion
- 3.8. Safety Performance Relationships (Reference to AASHTO Highway Safety Manual)
- 3.9. Fundamentals of Crash Risk and Measurement
  - 3.9.1. Relationship of Volume to Frequency
  - 3.9.2. Crash Types and Severity
  - 3.9.3. Crash Risk and Speed
  - 3.9.4. Crash Risk by Context Conditions
  - 3.9.5. Crash Risk and Geometric Design Elements

#### **Chapter 4: Elements of Geometric Design – Alignment and Cross Section**

- 4.1. Sight Distance
  - 4.1.1. Stopping
  - 4.1.2. Passing
  - 4.1.3. Intersection
  - 4.1.4. Decision
  - 4.1.5. Maneuver
- 4.2. Horizontal Alignment
  - 4.2.1. Design Models and Assumptions\* (comfort, risk based, other)
  - 4.2.2. Horizontal Stopping Sight Distance
- 4.3. Superelevation
  - 4.3.1. Design Rates by Context
  - 4.3.2. Runoff and runout
  - 4.3.3. Spiral Transitions
- 4.4. Vertical Alignment
  - 4.4.1. Grades (Maximum and Minimum)
  - 4.4.2. Vertical Curvature (Crest, Sag)
  - 4.4.3. Basis for Design – Stopping Sight Distance
  - 4.4.4. Stopping Sight Distance Profiles and Design Risk
- 4.5. Coordination of Horizontal and Vertical Alignment
  - 4.5.1. Operational Effects of Combinations of Alignment
  - 4.5.2. Drainage and Maintenance effects of Combinations of Alignment
- 4.6. Cross Section Elements
  - 4.6.1. Traveled Way (Lanes and Lane Width)
  - 4.6.2. Shoulders (Width and Type)
  - 4.6.3. Medians (Width and Type)
  - 4.6.4. Roadside (Slopes, Ditches, Clear Zone) – Reference to AASHTO Roadside Design Guide
  - 4.6.5. Roadside Barriers – Reference to AASHTO Roadside Design Guide
  - 4.6.6. Lateral Offset

- 4.6.7. Curbs
- 4.6.8. Pedestrian Facilities (Combined with Roadway; widths and offsets)
- 4.6.9. Bicycle Roadways (Combined with Roadway; widths, offsets and locations)
- 4.6.10. Maintenance Needs within the Cross Section
- 4.7. Other Roadway Needs and Functions Influencing Geometric Design Elements
  - 4.7.1. Drainage, Erosion Control and Landscaping
  - 4.7.2. Lighting
  - 4.7.3. Utilities
  - 4.7.4. Traffic Control Devices (Reference to FHWA Manual on Uniform Traffic Control Devices)
  - 4.7.5. Planning for Traffic Management during Construction or Major Maintenance

## **Chapter 5 – Elements of Geometric Design – Intersections**

- 5.1. Introduction
  - 5.1.1. Importance of Left Turns in Operational efficiency and safety
  - 5.1.2. Importance of Speed and Speed Control
  - 5.1.3. Integration of Traffic Control
- 5.2. General Design Considerations
  - 5.2.1. Trade-offs in allocation of available width
  - 5.2.2. Intersection type and context
  - 5.2.3. Needs of Road Users
  - 5.2.4. Intersection Capacity and Operations
  - 5.2.5. Intersection Crash Risk
- 5.3. Intersection Types
  - 5.3.1. Number of Legs
  - 5.3.2. Angle(s) of intersection/skew
  - 5.3.3. Type of Traffic Control
  - 5.3.4. Context (Presence of Pedestrians and other vulnerable road users)
- 5.4. Alignment and Profile Design
  - Lanes and Lane Width
- 5.5. Intersection Sight Distance
- 5.6. Turning Roadways and Channelization
  - 5.6.1. Left Turn Lane(s)
  - 5.6.2. Right Turn Lane(s)
- 5.7. Auxiliary Lanes
- 5.8. Medians and Median Openings
- 5.9. Incorporating Pedestrian Accessibility and Mobility within Intersection Design
- 5.10. Operational Solutions to Intersection Problems (e.g., turn prohibitions)
- 5.11. Design Solutions to Intersection Problems
  - 5.11.1. Indirect Left Turns and U-turns
  - 5.11.2. Wide Medians and U-turn Crossover Designs
  - 5.11.3. Continuous Flow Intersections
- 5.12. Roundabouts (Reference to the Latest AASHTO or FHWA document on Roundabout Design)
  - 5.12.1. General Principles, including trade-offs involving safety performance, right-of-way, pedestrian mobility and traffic operations
  - 5.12.2. Geometric Elements of Roundabouts
- 5.13. Railroad/Highway Grade Crossings
- 5.14. Trail Crossings – Non-motorized travel (Pedestrian, Bicycle, Equestrian facilities)

## **Chapter 6 : Elements of Geometric Design – Interchanges and Interchange Ramps**

- 6.1. Types of Interchanges
  - 6.1.1. Service Interchanges
  - 6.1.2. System Interchanges

- 6.2. Types of Ramps
- 6.3. Access Control
- 6.4. Traffic Operations
- 6.5. Safety
- 6.6. Maintenance Considerations

#### **Chapter 7: Integration of Technology with Geometric Design**

- 7.1. Driverless/connected/autonomous technology
- 7.2. Intelligent Transportation Systems including Real-time Traffic Management
- 7.3. Emergency Services
- 7.4. Managed Lanes

#### **Chapter 8: Overview of the Roadway Geometric Design Process**

- 8.1. Step 1: Define the Transportation Problem or Need
  - 8.1.1. Project Types and Their Needs
  - 8.1.2. Agency Policies and Priorities and Needs Definitions
- 8.2. Step 2: Identify and Charter All Project Stakeholders
  - 8.2.1. Internal Stakeholders
  - 8.2.2. External Stakeholders
- 8.3. Step 3: Develop the Project Scope
- 8.4. Step 4: Determine the Project Type and Design Development Parameters
  - 8.4.1. New Construction
  - 8.4.2. Reconstruction
  - 8.4.3. 3R
- 8.5. Step 5: Establish the Project's Context and Geometric Design Framework
  - 8.5.1. Framework for Geometric Design Process – New/Reconstruction
  - 8.5.2. Develop Project Evaluation Criteria w/in Context Framework
  - 8.5.3. Establish Decision-making Roles and responsibilities
  - 8.5.4. Determine Basic Geometric Design Controls
- 8.6. Step 6: Apply the Appropriate Geometric Design Process and Criteria
- 8.7. Step 7: Designing the Geometric Alternatives
- 8.8. Step 8: Design Decision-Making and Project Documentation
- 8.9. Step 9: Transitioning to Preliminary and Final Engineering
- 8.10. Step 10: Agency Operations and Maintenance Database Assembly
- 8.11. Step 11: Continuous Monitoring and Feedback to Agency Processes and Database

## Part II – Geometric Design Process for New Roads

### **Introduction to Part II**

What is unique about New Roads

Summary of Chapter Contents (Organization by Basic Context Zone/Functional Classification Framework)

### **Chapter 9 – New Construction Design Process Overview**

- 9.1. Step 1: Transportation Problem or Need is Mobility and/or Accessibility
  - 9.1.1. Confirm the new road's compatibility with appropriate jurisdictional policies and plans
  - 9.1.2. Consider all potential road users in needs identification
- 9.2. Step 2: Identify and Charter All Project Stakeholders
  - 9.2.1. Internal Stakeholders
  - 9.2.2. External Stakeholders
- 9.3. Step 3: Develop the Project Scope
- 9.4. Step 4: Confirm the Project Type and Design Development Parameters (New Construction)
- 9.5. Step 5: Establish the Project's Land Use and other Context and Geometric Design Framework

- 9.5.1. Refer to Design Guidance for New Roads (See subsequent Chapters)
- 9.5.2. Develop Project Evaluation Criteria w/in Context Framework
- 9.5.3. Establish Decision-making Roles and responsibilities
- 9.5.4. Determine Basic Geometric Design Controls
- 9.6. Step 6: Apply the Appropriate Geometric Design Criteria
- 9.7. Step 7: Designing the Geometric Alternatives
- 9.8. Step 8: Design Decision-Making and Project Documentation
- 9.9. Step 9: Transitioning to Preliminary and Final Engineering
- 9.10. Step 10: Agency Operations and Maintenance Database Assembly
- 9.11. Step 11: Continuous Monitoring and Feedback to Agency Processes and Database

#### **Chapter 10: New Local and Collector Roads in Rural Context Zones**

- 10.1. Introduction
- 10.2. Appropriate Design Controls (Speed, Vehicle Types)
- 10.3. Expected Performance (Operational, Safety)
- 10.4. Recommended Design Values
  - 10.4.1. Horizontal Alignment
  - 10.4.2. Vertical Alignment
  - 10.4.3. Cross Section Elements
  - 10.4.4. Roadside design
  - 10.4.5. Intersection design

#### **Chapter 11: New Arterial Roads in Rural Context Zones**

- 11.1. Introduction
- 11.2. Appropriate Design Controls (Speed, Vehicle Types)
- 11.3. Expected Performance (Operational, Safety)
- 11.4. Access Control and Management – Integration with Land Use Plans
- 11.5. Recommended Design Controls
  - 11.5.1. Horizontal Alignment
  - 11.5.2. Vertical Alignment
  - 11.5.3. Cross Section
  - 11.5.4. Roadside design
  - 11.5.5. Intersection design

#### **Chapter 12: New Freeways and Fully Controlled Access Highways in Rural Context Zones**

- 12.1. Introduction
- 12.2. Appropriate Design Controls (Speed, Vehicle Types)
- 12.3. Expected Performance (Operational, Safety)
- 12.4. Access Control and Management – Integration with Land Use Plans
- 12.5. Interchanges
  - 12.5.1. Interchange Locations (Crossroad type, land use, spacing)
  - 12.5.2. Interchange Types and their Characteristics (System, Service)
  - 12.5.3. Ramp Terminal Intersections
- 12.6. Recommended Design Controls - Mainline
  - 12.6.1. Horizontal Alignment
  - 12.6.2. Vertical Alignment
  - 12.6.3. Cross Section
  - 12.6.4. Roadside design
  - 12.6.5. Auxiliary Lane Treatments
- 12.7. Recommended Design Controls – Exit and Entrance Ramps
  - 12.7.1. Horizontal Alignment
  - 12.7.2. Vertical Alignment

- 12.7.3. Cross Section
- 12.7.4. Roadside design
- 12.7.5. Ramp Terminal Design Details

### **Chapter 13: New Local and Collector Roads in Suburban Context Zones**

- 13.1. Introduction
- 13.2. Appropriate Design Controls (Speed, Vehicle Types)
- 13.3. Speed management techniques and solutions
- 13.4. Considerations for Pedestrian and Bicycle Users
- 13.5. Expected Performance (Operational, Safety)
- 13.6. Recommended Design Values
  - 13.6.1. Horizontal Alignment
  - 13.6.2. Vertical Alignment
  - 13.6.3. Cross Section Elements
  - 13.6.4. Roadside design
  - 13.6.5. Intersection and Roundabout design

### **Chapter 14: New Arterial Roads in Suburban Context Zones**

- 14.1. Introduction
- 14.2. Appropriate Design Controls (Speed, Vehicle Types)
- 14.3. Expected Performance (Operational, Safety)
- 14.4. Access Control and Management – Integration with Land Use Plans
- 14.5. Recommended Design Controls
  - 14.5.1. Horizontal Alignment
  - 14.5.2. Vertical Alignment
  - 14.5.3. Cross Section
  - 14.5.4. Roadside design
  - 14.5.5. Intersection and Roundabout design
  - 14.5.6. Arterial to arterial Interchanges and Grade Separations

### **Chapter 15: New Freeways and Fully Controlled Access Highways in Suburban Context Zones**

- 15.1. Introduction
- 15.2. Appropriate Design Controls (Speed, Vehicle Types)
- 15.3. Expected Performance (Operational, Safety)
- 15.4. Access Control and Management – Integration with Land Use Plans
- 15.5. Interchanges
  - 15.5.1. Interchange Locations (Crossroad type, land use, spacing)
  - 15.5.2. Interchange Types and their Characteristics (System, Service)
  - 15.5.3. Congestion / Demand Management
  - 15.5.4. Ramp Terminal Intersections
- 15.6. Recommended Design Controls -- Mainline
  - 15.6.1. Horizontal Alignment
  - 15.6.2. Vertical Alignment
  - 15.6.3. Cross Section
  - 15.6.4. Roadside design
  - 15.6.5. Auxiliary Lanes
- 15.7. Recommended Design Controls – Exit and Entrance Ramps
  - 15.7.1. Horizontal Alignment
  - 15.7.2. Vertical Alignment
  - 15.7.3. Cross Section
  - 15.7.4. Roadside design
  - 15.7.5. Ramp Arrangements and Spacing

- 15.8. Special Design Features
  - 15.8.1. HOV/HOT Design Solutions
  - 15.8.2. Transit Park 'n' ride Facilities

### **Chapter 16: New Local and Collector Roads in Urban Context Zones**

- 16.1. Introduction
- 16.2. Appropriate Design Controls (Speed, Vehicle Types)
- 16.3. Speed Management Techniques and Solutions
- 16.4. Expected Performance (Operational, Safety)
- 16.5. Recommended Design Values
  - 16.5.1. Horizontal Alignment
  - 16.5.2. Vertical Alignment
  - 16.5.3. Cross Section Elements
  - 16.5.4. Roadside design
  - 16.5.5. Intersection design
- 16.6. Operational Solutions for Pedestrian Mobility and Safety
- 16.7. Design for Bicycle Lanes
- 16.8. Loading Zones and Transit Stops

### **Chapter 17: New Arterial Roads in Urban Context Zones**

- 17.1. Introduction
- 17.2. Appropriate Design Controls (Speed, Vehicle Types)
- 17.3. Expected Performance (Operational, Safety)
- 17.4. Access Control and Management – Integration with Land Use Plans
- 17.5. Recommended Design Controls
  - 17.5.1. Horizontal Alignment
  - 17.5.2. Vertical Alignment
  - 17.5.3. Cross Section
  - 17.5.4. Roadside design
  - 17.5.5. Intersection Design
- 17.6. Operational Solutions for Pedestrian Mobility and Safety
- 17.7. Design for Bicycle Lanes
- 17.8. Loading Zones and Transit Stops

### **Chapter 18: New Freeways and Fully Controlled Access Highways in Urban Context Zones**

- 18.1. Introduction
- 18.2. Appropriate Design Controls (Speed, Vehicle Types)
- 18.3. Expected Performance (Operational, Safety)
- 18.4. Access Control and Management – Integration with Land Use Plans
- 18.5. Interchanges
  - 18.5.1. Interchange Locations (Crossroad type, land use, spacing)
  - 18.5.2. Interchange Types and their Characteristics (System, Service)
  - 18.5.3. Congestion / Demand Management
  - 18.5.4. Ramp Terminal Intersections
- 18.6. Recommended Design Controls -- Mainline
  - 18.6.1. Horizontal Alignment
  - 18.6.2. Vertical Alignment
  - 18.6.3. Cross Section
  - 18.6.4. Roadside design
  - 18.6.5. Auxiliary Lanes
- 18.7. Recommended Design Controls – Exit and Entrance Ramps
  - 18.7.1. Horizontal Alignment

- 18.7.2. Vertical Alignment
- 18.7.3. Cross Section
- 18.7.4. Roadside design
- 18.7.5. Ramp Arrangements and Spacing
- 18.8. Special Design Features
  - 18.8.1. HOV/HOT Design Solutions
  - 18.8.2. Transit Park 'n' ride Facilities

## Part III– Geometric Design Process for Roads to be Reconstructed

### Introduction to Part III

What is unique about reconstructed roads versus new road

Agency Policies associated with reconstruction of roads

Project and Service Life

Crash cost valuations

Travel time valuations

Discount or interest rate assumptions

Threshold B/C values for acceptable solutions

Summary of Chapter Contents (Organization by Basic Context Zone/Functional Classification Framework)

### Chapter 19 – Reconstruction Design Process Overview

- 19.1. Step 1: Transportation Problem or Need may be safety based, mobility or access based, or 'state-of-good repair' based
  - 19.1.1. Safety
  - 19.1.2. Mobility or Access
  - 19.1.3. Facility Condition
  - 19.1.4. Consider all potential road users in needs identification
- 19.2. Step 2: Identify and Charter All Project Stakeholders
  - 19.2.1. Internal Stakeholders
  - 19.2.2. External Stakeholders
- 19.3. Step 3: Develop the Project Scope
- 19.4. Step 4: Confirm the Project Type and Design Development Parameters (Reconstruction)
- 19.5. Step 5: Confirm the Project's Land Use and other Context and Geometric Design Framework
  - 19.5.1. Develop Project Evaluation Criteria w/in Context Framework
  - 19.5.2. Establish Decision-making Roles and responsibilities
  - 19.5.3. Determine Basic Geometric Design Controls
- 19.6. Step 6: Apply the Appropriate Geometric Analysis Procedures
- 19.7. Step 7: Designing the Geometric Alternatives – Focus on solving the problem(s)
- 19.8. Step 8: Design Decision-Making and Project Documentation
- 19.9. Step 9: Transitioning to Preliminary and Final Engineering
- 19.10. Step 10: Agency Operations and Maintenance Database Assembly
- 19.11. Step 11: Continuous Monitoring and Feedback to Agency Processes and Database

### Chapter 20: Reconstructed Local and Collector Roads in Rural Context Zones

Introduction – Solve the Problem(s)

- 20.1. Solutions to Crashes by Type and Severity (Reference AASHTO Highway Safety Manual and FHWA CMF Clearinghouse)
- 20.2. Maintenance and Operational Considerations in solution development
- 20.3. Cost-effectiveness demonstration
- 20.4. Documentation and monitoring of solutions after implementation

## **Chapter 21: Reconstructed Arterial Roads in Rural Context Zones**

Introduction – Solve the Problem(s)

- 21.1. Solutions to Crashes by Type and Severity (Reference AASHTO Highway Safety Manual and FHWA CMF Clearinghouse)
  - 21.1.1. Run-off-road
  - 21.1.2. Intersection
  - 21.1.3. Other
- 21.2. Solutions to Traffic Operational Problems (Reference TRB Highway Capacity Manual)
  - 21.2.1. Localized Congestion
  - 21.2.2. Demand exceeds capacity for current and/or design year
  - 21.2.3. Truck operations/speed differentials
  - 21.2.4. Other
- 21.3. Maintenance and Operational Considerations in solution development
- 21.4. Cost-effectiveness demonstration
- 21.5. Documentation and monitoring of solutions after implementation
- 21.6. Reconstructed roads with fundamental changes in their character
  - 21.6.1. Crash and operational history may not apply
  - 21.6.2. Right-of-way limitations, access control and other constraints may apply
  - 21.6.3. Refer to Chapter 11 for guidance on design values\*
- 21.7. \*Guidance on trade-off dimensions from ‘New Road’ Criteria
  - 21.7.1. Cross Section (lane, shoulder width reductions)
  - 21.7.2. Horizontal Alignment (curvature)
  - 21.7.3. Vertical Alignment (Vertical curvature)
  - 21.7.4. Roadside design
- 21.8. Cost-effectiveness demonstration (examples) using CMFs, HSM and HCM techniques, design traffic, historic and projected crash data, operational simulations, project life and service life of trade-off analysis of dimensions

## **Chapter 22: Reconstructed Freeways and Controlled Access Facilities in Rural Context Zones**

Introduction – Solve the Problem(s)

- 22.1. Solutions to Crashes by Type and Severity (Reference AASHTO Highway Safety Manual and FHWA CMF Clearinghouse)
  - 22.1.1. Run-off-road including barrier
  - 22.1.2. Interchange ramp
  - 22.1.3. Wrong-way driving
- 22.2. Solutions to Traffic Operational Problems (Reference TRB Highway Capacity Manual)
  - 22.2.1. Localized Congestion
  - 22.2.2. Demand exceeds capacity for current and/or design year
  - 22.2.3. Truck operations/speed differentials
  - 22.2.4. Other
- 22.3. Maintenance and Operational Considerations
- 22.4. Cost-effectiveness demonstration
- 22.5. Documentation and monitoring of solutions after implementation
- 22.6. Reconstructed roads with fundamental changes in their character
  - 22.6.1. Crash and operational history may not apply
  - 22.6.2. Right-of-way limitations, access control and other constraints may apply
  - 22.6.3. Refer to Chapter 11 for guidance on design values\*
- 22.7. \*Guidance on trade-off dimensions from ‘New Road’ Criteria
  - 22.7.1. Cross Section (lane, shoulder width reductions)
  - 22.7.2. Horizontal Alignment (curvature)



- 22.7.3. Vertical Alignment (Vertical curvature)
- 22.7.4. Roadside design
- 22.8. Cost-effectiveness demonstration

### **Chapter 23: Reconstructed Local and Collector Roads in Suburban Context Zones**

Introduction – Solve the Problem(s)

- 23.1. Solutions to Crashes by Type and Severity (Reference AASHTO Highway Safety Manual and FHWA CMF Clearinghouse)
  - 23.1.1. Run-off-road
  - 23.1.2. Intersection
  - 23.1.3. Pedestrian-involved
- 23.2. Maintenance and Operational Considerations in solution development
- 23.3. Cost-effectiveness demonstration
- 23.4. Documentation and monitoring of solutions after implementation

### **Chapter 24: Reconstructed Arterial Roads in Suburban Context Zones**

Introduction – Solve the Problem(s)

- 24.1. Solutions to Crashes by Type and Severity
- 24.2. Solutions to Traffic Operational Problems (Reference TRB Highway Capacity Manual)
- 24.3. Maintenance and Operational Considerations
- 24.4. Cost-effectiveness demonstration
- 24.5. Documentation and monitoring of solutions after implementation
- 24.6. Reconstructed roads with fundamental changes in their character
- 24.7. \*Guidance on trade-off dimensions from ‘New Road’ Criteria
  - 24.7.1. Cross Section (lane, shoulder width reductions)
  - 24.7.2. Horizontal Alignment (curvature)
  - 24.7.3. Vertical Alignment (Vertical curvature)
  - 24.7.4. Median width
  - 24.7.5. Turning lane widths
  - 24.7.6. Roadside design
- 24.8. Cost-effectiveness

### **Chapter 25: Reconstructed Freeways and Controlled Access Facilities in Suburban Context Zones**

Introduction – Solve the Problem(s)

- 25.1. Solutions to Crashes by Type and Severity (Reference AASHTO Highway Safety Manual and FHWA CMF Clearinghouse)
  - 25.1.1. Run-off-road including barrier
  - 25.1.2. Interchange ramp
  - 25.1.3. Wrong-way driving
- 25.2. Solutions to Traffic Operational Problems (Reference TRB Highway Capacity Manual)
  - 25.2.1. Localized Congestion
  - 25.2.2. Demand exceeds capacity for current and/or design year
  - 25.2.3. Truck operations/speed differentials
  - 25.2.4. Other
- 25.3. Maintenance and Operational Considerations in solution development
- 25.4. Cost-effectiveness demonstration
- 25.5. Documentation and monitoring of solutions after implementation
- 25.6. Reconstructed roads with fundamental changes in their character
  - 25.6.1. Crash and operational history may not apply
  - 25.6.2. Right-of-way limitations, access control and other constraints may apply
  - 25.6.3. Refer to Chapter 11 for guidance on design values\*

- 25.7. \*Guidance on trade-off dimensions from ‘New Road’ guidance where constraints impose important adverse costs or impacts
  - 25.7.1. Cross Section (lane, shoulder width reductions; shoulder conversion to auxiliary lane)
  - 25.7.2. Horizontal Alignment (curvature)
  - 25.7.3. Vertical Alignment (Vertical curvature)
  - 25.7.4. Roadside design
  - 25.7.5. Bridge Clearance
- 25.8. Cost-effectiveness demonstration (examples) using CMFs, HSM and HCM techniques, design traffic, historic and projected crash data, operational simulations, project life and service life of trade-off analysis of dimensions

## **Chapter 26: Reconstructed Local and Collector Roads in Urban Context Zones**

Introduction – Solve the Problem(s)

- Speed and speed management may be a primary problem
- 26.1. Solutions to Crashes by Type and Severity (Reference AASHTO Highway Safety Manual and FHWA CMF Clearinghouse)
  - 26.1.1. Intersection
  - 26.1.2. Pedestrian involved
- 26.2. Maintenance and Operational Considerations in solution development
- 26.3. Cost-effectiveness demonstration (examples) using CMFs, HSM techniques, design traffic, project life and service life
- 26.4. Documentation and monitoring of solutions after implementation

## **Chapter 27: Reconstructed Arterial Roads in Urban Context Zones**

Introduction – Solve the Problem(s)

- 27.1. Solutions to Crashes by Type and Severity (Reference AASHTO Highway Safety Manual and FHWA CMF Clearinghouse)
  - 27.1.1. Intersection
  - 27.1.2. Pedestrian involved
- 27.2. Solutions to Traffic Operational Problems (Reference TRB Highway Capacity Manual)
  - 27.2.1. Localized Congestion
  - 27.2.2. Demand exceeds capacity for current and/or design year
  - 27.2.3. Truck operations/speed differentials
  - 27.2.4. Transit loading zone conflicts
  - 27.2.5. Other
- 27.3. Maintenance and Operational Considerations in solution development
- 27.4. Cost-effectiveness demonstration
- 27.5. Documentation and monitoring of solutions after implementation
- 27.6. Reconstructed roads with fundamental changes in their character
  - 27.6.1. Crash and operational history may not apply
  - 27.6.2. Right-of-way limitations, access control and other constraints may apply
  - 27.6.3. Refer to Chapter 17 for guidance on design values\*
- 27.7. \*Guidance on trade-off dimensions from ‘New Road’ guidance where constraints impose important adverse costs or impacts
  - 27.7.1. Cross Section (lane, shoulder width reductions)
  - 27.7.2. Horizontal Alignment (curvature)
  - 27.7.3. Vertical Alignment (Vertical curvature)
- 27.8. Cost-effectiveness demonstration (examples) using CMFs, HSM and HCM techniques, design traffic, historic and projected crash data, operational simulations, project life and service life of trade-off analysis of dimensions

## Chapter 28: Reconstructed Freeways and Controlled Access Facilities in Urban Context Zones

Introduction – Solve the Problem(s)

- 28.1. Solutions to Crashes by Type and Severity (Reference AASHTO Highway Safety Manual and FHWA CMF Clearinghouse)
  - 28.1.1. Rear-end and sideswipe/weaving related
  - 28.1.2. Run-off-road including barrier
  - 28.1.3. Interchange ramp
  - 28.1.4. Wrong-way driving
- 28.2. Solutions to Traffic Operational Problems (Reference TRB Highway Capacity Manual)
  - 28.2.1. Localized Congestion
  - 28.2.2. Demand exceeds capacity for current and/or design year
  - 28.2.3. Truck operations/speed differentials
  - 28.2.4. Weaving
- 28.3. Maintenance and Operational Considerations in solution development
- 28.4. Cost-effectiveness
- 28.5. Documentation and monitoring of solutions after implementation
- 28.6. Reconstructed roads with fundamental changes in their character
  - 28.6.1. Crash and operational history may not apply
  - 28.6.2. Right-of-way limitations, access control and other constraints may apply
  - 28.6.3. Refer to Chapter 18 for guidance on design values\*
- 28.7. \*Guidance on trade-off dimensions from ‘New Road’ guidance where constraints impose important adverse costs or impacts
  - 28.7.1. Cross Section (lane, shoulder width reductions)
  - 28.7.2. Horizontal Alignment (curvature)
  - 28.7.3. Vertical Alignment (Vertical curvature)
  - 28.7.4. Ramp location, dimensions
- 28.8. Cost-effectiveness demonstration

## Part IV – Roads Requiring Resurfacing, Restoration or Rehabilitation (‘3R)

### Introduction to Part IV

Unique Considerations for ‘3R’ projects versus other project types  
Summary of Chapter Contents

### Chapter 29 – 3R Process for All Road Types and Contexts

- 29.1. Problem Types
  - 29.1.1. State-of-good repair
  - 29.1.2. Safety thresholds are not met
  - 29.1.3. Traffic operational problems
  - 29.1.4. Relationship between disrepair and maintenance activities
- 29.2. Complete the design and construction of the project to address the problem
- 29.3. Operational Issues
- 29.4. Geometric Features to Remain
- 29.5. Maintainability Considerations
- 29.6. Systemwide implementation of ‘low cost safety improvements.’