

IMPROVEMENT OF THE FAIRBANKS ATMOSPHERIC CARBON  
MONOXIDE TRANSPORT MODEL -- A PROGRAM  
FOR CALIBRATION, VERIFICATION AND IMPLEMENTATION

by

Robert F. Carlson  
Director, and Professor of Hydrology  
and  
Charlotte Hok  
Laboratory Assistant

Institute of Water Resources  
University of Alaska  
Fairbanks, Alaska 99701

Completion Report IWR 80-17

October, 1980

Prepared for:

STATE OF ALASKA  
DEPARTMENT OF TRANSPORTATION AND PUBLIC FACILITIES  
DIVISION OF PLANNING & PROGRAMMING  
RESEARCH SECTION  
2301 Peger Road  
Fairbanks, Alaska 99701

The opinions, findings and conclusions expressed in this publication are those of the author and are not necessarily those held by the State of Alaska.

## PREFACE

For over a decade the relationship between high levels of ambient carbon monoxide and automobile emissions has been documented for the city of Fairbanks. This relationship of highway transportation and air pollution inextricably links the Department of Transportation and Public Facilities to the search for plausible air pollution control strategies at the planning and programming level as well as for environmental assessment during design and construction. With high carbon monoxide levels being recorded in other Alaskan cities the potential need for the Department to consider the air pollution problem on a statewide basis becomes more evident. This project was undertaken to survey the potential for up-grading and implementing a carbon monoxide dispersion computer model on a broader basis than used to date which would support the planning process and aid in environmental impact assessment.

L.E. Leonard  
Chief of Energy and  
Buildings Research

## TABLE OF CONTENTS

INTRODUCTION. . . . .	2
OBJECTIVES. . . . .	4
METHODS . . . . .	6
RESULTS . . . . .	7
DOTPF Planning Division. . . . .	7
DOTPF Environmental Division . . . . .	9
Local Agencies . . . . .	11
Alaska Department of Environmental Conservation. . . . .	15
U.S. Environmental Protection Agency . . . . .	17
RECOMMENDATIONS . . . . .	18
Emissions. . . . .	20
Meteorology. . . . .	20
Health . . . . .	20
Transport of CO. . . . .	21
SUMMARY . . . . .	23
APPENDIX I. . . . .	26
REFERENCES . . . . .	I-46

## INTRODUCTION

In the early 70s, state, local and federal officials in Fairbanks, Alaska, became concerned with the rising incidence of high carbon monoxide episodes. Because of that concern, the Alaska Department of Highways (forerunner of the Department of Transportation and Public Facilities) and the Fairbanks North Star Borough requested that the Institute of Water Resources undertake a study to develop a computer model capability for understanding the transport of carbon monoxide and other pollutants within the Fairbanks airshed. The work was completed in June of 1976. Two publications (Carlson and Fox, 1976; Norton and Carlson, 1976) describe the initial development, documentation and implementation of the computer model. The model, ACOSP (Atmospheric Carbon monOxide Simulation Program), describes the two-dimensional behavior of pollutants in the atmosphere via solution of the convection-diffusion equation using the finite element method of numerical analysis.

The project staff worked with the Department of Highways and local borough officials to develop a model tailored to the particular conditions of a small northern urban area. The resulting program has a flexible but powerful computation algorithm which, although needing a large computer, is extremely fast and efficient. The program takes full advantage of the finite element computational method which allows a great deal of flexibility to adapt the solution to the particular problem.

There are four kinds of data for the program, each of which must be carefully prepared for the particular problem at hand. These are: carbon monoxide sources, meteorology, carbon monoxide concentration measurements, and bookkeeping.

The primary input to the model includes an accurate set of carbon monoxide vehicle and stationary source data. The vehicle source data are expressed in terms of total vehicle distance traveled, amount of carbon monoxide emissions per unit distance, number of cold starts, emissions per cold start, time of vehicle idling, and emissions per unit time of idling. Stationary sources (such as homes and power plants) are expressed as point (emissions per unit time) or areal sources (emissions per unit area).

A faithful reproduction of atmospheric conditions present in the airshed at a given time must be specified. This is characterized in the model by the wind speed, a dispersion or mixing coefficient, and the depth of the mixing layer near the ground. The depth is determined from information about temperature inversion conditions and turbulent mixing.

A set of carbon monoxide concentrations is required. These measurements establish the initial conditions for simulation throughout an area of concern, and they determine the boundary conditions across which CO comes into the system.

Certain kinds of bookkeeping data must be provided as input to the model such as specifications on road network configuration, simulation time span, time interval for the computations, and geographical extent of the simulation area. Specifications must also be made for output format.

The strength of the finite element method was used in the program to allow the complete rearrangement of input data based on the particular condition at hand. In this way, the input can be tailored to exactly match available traffic data and then can be changed at any point in a plan of study.

The problem of understanding the carbon monoxide problem in communities such as Fairbanks or Anchorage involves understanding a complex series of relationships between four separate systems: carbon monoxide sources, emission control, meteorology, and human health. Unless all four are considered together in a systematic, concerted effort, it is highly unlikely that an understanding of the problem will be achieved, or much in the way of improvement will be accomplished through planning and control strategies. The link, of course, between these four separate systems is the transport of carbon monoxide or other pollutants throughout the area. The model attempts to describe this link via a computer simulation scheme.

The first application of the model demonstrated the validity of its formulation, flexibility, and ease of operation. These all have proven to be attractive features to potential users. However, the model has not been widely used, and it seems to be an appropriate time to take the next step in developing a fully operational research predictive capability for carbon monoxide and other problems in Alaskan urban and

industrial areas. With this general goal in mind, the Institute of Water Resources conducted research at the request of the Department of Transportation and Public Facilities.

## OBJECTIVES

The objectives of the project are to improve the existing atmospheric pollutant transport model capability for Alaskan urban and industrial problems (with particular emphasis on transportation and environmental concerns) and to implement and maintain the modeling capability for a wide variety of northern situations. The work is proposed to be carried out in three phases; this report completes the first.

The subobjectives for Phase I are:

1. Review of needs and capabilities for atmospheric contaminant transport modeling in Alaska.
2. Evaluate the state of the art in atmospheric modeling.
3. Summarize existing data and the experience base which would be available for further model development.
4. Prepare the study plan for Phases II and III.

Although not carried out under this work task, the objectives of Phases II and III include:

1. Data collection, assembly, and model calibration.
2. Definition and improvement of the transport model.
3. Demonstration, training, and documentation of the completed package.
4. A continuing program of application of atmospheric transport modeling and training for specified Alaskan urban and industrial situations.

The Phase I work plan was carried out in four tasks. The first included a review of needs and capabilities so that the project would be directed towards the widest possible use of an atmospheric transport model with potential users in local, state, federal and private groups

in Alaska. The second task evaluated the state of the art of atmospheric contaminant transport modeling as it relates to northern conditions. This included a review of special Alaskan conditions, advances in atmospheric transport modeling since the completion of the former study, and a brief overall assessment of the worthiness of the technique of the present model. This task was subcontracted to Resource Management Associates as they were the prime technical developers of the existing model. They have remained active in the pollution transport modeling field in the intervening years. The third task included a summary of the existing data base and experience in Alaska, and will be helpful in understanding how much more experience and data must be acquired before a truly useful modeling effort could be attempted. The fourth task was a discussion of the entire review effort including a suggestion about how a modeling effort may be carried out among various planning, design and research groups in the state. It sets the stage for Phase II. The completion of Phase I should increase the confidence that additional modeling effort would be accepted by users in Alaska and suggests arrangements for continuing participation, review and use in Alaskan industrial and urban areas.

If Phase II is undertaken, it would include limited data collection and a full-scale calibration effort in order to further develop the model as an operational tool. It will answer such questions as: How accurate should a model be? What are the major sources of uncertainty? and How can ongoing data collection improve model accuracy? This phase will be vital if programs on the four main components of the overall problem are to be carried out in a coordinated way. Another part of Phase II will include refinement of the existing model, using Phase I results as guidelines. For example, input data may have to be restructured to more easily conform to existing traffic patterns, or an improved formulation of the meteorological data may now be possible. The final task of Phase II, a very important one, will be training and documentation to insure that personnel in Alaska learn how to use the model for their own air quality problems with a minimum of external assistance. There also will quite likely be an exploration of additional model applications as confidence in its acceptability increases,

and as Alaskan resource protection agencies learn of additional pollutants that may be introduced from expanded industrial and urban activity.

The final phase of the overall work will include a continuing program of improvement, application, and training. This would be a small program which would maintain the model through monitoring, running solutions, assisting in problem set-up, and incorporating improvements suggested by users.

The first phase of this project began in early January 1980, and was completed by the end of August 1980.

This report discusses the methods used in the project, the results, and recommendations for future work on model development. This project can play a useful role as Alaskan resource agencies face new problems in the coming years as further urban and industrial development takes place in a wide variety of environmental settings.

## METHODS

A survey project is best carried out by conducting personal interviews. To initiate these, letters of introduction were addressed to regional supervisors and division directors of the various agencies involved. The responses named appropriate contacts and arrangements were made to visit with each for an hour or more.

The Alaska Department of Transportation and Public Facilities (DOTPF) Planning Division personnel contacted included John Martin and Bill Aberly of the Fairbanks office and Reed Gibby, Statewide Urban Transportation Planning Engineer, in Anchorage. Mike Tinker of Fairbanks and Terry Fleming of Anchorage represented DOTPF's Environmental Division. The Alaska Department of Environmental Conservation (DEC) was represented by Tom Moyer in Fairbanks and Mike Hoyles in Anchorage. Moyer is an employee of the U.S. Environmental Protection Agency (EPA), and Hoyles is a DOTPF employee; both of these people are on work assignment to DEC.

The two areas, Fairbanks and Anchorage, have evolved different governmental organizations to deal with air quality. In Fairbanks, the Fairbanks North Star Borough (FNSB) has taken this responsibility while

in Anchorage the city government has done this. Richard Joy of the FNSB Engineering and Environmental Services spoke of the Fairbanks situation; Leif Anderson and Ron Kane of the Municipality of Anchorage Physical Planning Department and Bob Rasmusson of the Air Pollution Control Agency discussed Anchorage.

Our federal contact was Jim Sweeny, head of the Alaskan office of EPA. The position dealing with air quality had been recently vacated, and no replacement had been appointed.

Several interviews that had been originally considered were not arranged because of time constraints. These included the Juneau-based personnel from the DOTPF Division of Transportation Planning, the DEC Air Quality Division, and the Federal Highway Administration.

The state of the art for atmospheric modeling in northern regions also needed evaluation as part of the project. This task was subcontracted to Resource Management Associates (RMA) of Lafayette, California. RMA reviewed four computerized data bases (see their report, Appendix I) and developed a very readable discussion of mathematical modeling, carbon monoxide, and cold regions. As RMA did the original work of assembling ACOSP they were able to relate the more recent literature to it quite well, noting areas for updating.

## RESULTS

### DOTPF Planning Division

Even though the Fairbanks and Anchorage representatives of DOTPF's Planning Division had different regional perspectives, they concurred that EPA requirements are the main motivation to monitor and model CO concentrations. In Fairbanks, the concept was also stressed that most air quality work is a support function for the department's Environmental Division which is in charge of air quality concerns.

Both offices are involved with traffic flow patterns on existing roadways and with evaluating alternative plans for future projects; both of these missions impact air quality. The Fairbanks office is currently using a model package that gives the option of varying either

overall trip demand or the network (while holding demand constant). Comments regarding the Fairbanks Metropolitan Area Transportation System (FMATS) were critical of its fixed rectangular grid for input data, since existing corridors are not likewise neatly arranged. Neither program has graphics capability, a drawback for output interpretation.

All air quality modeling in Anchorage uses a "rollback" model developed specifically for that area by Mike Hoyles of the Anchorage DEC office. This model differentiates CO concentrations due to area-specific CO emissions from those that are background or areawide. Projected changes in each are calculated and the two segments summed to a predictive figure. No provisions are made for meteorological conditions or the cold-start phenomenon. According to Mr. Gibbey, the model (when properly calibrated) is accepted as valid for point-specific localities.

Data available for model input in the Fairbanks region includes arterial and local traffic counts, number of cold starts, origin and destination studies, and air quality data from the borough offices. These data, it was stressed, are neither complete surveys nor up-to-date. Some confidence was expressed, however, in the traffic counts. The military presence so close to town adds a "black box" component, since traffic on post cannot be monitored for security reasons. The effects of garaging are part of the cold start aspect of the problem, and that is mostly unknown. Air quality data collection is not part of the DOTPF mission in Fairbanks, and they rely on DEC and the borough for this information.

The Anchorage representative spoke only in passing of the existing data base there, since the responsibility is the municipality's. Future monitoring, as he envisioned it, would be enhanced only by grab-bag sampling for CO concentrations.

Actual use of ACOSP by the Fairbanks office (on behalf of the Environmental Section) would be contingent on certain model modifications for ease of use by an untrained clerk and for ease of output interpretation. Free-format input seems to be desirable as well as a spoken-English question-and-answer TSS (time sharing system) program on the front end that would build the proper command file to actually run the program at a given time of day. This would allow utilization of lower cost computer time. A graphics capability that could be output at

a regular hardcopy terminal is very desirable, as would any option to make results more quickly interpretable than they now are. Some concern was expressed about meteorological input, i.e. the "goodness" of wind flow data and the dispersion coefficients.

The Anchorage representative appreciated the model's aspects as they were described to him. He addressed the general problem, stating that DOTPF goals were primarily to satisfy EPA and, secondarily, to reduce CO concentrations. He explained that EPA allows "emission credits" for enforced control strategies (e.g. speed controls), but that he felt cold starts were so important to the northern situation that credits that do not incorporate them are unrealistic. Separation of "trip" and "cold start" components would be desirable in any analytical scheme. He will be interested in programs that will be realistic for decision makers; these would have to include cold starts, and he feels that EPA is coming to recognize this.

Both offices referred to a federal model, the Urban Transportation Planning System (UTPS), which the state has obtained and is putting on-line on the Boeing IBM computer in Seattle. (Its machine language is incompatible with the UACN's (University of Alaska Computer Network) Honeywell, and the state's IBM in Anchorage hasn't got the necessary disk space.) This package has many options, including an air quality routine which apparently calculates CO emissions but not concentrations and does not allow for cold starts. Neither office felt they would often use the air quality routine. Apparently, the Federal Highways Administration will not require anything more of the state beyond the package but that consideration is more appropriate to package options other than air quality.

The Fairbanks office, in summary, stressed model modifications for ease of use and interpretation, and the Anchorage representative (who is not familiar with the model) spoke of the general air quality situation.

#### DOTPF Environmental Division

The Fairbanks and Anchorage offices differ somewhat in their current involvement with air quality matters. The Fairbanks office is

quite active with regard to State projects and occasionally those of other agencies. The Anchorage office, while responsible for air quality documents, has not been actively involved in air quality matters for the last two years, since that responsibility has been taken by the DOTPF assignee to DEC, who is also a liaison between the municipal and state offices.

Both offices are concerned with predictive abilities of a model since they need to extrapolate from on-hand data to twenty or thirty years from now. Fairbanks is using current traffic counts and 1969 origin-destination studies to assess the impact on air quality of different paths of an east-west bypass south of the city. Anchorage, among other projects, is concerned with planning the impacts of a south-side corridor.

To do the work necessary for these evaluations, Fairbanks uses FMATS (the model mentioned by Planning in DOTPF). They also use estimations based on such general factors as locating pollution sources downwind of population centers. For microscale work, they use a simple program that can be run on a desk-top calculator. This program calls for auto emissions and "lumped" meteorological data and calculates results for approximately two right-of-way widths. It allows for modifications of local traffic, for cold starts (without a time factor for transition to operating temperature), and for waiting time at stop lights.

The Anchorage office remarked about EPA's influence and observed that they were now more willing to accept approximate approaches such as line-source models. This was the concept used to model the north-side corridor. This model may not be applicable for the increased traffic flow and pattern complexities when the north-side and south-side corridors are merged ("super-Seward"). The situation will only get more complex and beyond the scope of line models. The office feels that there are enough meteorological data available to start validation of a more sophisticated model. The initiative, though, would have to come from EPA, channeled through the Environmental Division to the Planning Division.

The Fairbanks office also expressed a desire for good mesoscale analytical capability because the use of FMATS or AMATS programs was not

accomplishing this. Portland, Oregon was cited as an example of a good modeling situation. Other pollutants such as cadmium and lead were mentioned as potential problems where this type of modeling would be appropriate. They felt that support of the Federal Highways Administration could be anticipated, but the reaction of EPA (a prime motivation force) is less certain.

### Local Agencies

As mentioned, in Fairbanks the local agency concerned with air quality control is the Fairbanks North Star Borough, through the Engineering and Environmental Services Department. During the interview, the history of EPA involvement was briefly outlined, specifically the 1977 Clean Air Act that empowered EPA to demand an attainment plan from municipalities for a reduced CO level by 1982, with a possible extension to 1987. (The State has already applied for this extension for Fairbanks.) Any attainment plan must be approved by a local policy commission, which is presently composed of the three local mayors (the borough and the cities of Fairbanks and North Pole). In the near future the FMATS committee members may be appointed to replace the local mayors.

The attainment plan that each municipality must propose is actually a local selection from among a series of strategies that EPA has outlined to help achieve the reduced CO levels. FNSB has chosen 12 or 13 as possibly appropriate to this area and is reviewing them. Volume 1 of the Attainment Plan has been published and contains data collection and analysis, an emissions inventory, public input, an emergency plan, a list of strategies to be assessed, and a monitoring program. Current activity is geared to gathering socioeconomic and air quality data.

The attainment plan demanded by EPA, then, is the predominant concern of this office. More locally, they try to assist with and review commercial, industrial, and subdivision plans, although comprehensive indirect source review is not popular and time constraints when working directly with the public often preclude such efforts. Other reviews are made for the State, such as their review of the new expressway south of Fairbanks.

The analytical technique used for the emission survey by the FNSB was the roll-back model developed by Mike Hoyles, DOTPF assignee to the

Anchorage DEC office. EPA's Mobile-1 unit was used for data gathering, but there is concern that it underestimates cold start emissions. When asked if additional modeling would be useful, the reply was affirmative, since it would be useful for review of development plans as well as for strategy analysis, cross-checking "roll-back", and assessing the final attainment plan. Concern was expressed with input parameters (especially the wind field) and with ease of access. Packages that are being implemented in Canadian cities, it was suggested, would have more in common with the northern problems we see here, but EPA might be less inclined to accept them.

The existing data base has been developed from three continuous monitors placed downtown, two operated by the borough and one by the State, and from eight grab-bag samplers which take an 8-hour sample and are moved each year. Concern was reaffirmed about cold starts. EPA seems to be starting to look at it, since it may be the extra increment that could help several cities reach attainment levels.

The prime air quality agency in Anchorage is the municipality, which has designated two departments as responsible for air quality matters, the Physical Planning Department and the Air Pollution Control Agency. The Planning Section has, two years previously, published the base document for the area. This included goals, a description of the air quality planning process, an emissions inventory, a description of the air quality problem, transportation control strategies, and a progress reporting program. DOTPF/DEC-city liaison, Mike Hoyles, did most of the initial work for the emissions inventory. Phase II involves a two-fold analysis of 12 EPA strategies. The analysis will include an in-progress socioeconomic study and an air quality study, which will be done after EPA issues emission factors based on Mobile-2. These have been delayed, and conjecture was offered that this delay would last until cold start effects could be incorporated, since existing models don't account for them and EPA is coming to recognize them as important. The city will be allowed four months to do the analyses once the factors are received.

As well as the EPA-imposed work load, the Physical Planning Department handles traffic flow and parking lot review, but air quality is not

a major factor in decisions except for EPA constraints. These constraints must always be kept in mind, though, as 85% of the CO sources are automobile-associated (the power generation plant is out of the nonattainment area). For example, problem areas are associated with the new mall developments along Northern Lights Boulevard and Benson Avenue, in the Sears Mall area. Elevated CO levels can exist in winds up to 7 mph, which is theoretically unusual. Even though the total number of violation periods has decreased, recent episodes have become more severe, and there was one near alert during the 1979-80 winter.

Project 80's changes, creating a pedestrian mall type atmosphere by narrowing 5th, B, D, and F, will involve major traffic flow changes. Parking meters will be eliminated and 2-hour parking zones will be established, though not as directly convenient to businesses as are current patterns. (This should affect winter idling and cold start contributions to the city core air quality problem.) Bussing is being encouraged, but the system is jammed with ridership now, and there are no funds for additional buses (for which there is a two-year wait for delivery). In-town grade level separations are being planned at intersections to aid traffic flow.

For current air quality analysis, EPA has instructed the municipality to use the roll-back model. This work is done for the municipality by Mike Hoyles. The people in this office would like to see another model and are considering DOTPF's new Urban Transportation Planning System (UTPS) package. Their experience with using the Boeing computer, though, has been that the turn-around is not as good as they would like. Cautious interest was shown in ACOSP, with reservations concerning the lack of good meteorological data. Some data exist for 7th and C Street, but most of it is from the airport, which they felt was too far removed from the area of interest to be valid. They do want a predictive tool, though, that EPA would accept, and their criteria (meteorological control, time effects, traffic patterns) seem to coincide with ACOSP's description.

There is some analytical work that is not being done locally. The Municipality of Anchorage has contracted with GCA of Bedford, Massachusetts, to assist with the strategy analysis. GCA will be evaluating five of the 12 EPA strategies, though the office could not say which

model will be used. Mike Hoyles will evaluate two of the others (including a high-priority A-C Couplet). The Anchorage Air Pollution Control Agency will evaluate another two, and in-house evaluation will be done on three.

The other air quality office designated by the Municipality of Anchorage is the Air Pollution Control Agency, whose duties are data collection and control strategy enforcement. The data collection for CO includes four samplers: one location (7th & C) has six or seven years of data; the second has one year; the third has six months; and the fourth, a PSD site, has one year. All have correlative meteorological data stations (MRIs), which are located on one-story and two-story buildings, forty feet above ground level. In addition to this data collection, Mike Hoyles may collect some 24-hour sequential samples.

Data are also being developed from a voluntary vehicle inspection program. However, participation has been so low that it has been suspended during the summer months. The possibility exists that this will become mandatory. The main enforcement problems are concerned with particulates from stationary sources. All air quality data (CO, S<sub>x</sub>O, and suspended particulates) are kept on file on the state computer in Juneau. Printouts of these can be obtained.

Actual hands-on computer modeling for this office is seen as a possibility but probably not a necessity. Mike Hoyles currently does all the modeling and technical analysis. If another model--such as ACOSP--were to become available, then the two Anchorage offices might consider cooperating to fund a cooperative position which would be charged with modeling responsibilities.

The prognosis for the Anchorage area airshed, as seen by this office, is for a worsening of the CO conditions. The violations of recent years have been during "mild" winters, and more "normal" or "hard" winters might have more severe episodes. Even considering the improvements that can be anticipated by manufacturers' engineering design, the conditions could worsen because it takes relatively little user abuse to foul catalytic converters, like burning regular gas. (On the other hand, the Planning office commented that the problem would solve itself by 1990, specifically because of the manufacturers' design modifications.)

## Alaska Department of Environmental Conservation

The Fairbanks office has largely a review function, overseeing other agencies' plans for conformity with state air quality guidelines. The borough handles the main planning activity, and DOTPF provides the traffic data. Part of the review function also requires input to an SIP (State Improvement Plan) which outlines problems throughout the state and suggests solutions. Once submitted to EPA, this plan becomes mandatory; that is, the state will be committing itself to remedy any problem that is described.

On behalf of agencies who are also involved in FMATS, it was stated that additional modeling is viewed as convenient, especially models that are not season specific and could be used to predict "what the day brings." Meteorological studies and a more precise study of the cold start phenomenon would be necessary prerequisites for a model that would have many users, though this office wouldn't be directly involved. Working toward that goal, part of an EPA-funded cooperative project (called VEAP; Vehicle Emission Analysis Program) between the U.S. Army Cold Regions Research and Engineering Laboratory (CRREL) and DEC, is designed to capture and measure cold start emissions from cars started in garages. It was noted that manufacturers have directed their emissions-reduction programs toward the specific temperature range used in EPA tests and that hydrocarbon emissions increase for both cooler and warmer engine temperatures.

The conversation with the Anchorage office could not be a direct personal interview because of conflicting schedules, but with the synthesis of two telephone conversations we were able to construct the following material.

Two areas of concern surfaced, meteorology and modeling. The emphasis was on meteorological studies, especially during violation episodes. In Anchorage, the episodes tend to be short-term, rising from a base level of 1-2 ppm to 10-15 ppm for a few hours and then returning to base level, with the total annual violation time totaling a week or less. Whether or not it is significant, the wind direction during violation periods (the prevailing winter wind) coincides with the two east-west arterials. The fact that some of the violation periods occur

during times of noticeable winds, e.g. 5 mph, and very little traffic is puzzling. There may be a need for a vertical profile of CO concentration and for analysis of historical data. An unusual meteorological condition, not just emissions, may be largely responsible for high CO values. (The Anchorage situation is viewed as more complex than in Fairbanks, but the winds are not as complex.)

The meteorological data available for analysis consist of: four complete years, plus two incomplete years at 7th & C; one year at a site south of town; and one recently installed neighborhood site. MRIs are out at various locations (some at CO monitoring sites). Long-term sites are located at Elmendorf and the airport. The data suggest that the CO problem is widespread (it is not a "hot spot" situation because peaks can occur at 8:00 p.m. and later) and that the diffusion/dispersion process is not as important here as in the Lower 48 because of extremely low temperatures.

Simulation models of an airshed problem such as this are probably chancy because knowledge is so incomplete. However, if one were used to evaluate and compare alternatives, the same errors would be applied to all cases, and relative assessments could be made. ACOSP is a strong model and includes cold starts and a vertical distribution of CO. Most models calculate CO as inversely proportional to wind speed, but this assumption is not appropriate since the concentration here has been found to be as high at 7 mph as at 1 mph. DOTPF's new UPTS model apparently takes all emissions from all sources and lumps them by zone. All emissions are assigned to mobile sources, and there is no meteorological input.

According to Mr. Hoyles, EPA considers atmospheric pollutant problems to be a straightforward relationship between emissions and concentration levels. He feels, however, that Anchorage has an even more dynamic situation, that a meteorological condition may occasionally dominate more than emissions. He hopes that a combination of an appropriate model and a meteorological study will demonstrate his point, showing that a constant emission rate which is normally acceptable will, during occasional periods, not be acceptable. One ramification he would like to see is EPA recognition that if a 50% reduction in emissions

wouldn't affect violation times, then a 20% reduction would be good enough. He also wants to be able to divide the problem between that caused by meteorology and that by cold starts.

The meteorological studies, a two-year analysis of historical data and development of a Pollution Potential Index, are being undertaken by Sue Ann Bowling of the Geophysical Institute, University of Alaska, Fairbanks. The shape of the lapse rate curve for an area, whether it is sharp or gradual, would be the basis for the index. The incorporation of this into a model with a vertical CO distribution routine that could also handle stationary sources would result in a useful tool for PSD cases (Prevention of Significant Deterioration). It would be useful for the siting of industrial development and would likely be accepted by the State even if EPA did not accept it.

EPA's attention seems to be centering on Anchorage, as it is deteriorating faster and is more like Lower 48 cities than Fairbanks, which is unique and already quite severe. Although Mr. Hoyles acknowledged that modeling will be useful, he also raised questions concerning economy (data files compatible with both UPTS and ACOSP), roughness (e.g., buildings), both stationary and mobile point sources, modeling of the airport, and vertical buoyancy of pollutants. Forecasting abilities are desirable, he concluded, but they imply a degree of understanding which may be far from the current status.

#### U.S. Environmental Protection Agency

The interviewee confirmed the general role of EPA in Alaska as it has been outlined by state and local officials: EPA will not seek direct involvement in each situation, but rather "set the standards" and will be the final judge of how well these standards are being met. Between these two ends of the dialog, they also offer assistance. In the case of modeling, which is considered absolutely necessary, their Seattle office has model-oriented (as opposed to regionally assigned) programmers who maintain a manual of standard models and who are available on a consulting basis to local agencies. For example, they cooperated with Alpetco to modify programs for gas pipeline planning. They

will support any type of effort to define a problem and best choose a strategy. A model need not have EPA "certification", although they depend on their Seattle programmers to review those that are used. They have no vested interest in any model and are very receptive to others' efforts, as they do not develop models but contract out the jobs they need done.

The facts that must be kept foremost for modeling in this situation are the goals imposed by the Clean Air Act. EPA would like to see a relative ranking of air quality attainment strategies and a basis for selecting how many of the ranked strategies need to be implemented. Being attuned to Alaskan needs, though, this office has been lobbying heavily within EPA for attention to the cold-start phenomenon, with some encouraging results.

#### RECOMMENDATIONS

A complete understanding of the carbon monoxide problem in urban Alaska requires understanding a four part system: emission from automobiles and stationary sources; meteorology of the urban area; effects of carbon monoxide on human health; and transport of the contaminant through the airshed. Each is a part of a complex system and plays a part in its solution.

The vehicle-related emissions element can be partially controlled by traffic patterns and emission regulation. This is a prime source of control at the local level. Most control, however, will eventually result from emission regulation due to vehicle design criteria for noncold climates. Understanding emissions and their generation and evaluating traffic and parking control are important parts of the overall system.

Meteorology provides the background environmental condition of the urban airshed. Since carbon monoxide is not directly observable, its movement must be inferred from certain measured values. Because the meteorological elements are complicated by emissions, there is no known clear, direct relationship between them. Therefore, empirical or ad hoc

correlations between meteorology and carbon monoxide level will never provide much information with the degree of confidence necessary to enforce emission or vehicle standards.

Human health effects are one of the more important--yet not well understood or extensively studied--phenomena. There is a definite relationship between high carbon monoxide levels and the effects on humans. Such effects depend on a wide variety of factors such as age, health, length of exposure, and the magnitude of the episode. Human health is usually indirectly considered by specification of acceptable carbon monoxide levels such as 9 ppm in one hour or 37 ppm in eight hours. However, these general specifications ignore potentially more susceptible population centers such as areas with schools, concentrations of younger children, hospitals, and senior citizens' residences.

The fourth element, hybrid in nature, involves an understanding of carbon monoxide movement throughout the airshed. It depends on complete, accurate vehicle operation, parking, and emission data, and it uses meteorological parameters to output a carbon monoxide distribution. This element is a key to understanding the problem, and provides a framework to integrate all data sources. It makes good sense to use the best available tool for understanding this component.

The final goal of this complex four-part systems analysis is provision of a healthy environment for the greatest number of people at the least cost. The problem is especially difficult because the system is complex, measurements of reality are necessarily quite imperfect, and many administrative and political jurisdictions are involved. Therefore, it is hard for any one party to specify or work on the complete range of the problem.

Before the whole problem can be solved, the various parties involved must achieve the best understanding of each component. With the above introduction in mind, we have made brief recommendations for the first three components and detailed recommendation for carbon monoxide transport.

## Emissions

1. Continuing efforts should be made to understand the special effects of cold weather operation, emphasizing cold starts.
2. A concerted effort should be made to completely document vehicle movement, particularly with regards to large military bases within urban areas.
3. Attention should be given to the maintainability over time of various emission control devices.

## Meteorology

1. An attempt should be made to gain a better understanding of the wind field, inversion heights, and dispersion coefficients.
2. Special attention should be made with respect to the geography, particularly in areas of ravines and ridges.
3. A special effort should be made to understand the near-surface meteorological environment, since this is the critical area in which many of the emissions occur and in which the primary part of the health problem takes effect.

## Health

1. Attempts should be made to understand the relationship between the specified permissible limits of carbon monoxide and human health. It is possible that a number of health problems are being exacerbated at CO levels much below the permissible levels, and their extent should be known. Unless an accurate CO level-health relationship is established, the public will have little confidence in measures to relieve excessive carbon monoxide concentrations.

## Transport of CO

1. As a result of this review, it appears that ACOSP is one of the best models available for an understanding of urban air pollution problems in Alaska. The finite-element method of computation appears to be simple and straightforward. There is little need to improve upon it by an adaptation of more complex empirical or computational schemes. There is a need to do some relatively minor updating of the program--mainly in the efficiency of various computations.
2. A great deal of serviceability could be added to the use of the model by improvements to the input routines. These would allow easy data loading by nontechnical personnel.
3. The program's output routines could be improved to provide easily interpretable graphical printout.
4. Input data format could be made compatible with the UTPS requirements to allow economy of data preparation.

We recommend that Phase II of the original proposal be implemented at the earliest possible date. The problem is so complex that ad hoc correlations between vehicle traffic, meteorological parameters and carbon monoxide levels will provide little understanding of the problem. While it is often said that "a model is only as good as its data," an equally true statement may be that "data are only as good as their interpretation". It does not make sense to use an inferior modeling or understanding technique while undertaking an expensive data gathering effort. We propose the following work plan for Phases II and III.

### Phase II

Task I - Data collection and model calibration: In order for a computer model to prove its worth as an operational tool, it must undergo a process of model calibration and verification. In the calibration phase, the coefficients of the model and its relationships for a particular site are verified by comparing the model's prediction of a prototype problem. To be sufficiently understood, such a problem needs to be independently monitored, and an estimation must be made of the

accuracy of the data. Some important topics that must be addressed during data collection include: How accurate does the model need to be? What are its major sources of uncertainty? How can the data collection program improve model accuracy? What form should the data collection take? In practice, data collection related to carbon monoxide in Alaska will probably focus on:

1. Carbon monoxide source emission rates and related traffic patterns.
2. Atmospheric carbon monoxide concentrations used to establish initial conditions and to guide model calibration.
3. Meteorological measurements needed for operating the model--such as wind vectors, inversion layer height, and diffusion coefficients.

#### Task 2 - Refinement of the existing carbon monoxide model:

After the completion of Phase I and the first task of Phase II, a number of desired modifications will be indicated in the existing ACOSP model. For example, input data may be restructured to more easily conform to existing traffic pattern data or to meteorological data and to UTPS format requirements. This task will be an interpretive one in which data review and calibration will take place, so that the final version of the model represents the state of the art for northern urban atmospheric contaminant problems.

#### Task 3 - Training and documentation for model improvement:

This final task of Phase II will update existing documentation and develop new documentation for an ongoing training program for using the calibrated model. This would enable people in Alaska to learn how to use the model for their own air quality problems with a minimum of external assistance. Also, there would be an exploration of additional applications for the model as confidence in the acceptability of the model increases.

#### Phase III

This phase would include a program of improvement, application and training. It is expected that a small continuing program

would be maintained in which the model would be monitored periodically, solutions run, and assistance given in setting up problems and making improvements suggested by continuing experience.

We strongly recommend that the involved agencies and political jurisdictions commit themselves to a program to improve the health of the Alaskan people as it relates to carbon monoxide levels. This program, if undertaken with the current model and its recommended modifications, will better enable these agencies to interpret existing problems, guide future data collection, and develop reaction strategies appropriate to the situation.

It is only through such a concerted effort that the prime goal of the entire program can be achieved.

#### SUMMARY

This project evaluated (1) the state of the art for pollutant transport models and (2) the Alaskan use, experience with, and desire for such a model.

An examination of model types (see RMA report, Appendix I) reveals two basic approaches to atmospheric contaminant transport problems: Gaussian dispersion and conservation of mass. The former is better suited to simpler or more generalized analyses because of assumed nonvariability of environmental parameters. The latter is more computationally complex but allows time variation of parameters.

The conservation of mass models are subdivided into two types, Eulerian and Lagrangian. The first is a "fixed frame" approach, relying on numerical integration routines. The second is a "moving frame" approach, requiring complex bookkeeping algorithms for the many moving particles. The Eulerian model seems to have elements that enhance its reliability as compared to Lagrangian or hybrid models.

Again, there are two approaches to Eulerian conservation of mass modeling: finite element and finite difference. The finite element approach is more adaptable to irregular geometries, and it has a regional orientation that is compatible with input data which may be areally averaged.

From this we can conclude that a more complex and geometrically irregular situation can be modeled best by finite element integration (Eularian) methods applied to conservation of mass theory. ACOSP is such a finite element Eularian conservation of mass model.

The desire of Alaskans for a model such as ACOSP, however, varies from enthusiastic to moderate, varying largely with individuals' conceptions of its applicability to their specific needs. Both offices of DOTPF's Environmental Division were quite positive about a modeling effort. The DOTPF Planning Division offices--who do support work for the Environmental Division in various ways--were less enthusiastic although positive, since they don't see this as their mainline mission. DEC people varied also. The Fairbanks office, which is not intimately and actively involved in the air quality issues, was moderately encouraging. The Anchorage office, which is thoroughly enmeshed with air quality matters there, had definite ideas about what should be in a model, giving guarded encouragement to the further development of ACOSP. The local agencies were definitely interested in a more sophisticated model but, not having considered the ramifications, saw it as a "nice" addition rather than something for which they had a defined need. EPA gave unqualified encouragement. All offices seemed comfortable with locating a model on the UACN's Honeywell computer, and most expressed relief that a simplifying front-end package was being considered, since the use and experience level of the persons who would be assigned to run a program would vary widely.

Besides a front-end package, some internal modifications would increase efficiency, and improvements in output routines (especially simple graphics) would ease interpretation. We are recommending that these be implemented. Data file compatibility with UTPS should be investigated.

Recommendations concerning other aspects of this problem fall into three categories: emissions, meteorology, and health. We recommend that investigation continue regarding cold weather vehicle operation, especially the cold start phenomenon, so that realistic evaluations can be made of emission control devices throughout their operational lives and so that traffic data can be more completely documented. We recommend that meteorological studies be supported, especially those documenting

wind fields, inversion heights, dispersion coefficients, and topographic influences, all within the "living space" of the airshed. We recommend further studies of relationships between CO levels and human health. This has no direct bearing on an atmospheric transport model, but it is the basis for the entire effort and the crux of the matter for public support.

APPENDIX I

EVALUATION OF THE STATE-OF-THE-ART  
OF ATMOSPHERIC CONTAMINANT  
TRANSPORT MODELING

- PHASE I, TASK 2, SUBCONTRACTOR'S REPORT -

Prepared for  
Institute of Water Resources  
University of Alaska  
Fairbanks, Alaska 99701

Prepared by  
Resource Management Associates  
3738 Mt. Diablo Blvd., Suite 200  
Lafayette, CA 94549

RMA 8007  
July, 1980

## TABLE OF CONTENTS

	<u>PAGE</u>
1. INTRODUCTION	I-1
1.1 BACKGROUND AND OBJECTIVES	I-1
1.2 METHODOLOGY	I-2
2. REVIEW OF ATMOSPHERIC DISPERSION MODELING TECHNIQUES	I-6
2.1 GENERAL BACKGROUND	I-6
2.2 GAUSSIAN MODELS	I-7
2.3 CONSERVATION OF MASS APPROACH	I-18
2.4 USING MODELS TO EVALUATE MANAGEMENT ALTERNATIVES	I-27
2.5 MODEL PERFORMANCE AND VALIDATION	I-30
3. COLD REGION CONSIDERATIONS	I-32
3.1 COLD REGION MICROMETEOROLOGY	I-33
3.2 DISPERSION COEFFICIENTS IN COLD REGIONS	I-35
3.3 COLD REGION EFFECTS ON SOURCE EMISSION RATES	I-36
4. CARBON MONOXIDE CONSIDERATIONS	I-38
5. SUMMARY AND CONCLUSIONS	I-41

## LIST OF FIGURES

		<u>PAGE</u>
FIGURE 1-1	ATMOSPHERIC CONTAMINANT LITERATURE CLASSIFICATION SCHEME	I-3
FIGURE 2-1	SCHEMATIC REPRESENTATION OF THE GAUSSIAN PUFF MODEL (Taken from TSC (1972))	I-12
FIGURE 2-2	SCHEMATIC REPRESENTATION OF THE GAUSSIAN PLUME MODEL (Taken from TSC (1972))	I-13
FIGURE 2-3	EULERIAN SPATIAL DISCRETIZATION TECHNIQUES	I-22
FIGURE 2-4	LAGRANGIAN SPATIAL DISCRETIZATION TECHNIQUES	I-24

## LIST OF TABLES

TABLE 2-1	TYPICAL GAUSSIAN ATMOSPHERIC CONTAMINANT MODELS	I-8
TABLE 2-2	TYPICAL CONSERVATION-OF-MASS ATMOSPHERIC CONTAMINANT MODELS	I-10
TABLE 2-3	INPUTS REQUIRED BY A TYPICAL REGIONAL ATMOSPHERIC CONTAMINANT DISPERSION MODEL	I-28

## 1. INTRODUCTION

### 1.1 BACKGROUND AND OBJECTIVES

This report summarizes the results of a state-of-the-art review of atmospheric contaminant transport modeling, with particular emphasis on cold regions and carbon monoxide. The review is part of Task 2 of the first phase of a project being conducted for the Alaskan Department of Transportation and Public Facilities (DOT&PF) by the University of Alaska's Institute of Water Resources (IWR). The project is entitled "Improvement of the Fairbanks' Atmospheric Carbon Monoxide Transport Model - A Program for Calibration, Verification and Implementation" and is described in IWR's proposal No. 80-17 (IWR, 1979).

The results of this state-of-the-art review are intended to evaluate the need for further development and application of a predictive numerical model of carbon monoxide transport called ACOSP (Atmospheric Carbon Monoxide Simulation Program). This model was developed jointly by IWR and Resource Management Associates (RMA) of Lafayette, CA and was delivered to DOT&PF in June, 1976 (see Carlson and Fox, 1976, and Norton and Carlson, 1976). Since the development of ACOSP, there have been advances in atmospheric transport modeling as a result of several large-scale efforts in urban areas of the United States, as well as in other countries containing cold regions (e.g., Canada and northern Europe). Also, computerized bibliographies and literature search capabilities have expanded considerably, making it much easier to locate relevant references and abstracts. For these reasons, we can now construct a comprehensive picture of the state-of-the-art of atmospheric transport modeling which puts ACOSP in proper perspective and identifies technical innovations that may be useful in the Alaskan environment.

Because the literature on air pollution modeling includes tens of thousands of citations, some method for editing available material is needed to provide a manageable and readable review. The procedure we have selected for doing this is described in the next sub-section. The remaining sections of the report summarize various developments in atmospheric transport modeling technology and relate these developments to the needs of DOT&PF. An extensive bibliography is provided at the end of the report for readers wishing to pursue particular subjects in more detail.

## 1.2 METHODOLOGY

Most of the available literature on atmospheric modeling and contaminants is abstracted and indexed in the following computerized data bases:

- NTIS - The National Technical Information Service of the U.S. Department of Commerce
- APTIC - A specialized air pollution index maintained by the Air pollution Technical Information Center and the Franklin Institute
- ENVIROLINE<sup>®</sup> - A specialized environmental index maintained by the Environmental Information Center Inc.
- POLLUTION ABSTRACTS - A pollution-related index maintained by Data Courier, Inc.

Each of these data bases contains many potentially-relevant entries (APTIC alone contains 89,000 entries, all related to atmospheric pollution). To narrow the field of publications to be searched, it is useful to adopt the simple classification scheme illustrated in Figure 1-1.

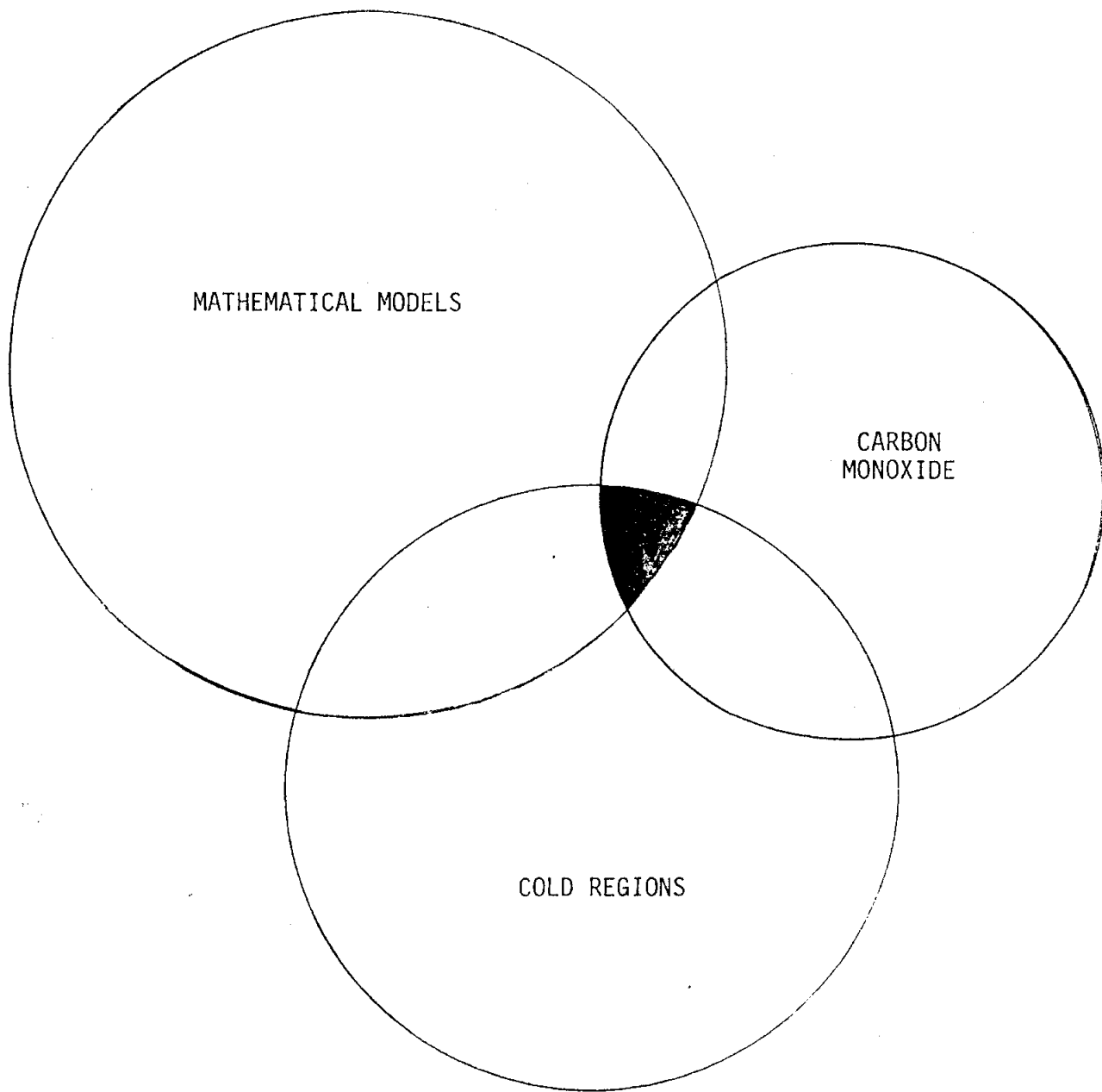

FIGURE 1-1  
ATMOSPHERIC CONTAMINANT LITERATURE  
CLASSIFICATION SCHEME

Each of the circles in Figure 1-1 represents a set of literature citations which relate in some way to atmospheric contaminants. The overlapping areas correspond to citations that are members of two or more sets--i.e., citations that relate to modeling *and* cold regions, modeling *and* carbon monoxide, etc. The following statistics, obtained from the NTIS data base, give some indication of the relative size of the various areas defined in Figure 1-1:

<u>Area</u>	<u>Number of Citations</u>
Mathematical Modeling	67663
Cold Regions	8640
Carbon Monoxide	3330
Carbon Monoxide Modeling	1016
Cold Regions Modeling	824
Carbon Monoxide in Cold Regions	162
Carbon Monoxide Modeling in Cold Regions	5

As might be expected, the number of citations decreases as the topics become more specialized.

Our review is organized around summaries of the literature in each of the three major subject areas identified above--mathematical modeling, carbon monoxide, and cold regions. General conclusions about cold region carbon monoxide modeling can then be developed by referring to the key points made in each of the topical summaries. This approach leads naturally to the division of subject matter provided in the next four sections of this report. Separate sections are devoted to atmospheric modeling techniques, carbon monoxide, and cold region considerations. The most emphasis is placed on the first of these categories since the literature on modeling is the most extensive and the most immediately relevant to the ACOSP modeling project. The last section of the report draws some conclusions about carbon monoxide transport modeling with ACOSP which we believe are supported by the topical summaries.

Our approach to the ACOSP state-of-the-art survey fits in well with modern computerized methods of data retrieval and is readily expanded as more information becomes available. Interested readers should note the annual literature summaries produced by NTIS (see the bibliography) which may be used to periodically update the conclusions of this review. Many other specific references are cited in the examples and tables provided in Sections 2 through 4.

## 2. REVIEW OF ATMOSPHERIC DISPERSION MODELING TECHNIQUES

### 2.1 GENERAL BACKGROUND

Many of the basic concepts of atmospheric dispersion modeling have been in widespread use for many years. A number of excellent discussions of these concepts are available in published surveys and literature reviews. The description of modeling techniques provided in this section relies largely on material presented in TSC (1972), RFF (1979), and Munn (1968).

An atmospheric dispersion model may be defined as a mathematical structure which accepts information on source emissions, meteorological conditions, geographic boundaries, etc., as inputs; computes the dispersion of pollutants by atmospheric processes; and produces output data on the concentration of pollutants over the area of interest for specified time periods. The model is a mechanism for translating emission data into air quality data and, as such, is a valuable tool for environmental impact analysis.

Most available mathematical models of atmospheric contaminant dispersion fall into the following categories:

1. Gaussian models which assume that the movement of pollutants can be represented by a Gaussian dispersion process
2. Conservation of mass models which require the solution of differential equations describing movement by turbulent diffusion and convection
3. Box models which assume that pollutant concentrations are homogeneous throughout a prescribed region (Smith, 1961)
4. Statistical methods which use regression theory to develop an empirical relationship between concentrations and emissions (Croke et. al., 1968)

5. Solutions of Navier-Stokes type equations for turbulent fluid motions. These solutions calculate the field of turbulence, turbulent fluxes, and pollutant dispersion rates, computed from input data on the vertical profiles of temperature and mean wind speed in the atmospheric boundary layer (Donaldson et. al., 1971).

A survey of literature reviews such as TSC (1972), NATO (1977), NATO (1978), indicates that, of these categories, the first two--Gaussian and conservation of mass models--are by far the most frequently used. For this reason the remainder of this section is devoted to a discussion of the major types of Gaussian and conservation of mass models (Sections 2.2 and 2.3, respectively). Representative examples of these two model categories are listed in Tables 2-1 and 2-2. The models chosen for inclusion in the tables were picked either because they are widely used, because they have been applied in a major urban region, or because they are potentially relevant to the Alaskan environment. Readers interested in more extensive lists of available simulation models should refer to the bibliographies listed at the end of this report.

## 2.2 GAUSSIAN MODELS

Gaussian techniques for modeling the dispersion of pollutants in the atmosphere, based upon the pioneering work of Taylor (1922) and Sutton (1932) as later developed by Cramer (1957), Pasquill (1961) and Guifford (1961), are quite widely used because of their simplicity and intuitive appeal. In this sub-section the various Gaussian equations are stated; methods of solution are discussed; and the limitations of these equations are examined.

TABLE 2-1

TYPICAL GAUSSIAN ATMOSPHERIC  
CONTAMINANT MODELS  
(All models except Argonne Puff  
and SRI are steady-state)

MODEL NAME/ACRONYM	ORIGINATOR/CONTACT	CONSTITUENTS	SOURCES	SPACE SCALE FOR TYPICAL APPLICATIONS
Air Quality Display Model/AQDM	TRW Systems Group under contract to National Air Pollution Control Admin (presently EPA), Mr. Bruce Turner, Contract Officer	SO <sub>2</sub> and suspended particulates	General	Up to 50 km
Climatological Display Model/CDM	Meteorology Lab, EPA Research Triangle Park, NC (UNAMAP series)	SO <sub>2</sub> and suspended particulates	General	Up to 50 km
Air Quality Submodel of the Transportation & Air Shed Simulation Model	Norm Cooper, Office of Environmental Affairs, US Dept of Transportation, Washington, D.C.	SO <sub>2</sub> , particulates, NO <sub>x</sub> , HC <sub>x</sub> , CO, metals	General	Up to 50 km
COPLLUT	C.R. Gebhardt, Ohio Dept of Transportation, Columbus, Ohio	CO	Line	Less than 3 km
California Line Source Dispersion Model/CALINE 2	Mr. Andy Ranzieri, Calif State Div of Highways, Sacramento, CA	NO <sub>x</sub> , HC <sub>x</sub> , and CO	Line and area	Less than 3 km
EPA HIWAY/HIWAY	Meteorology Lab, EPA, Research Triangle Park, NC (UNAMAP series)	NO <sub>x</sub> , HC <sub>x</sub> , CO, metals	Line	Less than 3 km
Point, Area, Line Source Model/PAL	Bruce Turner & William B. Petersen, Meteorology Lab, EPA, Research Triangle Park, NC	SO <sub>2</sub> , particulates, NO <sub>x</sub> , HC <sub>x</sub> , CO, metals	General	Less than 3 km
Single Source Model/CRSTER	Russell Lee et al, Source Receptor Analysis Branch, Office of Air Quality Planning & Standards, EPA, Durham, NC	SO <sub>2</sub> , particulates, NO <sub>x</sub> , metals	Point	Up to 50 km
Air Pollution Research Advisory Committee/APRAC IA	R.C. Manusco & F.L. Ludwig, Stanford research Inst, Menlo Park, CA (UNAMAP series)	CO	Line and area	Up to 200 km
PTMAX/PTMAX	Meteorology Lab, EPA, User Network of Applied Models of Air Pollution (UNAMAP series)	SO <sub>2</sub> , particulates, NO <sub>x</sub> , HC <sub>x</sub> , CO, metals	Point	Up to 50 km
PTDIS/PTDIS	Meteorology Lab, EPA, User Network of Applied Models of Air Pollution (UNAMAP series)	SO <sub>2</sub> , particulates, NO <sub>x</sub> , HC <sub>x</sub> , CO, metals	Point	Up to 50 km

TABLE 2-1  
(continued)

PTMTP/PTMTP	Meteorology Lab, EPA, User Network of Applied Models of Air Pollution (UNAMAP series)	SO <sub>2</sub> , particulates, NO <sub>x</sub> , HC <sub>x</sub> , CO, metals	Multi-point	Up to 50 km
Real-Time Air Pollution Model/RAM	B. Turner & J. Novak, Meteorology Lab, EPA, Research Triangle Park, NC (to be included in UNAMAP series)	SO <sub>2</sub> , particulates, NO <sub>x</sub> , HC <sub>x</sub> , CO, metals	General	Up to 50 km
Gaussian Evaluation Model/GEM	A. Fabrick, R. Sklarew, J. Wilson, Science Applications, Westlake Village, CA	SO <sub>2</sub> , particulates and NO <sub>x</sub>	Multi-point	Up to 50 km
Argonne Puff	E.J. Croke, J.J. Roberts, et al, Energy & Environmental Div, Argonne National Lab, Argonne, IL	SO <sub>2</sub> and particulates	General	Up to 50 km
Stanford Research Inst/SRI	R. Ruff, Stanford Research Inst, Palo Alto, CA	SO <sub>2</sub> , particulates and NO <sub>x</sub>	Multi-point	Up to 50 km
VALLEY	E. Burt, Source Receptor & Analysis Branch, Office of Air Quality Planning & Standards, EPA, Durham, NC	SO <sub>2</sub> , particulates and NO <sub>x</sub>	General	Up to 50 km
Oak Ridge Fog & Drift/ORFAD	J. Wilson, Oak Ridge Natl Lab, Oak Ridge, TN	Salts	Point	Less than 3 km
Atmospheric Transport Model	W. Culkowski & M. Patterson, Oak Ridge Natl Lab, Oak Ridge, TN	SO <sub>2</sub> , particulates, metals, salts, radioactivity	General	Up to 50 km
Drift Transport Cooling Tower	G. Schrecker, Environmental Systems Corp, Knoxville, TN	Toxic metals	Point	Up to 50 km
Texas Episodic Model/TEM	J. Christiansen, Data Processing Div, Texas Air Control Board, Houston, TX	SO <sub>2</sub> , particulates, NO <sub>x</sub> , HC <sub>x</sub> , CO	General	Up to 50 km
Texas Climatological Model/TCM	J. Christiansen, Data Processing Div, Texas Air Control Board, Houston, TX	SO <sub>2</sub> , particulates, NO <sub>x</sub> , HC <sub>x</sub> , CO	General	Up to 50 km

TABLE 2-2

TYPICAL CONSERVATION-OF-MASS ATMOSPHERIC  
CONTAMINANT MODELS  
(all models are dynamic)

MODEL NAME/ACRONYM	ORIGINATOR/CONTACT	CONSTITUENTS	SOURCES	SPACE SCALE FOR TYPICAL APPLICATIONS
International Business Machines Air Quality 1&2/IBMAQ 1&2	D. Shieh, Int'l Business Machines, San Jose, CA	SO <sub>2</sub> and suspended particulates	General	Up to 50 km
INTERA/INTERA	R. Lantz, INTERA, Environmental Consultants, Houston, TX	SO <sub>2</sub> , particulates, NO <sub>x</sub> and HC <sub>x</sub>	General	Up to 50 km
Atmospheric Diffusion Particle-In-Cell/ADPIC	M. MacCracken & R. Lange, Lawrence Livermore Lab, Livermore, CA	SO <sub>2</sub> , particulates and NO <sub>x</sub>	Line and area	Up to 50 km
Atmospheric Carbon Monoxide Simulation Program/ACSOP	R. Carlson & W. Norton, Univ of Alaska, Fairbanks, Alaska	CO	General	Up to 50 km
Livermore Regional Air Quality I/ LIRAQ I	M. MacCracken, Lawrence Livermore Lab, Livermore, CA	SO <sub>2</sub> and CO	General	Up to 200 km
Livermore Regional Air Quality II/ LIRAQ II	M. MacCracken, Lawrence Livermore Lab, Livermore, CA	SO <sub>2</sub> , NO <sub>x</sub> , HC <sub>x</sub> , CO and oxidants	General	Up to 50 km
Reactive Plume Model/RPM	Mei-Kao-Liu, Systems Applications, San Rafael, CA	SO <sub>2</sub> and NO <sub>x</sub>	General	Between 3 and 50 km
Integrated Model for Plume & Atmospheric in Complex Terrain/ IMPACT	A. Fabrick, R. Sklarew, J. Wilson, Science Applications, Westlake Village, CA	SO <sub>2</sub> , particulates, NO <sub>x</sub> , HC <sub>x</sub> and oxidants	General	Up to 50 km
Westinghouse Cooling Tower	A. Roffman & R. Grimble, Env Systems Dept, Westinghouse Electric Corp, Santa Monica, CA	Toxic metals	General	Up to 50 km
Reactive Environmental Simulation Model/REM & REM 2	P. Drivas, Pac Env Services, Inc., Santa Monica, CA	NO <sub>x</sub> , HC <sub>x</sub> , CO and oxidants	General	Between 3 and 50 km
Diffusion Kinetics Model/DIFKIN	A. Eschenroeder, Env Research & Tech, Inc, Santa Barbara, CA	NO <sub>x</sub> , HC <sub>x</sub> and oxidants	General	Up to 50 km
Center for the Environment & Man/ CEM	J. Pandolfo, Center for the Env & Man, Hartford, Conn.	SO <sub>2</sub> , particulates, NO <sub>x</sub> and CO	General	Up to 50 km
Systems Application, Inc. Photochemical/SAI	S. Reynolds & P. Roth, Systems Applications, San Rafael, CA	SO <sub>2</sub> , particulates, NO <sub>x</sub> , HC <sub>x</sub> , CO and oxidants	General	Up to 200 km
Numerical Examination of Urban Smog/HEXUS	R. Sklarew, A. Fabrick, J. Prager, Systems, Science & Software, La Jolla, CA	SO <sub>2</sub> , particulates, NO <sub>x</sub> , HC <sub>x</sub> , CO and oxidants	General	Up to 50 km

### 2.2.1 The Gaussian Puff Model

The Gaussian Puff equation is considered first since all other Gaussian equations can be derived from it. This equation deals with the instantaneous emission of a finite puff of material from a point source at height H. The concentration,  $C(x,y,z,t)$ , of material is expressed by the equation:

$$C(x,y,z,t) = \frac{Q}{(2\pi)^{3/2} \sigma_x \sigma_y \sigma_z} \exp - \left[ \frac{(x-\bar{u}t)^2}{2\sigma_x^2} + \frac{y^2}{2\sigma_y^2} \right] \cdot \left\{ \exp - \left[ \frac{(z-H)^2}{2\sigma_z^2} \right] + \exp - \left[ \frac{(z+H)^2}{2\sigma_z^2} \right] \right\} \quad (2-1)$$

where  $Q$  = amount of material emitted (mass units)

$x,y,z$  = Cartesian coordinates with positive  $x$  being the downwind direction

$t$  = time since emission of the puff

$\bar{u}$  = mean wind transporting the material in the  $x$  direction

$\sigma_x, \sigma_y, \sigma_z$  = standard deviations of the material concentration distribution in the three coordinate directions relative to the puff center with origin ( $\bar{u}t, 0, H$ )

Figure 2-1 shows a conceptual sketch of the Gaussian puff model. Note the Gaussian character of the component distributions of pollutant material.

### 2.2.2 The Gaussian Plume Model

Continuous emission from a point source may be regarded as an infinite series of puffs which spread out into a continuous plume (see Figure 2-2). Thus, the Gaussian Plume equation is the steady state version of the Gaussian Puff equation and is derivable by integrating Equation 2-1 with respect to time and keeping  $\sigma_x$  constant as the puff passes any point:

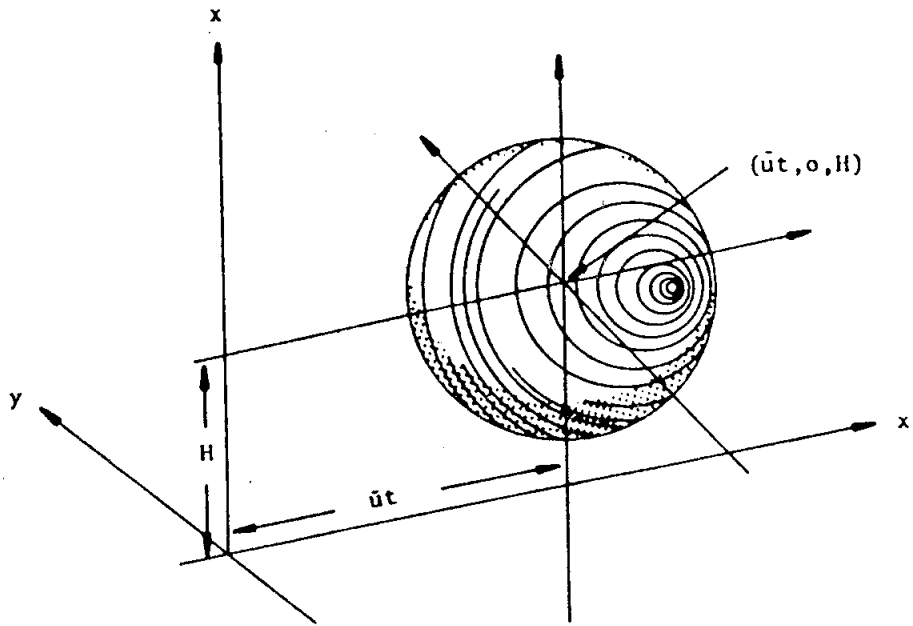

A. Three Dimensional Puff of Material

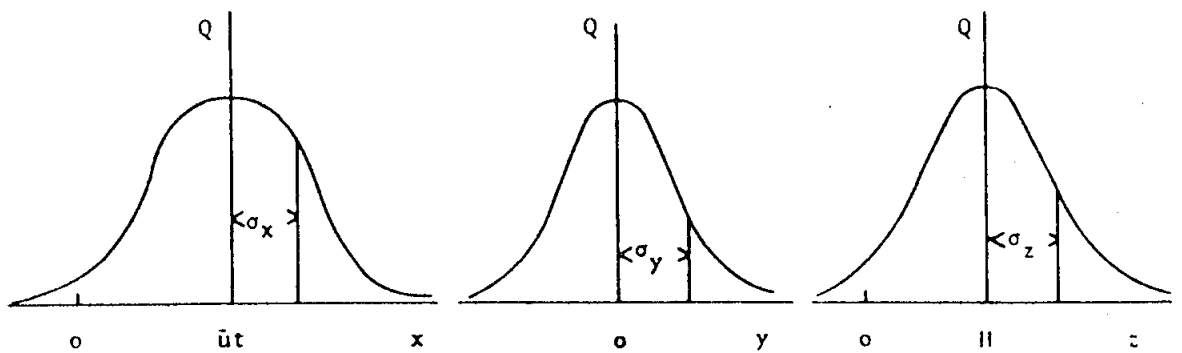

B. Component Distributions of Material about Axes through  $(\bar{u}t, 0, H)$

FIGURE 2-1

SCHEMATIC REPRESENTATION OF THE GAUSSIAN PUFF MODEL  
(Taken from TSC (1972))

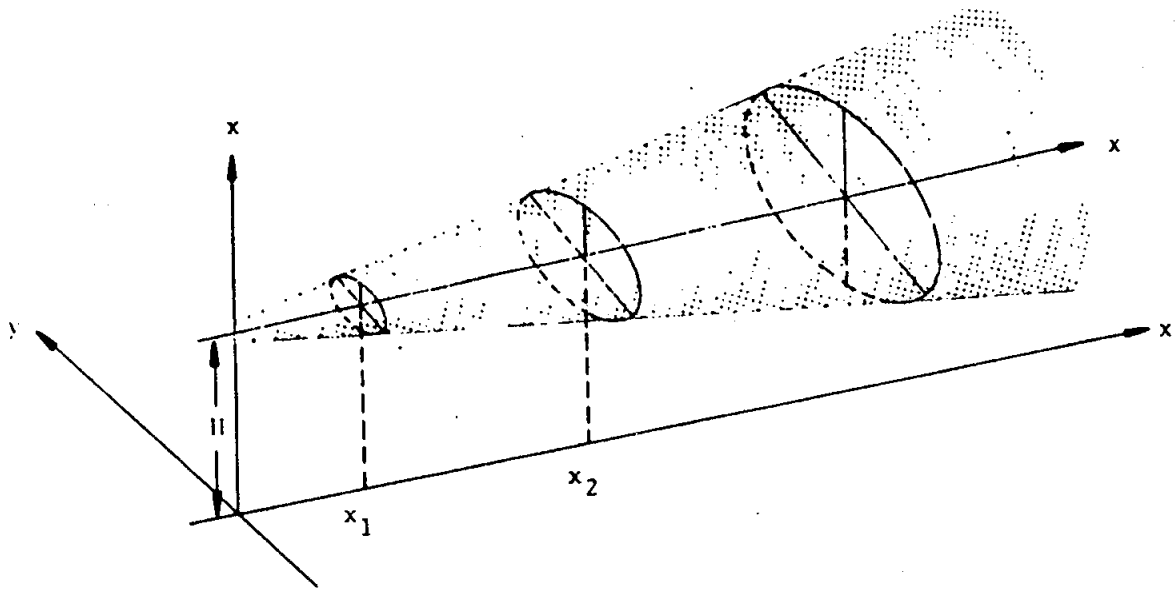

A. Three Dimensional Plume of Material

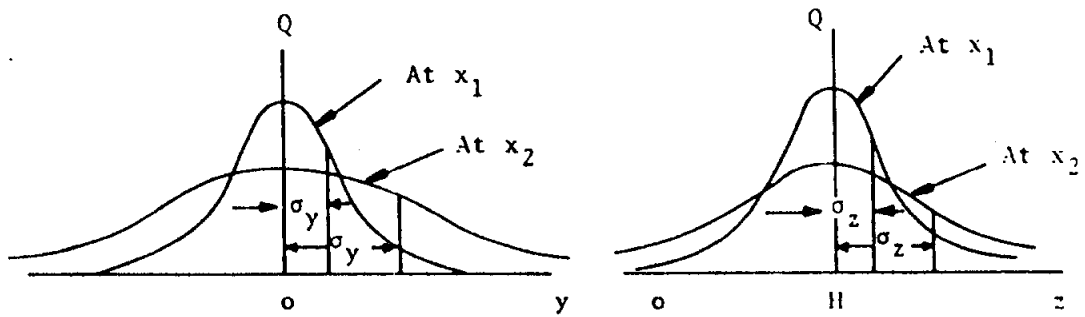

B. Component Distribution of Material About  $(x_1, 0, H)$  and  $(x_2, 0, H)$

FIGURE 2-2

SCHEMATIC REPRESENTATION OF THE GAUSSIAN PLUME MODEL  
(Taken from TSC(1972))

$$\begin{aligned}
C(x,y,z) &= \int_{-\infty}^{\infty} X_1(x,y,z,t) dt \\
&= \frac{Q}{2\pi\sigma_y\sigma_z\bar{u}} \exp - \left[ \frac{y^2}{2\sigma_y^2} \right] \\
&\quad \cdot \left\{ \exp - \left[ \frac{(z-H)^2}{2\sigma_z^2} \right] + \exp - \left[ \frac{(z+H)^2}{2\sigma_z^2} \right] \right\} \quad (2-2)
\end{aligned}$$

where  $Q$  = the source emission rate of material (mass time<sup>-1</sup>)

$x$  = the downwind direction along the plume axis

$\sigma_y, \sigma_z$  = standard deviations of the material concentration distribution in the  $y$  and  $z$  directions relative to the plume axis

Other terms are as previously defined. The Gaussian Plume equation can also be modified to handle both line and area sources as shown below.

### 2.2.3 The Gaussian Line Source Models

Consider a finite line at height  $H$  extending from  $y_1$  to  $y_2$ ,  $y_1 < y_2$ , perpendicular to the mean wind which blows in the  $x$  direction. The line emits at a constant rate,  $q$ , per unit length (mass time<sup>-1</sup> distance<sup>-1</sup>).

Then:

$$C(x,y,0) = \frac{2q}{\sqrt{2\pi}\sigma_z\bar{u}} \exp - \left[ 1/2 \left( \frac{H}{\sigma_z} \right)^2 \right] \int_{P_1}^{P_2} \frac{1}{\sqrt{2\pi}} \exp - \left( \frac{p^2}{2} \right) dp \quad (2-3)$$

where  $P_i = \frac{y_i}{\sigma_y}$ ,  $i=1,2$

All other terms are as previously defined.

If the finite line source is on the ground, as would be the case for a road or airport runway, then:

$$C(x,y,0) = \frac{2q}{\sqrt{2\pi} \sigma_z \bar{u}} \int_{P_1}^{P_2} \frac{1}{\sqrt{2\pi}} \exp - \left( \frac{p^2}{2} \right) dp \quad (2-4)$$

If the line is of infinite length,

$$C(x,y,0) = \frac{2q}{\sqrt{2\pi} \sigma_z \bar{u}} \exp - \left[ 1/2 \left( \frac{H}{\sigma_z} \right)^2 \right] \quad (2-5)$$

If the infinite line is on the ground, there results the simple form:

$$C(x,y,0) = \frac{2q}{\sqrt{2\pi} \sigma_z \bar{u}} \quad (2-6)$$

#### 2.2.4 The Gaussian Area Source Model

An area may be treated as a cross-wind line source with a normal distribution of material,  $\sigma_y$ . The area source is assumed to have an initial standard deviation,  $\sigma_{y0}$ . The area can be treated using Equation (2-2) by defining a virtual upwind distance for a point source which would produce the desired  $\sigma_{y0}$  at the initial position of the area source. The initial vertical variation of emissions due to the distribution of source heights is represented by an initial  $\sigma_{z0}$  which can also be handled by defining an upwind virtual point source at the proper distance.

#### 2.2.5 Solution of the Gaussian Equations

The Gaussian equations are receptor oriented, which is to say that they are best suited to computing the concentrations of pollutants at specific locations due to emissions from a given source. The principle of superposition is used to compute the concentration at a receptor of pollutants from multiple sources. If the number of source/receptor combina-

tions is small, the equation can readily be solved using the graphs and nomograms in the reports by Turner (1971) and Beals (1971). On the other hand, large dispersion problems, involving multiple sources and many receptors, must be solved on a digital computer. If concentrations at a large number of receptors are required, the computation time can be reduced by calculating backward trajectories from each receptor and then determining the appropriate weighted contribution of all sources along that trajectory during the time period in question.

#### 2.2.6 Advantages and Limitations of the Gaussian Models

The principle advantages of the Gaussian approach to dispersion modeling are its computational simplicity and intuitive appeal. Equations (2-1) through (2-6) are all *explicit* scalar equations for the unknown atmospheric concentration  $C$  (i.e.,  $C$  appears only on the left-hand side of a single equation). This means that complex iterative numerical methods are not required to obtain the contaminant concentration at a particular location and time. Unfortunately, this simplicity has been achieved at the expense of assumptions which restrict the application of Gaussian models in some important real-world dispersion problems. Some of these assumptions and the resulting limitations are briefly discussed below.

First, although the downwind dimension  $x$  does not appear in Equation 2-2,  $C$  is a function of  $x$ ,  $y$  and  $z$ . This is because the equation is derived in such a way that both  $\sigma_y$  and  $\sigma_z$  are functions of  $x$ , hence the dimension  $x$  is implicit. In turn,  $\sigma_y$  and  $\sigma_z$  are functions of atmospheric turbulence, topographic characteristics, wind speed, and other variables. In order to solve the equations, these complex dependencies must somehow be taken into account. The standard approach has been to define a set of five atmospheric stability classes in terms of quantities which are readily observable, namely surface wind speed and incoming solar radiation for daytime situations and surface wind and degree of cloudiness for the night. For each stability class,  $\sigma_y(x)$  and  $\sigma_z(x)$  have been determined empirically. These relationships have been developed for a sampling

of ten minutes in the lower several hundred meters of the atmosphere over flat terrain; their use under other conditions, though frequently undertaken, is questionable.

The Equations 2-2 through 2-6 apply only to the continuous emission from a source, be it a point, line, or area. Also, dispersion in the downwind direction  $x$  is neglected. Therefore, the equations in their original form are not strictly applicable to many real-world problems, especially those involving transportation sources which tend to vary in both space and time. Furthermore, the equations deal only with the diffusion of stable gases or aerosols (i.e., particles of  $<20\mu$  diameter) which are assumed to remain suspended in the atmosphere indefinitely. Hence photochemical reactions are not considered. In addition, since mass continuity is maintained, the Gaussian equations require that no material be removed from the plume as it moves downwind (i.e., total reflection of the plume takes place at the earth's surface).

The requirement that a single wind speed over the entire three dimensional area of concern be used to transport the emitted material is contrary to the known behavior of winds. In fact, it is known that the wind generally increases with height in the lower several hundred meters of the atmosphere, and the use of a mean wind speed will tend to result in an underestimate of concentrations at lower levels and an overestimate at higher levels. Also, since  $\bar{u}$  appears in the denominator of Equations 2-2 through 2-6, it is apparent that all of these equations become unstable in the case of very light or calm winds.

Problems are posed by the existence of a temperature inversion, or stable layer, in the atmosphere which prevents the upward spread of pollutants. The region below such an inversion is called the mixing layer (since, in general, the atmosphere is completely mixed by turbulence in such a layer) and the inversion is called the mixing level. When such conditions exist, the equations must be modified in such a way that the plume material distribution in the vertical becomes uniform at a certain distance downwind from the point where the plume encounters the mixing level. The distribution in the horizontal remains Gaussian.

Although the criticisms of Gaussian dispersion modeling outlined above are significant, it should be pointed out that these models can still be useful in practical applications where the accuracy they provide is sufficient for supporting policy decisions or comparison of alternatives. For example, environmental impact statements must often be completed within short time spans and limited budgets which preclude sophisticated modeling efforts. In such cases, the approximate results provided by an inexpensive and easily used Gaussian plume model may be sufficient to indicate whether or not a particular policy will have significant environmental impacts. It should also be noted that many investigators have dealt with one or more of the limitations of the Gaussian approach by introducing *ad hoc* modifications to the Gaussian model equations. Several of these modifications and improvements are described in the publications listed in Table 2-1. These publications should be consulted by readers interested in possible application of the Gaussian approach.

### 2.3 CONSERVATION OF MASS APPROACH

The conservation of mass approach, as the name applies, is based on the physical principle that total mass is conserved during atmospheric dispersion of contaminants. This implies that the concentration (or mass per unit volume) at any point in the atmosphere can be calculated by keeping track of all the mass entering and leaving the region of interest. Since the modeler is generally concerned with the mass (or concentration) of a particular chemical constituent, the mass sources and sinks considered in a conservation of mass model must include reactive chemical changes (for example, oxidation of NO to NO<sub>2</sub>, which is a source for NO<sub>2</sub> and a sink for NO).

The movement of contaminant particles from point-to-point in the atmosphere is generally divided into two types--advection and dispersion (sometimes called diffusion). Precise definitions of these terms vary but usually advection refers to mean or macroscopic movements and dispersion refers to random or turbulent movements. In practice, the distinction made between mean and random movements must depend on the temporal and spatial

resolution of the model. If the modeler is able to describe the atmospheric velocity field in great detail then advective transport will be more important than dispersive transport. As the model becomes more aggregated, dispersive effects must be relied upon to a greater extent in order to explain observed behavior.

There are two broad approaches for applying conservation of mass principles to atmospheric contaminant transport problems--the Eulerian, or fixed frame-of-reference, approach and the Lagrangian, or moving frame-of-reference, approach. Each of these is discussed in one of the following subsections.

### 2.3.1 Eulerian Models

Eulerian models, of which ACOSP is an example, are based on the well known advection-dispersion partial differential equation. This equation may be derived by applying the conservation-of-mass principle to a control volume fixed in space which experiences a flux of particles moving through it. As the control volume shrinks to a single point (x,y,z), the concentration  $C_i$  of chemical constituent  $i$  at that point is given by:

$$\frac{\partial C_i}{\partial t} = - \nabla \cdot (VC_i) - \nabla \cdot D_i + R_i + S_i \quad (2-7)$$

where  $\nabla$  = vector differential operator having components  $\partial/\partial x$ ,  $\partial/\partial y$  and  $\partial/\partial z$

$V$  = vector wind velocity having components  $V_x$ ,  $V_y$  and  $V_z$

$t$  = time

$D_i$  = vector diffusive flux (mass flux of constituent  $i$  relative to  $V$ ) having components  $D_{ix}$ ,  $D_{iy}$  and  $D_{iz}$

$R_i$  = net source rate of constituent  $i$  due to chemical reactions

$S_i$  = net emission source rate of constituent  $i$

In general,  $C_i$ ,  $V$ ,  $D_i$ ,  $R_i$  and  $S_i$  are all functions of the spatial coordinates  $x$ ,  $y$  and  $z$ .

In most applications, it is assumed that the diffusive flux obeys Fick's law, i.e., the flux is directly proportional to the concentration gradient:

$$D_i = - K_i \nabla C_i \quad (2-8)$$

where  $K_i$  = the dispersion (or diffusion) coefficient

In general,  $K_i$  is a tensor which may be expressed as a 3x3 matrix of nine distinct coefficients. This representation is needed to account for *anisotropic* situations in which the relationship between the concentration gradient and diffusive flux is directionally dependent. In most air pollution applications, it is appropriate to assume that the  $K_i$  matrix is diagonal (as ACOSP does). Further details on this subject are available in Bird et. al. (1960) and other classical references on dispersive transport.

When Equations (2-7) and (2-8) are combined the familiar advection-dispersion transport equation results:

$$\frac{\partial C_i}{\partial t} = - \nabla \cdot (VC_i) + \nabla \cdot (K_i \nabla C_i) + R_i + S_i \quad (2-9)$$

This equation, unlike the Gaussian equations in Section 2.2, does not provide an explicit expression for the concentration  $C_i$ . The equation must be solved for  $C_i$  by integrating it over both time and space, applying appropriate initial conditions for the temporal integration and boundary conditions for the spatial integration. Since analytical integration of Equation (2-9) is possible only in simple situations (e.g., radially symmetric homogeneous systems with constant point sources), numerical integration is used in most practical applications. The commonly used methods for integrating Equation (2-9) fall into two categories--finite difference techniques and finite element techniques.

Finite difference methods approximate partial derivatives such as  $\partial C_i / \partial t$  or  $\nabla C_i$  by ratios of small differences in the dependent and independent variables. In applications with more than one spatial dimension, the spatial differences are based on concentration values defined at the

nodes of a rectangular grid extending over the region of interest (see Figure 2-3a). When all the temporal and spatial derivatives are approximated, Equation (2-9) may be transformed into a set of simultaneous linear algebraic equations in the unknown nodal concentrations. This set of equations is solved recursively from one time step to the next.

Finite element methods use a somewhat different philosophy of numerical integration which is based on the assumption that the solution to Equation (2-9) can be approximated by a series of mathematically simple *shape functions* (e.g., low-order polynomials). Each shape function is defined over a region called an element which is analogous to one of the rectangular members of the finite difference grid. The finite-element discretization scheme is quite general and flexible and may include elements with curved sides (see Figure 2-3b). This is particularly useful when the boundary conditions of Equation (2-9) are most conveniently defined over irregularly shaped surfaces or lines. Once the finite element discretization technique is applied, Equation (2-9) may be transformed into a set of simultaneous linear algebraic equations just as is done with finite difference methods.

The above discussion indicates that Eulerian atmospheric transport models must employ fairly sophisticated numerical procedures to produce accurate and stable concentration profiles throughout the region and time period of interest. This is a significant contrast to the Gaussian approach, in which the relationship between model inputs and model predictions is much more readily apparent. The Lagrangian models described in the next section are more straightforward than Eulerian models from a conceptual point-of-view but, as we shall see, their practical implementation can require computer programs of comparable complexity.

### 2.3.2 Lagrangian Models

As mentioned earlier, Eulerian dispersion models apply the conservation of mass principle to a control volume fixed at a single point in space. Lagrangian dispersion models, on the other hand, apply conservation

Partial derivatives are approximated by differencing concentration values at adjacent nodes

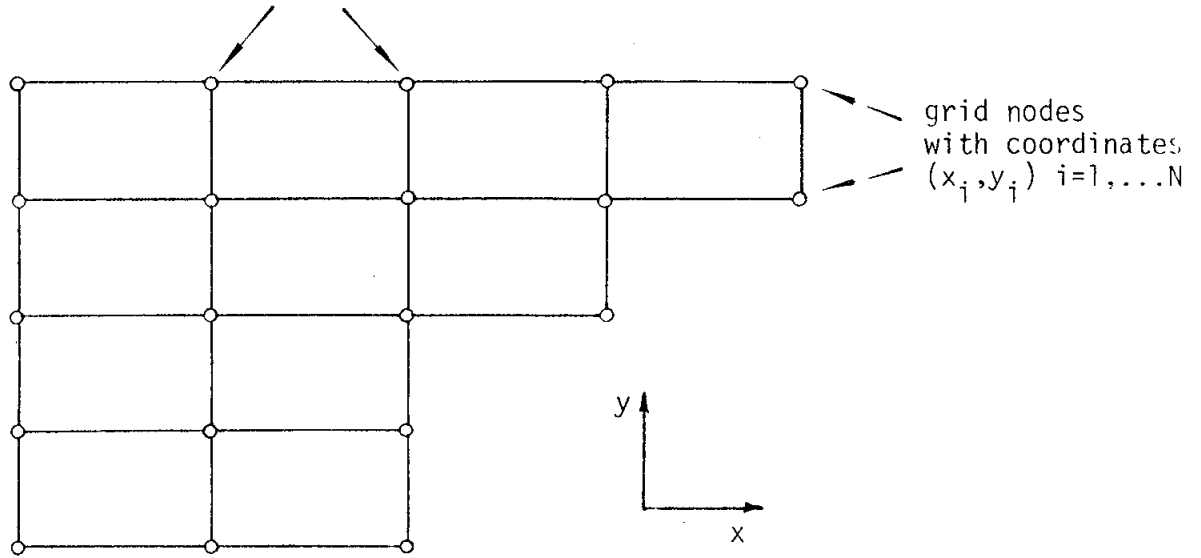

a) Finite Difference Grid

shape functions approximate concentration solution over individual network elements

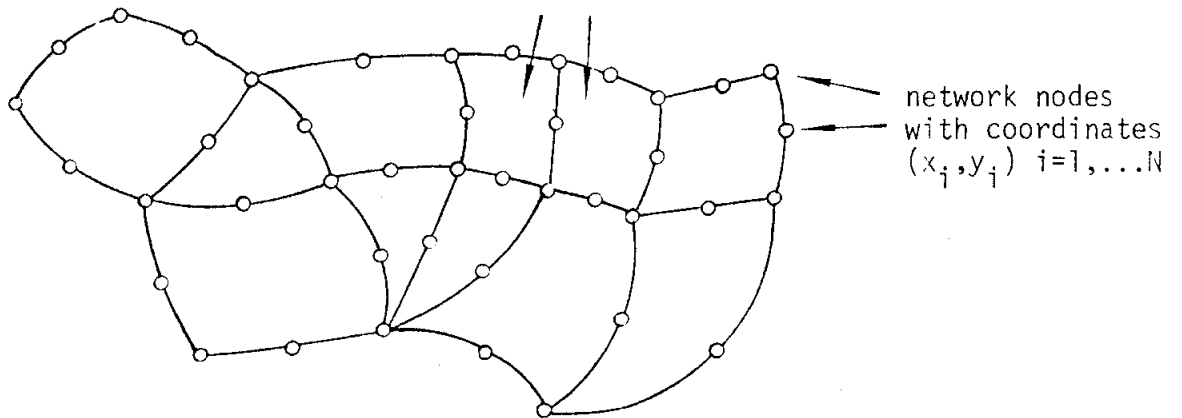

b) Finite Element Network

FIGURE 2-3

EULERIAN SPATIAL DISCRETIZATION TECHNIQUES

of mass to many control volumes which each move with discrete parcels of the dispersing contaminant. This shift in viewpoint is convenient in that it allows the behavior of each individual parcel to be described fairly simply. There are, however, many particles to keep track of, so the complete model can still be mathematically complex.

A number of different Lagrangian approaches to dispersion modeling have appeared in the air and water resources literature. For present purposes, these may be conveniently classified into concentration-oriented particle-in-cell (PIC) techniques and mass-oriented discrete parcel (DP) techniques. This classification is, however, somewhat arbitrary since nearly every Lagrangian model has unique aspects which make it difficult to categorize. Some of these models include random number generators which result in quasi-random concentration outputs, others are purely deterministic. Also, many of the models incorporate Eulerian concepts at some stage and are, therefore, actually hybrids.

Particle-in-cell Lagrangian models are typified by the groundwater dispersion model of Pinder and Cooper (1970) and the hybrid atmospheric dispersion model of Knox (1973). In each case, the model simulation is begun with a number of discrete particles distributed uniformly over a rectangular (Eulerian) grid which is fixed in space (see Figure 2-4a). Each particle is assigned an initial concentration in a manner analogous to the assignment of initial nodal concentrations in the Eulerian formulation of Equation 2-9. The coordinates of the particle are noted and then updated recursively as it moves through the grid. The updates depend, of course, on the local fluid velocities as indicated by the following equation:

$$x_{i+1,r} = x_{i,r} + V_{ix} \Delta t_i \quad (2-10)$$

where  $x_i, x_{i+1}$  = vector coordinates of particle  $r$  at times  $t_i$  and  $t_{i+1}$ , respectively

$V_{ix}$  = velocity in the vicinity of  $x_{i,r}$  at time  $t_i$

$\Delta t_i = t_{i+1} - t_i$

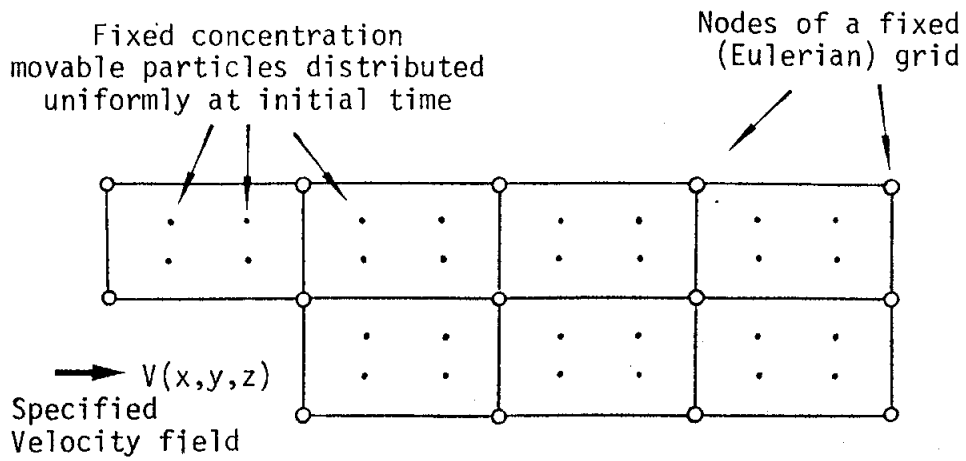

a) Particle-in-Cell Grid

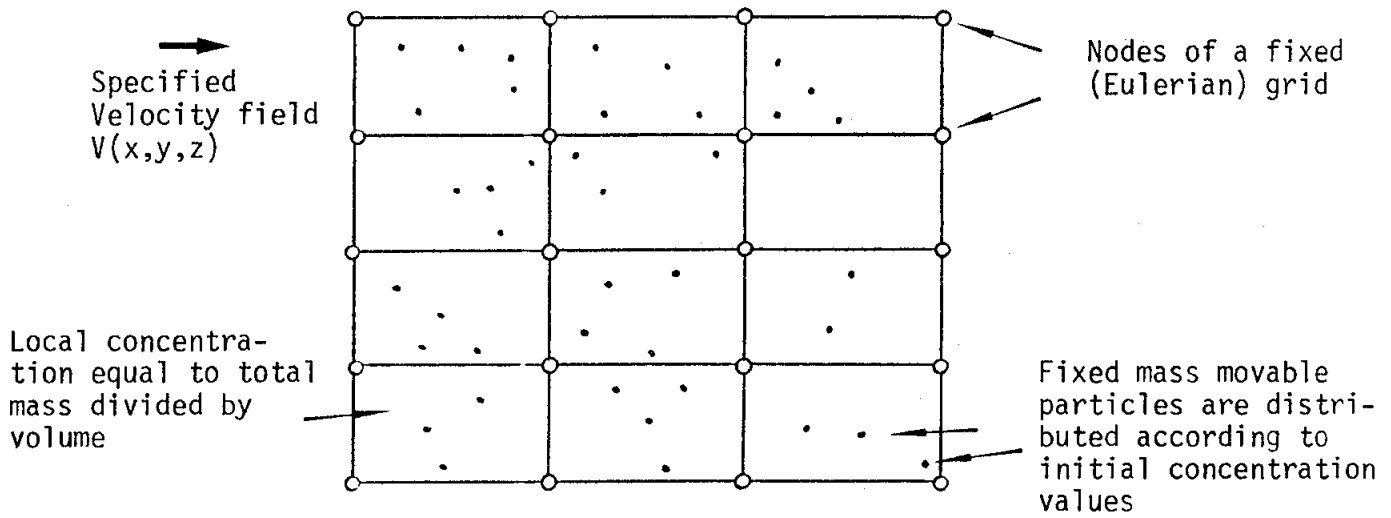

b) Discrete Parcel Grid

FIGURE 2-4

LAGRANGIAN SPATIAL DISCRETIZATION TECHNIQUES

Various techniques are used to compute  $V_{ix}$  from available velocity data, some designed to include turbulent dispersive effects.

Once the particles are moved according to Equation (2-10), their concentrations are modified to account for their relative dispersion or concentration. This requires the model to compute concentrations at the fixed grid points from, for example, averages of the particle concentrations within each grid cell. These grid concentrations are generally the quantities output to the user. The reason usually given for using this approach is that it avoids so-called "numerical dispersion," an artificial smoothing of dispersing wave fronts caused by the approximations adopted in Eulerian methods. Although the PIC method does not have numerical dispersion, it appears to have troubles conserving mass and, furthermore, it tends to require many particles to give reasonable accuracy (Ahlstrom et. al., 1977).

Discrete parcel Lagrangian models circumvent the mass balance problems of PIC models by assigning a mass value, rather than a concentration, to each moving particle (or parcel). The particles are transported using Equation (2-10) and local concentrations are computed by simply dividing the total mass in any region by the region's volume (see Figure 2-4b). Ahlstrom et. al. (1977) partition  $V_{ix}$  into deterministic and random components as follows:

$$V_{ix} = \bar{V}_{ix} + \delta V_{ix} \quad (2-11)$$

where  $\bar{V}_{ix}$  = average fluid velocity (input)

$\delta V_{ix}$  = turbulent fluid velocity (provided by a pseudo-random number generator in the model's computer program)

The use of a random number generator provides intuitively appealing particle trajectories which drift in "random walks" as they move through space. If enough particles are used the average concentration over a sufficiently large region behaves stably and faithfully reproduces analytical solutions for simple geometries. The method is, however, computationally demanding and probably the most costly of the modeling approaches described here.

### 2.3.3 Advantages and Limitations of the Conservation of Mass Approach

The most obvious advantage of the conservation of mass approach to dispersion modeling is its generality. It is not restricted by the rather unrealistic assumptions made in the Gaussian approach and it may be readily adapted to the complex three-dimensional time-varying situations encountered in real-world transportation analyses. The input requirements of conservation of mass and Gaussian models are rather similar. Both require specifications of emission rates (at points, along lines, over areas, etc.), average wind speeds, and random dispersion characteristics (either the standard deviations  $\sigma_x$ ,  $\sigma_y$ , and  $\sigma_z$  on the dispersion tensor  $K_j$ ). The only significant disadvantage of the conservation of mass approach, when compared to Gaussian methods, is its computational complexity. Conservation of mass models must either include numerical integration routines (for Eulerian models) or complex book-keeping algorithms (for Lagrangian models). This requires more computer programming during development and, generally, more computer resources during application.

On the balance, it appears that the flexibility, accuracy, and usefulness of the conservation of mass approach outweigh its computational disadvantages. This conclusion is supported by a number of literature reviews, including TSC (1972) and RFF (1979). Although Gaussian models may give results nearly as good as conservation of mass models in some specialized applications (e.g., ground concentrations downwind of a point source in a coastal environment with steady on-shore winds), they cannot compete in regional applications with many moving sources and time-varying meteorological conditions. The success of ACOSP's preliminary application to the Fairbanks, Alaska airshed is a good example of the flexibility and convenience of the conservation of mass approach.

The relative advantages of Eulerian and Lagrangian methods may be judged partly by their relative frequency of use. Eulerian models are much more common in both air and water resource applications. Although numerical dispersion can be a problem on occasion, it is rarely severe enough to justify sacrificing the other advantages of the Eulerian viewpoint.

Lagrangian models have their own inaccuracies (largely related to the limited number of particles used to describe what is effectively a continuum). Unfortunately, we are not aware of any careful comparisons of the Eulerian and Lagrangian approaches which clearly delineate their relative merits and limitations. Until such a comparison is made, it seems safest to use the more widely applied Eulerian method. Some of these are listed, together with appropriate references, in Table 2-2.

## 2.4 USING MODELS TO EVALUATE MANAGEMENT ALTERNATIVES

The preceding subsections briefly describe the more popular mathematical approaches to atmospheric contaminant transport. When these descriptions are coded into computer programs they may be used to predict contaminant concentrations at specified times and locations, provided that appropriate input data are available. It is useful at this point to summarize the data requirements of regional dispersion models as well as to consider how practical control measures can be evaluated by manipulating model inputs. This is, of course, a topic which cannot be thoroughly examined in a brief literature review. Nevertheless, some of the more important points can be introduced in just a few paragraphs.

Table 2-3 lists the major inputs required by a general regional atmospheric contaminant dispersion model similar to ACOSP. Next to each input are noted some typical data sources, as well as policy alternatives that may be investigated by manipulating these input values. The most interesting and important input from a policy point-of-view is undoubtedly the source emission rate--the rate of contaminant release resulting, for the most part, from man's activities.

Two kinds of source emission data are needed in practical modeling applications:

- *Historical emission data* which allow the model to be run over a historical time period when contaminant conditions were either monitored or qualitatively observed. If such historical data are available the model may be calibrated (i.e., unknown coefficients may be estimated) and its accuracy may be checked.

TABLE 2-3  
 INPUTS REQUIRED BY A TYPICAL  
 REGIONAL ATMOSPHERIC CONTAMINANT DISPERSION MODEL

TYPE OF INPUT	POSSIBLE DATA SOURCES	POLICY ALTERNATIVES INVESTIGATED BY MANIPULATED INPUT VALUE
Initial contaminant concentrations throughout the region of interest	Recorded values for a particular date (initial time); hypothesized values (e.g., zero contaminant concentration at some pre-development time)	Hypothesized concentration profiles may be imposed on system to investigate air pollution degradation or improvement after initial time. This would be done in conjunction with a particular source emission hypothesis
Contaminant concentrations along the boundaries of the region of interest, generally provided as a function of time	Boundaries are usually chosen to help simplify boundary condition specification (e.g., boundaries may be drawn far enough from emission source to permit boundary concentrations to be set to zero)	Similar role as initial conditions
Average wind speeds throughout the region of interest, generally provided as a function of time	Averages of historical meteorological records; outputs of a predictive atmospheric turbulent flow model; hypothesized values based on a qualitative description of local weather patterns	Hypothesized wind patterns may be imposed to investigate favorable, average, or adverse weather conditions. Actual manipulation as a control measure is probably infeasible.
Inversion layer height	Closely related to meteorological data used to define wind speeds and atmospheric circulations. Based on historic temperature and pressure measurements or hypothesized	Similar role as wind speeds
Local topography	USGS surveys	Questionable relevance to control measures
Dispersion coefficients (conservation of mass) or standard deviations (Gaussian)	The model's most empirical inputs. Based on laboratory and field research studies and/or inferred from historical concentration measurements	Questionable relevance to control measures
Chemical/photo-chemical reaction and decay rates	Similar comments as dispersion coefficients	Questionable relevance to control measures
Source emission rates, expressed as functions of time and location	Either hypothesized or based on historical records, depending on application	See accompanying discussion

- *Hypothesized emission data* which represent some condition to be investigated with the model. Examples include current (observed) emission rates, extrapolated rates based on statistical trends, or rates anticipated if engine exhaust controls of a particular type are imposed.

The second kind of source data, hypothesized data, includes many potential management alternatives. If we confine consideration to transportation-related emissions (see Section 3 for further discussion of this topic related to carbon monoxide) the following examples come to mind (see TSC, 1972):

Possible control measures affecting transportation-related source emissions

1. Engine or exhaust system modifications
2. Restrictions on engine and/or vehicle type
3. Restrictions on fuel type
4. Measures which regulate the entry, flow, or exit of vehicles on traffic arteries in the region of interest
5. Measures which regulate commute schedules or strategies (e.g., car pooling)
6. Measures relating to alternative transportation modes (buses, bike lanes, etc.)

Obviously, more specific examples can be devised for particular applications.

One of the most significant challenges in applying a practical contaminant dispersion model is in translating policy-oriented variables such as speed-limits, commute schedules, and engine exhaust standards into spatially-aggregated emission rates suitable for consumption by a computer model. An interesting and fairly successful example of such a translation is documented in the Vehicle Emissions series of selected papers of the Society of Automotive Engineers (SAE, 1970). Several papers in this series describe analyses which estimated regional mass loading rates in the Los Angeles basin from the following variables:

- Predominant engine types and emission characteristics
- Vehicle types (size, transmission type, etc..)
- Type of engine operation (percent time spent in acceleration, cruising, deceleration, idle, etc.) as well as speed distributions
- Spatial distribution of vehicles expressed as a function of time

When using the SAE approach, the modeler begins by enumerating the individual vehicles likely to be operating in a particular fashion at a particular time and place. He then sums over all possibilities to obtain an aggregated mass-loading rate for each sub-region of his model grid (e.g., for each element). These rates may be hypothesized or based on historical data, depending on the application.

The above summary gives some indication of the factors which must be considered when applying atmospheric contaminant models to practical environmental management problems. Further discussion of model implementation is provided in TSC (1972) as well as in many of the more specific application-oriented studies cited in Tables 2-1 and 2-2.

## 2.5 MODEL PERFORMANCE AND VALIDATION

Although most of the models identified in Tables 2-1 and 2-2 have been applied to some kind of "real-world" problem, very little quantitative information is available on model performance and accuracy. Probably the most basic reason for this is the lack of the historical data needed to conduct a statistically meaningful (or even an intuitively credible) model validation. The temptation in practical model applications is to use all of the available data to help adjust (or calibrate) poorly known model coefficients (e.g., dispersion coefficients or reaction rates). Unfortunately, this leaves no data for tests of the model's predictive capability (i.e., for model validation). Good fits obtained after careful adjustment of the model's coefficients are, by no means, guarantees of good performance in actual predictive applications.

One of the few comprehensive examinations of atmospheric dispersion model performance is the study performed by TSC (1972). This study compares reported model accuracy results for 11 models, including the fairly well-known Los Angeles basin models developed by Systems Applications, Inc. (Roth et. al., 1971) and Systems, Science and Software (Sklarew, 1972). Generally, carbon monoxide predictions were better than those of other pollutants because carbon monoxide is a conservative constituent which is not influenced by poorly known reaction rates. Correlations between measured and simulated carbon monoxide concentrations of 0.70-0.90 are reported in the TSC review, with typical errors cited as being  $\pm 20\%$  of the measured value. It is likely that these figures refer to the model's goodness-of-fit *after* calibration (coefficient adjustment), and thus may not be a realistic measure of the models accuracy in future applications.

It is useful to quote the conclusions section from TSC (1972) which, though it is now several years old, is still quite relevant:

"The results to date are too skimpy to conclusively demonstrate that the conservation of mass approach is superior to the Gaussian methods, although the former has a decisive theoretical advantage...inadequate resolution in the meteorological data is a major factor in modeling inaccuracies, both for the Gaussian and the conservation of mass formulations. It is the universal practice of investigators to point to this source of errors when their models fail--and with good reason...the conventional meteorological network was designed to provide observations on the meso and macro scales (10's to 100's of miles), whereas many pollution problems must be dealt with on the micro scale (miles)."

Fortunately, the availability of fine-scale meteorological data and satisfactory calibration/validation data is increasing. Gradually, it is becoming easier to conduct a convincing model verification and, in the near future, more rigorous and quantitative assessments of model performance should become available.

### 3. COLD REGION CONSIDERATIONS

A review of the somewhat limited literature on air pollution in cold regions does not contradict in any way the basic validity of the conservation of mass modeling approach described in Section 2.3. It seems appropriate, then, to conclude that a conservation of mass model can be applied in the Alaskan environment if the model's inputs take account of the unique characteristics of cold regions.

The classification of model inputs presented in Table 2-3 provides a useful way to organize a discussion of cold region considerations in atmospheric contaminant dispersion. Inspection of this table and the relevant literature suggests that the model inputs most likely to be affected by cold region meteorology are the following:

- Average wind speeds (particularly as they relate to atmospheric stability)
- Inversion layer height
- Dispersion coefficients
- Source emission rates (particularly as they relate to cold weather engine performance)

Chemical and photochemical reaction rates are also affected by the cold temperatures and insolation variations of sub-arctic regions but discussion of such effects is omitted here because they are not relevant to carbon monoxide dispersion (see Section 4). It is useful to group the first two of the above inputs into one category related to cold region micro-meteorology. Each of the resulting three input categories is discussed in one of the following subsections.

### 3.1 COLD REGION MICROMETEOROLOGY

As pointed out in Section 2.5, uncertainties in meteorological data are probably the largest sources of error affecting atmospheric contaminant model predictions. It is useful, therefore, to carefully consider all available information on local meteorology before applying any dispersion model to a practical air pollution problem.

A number of comprehensive reviews of air pollution meteorology have been published, including the annotated bibliography by Munn (1968) and an excellent survey article by Panofsky (1969). More specific studies of particular meteorologic phenomena in cold regions have also been published, particularly on the subject of ice fog. Leaky and Davies (1976) discuss ice fog experiments in Edmonton, Alberta and Huffman and Ohtake (1971) propose an ice fog model for Fairbanks, Alaska, which includes automobile emissions as a source of water vapor. Many other studies discuss particular ice fog sources such as automobiles and cooling towers in considerable detail (see, for example, Nelson, 1973, and Christianson et. al., 1973).

Although there is considerable interest in the behavior of ice fog created by man's activities it is not clear what, if any, effect this fog has on carbon monoxide dispersion. It is likely that the influence of ice fog on water-soluble air-borne contaminants is much more important than it is on carbon monoxide, which is effectively non-reactive in air.

A more important cold region meteorological phenomena is the very steep ground inversion layer which occurs in inland sub-arctic regions during the winter. This phenomena creates an unusually shallow and stable surface layer in which the vertical concentration profile of carbon monoxide and other air pollutants is essentially uniform. An informative discussion of the inversion effect is included in a study of the heat island at Fairbanks, Alaska published by Bowling and Benson (1978). Bowling and Benson found that during the winter, the absence of daily insolation, temperature variations, evapotranspiration and wind, combined with the presence of snow cover, caused the air mass over Fairbanks to be very

stable for long periods of time. The activities of man in such circumstances generate heat which is only slowly dissipated into the surrounding environment. The resulting urban "heat island" is, when skies are clear and winds low, about 10°C warmer than the adjacent atmosphere. The heat island intensity is shown by Bowling and Benson to be strongly correlated with the strength of the inversion.

The Bowling and Benson study not only confirms the remarkable stability of the Fairbanks winter air mass but also suggests that local heat sources will have a significant effect on the temperature of the shallow mixing layer. Under such conditions, advective effects will be very small and the model's results will depend heavily on its dispersion coefficients.

Although atmospheric stability is unusually important at Fairbanks in the winter, the local meteorology is somewhat more typical of northern continental climates during the rest of the year. As diurnal variations increase and the inversion gradient is reduced, advection plays a more significant role. During these warmer periods, the model must be supplied a realistic and consistent velocity field specified at a level of detail roughly comparable to the grid spacing (or element size) adopted for the dispersion model. To develop such a velocity field from limited wind measurements the modeler must take careful account of the modifying effects of local topography. This is a very difficult task which does not appear to have been adequately covered in the literature. We can conclude, therefore, that the atmospheric stability created by the cold winter climate actually helps to make the modeling problem easier than it would be in temperate regions where advective effects can dominate contaminant transport throughout the year.

### 3.2 DISPERSION COEFFICIENTS IN COLD REGIONS

Since the dispersion coefficients of a conservation of mass model are difficult to specify *a priori* in any practical application, they are generally adjusted until the model's predicted concentrations correspond reasonably well to observed concentrations over some historical time period. These adjusted coefficients should not, however, take on any arbitrary value. The adjusted values must lie within a physically plausible range consistent with field and laboratory experiments reported in the literature.

Practical dispersion coefficients depend on the physical and chemical properties of the atmospheric contaminant of interest as well as on the spatial resolution adopted for model computations (see Section 2.3). The dispersion properties of carbon monoxide in cold regions have not been extensively studied, although some information is available. Marrero and Mason (1972) give a good review of diffusion experiments for many binary mixtures of dilute gases, including carbon monoxide in air (i.e., in nitrogen and oxygen). Particular attention is given to temperature effects, which are significant. Although the Marrero and Mason study is useful, it emphasizes molecular diffusion in a quiescent environment, i.e., it does not attempt to incorporate the random dispersive effects associated with atmospheric turbulence. For this reason, the Marrero and Mason coefficients should probably be interpreted as lower bounds in practical applications of conservation of mass dispersion models.

It should be noted that the interpretation of a model's dispersion coefficients depends not only on the spatial resolution of the solution grid but also on the model's dimensionality. In cold regions where inversion heights are low, dispersion in the vertical plane is more constrained than in the horizontal plane. This is an important justification for approximating cold region dispersion with a two-dimensional vertically averaged version of Equation (2-9), as is done in ACOSP (Norton and Carlson, 1976). The velocity-related turbulent effects in such a vertically-averaged model can be accounted for, in an approximate way at least, by allowing the dispersion coefficient to be a function of both velocity

and molecular diffusivity. An example given by Reddell and Sunada (1970) is:

$$K_{ix} = \alpha_{li} \frac{V_x^2}{|V|} + \alpha_{ti} \frac{V_y^2}{|V|} + d_i$$

$$K_{iy} = \alpha_{ti} \frac{V_x^2}{|V|} + \alpha_{li} \frac{V_y^2}{|V|} + d_i$$

where  $\alpha_{li}, \alpha_{ti}$  = turbulent dispersive coefficients longitudinal and transverse to the wind velocity vector

$V_x, V_y$  = components of the wind velocity vector in the x and y directions

$|V|$  = wind velocity magnitude

$d_i$  = molecular diffusivity for constituent i (as given by Marrero and Mason, 1972).

Similar semi-empirical relationships have been suggested by other investigators, although there are very few examples of field verification in cold regions. Additional field research on low-temperature dispersion would probably provide some very helpful information to both model developers and users.

### 3.3 COLD REGION EFFECTS ON SOURCE EMISSION RATES

As pointed out in Section 4, the major sources for carbon monoxide in urban areas are vehicular emissions. For this reason, the influence of cold weather conditions on model carbon monoxide mass loading rates will be felt primarily through the effects of temperature on engine performance. A secondary effect, which is somewhat harder to quantify, is the role weather plays in driving habits and traffic patterns.

A number of useful studies of the effects of cold weather on vehicular emissions in general and on carbon monoxide in particular have been published. Edwards and Teague (1970) give a general background on emission

generation processes for spark ignition engines in a paper presented at the Society of Automotive Engineers (SAE) 1970 mid-year meeting. Generally speaking, SAE publications, such as SAE (1970), are good sources of information on engine performance.

A more specific source on the effects of cold weather is Polak (1974). This paper summarizes the results of tests conducted in Canada on five 1972 and 1973 model year vehicles. The tests include various types of cold starts over a range of low temperatures. Results indicated that both hydrocarbon and carbon monoxide emissions increased over 100% when temperatures were dropped from 60°F to 0°F. Engine coolant heaters substantially reduced this adverse effect, while prolonged idling after a cold start tended to increase it.

The references cited above provide guidelines as to how temperate weather emission data should be modified for cold climates. Other citations covering all aspects of vehicle emissions are given in the annual NTIS bibliographies on Automobile Air Pollution (for example, Lehman, 1976).

#### 4. CARBON MONOXIDE CONSIDERATIONS

Carbon monoxide is a distinctive atmospheric contaminant in several ways. First, since it is invisible, tasteless, and odorless it does not have the perceptual impact associated with photochemical smog. Second, its effects on human health are relatively well understood, as compared to hydrocarbons and some other atmospheric pollutants. Third, it is essentially a non-reactive, conservative constituent.

The health-related effects of carbon monoxide are discussed in a number of important reviews and medical studies. A good example is the Nashville Air Pollution and Health Study (Kenline and Conlee, 1968), which relies on a substantial base of aerometric and public health data. Further relevant information is presented in Ipsen et. al. (1968) which concentrates on the health effects of episodic increases in contaminant levels in urban areas. A more quantitative approach to predicting the health effects of carbon monoxide is discussed in Ott and Mage (1978). This paper uses a computerized model of carbon monoxide transport in hemoglobin to assess the medical significance of ground-level carbon monoxide concentrations.

Since carbon monoxide is a conservative atmospheric constituent it is readily modeled with the conservation of mass approach described in Section 2.3 (the reaction rate  $R_j$  appearing in Equations (2-7) and (2-9) is zero in this case). The model inputs most likely to be dependent on the particular physical and chemical properties of carbon monoxide are the dispersion coefficient and the source emission rate. Since carbon monoxide dispersion is discussed in Section 3.2, only source emissions will be considered in this subsection.

Mathis and Grose (1973) present in their review of air pollution modeling the following national summary of carbon monoxide emissions:

Carbon Monoxide Emissions in the U.S. (1969)  
(millions of tons/yr)

<u>Source</u>	<u>Emissions</u>
Transportation	111.5
Fuel combustion in stationary sources	1.8
Industrial processes	12.0
Solid waste disposal	7.9
Miscellaneous	<u>18.2</u>
	151.4

This summary indicates that nearly 75% of national carbon monoxide emissions were related to transportation in 1969. It is conceivable that the percentage in relatively unindustrialized Alaskan urban areas is even higher.

As mentioned in Section 3.3, Edwards and Teague (1970) and SAE (1970) are both good sources of information on vehicular carbon monoxide emissions. Other useful references include Griffiths and Griffiths (1974), and Snyder et. al. (1972) which discuss the effectiveness of various control measures, including catalytic converters. Emissions resulting from aircraft activities are discussed in the annual NTIS reviews on aircraft air pollution (see, for example, Cavagnaro, 1976) and in various model application reports such as Tigue and Carpenter (1975).

Preprocessing routines for developing carbon monoxide nodal mass loading rates from vehicle emission and traffic distribution data are described in some of the documentation reports listed in Table 2-2, particularly paper No. II in the series by Roth et. al. (1974). Roth et. al. gives empirical expressions for converting individual vehicle emission data into the grid cell source terms for a finite difference model application in Los Angeles. Most of the basic concepts of their approach should be applicable in Alaska, although the values of specific coefficients in the empirical expressions will probably have to be modified. The Roth et. al. approach can also be readily incorporated into finite element solution routines such as those used in ACOSP.

More general references on carbon monoxide emissions from a variety of sources, including power plants, lumbering operations, and solid waste disposal sites are cited in the various NTIS bibliographies listed at the end of this report.

## 5. SUMMARY AND CONCLUSIONS

### SUMMARY OF THE LITERATURE REVIEW

The major points revealed by our review of the literature on atmospheric modeling, cold regions, and carbon monoxide can be summarized as follows:

#### Mathematical Modeling

- Most mathematical models of atmospheric contaminant movement are based on either the Gaussian dispersion approach or the conservation of mass approach. Examples of these approaches are listed in Tables 2-1 and 2-2, respectively.
- The principal advantages of the Gaussian approach are its computational simplicity and intuitive appeal. Its principal disadvantages are the restrictions imposed by assumptions such as continuous and uniform emission sources, constant wind speed, total reflection at the earth's boundaries, and non-reactivity of chemical constituents. In general, Gaussian models are best suited for relatively simple dispersion problems where qualitative impact assessments are the primary goal.
- The principal advantages of the conservation-of-mass approach are its generality, flexibility and strong theoretical foundation. Its principal disadvantage is its computational complexity. Eulerian (fixed frame) conservation-of-mass models rely on numerical integration routines while Lagrangian (moving frame) conservation-of-mass models need complex bookkeeping algorithms to keep track of many discrete moving particles.

In either case, computer programming and computer run time requirements are greater than with simpler Gaussian models.

- The input requirements of Gaussian and conservation-of-mass models are similar. Both require information on source emission rates, average wind velocities, and random dispersion characteristics. When reactive constituents are to be modeled, chemical/photo-chemical reaction and decay rates must also be specified. The poorest known of these inputs is generally the wind velocity field. The inadequacy of wind data is, in fact, nearly always the major factor limiting model performance.
- Overall, the flexibility, accuracy and usefulness of the conservation-of-mass approach appears to outweigh its computational disadvantages. Gaussian models may give results nearly as good as conservation-of-mass models in some specialized applications, but they cannot compete in regional situations with many moving sources and time-varying meteorological conditions.
- Although rigorous quantitative comparisons of model performance are not available, it appears that Eulerian conservation-of-mass models are more reliable than Lagrangian and hybrid types. Finite element Eulerian models are generally more adaptable to irregular geometries than finite difference Eulerian models. The regional orientation of the finite element method (many inputs are specified by element rather than by node) is also convenient in practical applications where data may be areally averaged. Consequently, Eulerian finite element models seem to be the best choice for regional atmospheric contaminant studies, particularly when source and meteorological conditions vary significantly over time and space.

## Cold Regions

- Most conservation-of-mass models are applicable to cold regions such as Alaska if they take proper account of the effects of cold weather on atmospheric inversions, dispersion coefficients, and source emission rates. Good information on these effects is available in the literature.
- The atmospheric stability created by a cold winter climate actually helps to make the modeling problem easier since it reduces the role of advective effects and, therefore, the dependence of the model on wind data. Low inversion heights also help simplify modeling by making two-dimensional (vertically averaged) approximations more valid.

## Carbon Monoxide

- Carbon monoxide is one of the best understood and most easily modeled atmospheric contaminants. Since most carbon monoxide emissions are from motor vehicles, vehicle emission tests and transportation data provide most of the information needed to define carbon monoxide model source rates. A number of algorithms for developing source rates from readily available vehicle data have been reported in the literature.

These conclusions suggest that the technology and data are available for applying predictive models to practical problems of carbon monoxide dispersion in Alaska.

## CONCLUSIONS RELATING TO FURTHER DEVELOPMENT AND APPLICATION OF ACOSP

In this subsection, we briefly consider how ACOSP fits into the overall state-of-the-art of atmospheric modeling as well as identify technological

innovations which may make ACOSP especially versatile and easy to use. ACOSP (Atmospheric Carbon Monoxide Simulation Program) is a two-dimensional Eulerian conservation-of-mass model designed to predict vertically-averaged atmospheric concentrations of conservative constituents such as carbon monoxide (Norton and Carlson, 1976). The model could be readily modified to include other reactive constituents if a reactive source/sink term were included. At this time, however, it seems appropriate to focus attention on carbon monoxide, which appears to be the most important atmospheric contaminant in the urban areas of Alaska.

Based on a survey of the available literature, ACOSP appears to be the only atmospheric dispersion model which uses a finite element solution technique. This gives ACOSP a unique ability to deal with irregularly shaped airsheds. It also allows ACOSP to use particularly efficient grid schemes in environments where atmospheric circulations follow established patterns related, for example, to local topography.

The two-dimensional nature of ACOSP is a limitation justified primarily by the low inversion height found in Alaskan cities such as Fairbanks, where vertical variations in carbon monoxide concentration are small compared to horizontal variations (below the inversion height). A number of the finite difference models listed in Table 2-2 are three-dimensional and can deal with the vertical effects found in less strongly stratified systems.

Since the ACOSP model seems to be suitable for the Alaskan environment and representative of the state-of-the-art in atmospheric dispersion modeling, it is appropriate to consider how ACOSP's inputs should be specified or estimated. Here we can benefit greatly from other model applications as well as from the literature on automotive emissions and cold region meteorology. One of the best ways to obtain realistic inputs for a dispersion model is to use a set of preprocessor routines similar to that developed by Roth et. al. (1974). Such routines translate readily available demographic, traffic, and vehicle emission data into a model compatible (node-oriented) form. In the ACOSP case, the preprocessor

routines should be structured to accept emission data available from standard sources such as the SAE technical paper series (e.g., SAE, 1970) and should incorporate temperature-dependent effects relevant to cold regions.

Another important area of emphasis is the definition of atmospheric circulation patterns and dispersion coefficients. Further investigation of topographical effects on atmospheric circulation and of the conditions giving rise to steep inversion gradients would be very useful. Empirical expressions relating the model's dispersion coefficients to variables such as wind speed and inversion height should be considered, since such expressions could make the model calibration process easier and more reliable.

Serious consideration should also be given to methods for making ACOSP easier to use and interpret. Special emphasis should be given to the evaluation of possible control measures through manipulation of the model's inputs (or, preferably, the inputs to the preprocessor routines mentioned above). The model applications listed in Table 2-2 all offer ideas for the presentation of results and evaluation of control measures which are potentially relevant to the Alaskan environment. Further review of these and other model applications would be useful.

As a final note, it is worth repeating the often-heard warning that a model's predictions are no better than its input data. *mod. conditions* *and* *inputs* *and* *outputs* Uncertainties and errors in wind velocities, initial conditions, dispersion coefficients, and source emission rates propagate directly through to the model's outputs. The more important an input is, the more effect its uncertainties will have. For this reason it is particularly important that ACOSP applications be strongly supported by a good data collection program which relies both on field studies in Alaska and on laboratory and field results from the literature. This is probably the single most important factor in making ACOSP a reliable tool for planning and impact evaluation.

## REFERENCES

- Ahlistrom, S.W. et al. 1977. Multicomponent Mass Transport Model: Theory and Numerical Implementation (Discrete - Parcel - Random - Walk Version). Battelle Northwest Laboratories. Richland, Washington. BNWL-2127.
- Beals, G.A. May, 1971. Guide to Local Diffusion of Air Pollutants. Air Weather Service, U.S.A.F. Tec. Rept. 214.
- Bird, R.B., W.E. Stewart and E.N. Lightfoot. 1960. Transport Phenomena. John Wiley and Sons. New York.
- Bowling, S.A. and C.S. Benson. June, 1978. Study of the Subarctic Heat Island at Fairbanks, Alaska. Alaska University College, Geophysical Institute, Environmental Sciences Research Laboratory. Research Triangle Park, N.C. EPA Grant EPA-80299.
- Carlson, R.F. and J.D. Fox. 1976. An Atmospheric Carbon Monoxide Transport Model for Fairbanks, Alaska. Institute of Water Resources, University of Alaska, Fairbanks. Report No. IWR-75. 47 pp.
- Cavagnaro, Diane M. 1976. National Technical Information Service (NTIS). Computerized Air Pollution Bibliographies.
- Christianson, A.G., F.H. Rainwater, M.A. Shirazi and B.A. Tichenor. October, 1973. Wet Cooling Tower. In Reviewing Environmental Impact Statements - Power Plant Cooling Systems, Engineering Aspects. Environmental Protection Agency. Corvallis, Oregon. Pacific Northwest Environmental Research Laboratory Report EPA-660/2-73-016, p. 21 - 34.
- Cramer, H.E. 1957. A Practical Method for Estimating the Dispersion of Atmospheric Contaminants. Proc. First National Conference on Applied Meteorology. American Meteorological Society.
- Crohe, E.J., et al. 1968. Chicago Air Pollution System Model. Argonne National Laboratory, Progress Reports ANL/ES-CC-001, 002 & 003.
- Donaldson, C. du P. and G.R. Hilst. 1971. Computing Dispersal of Atmospheric Pollutants Near Airports. NASA CR-111962, Aeronautical Research Association of Princeton, New Jersey.
- Edwards, J.J. and D.M. Teague. 1970. Unraveling the Chemical Phenomena Occurring in Spark Ignition Engines. Presented at the Society of Automotive Engineers, Mid-Year Meeting, Detroit, Michigan.
- Gifford, F.A. 1961. Uses of Routine Meteorological Observations for Estimating Atmosphere Dispersion. Nuclear Safety (2) 4.
- Griffiths, J.F. and M.J. Griffiths. 1974. Bibliography of the Urban Modification of the Atmospheric and Hydrologic Environment. NOAA TM EDS 21, Rept. NOAA-74032231, p. 1 - 69, 92.
- Huffman, P.J. and T. Ohtake. January, 1971. Formation and Growth of Ice Fog Particles at Fairbanks, Alaska. J. Geophysics Research, 76(3): 657-665.
- Institute of Water Resources (I.W.R.) 1979. Improvement of the Fairbanks Atmospheric Carbon Monoxide Transport Model - A Program for Calibration, Verification and Implementation. Institute of Water Resources. University of Alaska, Fairbanks. Proposal IWR 80-17.

- Ipsen, J., M. Deane and F.E. Ingenito. 1968. Episodic Morbidity and Mortality in Relation to Air Pollution (Part I). Relationships of Acute Respiratory Disease to Atmospheric Pollution and Meteorological Conditions (Part II). Preprint, American Medical Assoc., 35 p.
- Kenline, P.A. and C.J. Conlee. January, 1968. The Nashville Air Pollution and Health Study, A Summary. Public Health Dept. (U.S.) 82, (1), 17-29.
- Knox, Joseph B. 1973. Numerical Modeling of the Transport, Diffusion and Deposition of Pollutants for Regions and Extended Scales. Lawrence Livermore Laboratory Reprint UCRL-74666.
- Lehmann, E.J. 1976. National Technical Information Service (NTIS). Computerized Urban Air Pollution Bibliographies.
- Lehmann, E.J. July, 1975. Urban Air Pollution (A Bibliography with Abstracts). NTIS.
- Leaky, Douglas M. and J. E. Davis. 1976. A Study of Low Temperature Fog in Edmonton, Alberta. Presented at the Air Pollution Control Association Pacific Northwest International Section Meeting, September 15 - 17.
- Mathis, J.J. and W.L. Grose. 1973. A Review of Methods for Predicting Air Pollution Dispersion. NASA Langley Research Center Report SP-322.
- Marrero, T.R. and E.A. Mason. 1972. Gaseous Diffusion Coefficients. J. Physical Chemistry Reference Data, 1 (1):3-118.
- Munn, R.E. July, 1968. Annotated Bibliography for Air Pollution Meteorology. J. Air Pollution Control Assoc., 18 (7):449-453.
- NATO Committee on the Challenges of Modern Society. October, 1977. Air Pollution: Assessment Methodology and Modeling. Bibliography of Grey Literature on Air Quality Modeling (GAUSSian Plume Models. Report No. NATO/CCMS-70.
- NATO Committee on the Challenges of Modern Society. October, 1978. Bibliography on Grey Literature on Air Quality Modeling, Part II. New Modeling Techniques Report No. NATO/CCMS-88.
- Nelson, W.G. 1973. A Numerical Analysis of Ice Fog Produced by Automobiles. Ph.D. Thesis, Oregon State University, Corvallis, Dept. of Mechanical Engineering.
- Norton, W.R., and R.F. Carlson. 1976. User's Guide for Atmospheric Carbon Monoxide Transport Model. Institute of Water Resources, University of Alaska, Fairbanks. Report No. IWR-76. 157 pp.
- Ott, W.R. and D.T. Mage. September, 1978. Interpreting Urban Carbon Monoxide Concentrations by Means of a Computerized Blood CoHB Model. J. Air Pollution Control Association, Vol. 28, No. 9.

- Panofsky, H.A. 1969. Air Pollution Meteorology. American Scientist. Vol. 57, No. 2, pp. 269-285.
- Pasquill, F. 1961. The Estimation of the Dispersion of Windborne Material. Meteorological Magazine 90, 1063.
- Pinder, G.F. and H.H. Cooper, Jr. 1970. A Numerical Technique for Calculating the Transient Position of the Saltwater Front. Water Resources Research. 6(3).
- Polak, J.C. June, 1974. Effect of Cold Weather on Motor Vehicle Emissions. Air Pollution Control Directorate. Ottawa, Ontario. Emission Testing Laboratory Report, Environmental Protection Service 4-Air Pollution - 74-1, 44 pp.
- Reddell, D.L. and D.K. Sunada. 1970. Numerical Simulation of Dispersion in Ground Water Aquifers. Department of Civil Engineering Report. Colorado State University. Fort Collins, Colorado.
- Resources for the Future (RFF). 1979. Analysis for Regional Residents - Environmental Quality Management: Analyzing Natural Systems. Chapter 9 (Analyzing Atmospheric Systems). Available from U.S.E.P.A. Environmental Research Laboratory, Athens, Georgia.
- Reynolds, S.D. et al. 1974. Mathematical Modeling of Photochemical Air Pollution (Parts II and III). Atmospheric Environment. Vol. 8, pp. 97 - 130 and 563 - 596.
- Roth, Philip M. et al. 1971. Development of a Simulation Model for Estimating Ground Level Concentration of Photochemical Pollutants, Rpt. 71SAI-21. Systems Applications, Inc. Beverly Hills, California.
- Sklarew, Ralph C. 1970. A New Approach: The Grid Model of Urban Air Pollution, APCA Paper No. 70 - 79. Systems, Science and Software. LaJolla, California.
- Smith, M.E. 1961. The Concentration and Residence Times of Pollutants in the Atmosphere, Chemical Reactions in the Lower and Upper Atmosphere. Interscience. New York, N.Y.
- Snyder, P.W., W.A. Stover and H.G. Lassen. May, 1972. Status Report on HC/CO Oxidation Catalysts for Exhaust Emission Control, presented at the Society of Automotive Engineers, National Automobile Engineering Meeting, Detroit, Michigan, May 22 - 26, 1972, and the American Petroleum Institute, Refining Division Meeting, New York, May 8 - 11, 1972.
- Society of Automotive Engineers. 1970. Technical Papers Series. Vehicle Emissions - - Selected S.A.E. Papers from 1967 - 1970. New York, New York.
- Sutton, O.G. 1932. A Theory of Eddy Diffusion in the Atmosphere. Proc. Roy. Soc. A.
- Taylor, G.I. 1922. Diffusion by Continuous Movement. Proc. London Mathematical Society 20, Series 2.

Tigue, J.E. and L.K. Carpenter. December, 1975. Air Quality Impact Analysis of a Proposed North/South Runway at Anchorage International Airport. F.A.A., Washington, D.C. Systems Research and Development Service. Final Report No. FAA-RD-75-179.

Transportation Systems Center (TSC). 1972. Computer Modeling of Transportation Generated Air Pollution: A State-of-the-Art Survey. Available from NTIS (PB-213 013). 89 pp.

Turner, D.B. July, 1971. Workbook of Atmospheric Dispersion Estimates. Environmental Health Series, Air Pollution: EPA.