

APPENDIX A

A-1 to A-5

Appendix A. Design of Guide (D1, D2, D3, and E) Signs

Determine sign, letter, number, space, symbol, border, and margin dimensions and arrangement as follows:

1) Size letters, numbers, symbols, and arrows.

- a) Size letters, numbers, and intervening spaces in accordance with Appendix C.
 - i) Unless otherwise noted on sign drawings, use the Clearview 5-W typeface for all letters and numbers, unless it is critical to minimize sign width, in which case use Clearview 5-W-R.
 - ii) Do not use periods for the standard abbreviations listed in section 11 of this appendix.
 - iii) When ordinal number street names are given in symbol form (e.g. 100th), use lowercase lettering for the alpha ending.
- b) Size arrows in accordance with Appendix B.
- c) Size symbols as shown on sign drawings. Symbols may be cut from the Adobe Acrobat sign layouts available on the Internet and scaled as required for each sign.

2) Size Fractions

- a) Treat fractions as a unit and not as separate characters. This unit is called the "fraction rectangle," which consists of the numerals and diagonal.
- b) The width of the fraction rectangle is 2.5 times the fraction numeral height, except when the upper numeral is "1", in which case its width is 2 times the numeral height.
- c) The height of the fraction rectangle is 1.5 times the uppercase letter height.
- d) Set the bottom of the fraction rectangle 0.25 times the uppercase letter height below the baseline (the line on which the non-fraction numbers or text rest).
- e) The diagonal length is 1.7 times the fraction numeral height; its width is equal to the stroke width of the numeral and is mounted at an angle of 60° from the horizontal.

Appendix A. Guide (D1, D2, D3, and E) Sign Layout

3) Determine spacing between words, arrows, fractions, and symbols.

- a) Set the space between words, a word and an arrow, and a number and an arrow equal to the upper-case letter height. If the heights of neighboring words or numbers differ, use the average height.
- b) Set the space between a word and number at 1.5 times the upper-case letter height. If the heights of neighboring words and numbers differ, use the average height.
- c) Set the space between a fraction rectangle and a preceding or following letter at the fraction numeral height.
- d) In cases where it is necessary to reduce sign size, you may reduce inter-character spacing, but not to less than $2/3$ of these values.

4) Determine sign height and width.

a) Height

- i) Sign height and vertical spaces are usually specified on sign drawings. If not, size as follows:
 - (1) Set vertical spaces between lines equal to the height of upper case letters in the upper line plus the height of upper case letters in the lower line divided by two.
 - (2) Set vertical spaces between a line and the edge of sign equal to the height of upper case letters in the line.
 - (3) Add the spaces and letter heights for all lines on the sign.
 - (4) Round off to the nearest (usually) 6-inch increment. Use judgment when rounding down to ensure adequate clearances and separations (don't reduce to less than $2/3$ of values given).
 - (5) Distribute the change to height that results from rounding proportionally to all vertical spaces.

b) Width

- i) Determine the width of the widest legend on the sign in accordance with 1), 2), and 3) above.
- ii) Add spaces between the sign message and the left and right edges of the sign equal to the upper-case letter height.
- iii) Round to the nearest 6-inch increment. This is the final width.

Appendix A. Design of Guide (D1, D2, D3, and E) Signs

5) Arrange Lines in Order on Multi-Line Signs

- a) On signs with arrows, arrange destinations from top to bottom by arrow type in the order shown below, locating the arrow near the sign edge indicated.

| Arrow type | Priority | Location |
|------------------------|----------|----------|
| Vertical Arrow | 1 | Left |
| Advance Left Arrow | 2 | Left |
| Diagonal Left Arrow | 3 | Left |
| Horizontal Left Arrow | 4 | Left |
| Diagonal Right Arrow | 5 | Right |
| Horizontal Right Arrow | 6 | Right |

- b) On mileage signs without arrows, arrange destinations from top to bottom by distance, the nearest at the top, the farthest at the bottom.
- c) On signs with both mileage and arrows, arrange in arrow-type priority.
- d) When a single arrow indicates the direction to two destinations, the nearest destination should be listed on top.

6) Group and Separate Destinations in Different Directions On Multi-line Signs with Arrows

- a) Add a white horizontal line equal in width to the sign's border between destinations in different directions. This is necessary to avoid drivers associating an arrow on one line with a destination on another (a surprisingly common occurrence). Provide the additional height necessary to accommodate the line.

When two destinations lie in the same direction, use a single two-line arrow vertically centered between the lines.

7) Locate Messages Horizontally

- a) On the widest line on a sign, determine the final offset between the message and the left and right sign edges (the “edge offset”) by subtracting the legend width from the final sign width and dividing by two.
- b) On shorter lines, arrange content as follows:
- Lines that consist of a complete name only: center the message and let the edge offsets vary.
 - Lines that consist of a complete name and an arrow:

Appendix A. Guide (D1, D2, D3, and E) Sign Layout

- (1) Set the arrow at the edge offset of the widest line from the near edge.
 - (2) Offset the name from the arrow by the amount specified under 3) above.
 - (3) To present a neat appearance, make minor adjustments to line up the edge of text nearest the arrow with the edges of text of lines above and below that have arrows on the same side of the sign. This does not apply to lines with two-line arrows.
- iii) Lines that consist of part of a name (because the name is too long for one line): set the left edge offset equal to the one on the widest line and let the right edge offset vary.
- iv) Lines that consist of a word and a number:
- (1) set the left and right edge offsets equal to those of the widest line
 - (2) let the space between the word and number vary.
- v) Lines that consist of a word, number, and an arrow:
- (1) set the left and right edge offsets equal to those of the widest line.
 - (2) let the space between the word and number vary.
 - (3) left-justify words to the right of the arrows whenever possible.
- vi) Lines with two destinations per arrow. When two destinations lie in the same direction, use a single two-line arrow, and arrange lines of legend as follows:
- (1) When one of the lines, with the arrow, is the widest line on the sign, arrange it in accordance with the instructions for the widest lines in 7)a).
 - (2) Arrange shorter lines as follows:
 - (a) Lines that consist of a word and a number:
 - (i) On the arrow side of the sign, offset the word or number from the arrow in accordance with 3).
 - (ii) On the other side of the sign, set the word or number at an edge offset equal to that on the widest line.
 - (iii) Let the space between the word and number vary.
 - (b) Lines that consist of a word only:
 - (i) On the arrow side of the sign, offset the word or number from the arrow in accordance with 3).
 - (ii) Let the other edge offset vary.

Appendix A. Design of Guide (D1, D2, D3, and E) Signs

- c) Locate symbols and adjacent text as shown on sign drawings.

8) Determine Corner Radius

- a) Round the corners of all destination signs. If corner radius is not specified on sign drawings, use a radius approximating 1/16 of sign height or width; whichever is less, to a maximum of four inches.

9) Determine Border Width

- a) Place borders on all destination signs. Locate so the edge of the border coincides with the edge of sign. If border width is not specified on sign drawings, use the following width:

| <u>Largest Letter Size Used</u> | <u>Border Width</u> |
|--|----------------------------|
| 6" Caps | 0.75" |
| 6" Uppercase or 8" Caps | $0.50" + 0.25(*N-1)$ |
| 8" Uppercase or 10" Caps | $0.75" + 0.25(*N-1)$ |
| 10.7" Uppercase or 12" Caps | $1.00" + 0.25(*N-1)$ |
| 13.3" Uppercase or 15" Caps | $1.25" + 0.25(*N-1)$ |
| 16" Uppercase or 18" Caps | 2" |
| 20" Uppercase | 3" |

**N = Number of lines of legend*

10) Miscellaneous

- a) If no angle is specified, set the centerline of diagonal arrows on a 45-degree angle.

11) Standard Abbreviations.

The abbreviations listed in Table 1A-1 and 1A-2 of the 2003 Manual on Uniform Traffic Control Devices may be used to minimize sign length.

APPENDIX B

B-1 to B-5

Appendix B. Arrows

Standard Arrow Details

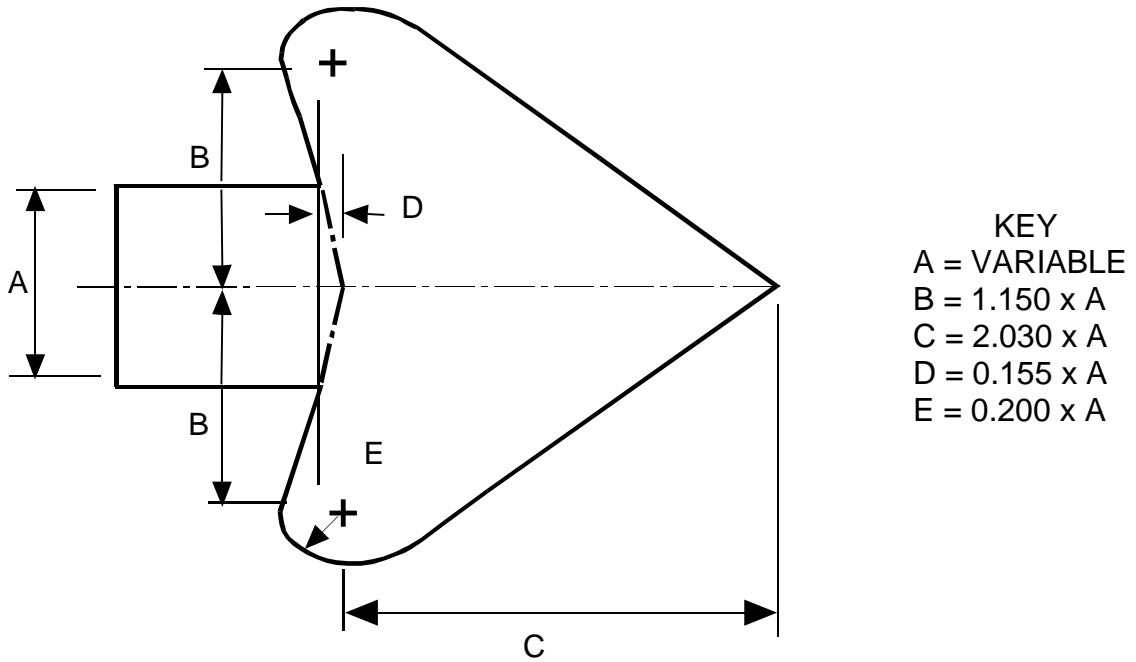

Dimensions (inches)

| A | B | C | D | E | A | B | C | D | E |
|------|------|------|------|------|------|------|-------|------|------|
| 0.75 | 0.86 | 1.52 | 0.12 | 0.15 | 4.00 | 4.60 | 8.12 | 0.62 | 0.80 |
| 1.00 | 1.15 | 2.03 | 0.16 | 0.20 | 4.06 | 4.67 | 8.25 | 0.63 | 0.81 |
| 1.25 | 1.44 | 2.54 | 0.19 | 0.25 | 4.25 | 4.89 | 8.63 | 0.66 | 0.85 |
| 1.50 | 1.73 | 3.05 | 0.23 | 0.30 | 4.38 | 5.03 | 8.88 | 0.68 | 0.88 |
| 1.63 | 1.87 | 3.30 | 0.25 | 0.33 | 4.50 | 5.18 | 9.14 | 0.70 | 0.90 |
| 1.75 | 2.01 | 3.55 | 0.27 | 0.35 | 4.75 | 5.46 | 9.64 | 0.74 | 0.95 |
| 2.00 | 2.30 | 4.06 | 0.31 | 0.40 | 4.88 | 5.61 | 9.90 | 0.76 | 0.98 |
| 2.25 | 2.59 | 4.57 | 0.35 | 0.45 | 5.00 | 5.75 | 10.15 | 0.78 | 1.00 |
| 2.50 | 2.88 | 5.08 | 0.39 | 0.50 | 5.25 | 6.04 | 10.66 | 0.81 | 1.05 |
| 2.63 | 3.02 | 5.33 | 0.41 | 0.53 | 5.50 | 6.33 | 11.17 | 0.85 | 1.10 |
| 2.75 | 3.16 | 5.58 | 0.43 | 0.55 | 5.75 | 6.61 | 11.67 | 0.89 | 1.15 |
| 3.00 | 3.45 | 6.09 | 0.47 | 0.60 | 6.00 | 6.90 | 12.18 | 0.93 | 1.20 |
| 3.13 | 3.59 | 6.34 | 0.48 | 0.63 | 6.50 | 7.48 | 13.20 | 1.01 | 1.30 |
| 3.25 | 3.74 | 6.60 | 0.50 | 0.65 | 7.00 | 8.05 | 14.21 | 1.09 | 1.40 |
| 3.31 | 3.81 | 6.73 | 0.51 | 0.66 | 7.50 | 8.63 | 15.23 | 1.16 | 1.50 |
| 3.50 | 4.03 | 7.11 | 0.54 | 0.70 | 8.00 | 9.20 | 16.24 | 1.24 | 1.60 |
| 3.75 | 4.31 | 7.61 | 0.58 | 0.75 | | | | | |

Guide Sign Up Arrow

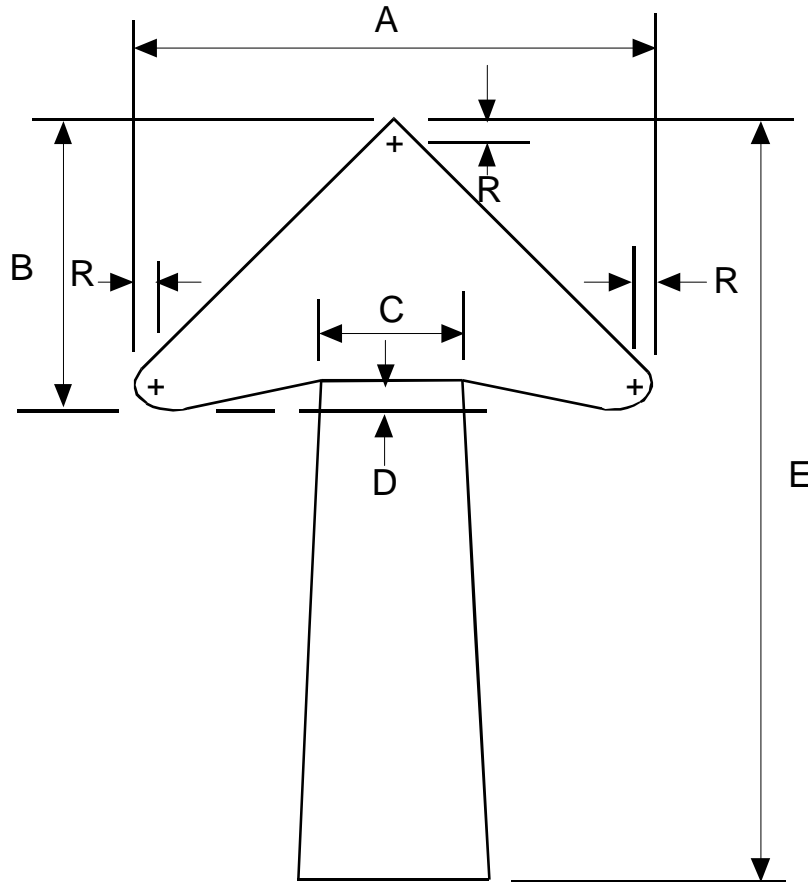

| DIMENSIONS (INCHES) | | | | | | | | |
|---------------------|---------------------------|---------------|----------------------------|-------|-------|-------|----|-----|
| ARROW NO. | LETTER SIZE(U.C.) | LINES OF COPY | ARROW DIMENSIONS IN INCHES | | | | | |
| | | | A | B | C | D | *E | R |
| 1 | 8" U.C. OR 8" CAPS. | 1 | 11 | 8 1/2 | 2 3/4 | 7/8 | 13 | 1/2 |
| 2 | 8" CAPS. | 2 | 11 | 8 1/2 | 2 3/4 | 7/8 | 18 | 1/2 |
| 3 | 10.67" - 13.33" U.C. | 1 | 18 1/4 | 14 | 4 1/2 | 1 1/2 | 20 | 3/4 |
| 4 | OR 10" CAPS. | 2 | 18 1/4 | 14 | 4 1/2 | 1 1/2 | 30 | 3/4 |
| 5 | 16" U.C. OR 12" CAPS. | 1 | 22 1/4 | 17 | 5 3/8 | 1 3/4 | 25 | 1 |
| 6 | 12" CAPS. | 2 | 22 1/4 | 17 | 5 3/8 | 1 3/4 | 35 | 1 |

TAPER OF 1/2" PER FOOT SHALL BE HELD CONSTANT FOR LONGER OR SHORTER SHAFT LENGTHS.

Appendix B. Arrows

Guide Sign Down Arrow

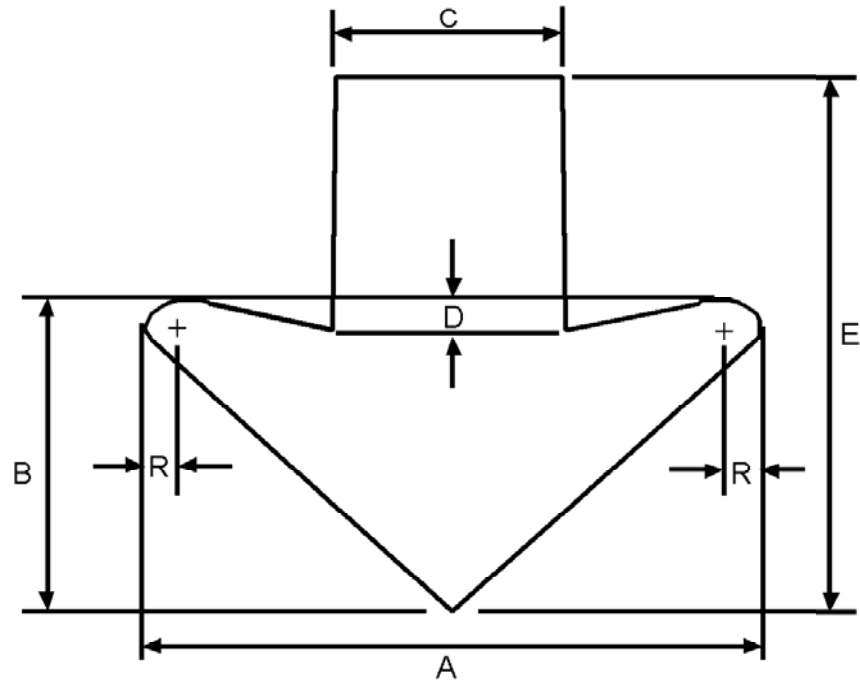

| DIMENSION IN INCHES | | | | | |
|---------------------|--------|-------|-------|--------|-----|
| A | B | C | D | E | R |
| 22 1/2 | 11 1/4 | 5 | 2 1/4 | 16 1/2 | 3/4 |
| 32 | 16 | 6 1/2 | 3 | 22 | 1 |

Guide Sign Diagonal Tapered Stem Arrow

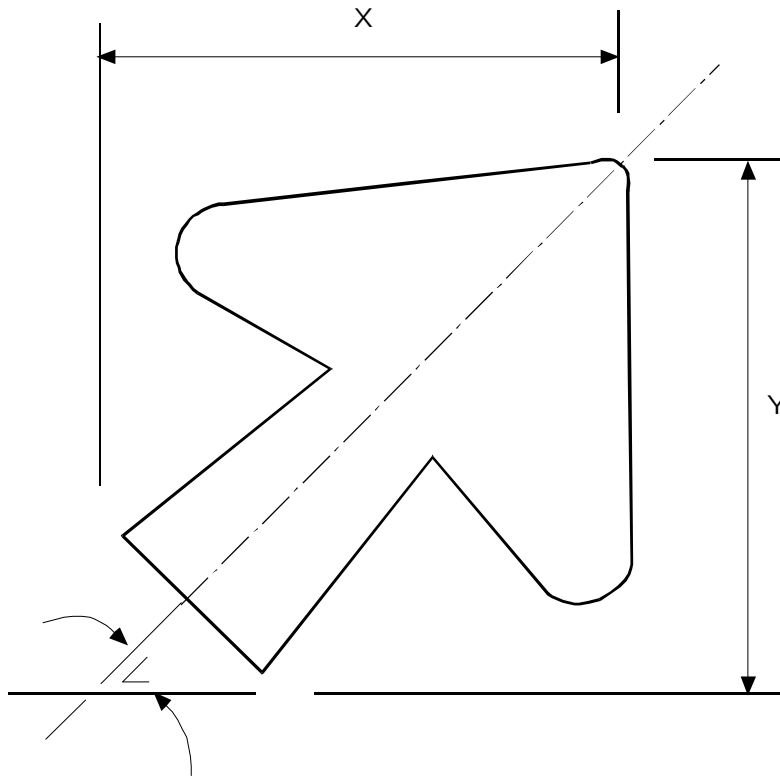

| Arrow No. | Dimensions in Inches | | | | | |
|-----------|----------------------|--------|--------|--------|--------|--------|
| | Angle of Arrow (∠) | | | | | |
| | 30° | | 45° | | 60° | |
| | X | Y | X | Y | X | Y |
| 1 | 12 1/4 | 9 7/8 | 10 7/8 | 10 7/8 | 9 7/8 | 12 1/4 |
| 2 | 16 7/8 | 12 1/4 | 14 3/4 | 14 3/4 | 12 1/4 | 16 7/8 |
| 3 | 18 3/4 | 16 | 16 3/8 | 16 3/8 | 16 | 18 3/4 |
| 4 | 27 3/4 | 20 1/4 | 23 5/8 | 23 5/8 | 20 1/4 | 27 3/4 |
| 5 | 23 1/2 | 17 3/4 | 20 1/4 | 20 1/4 | 17 3/4 | 23 1/2 |
| 6 | 32 1/4 | 22 5/8 | 27 1/2 | 27 1/2 | 22 5/8 | 32 1/4 |

Appendix B. Arrows

Guide Sign Advance Turn Arrow

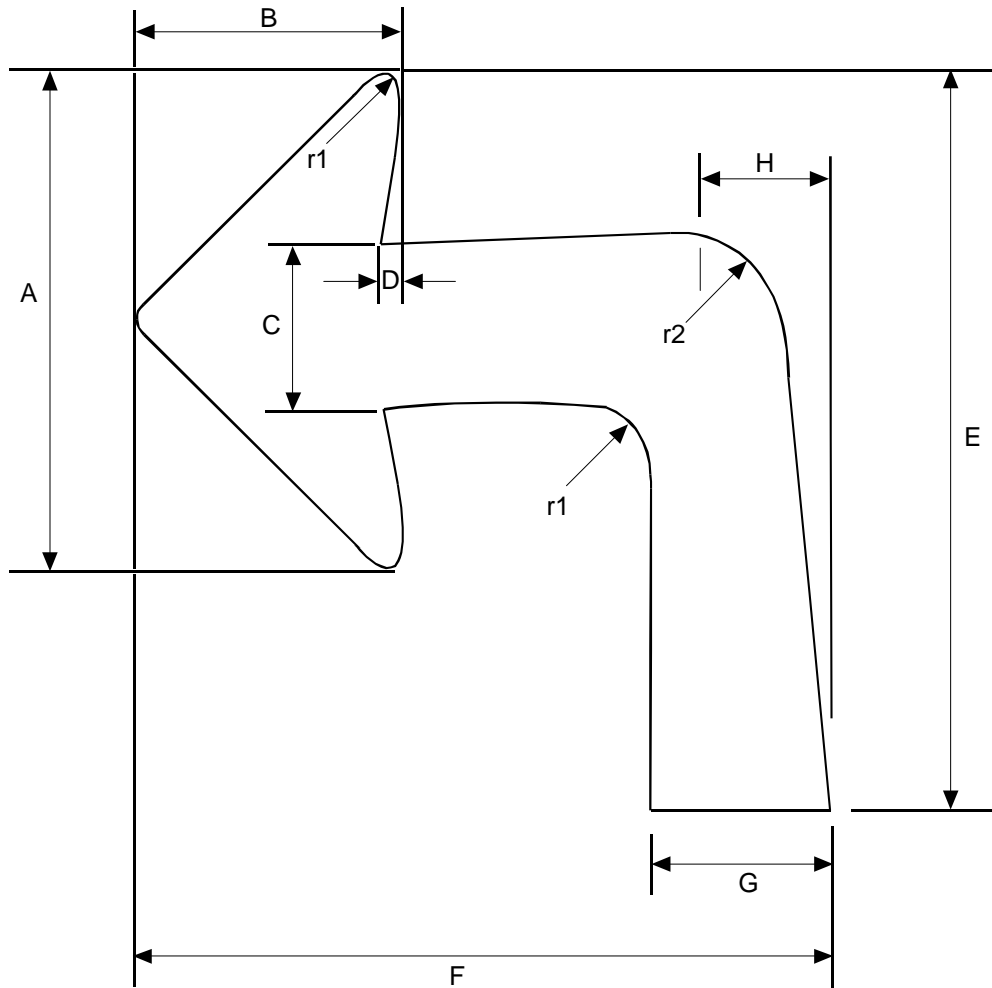

| DIMENSIONS IN (INCHES) | | | | | | | | | | |
|------------------------|--------|-------|-------|-------|--------|--------|-------|-------|-----|-------|
| LETTER SIZE | A | B | C | D | E | F | G | H | r1 | r2 |
| 6 U.C. 4 1/2 L.C. | 8 1/2 | 5 3/4 | 2 | 5/8 | 13 1/2 | 13 | 3 1/2 | 2 1/2 | 3/8 | 2 |
| 8 U.C. 6 L.C. | 14 1/4 | 9 7/8 | 3 3/8 | 1 1/4 | 17 1/4 | 17 1/4 | 5 | 3 1/2 | 3/4 | 2 3/4 |
| 10 2/3 U.C. 8 L.C. | 18 1/4 | 14 | 4 1/2 | 1 1/2 | 24 | 23 | 6 | 4 | 3/4 | 3 |

APPENDIX C

C-1 to C-11

Appendix C. Standard Alphabet

Appendix C. Standard Alphabet

Use Federal Highway Administration “Series 2000” typefaces for all signs except the following:

- All green-on-white direction signs (D and E series) except D3-1, D3-1A, and D3-1D, unless marked otherwise.
- D7-1, D7-2, D7-100
- Signs for which the ClearView typeface is specified. (Clearview is specified on sign drawings by appending “-5W” or “-5WR” to the letter height. For example, a 10 inch Clearview typeface would be shown as “10-5W” or 10-5WR”.

Use Clearview 5W typefaces for these signs unless it is critical to minimize sign width, in which case use Clearview 5WR

“Series 2000” typeface shapes and sizes are defined in the “Standard Alphabets” section of the 2004 *Standard Highway Signs* manual (FHWA).

Clearview 5W and 5WR sizes and shapes are defined in the following tables and graphics (obtained from the FHWA Clearview web site). Characters are identical in the 5W and 5WR series – the only difference is the smaller spacing between characters in the 5WR series. The 5W series results in legend widths around 8% wider than the E-modified typeface historically used for guide signs while the 5WR series results in legends 2 – 3% wider. Studies have shown Clearview fonts to be easier to read than traditional highway sign typefaces.

Appendix C. Standard Alphabet

| Clearview 5W | | | | | | | |
|---|------------|------------|-------------|-----------|------------|------------|-------------|
| Measurements based on 4 inch upper case letter height-prorate for other heights | | | | | | | |
| Character | Left Space | Char Width | Right Space | Character | Left Space | Char Width | Right Space |
| A | 0.36 | 3.76 | 0.36 | o | 0.6 | 3.08 | 0.6 |
| B | 0.8 | 3.04 | 0.6 | p | 0.76 | 2.92 | 0.6 |
| C | 0.64 | 3.28 | 0.44 | q | 0.6 | 3.2 | 0.48 |
| D | 0.8 | 3.24 | 0.64 | r | 0.76 | 1.84 | 0.4 |
| E | 0.8 | 2.56 | 0.56 | s | 0.44 | 2.56 | 0.52 |
| F | 0.8 | 2.44 | 0.52 | t | 0.36 | 1.96 | 0.44 |
| G | 0.64 | 3.48 | 0.64 | u | 0.76 | 2.72 | 0.76 |
| H | 0.8 | 3.08 | 0.8 | v | 0.28 | 3.04 | 0.28 |
| I | 0.8 | 0.8 | 0.8 | w | 0.32 | 4.64 | 0.32 |
| J | 0.32 | 2.24 | 0.8 | x | 0.24 | 3.08 | 0.24 |
| K | 0.8 | 3.12 | 0.36 | y | 0.28 | 3.12 | 0.28 |
| L | 0.8 | 2.36 | 0.48 | z | 0.48 | 2.44 | 0.48 |
| M | 0.8 | 3.68 | 0.8 | 1 | 0.4 | 1.8 | 0.8 |
| N | 0.8 | 3.32 | 0.8 | 2 | 0.48 | 2.76 | 0.64 |
| O | 0.64 | 3.72 | 0.64 | 3 | 0.44 | 2.8 | 0.64 |
| P | 0.8 | 2.92 | 0.48 | 4 | 0.48 | 3.16 | 0.52 |
| Q | 0.64 | 3.72 | 0.64 | 5 | 0.6 | 2.76 | 0.64 |
| R | 0.8 | 3 | 0.6 | 6 | 0.64 | 2.92 | 0.6 |
| S | 0.48 | 2.88 | 0.52 | 7 | 0.4 | 2.84 | 0.4 |
| T | 0.4 | 2.88 | 0.4 | 8 | 0.64 | 2.92 | 0.64 |
| U | 0.8 | 3.12 | 0.8 | 9 | 0.6 | 2.92 | 0.64 |
| V | 0.36 | 3.4 | 0.36 | 0 | 0.68 | 3.28 | 0.68 |
| W | 0.4 | 5.32 | 0.4 | & | 0.64 | 3.44 | 0.4 |
| X | 0.32 | 3.44 | 0.32 | ! | 0.72 | 1 | 0.72 |
| Y | 0.28 | 3.52 | 0.28 | " | 0.56 | 2.16 | 0.56 |
| Z | 0.52 | 2.88 | 0.52 | # | 0.56 | 3.44 | 0.56 |
| a | 0.52 | 2.96 | 0.52 | \$ | 0.48 | 2.72 | 0.48 |
| b | 0.76 | 2.88 | 0.6 | ¢ | 0.6 | 2.6 | 0.4 |
| c | 0.6 | 2.72 | 0.4 | / | 0.44 | 2.88 | 0.44 |
| d | 0.6 | 2.92 | 0.76 | * | 0.6 | 1.92 | 0.6 |
| e | 0.6 | 2.96 | 0.6 | . | 0.56 | 1 | 0.56 |
| f | 0.44 | 1.92 | 0.4 | , | 0.52 | 1.08 | 0.52 |
| g | 0.6 | 2.92 | 0.76 | : | 0.56 | 1 | 0.56 |
| h | 0.76 | 2.76 | 0.76 | (| 0.6 | 1.08 | 0.6 |
| i | 0.68 | 0.92 | 0.68 |) | 0.6 | 1.08 | 0.6 |
| j | -0.12 | 1.76 | 0.68 | - | 0.8 | 1.56 | 0.8 |
| k | 0.76 | 2.84 | 0.28 | @ | 0.64 | 4.04 | 0.64 |
| l | 0.76 | 1.28 | 0.44 | = | 0.72 | 2.4 | 0.72 |
| m | 0.76 | 4.52 | 0.76 | + | 0.6 | 2.68 | 0.6 |
| n | 0.76 | 2.76 | 0.76 | ? | 0.56 | 2.56 | 0.56 |

Appendix C. Standard Alphabet

| Clearview 5WR | | | | | | | |
|---|------------|------------|-------------|-----------|------------|------------|-------------|
| Measurements based on 4 inch upper case letter height-prorate for other heights | | | | | | | |
| Character | Left Space | Char Width | Right Space | Character | Left Space | Char Width | Right Space |
| A | 0.24 | 3.76 | 0.24 | o | 0.48 | 3.08 | 0.48 |
| B | 0.68 | 3.04 | 0.48 | p | 0.64 | 2.92 | 0.48 |
| C | 0.52 | 3.28 | 0.32 | q | 0.48 | 3.2 | 0.36 |
| D | 0.68 | 3.24 | 0.52 | r | 0.64 | 1.84 | 0.28 |
| E | 0.68 | 2.56 | 0.44 | s | 0.28 | 2.56 | 0.4 |
| F | 0.68 | 2.44 | 0.4 | t | 0.24 | 1.96 | 0.36 |
| G | 0.52 | 3.48 | 0.52 | u | 0.64 | 2.72 | 0.64 |
| H | 0.8 | 3.08 | 0.8 | v | 0.16 | 3.04 | 0.16 |
| I | 0.68 | 0.8 | 0.68 | w | 0.2 | 4.64 | 0.2 |
| J | 0.2 | 2.24 | 0.68 | x | 0.12 | 3.08 | 0.12 |
| K | 0.68 | 3.12 | 0.24 | y | 0.16 | 3.12 | 0.16 |
| L | 0.68 | 2.36 | 0.36 | z | 0.36 | 2.44 | 0.36 |
| M | 0.68 | 3.68 | 0.68 | 1 | 0.28 | 1.8 | 0.68 |
| N | 0.68 | 3.32 | 0.68 | 2 | 0.36 | 2.76 | 0.52 |
| O | 0.52 | 3.72 | 0.52 | 3 | 0.32 | 2.8 | 0.52 |
| P | 0.68 | 2.92 | 0.36 | 4 | 0.36 | 3.16 | 0.4 |
| Q | 0.52 | 3.72 | 0.52 | 5 | 0.48 | 2.76 | 0.52 |
| R | 0.68 | 3 | 0.48 | 6 | 0.52 | 2.92 | 0.48 |
| S | 0.36 | 2.88 | 0.4 | 7 | 0.28 | 2.84 | 0.28 |
| T | 0.28 | 2.88 | 0.28 | 8 | 0.52 | 2.92 | 0.52 |
| U | 0.68 | 3.12 | 0.68 | 9 | 0.48 | 2.92 | 0.52 |
| V | 0.24 | 3.4 | 0.24 | 0 | 0.56 | 3.28 | 0.56 |
| W | 0.28 | 5.32 | 0.28 | & | 0.52 | 3.44 | 0.28 |
| X | 0.2 | 3.44 | 0.2 | ! | 0.6 | 1 | 0.6 |
| Y | 0.16 | 3.52 | 0.16 | " | 0.44 | 2.16 | 0.44 |
| Z | 0.4 | 2.88 | 0.4 | # | 0.44 | 3.44 | 0.44 |
| a | 0.4 | 2.96 | 0.4 | \$ | 0.36 | 2.72 | 0.36 |
| b | 0.64 | 2.88 | 0.48 | ¢ | 0.48 | 2.6 | 0.28 |
| c | 0.48 | 2.72 | 0.28 | / | 0.32 | 2.88 | 0.32 |
| d | 0.48 | 2.92 | 0.64 | * | 0.48 | 1.92 | 0.48 |
| e | 0.48 | 2.96 | 0.48 | . | 0.44 | 1 | 0.44 |
| f | 0.32 | 1.92 | 0.28 | , | 0.4 | 1.08 | 0.4 |
| g | 0.48 | 2.92 | 0.64 | : | 0.44 | 1 | 0.44 |
| h | 0.64 | 2.76 | 0.64 | (| 0.48 | 1.08 | 0.48 |
| i | 0.56 | 0.92 | 0.56 |) | 0.48 | 1.08 | 0.48 |
| j | -0.24 | 1.76 | 0.56 | - | 0.6 | 1.56 | 0.6 |
| k | 0.64 | 2.84 | 0.16 | @ | 0.52 | 4.04 | 0.52 |
| l | 0.64 | 1.28 | 0.32 | = | 0.6 | 2.4 | 0.6 |
| m | 0.64 | 4.52 | 0.64 | + | 0.48 | 2.68 | 0.48 |
| n | 0.64 | 2.76 | 0.64 | ? | 0.44 | 2.56 | 0.44 |

Appendix C. Standard Alphabet



Appendix C. Standard Alphabet

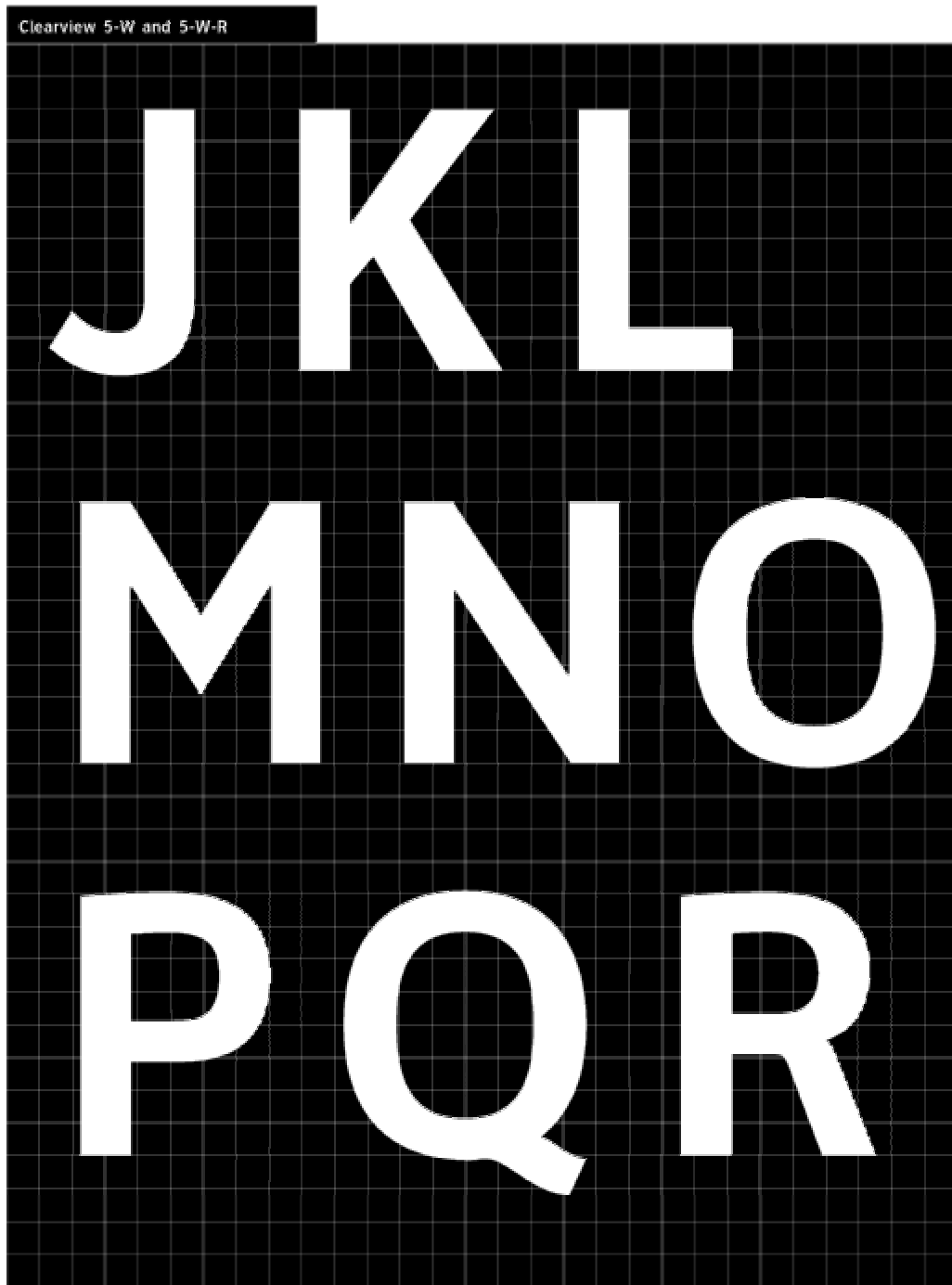

Appendix C. Standard Alphabet

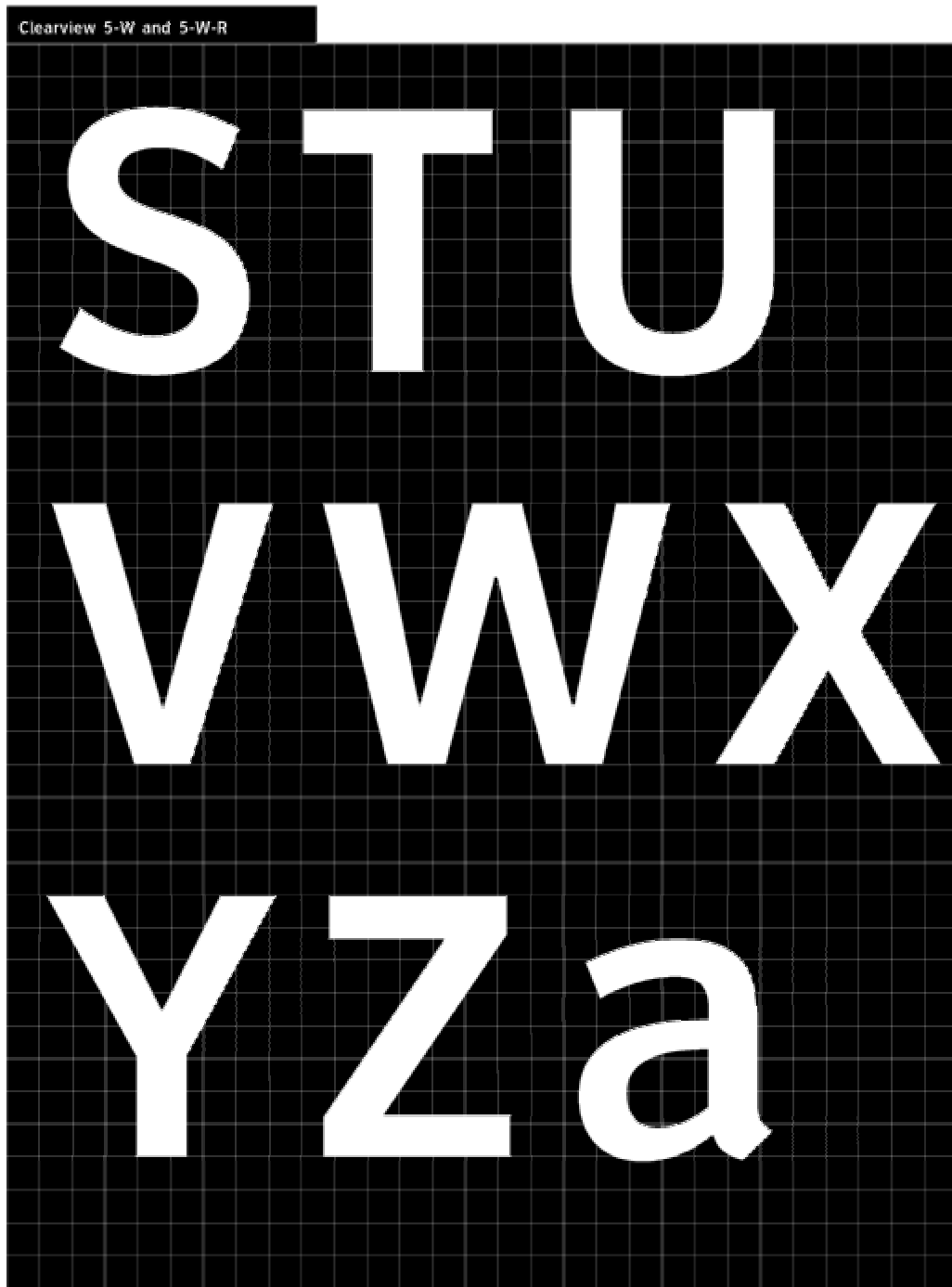

Appendix C. Standard Alphabet



Appendix C. Standard Alphabet



Appendix C. Standard Alphabet

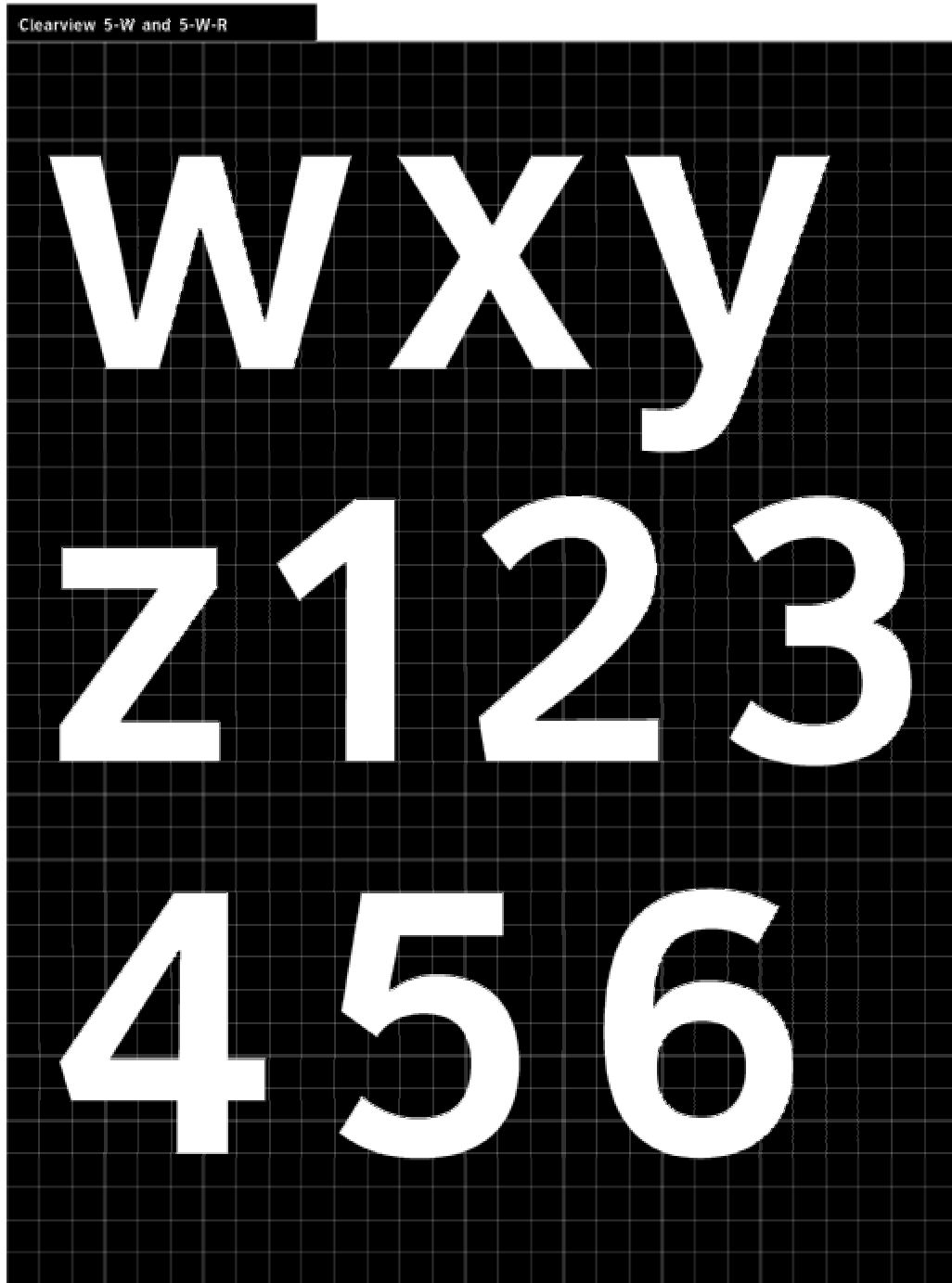

Appendix C. Standard Alphabet



Appendix C. Standard Alphabet

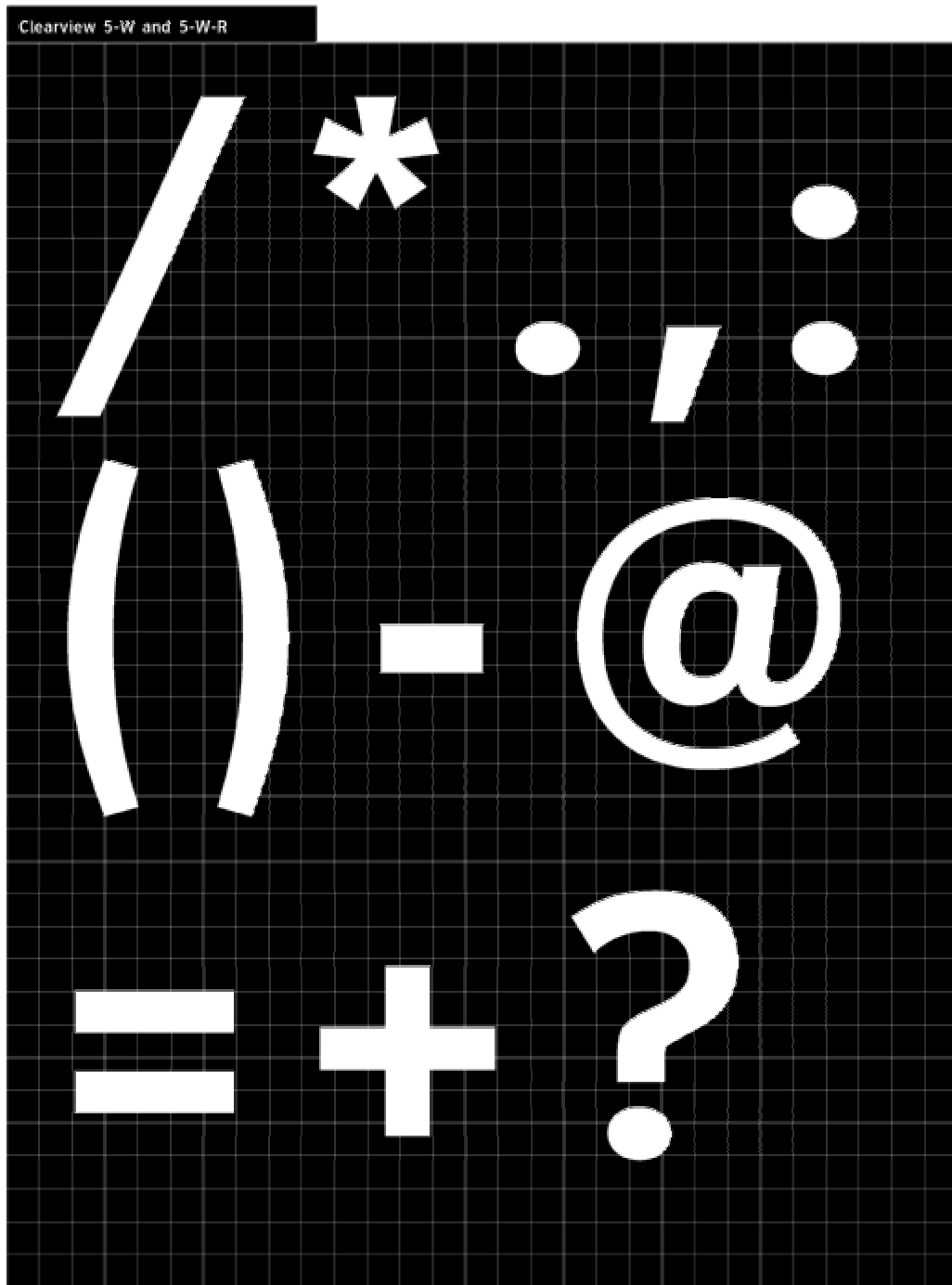

APPENDIX D

D-1 to D-5

Appendix D. Sign Blank Details

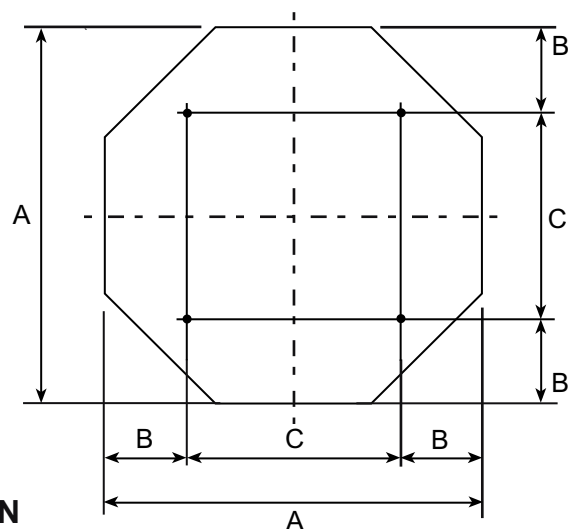
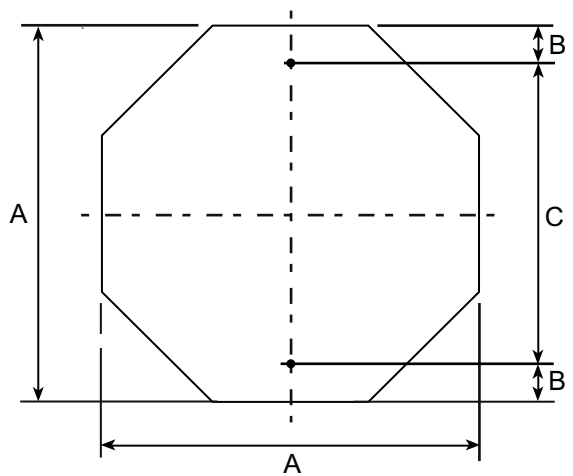

OCTAGON

| A | B | C |
|----|---|----|
| 24 | 3 | 18 |
| 30 | 3 | 24 |
| 36 | 3 | 30 |

| A | B | C |
|----|---|----|
| 48 | 9 | 30 |

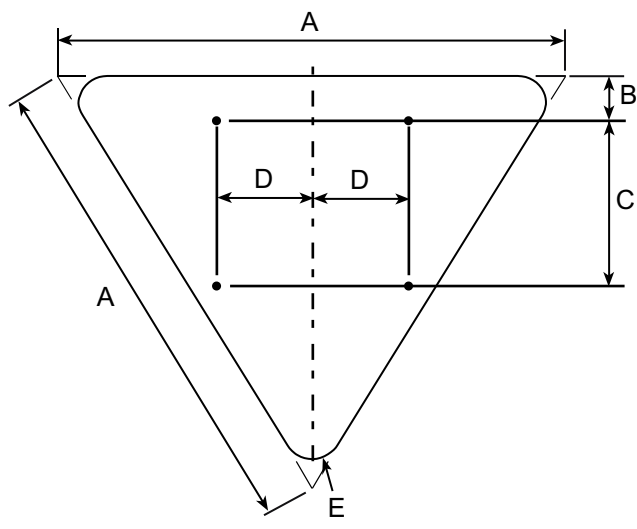
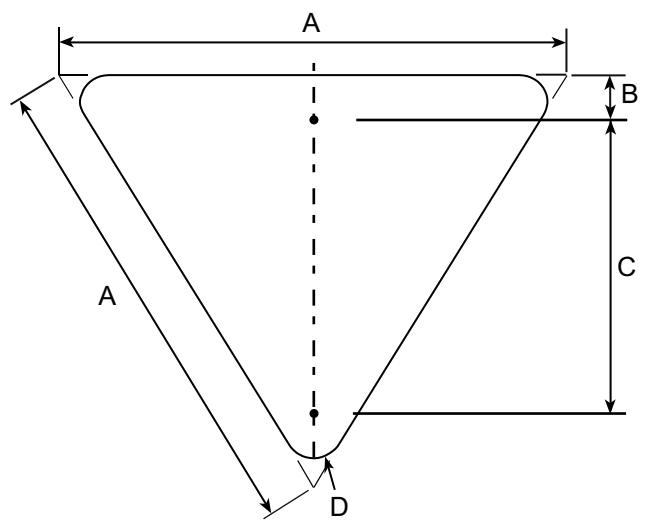

EQUILATERAL TRIANGLE

| A | B | C | D |
|----|---|----|-----|
| 30 | 3 | 18 | 1.5 |
| 36 | 3 | 21 | 2.0 |

| A | B | C | D | E |
|----|---|----|----|---|
| 48 | 3 | 12 | 12 | 3 |
| 60 | 3 | 18 | 15 | 4 |

Appendix D. Sign Blank Details

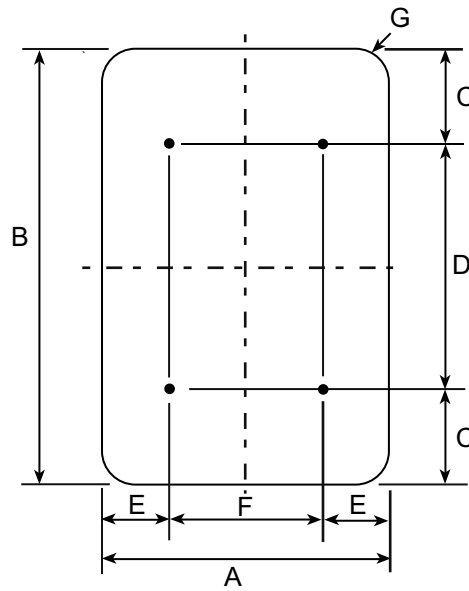
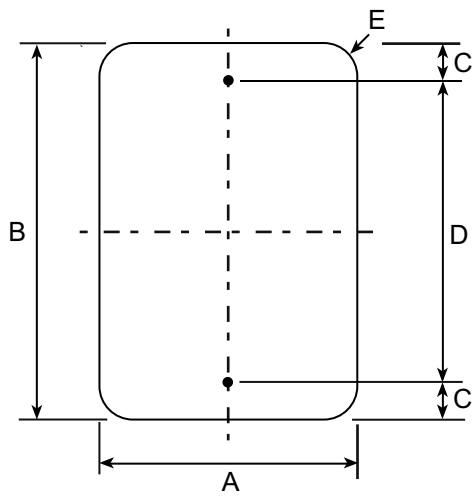

VERTICAL RECTANGLE

| A | B | C | D | C |
|----|----|-----|----|------|
| 12 | 18 | 1.5 | 15 | 1.50 |
| 18 | 24 | 3 | 18 | 1.50 |
| 24 | 30 | 3 | 24 | 1.50 |
| 30 | 36 | 3 | 30 | 1.88 |

| A | B | C | D | E | F | G |
|----|----|---|----|---|----|------|
| 36 | 48 | 6 | 36 | 6 | 24 | 2.25 |
| 48 | 60 | 6 | 48 | 9 | 30 | 3.00 |

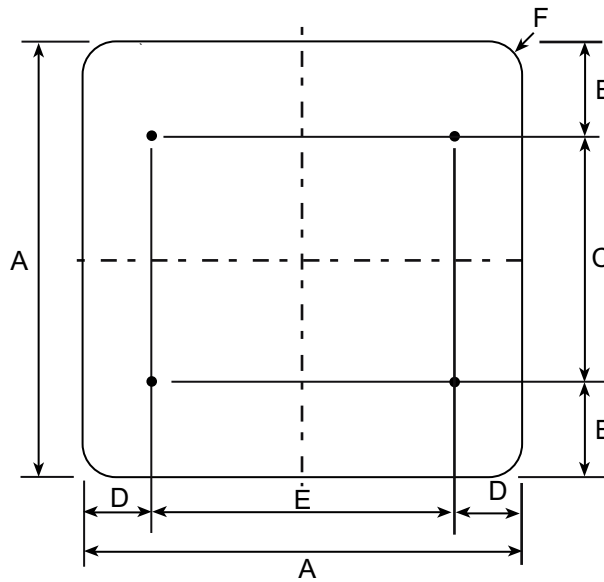
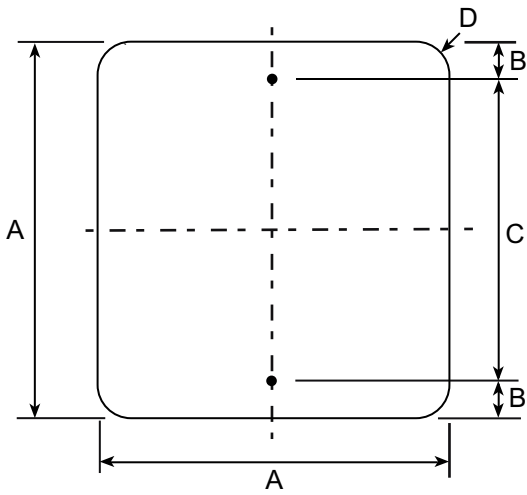

SQUARE

| A | B | C | D |
|----|---|----|------|
| 18 | 3 | 12 | 1.50 |
| 24 | 3 | 18 | 1.50 |
| 30 | 3 | 24 | 1.88 |

| A | B | C | D | E | F |
|----|---|----|---|----|------|
| 36 | 6 | 24 | 6 | 24 | 2.25 |
| 48 | 6 | 36 | 9 | 30 | 3.00 |

Appendix D. Sign Blank Details

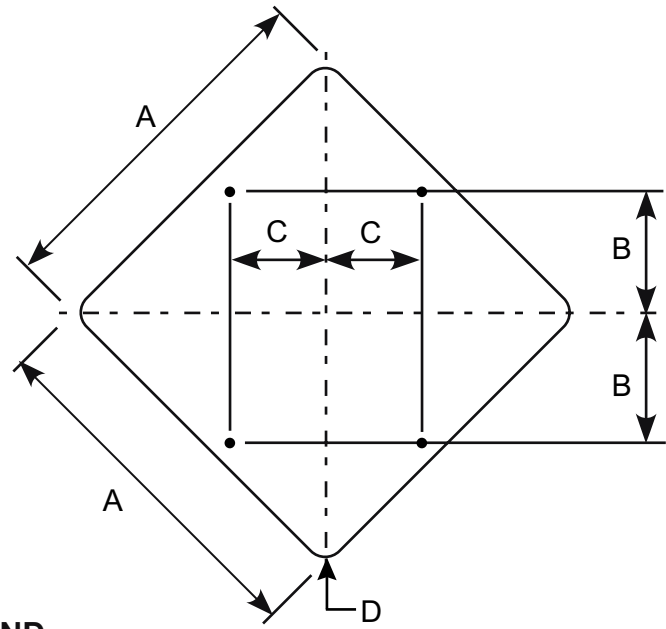
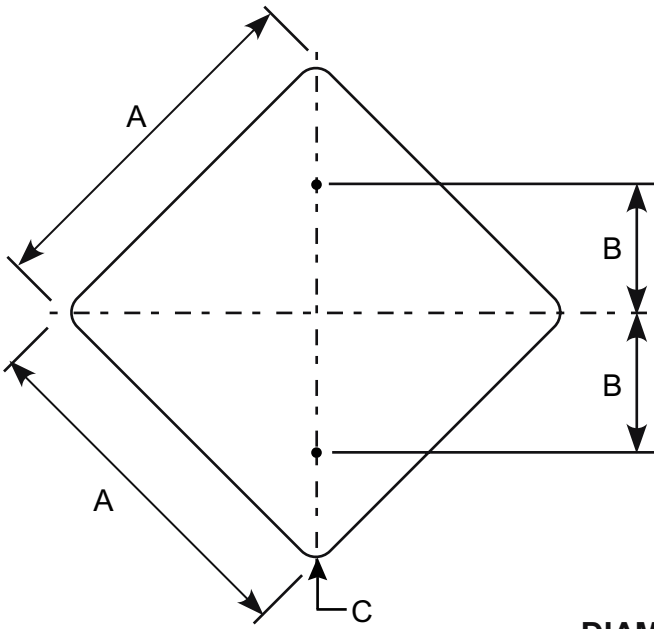

DIAMOND

| A | B | C |
|----|----|------|
| 24 | 12 | 1.50 |
| 30 | 15 | 1.88 |
| 36 | 18 | 2.25 |

| A | B | C | D |
|----|----|----|------|
| 48 | 15 | 15 | 3.00 |
| 60 | 18 | 18 | 3.75 |

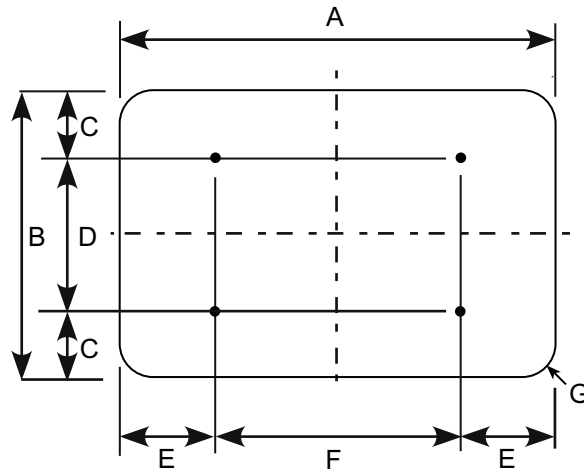
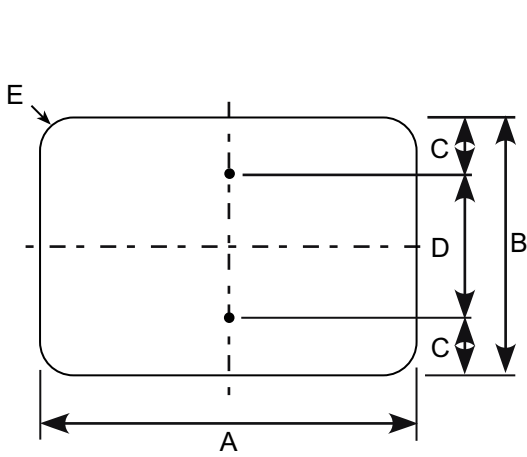

HORIZONTAL RECTANGLE

| A | B | C | D | E |
|----|----|-----|----|-----|
| 21 | 15 | 1.5 | 12 | 1.5 |
| 24 | 12 | 1.5 | 9 | 1.5 |
| 24 | 18 | 3.0 | 12 | 1.5 |
| 30 | 15 | 1.5 | 12 | 1.5 |
| 30 | 24 | 3.0 | 18 | 1.5 |
| 36 | 12 | 1.5 | 9 | 1.5 |

| A | B | C | D | E | F | G |
|----|----|---|----|----|----|------|
| 36 | 24 | 3 | 18 | 6 | 24 | 1.50 |
| 48 | 24 | 3 | 18 | 9 | 30 | 1.88 |
| 48 | 36 | 6 | 24 | 9 | 30 | 2.25 |
| 60 | 24 | 3 | 18 | 12 | 36 | 1.50 |
| 60 | 36 | 6 | 24 | 12 | 36 | 2.25 |

Appendix D. Sign Blank Details

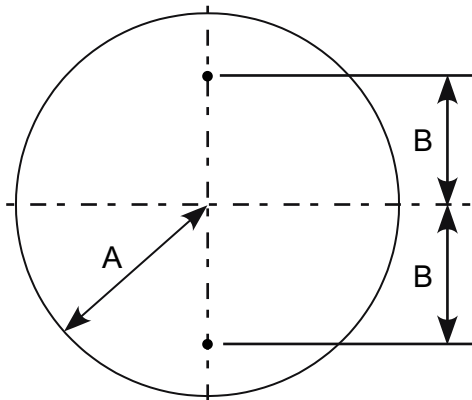

CIRCLE

| A | B |
|----|----|
| 15 | 12 |
| 18 | 15 |

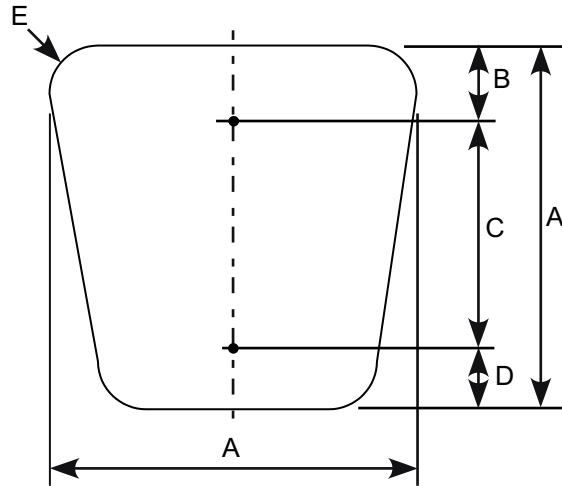

NATIONAL FOREST SHIELD

| A | B | C | D | E |
|----|-----|----|-----|-----|
| 18 | 2.0 | 15 | 1.0 | 2.0 |
| 24 | 2.5 | 20 | 1.5 | 2.5 |

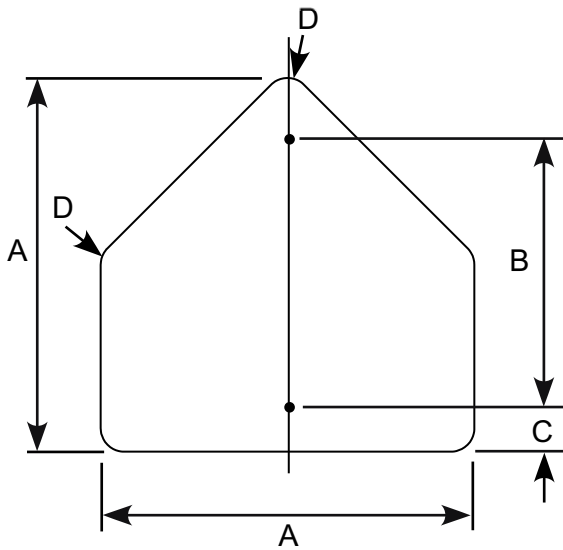

PENTAGON (SCHOOL)

| A | B | C | D |
|----|----|---|------|
| 30 | 21 | 3 | 1.88 |
| 36 | 24 | 3 | 2.25 |

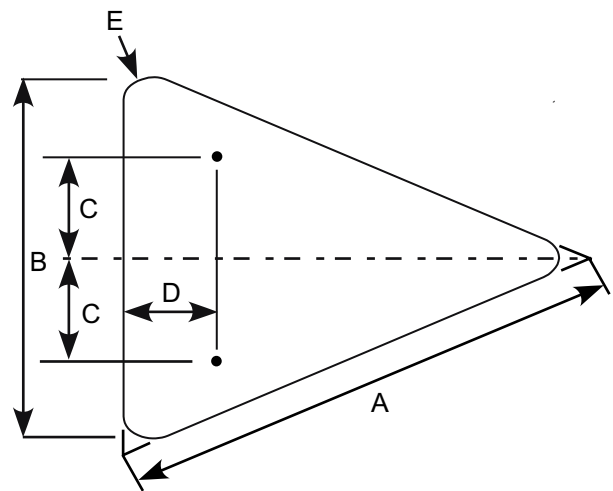

ISOSCELES TRIANGLE

| A | B | C | D | E |
|----|----|------|------|------|
| 40 | 30 | 7.5 | 12.0 | 1.88 |
| 48 | 36 | 9.0 | 15.0 | 2.25 |
| 64 | 48 | 12.0 | 20.0 | 3.00 |

Appendix D. Sign Blank Details

Standard Highway Sign Border Specifications

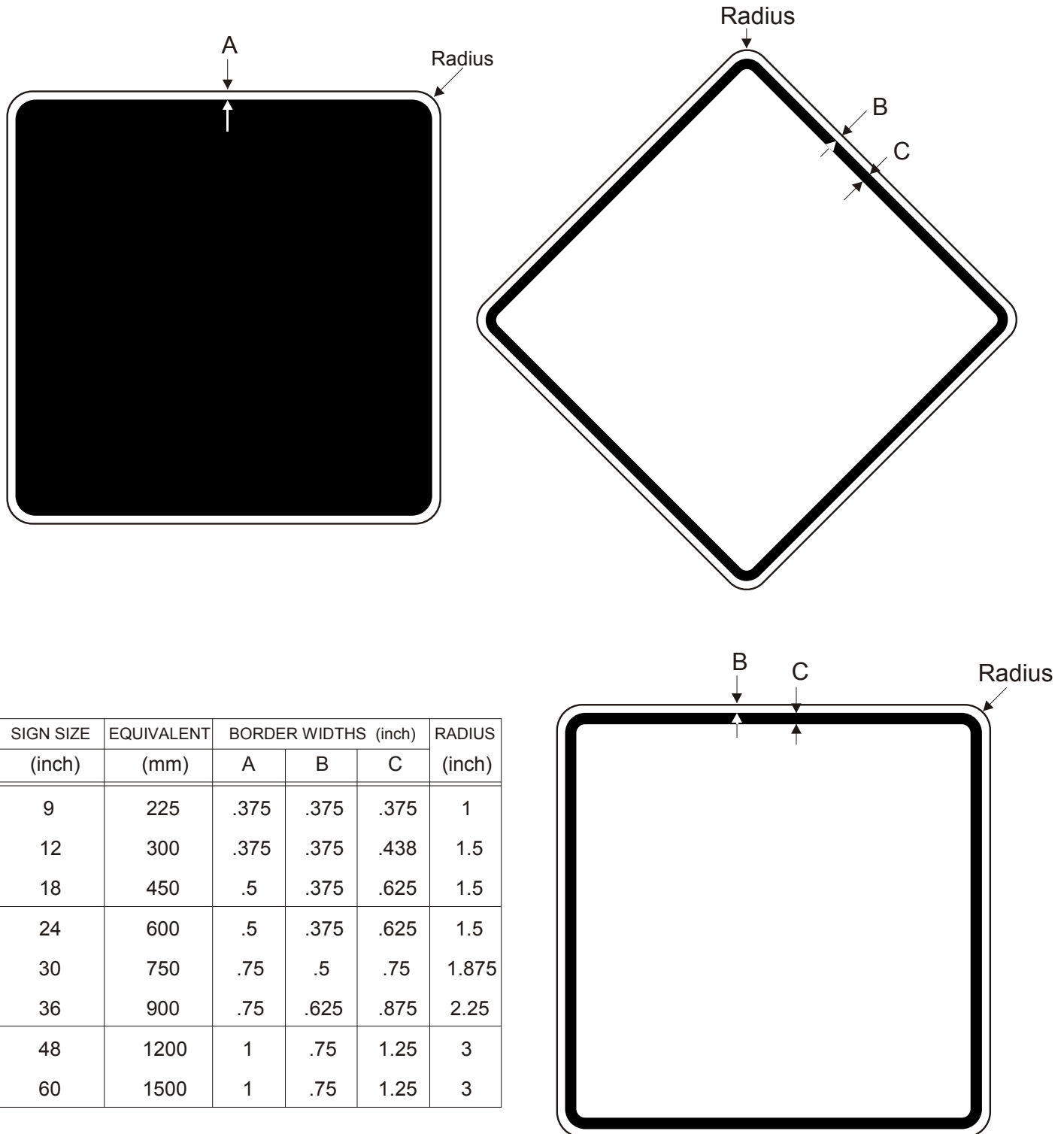

| SIGN SIZE (inch) | EQUIVALENT (mm) | BORDER WIDTHS (inch) | | | RADIUS (inch) |
|---------------------|--------------------|----------------------|------|------|------------------|
| | | A | B | C | |
| 9 | 225 | .375 | .375 | .375 | 1 |
| 12 | 300 | .375 | .375 | .438 | 1.5 |
| 18 | 450 | .5 | .375 | .625 | 1.5 |
| 24 | 600 | .5 | .375 | .625 | 1.5 |
| 30 | 750 | .75 | .5 | .75 | 1.875 |
| 36 | 900 | .75 | .625 | .875 | 2.25 |
| 48 | 1200 | 1 | .75 | 1.25 | 3 |
| 60 | 1500 | 1 | .75 | 1.25 | 3 |

