

**Location:**

**Kateel River Meridian**

**T17N, R18W Section 21, 26, 27, 28, 35, 36**  
**T16N, R18W Section 2, 11, 12, 13**  
**T16N, R17W Section 18, 19, 30, 31**  
**T15N, R17W Section 6**

- Place Name
- ★ Project Location
- Kotzebue Cape Blossom Road
- DOT & PF Road
- Windmill Road
- ~ Stream River
- Waterbody

<b>Vicinity</b>	
<b>Applicant:</b> STATE OF ALASKA Department of Transportation and Public Facilities 2301 Peger Rd. Fairbanks, AK 99709	
Kotzebue to Cape Blossom Road Construction Project	
<b>File No.:</b> POA-2012-272	
<b>Waterway:</b> Kotzebue Sound	
<b>Proposed Activity:</b> Wetland fill for roadway	
<b>Date:</b> June 2017	Sheet 1 of 43

**SUMMARY OF PROPOSED IMPACTS TO WETLANDS AND WATERS OF THE U.S.**

<b>SUMMARY OF PROJECT IMPACTS</b>					
<b>Duration</b>	<b>Disturbance</b>	<b>Wetlands</b>		<b>Below OHW</b>	
		Area (Acres)	Fill (yd <sup>3</sup> )	Area (Acres)	Fill (yd <sup>3</sup> )
<b>Permanent</b>	Roadway / Embankment	107.06	995,000	0.091	1,000
	Culverts	0.13	447	0.015	27
	Culvert Riprap	0.08	264	0.004	12
	Bridge Riprap	0.14	456	0.017	54
	Bridge Piers	N/A	N/A	0.001	20
	<b><u>Permanent Impact Total</u></b>		<b>107.41</b>	<b>996,167</b>	<b>0.128</b>
<b>Temporary</b>	Work Zone	27.77	N/A	0.046	N/A
	Vegetative Buffer	69.65	N/A	0.073	N/A
	Bridge Work Zone	0.29	N/A	0.388	N/A
	<b><u>Temporary Impact Total</u></b>	<b>97.71</b>	<b>0</b>	<b>0.507</b>	<b>0</b>
<b>All</b>	<b><u>TOTAL</u></b>	<b><u>205.12</u></b>	<b><u>996,167</u></b>	<b><u>0.63</u></b>	<b><u>1,113</u></b>

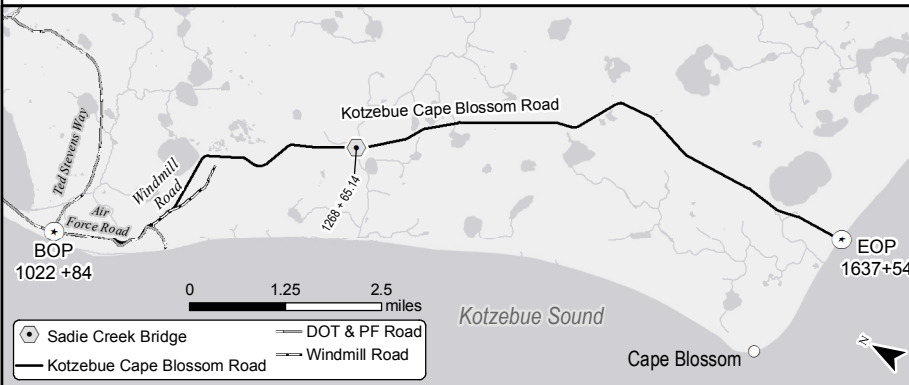

<b>Impact Summary</b>	
<b>Applicant:</b> STATE OF ALASKA Department of Transportation and Public Facilities 2301 Peger Rd. Fairbanks, AK 99709	
Kotzebue to Cape Blossom Road Construction Project	
<b>File No.:</b> POA-2012-272	
<b>Waterway:</b> Kotzebue Sound	
<b>Proposed Activity:</b> Wetland fill for roadway	
<b>Date:</b> June 2017	Sheet 2 of 43

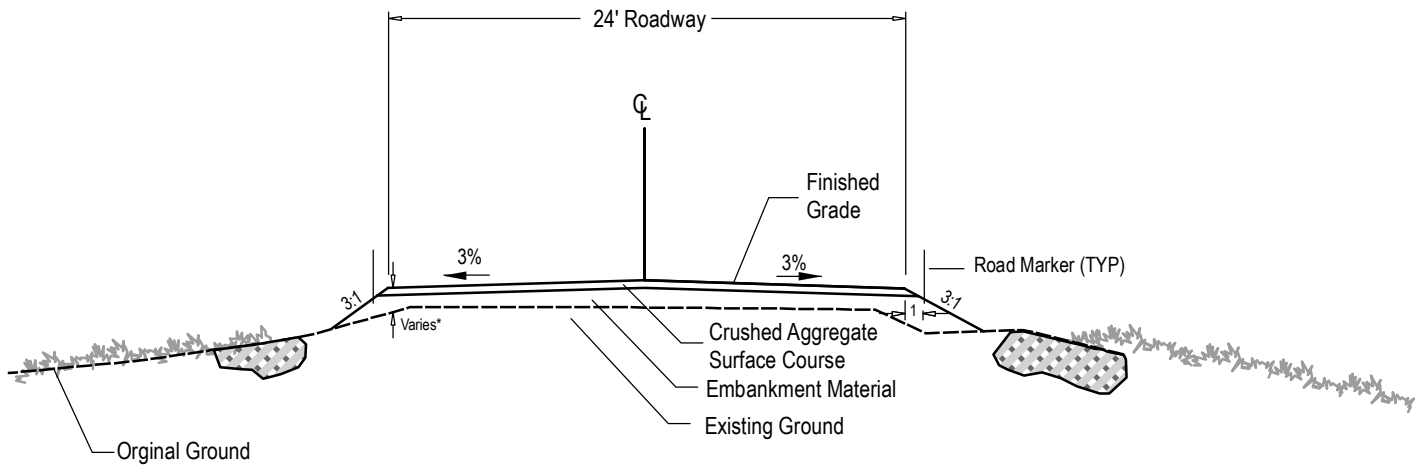

Typical Section  
Not to Scale

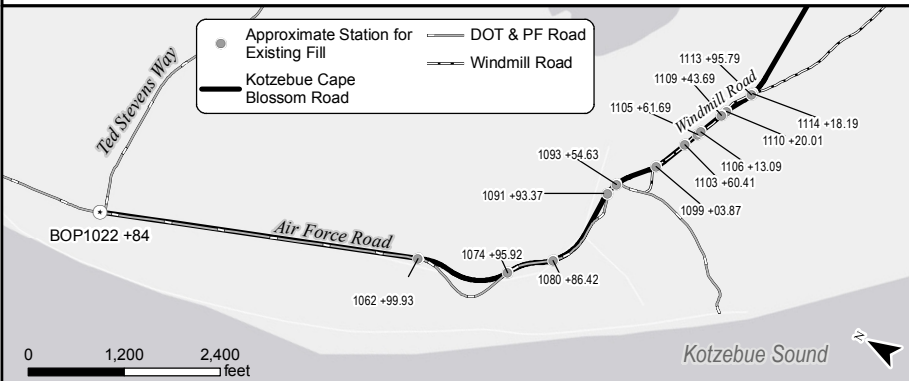

**Road Reconstruction Detail**

**Applicant:**  
STATE OF ALASKA  
Department of Transportation and Public Facilities  
2301 Peger Rd. Fairbanks, AK 99709

Kotzebue to Cape Blossom  
Road Construction Project

**File No.:** POA-2012-272

**Waterway:** Kotzebue Sound

**Proposed Activity:** Wetland fill for roadway

**Date:** June 2017

Sheet 3 of 43

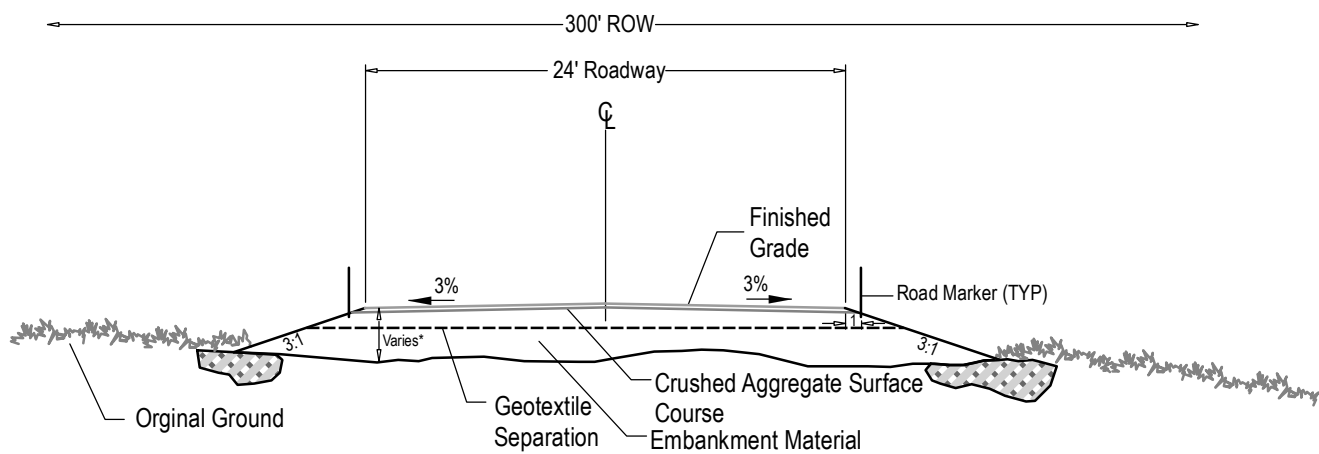

\* Embankment height will vary, averaging 8 feet.

Embankment height may vary in areas of potential snow drifting or in areas where there is concern of thawing underlying permafrost.

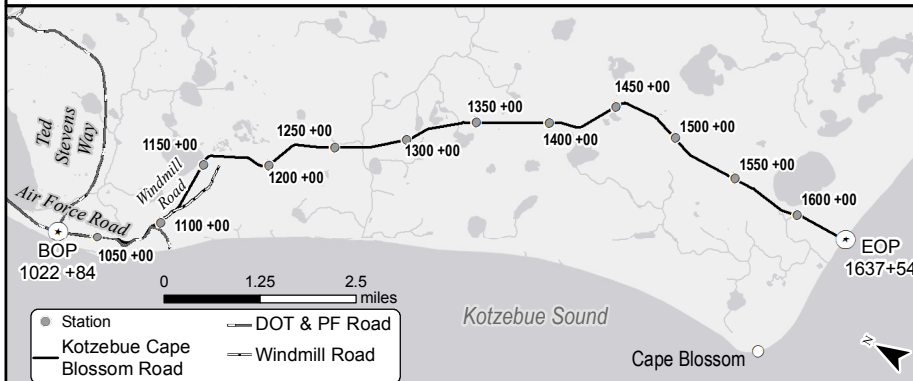

**Road Construction Detail**

**Applicant:**  
STATE OF ALASKA  
Department of Transportation and Public Facilities  
2301 Peger Rd. Fairbanks, AK 99709

Kotzebue to Cape Blossom  
Road Construction Project

**File No.:** POA-2012-272

**Waterway:** Kotzebue Sound

**Proposed Activity:** Wetland fill for roadway

**Date:** June 2017

Sheet 4 of 43

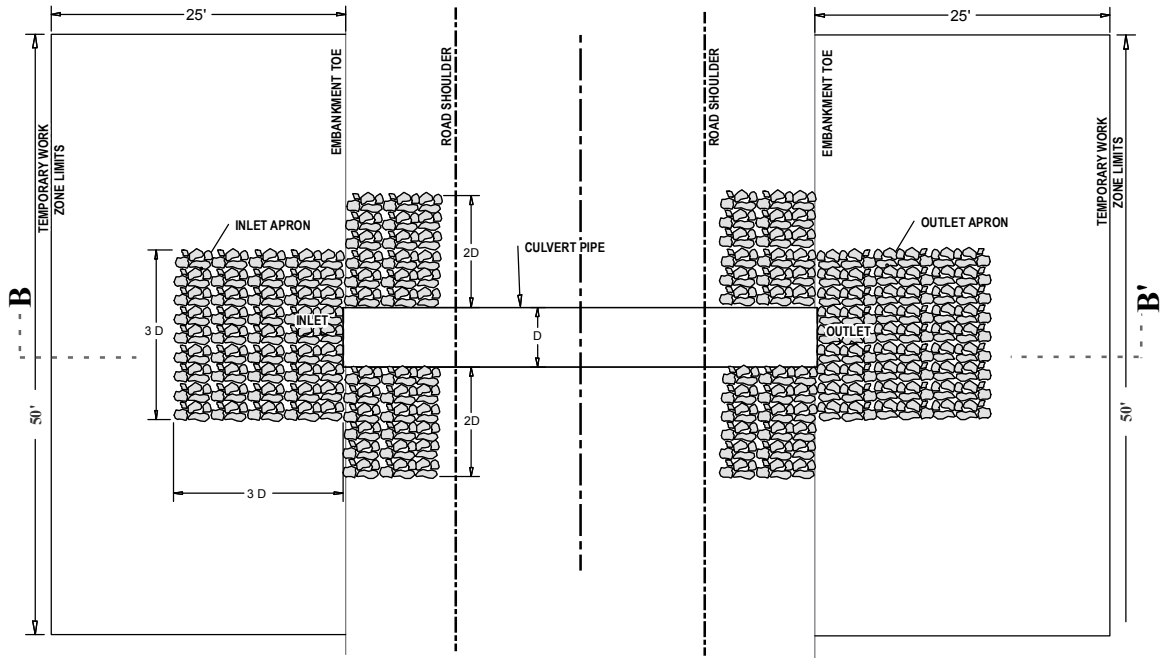

**TYPICAL CULVERT APRON DETAIL**  
NOT TO SCALE

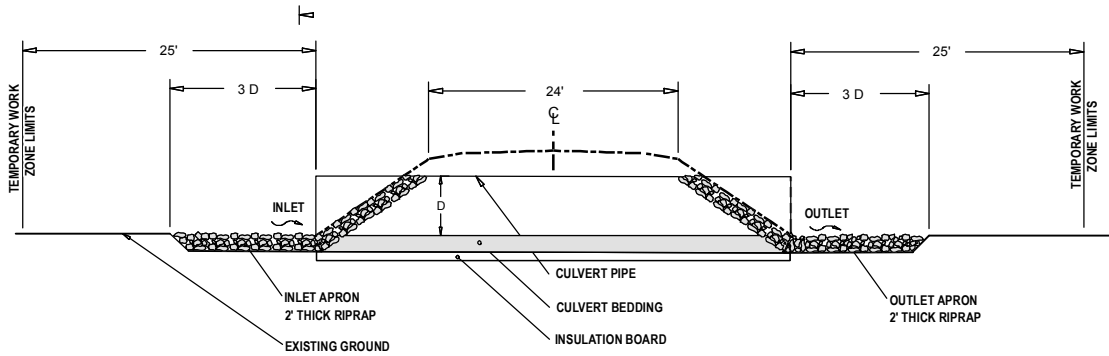

**SECTION B-B'**  
NOT TO SCALE

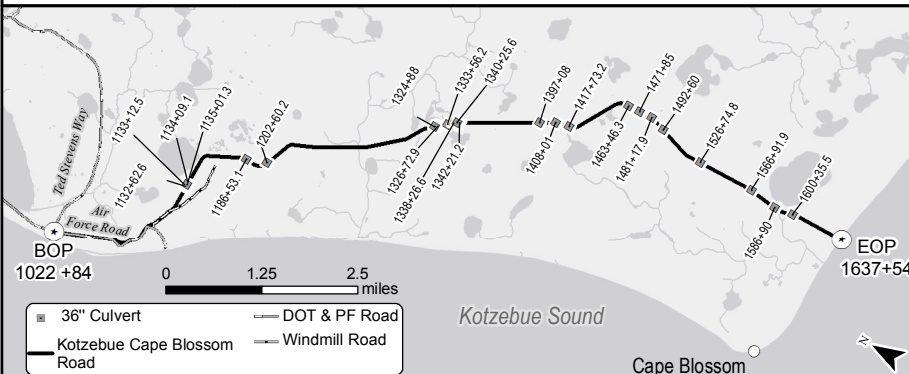

**Culvert Detail**

**Applicant:**  
STATE OF ALASKA  
Department of Transportation and Public Facilities  
2301 Peger Rd. Fairbanks, AK 99709

Kotzebue to Cape Blossom  
Road Construction Project

**File No.:** POA-2012-272

**Waterway:** Kotzebue Sound

**Proposed Activity:** Wetland fill for roadway

**Date:** June 2017

Sheet 5 of 43

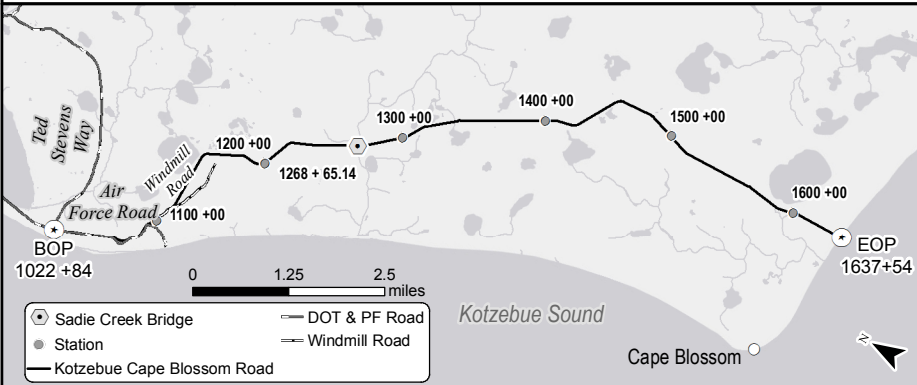
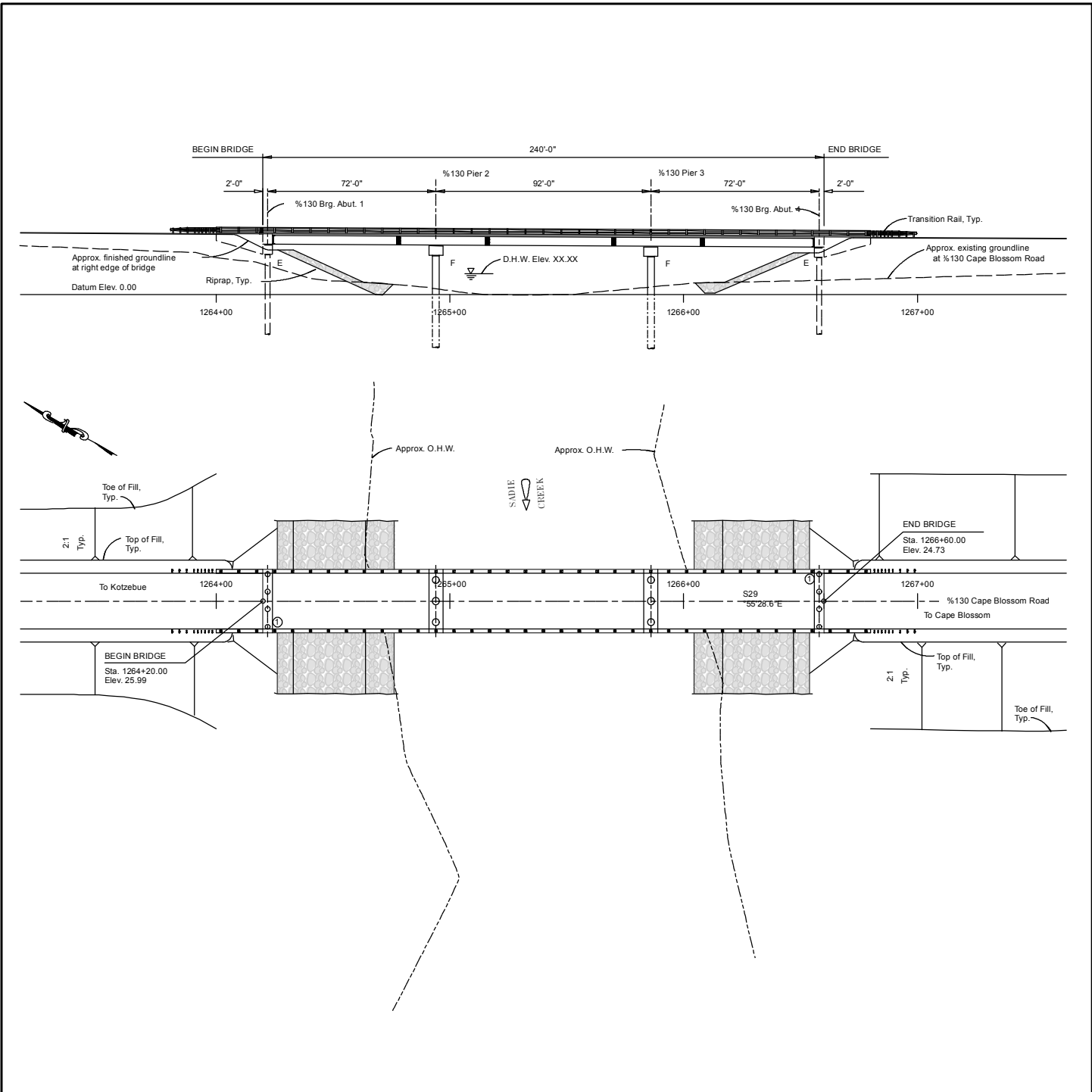

<b>Bridge Detail</b>	
<b>Applicant:</b> STATE OF ALASKA Department of Transportation and Public Facilities 2301 Peger Rd. Fairbanks, AK 99709	
Kotzebue to Cape Blossom Road Construction Project	
<b>File No.:</b> POA-2012-272	
<b>Waterway:</b> Kotzebue Sound	
<b>Proposed Activity:</b> Wetland fill for roadway	
<b>Date:</b> June 2017	Sheet 6 of 43

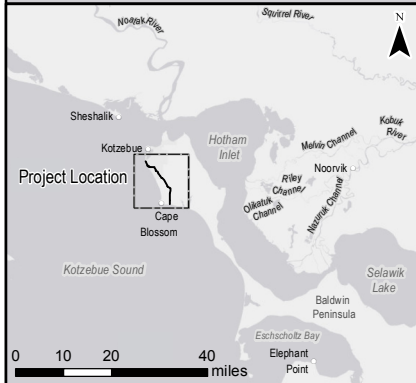
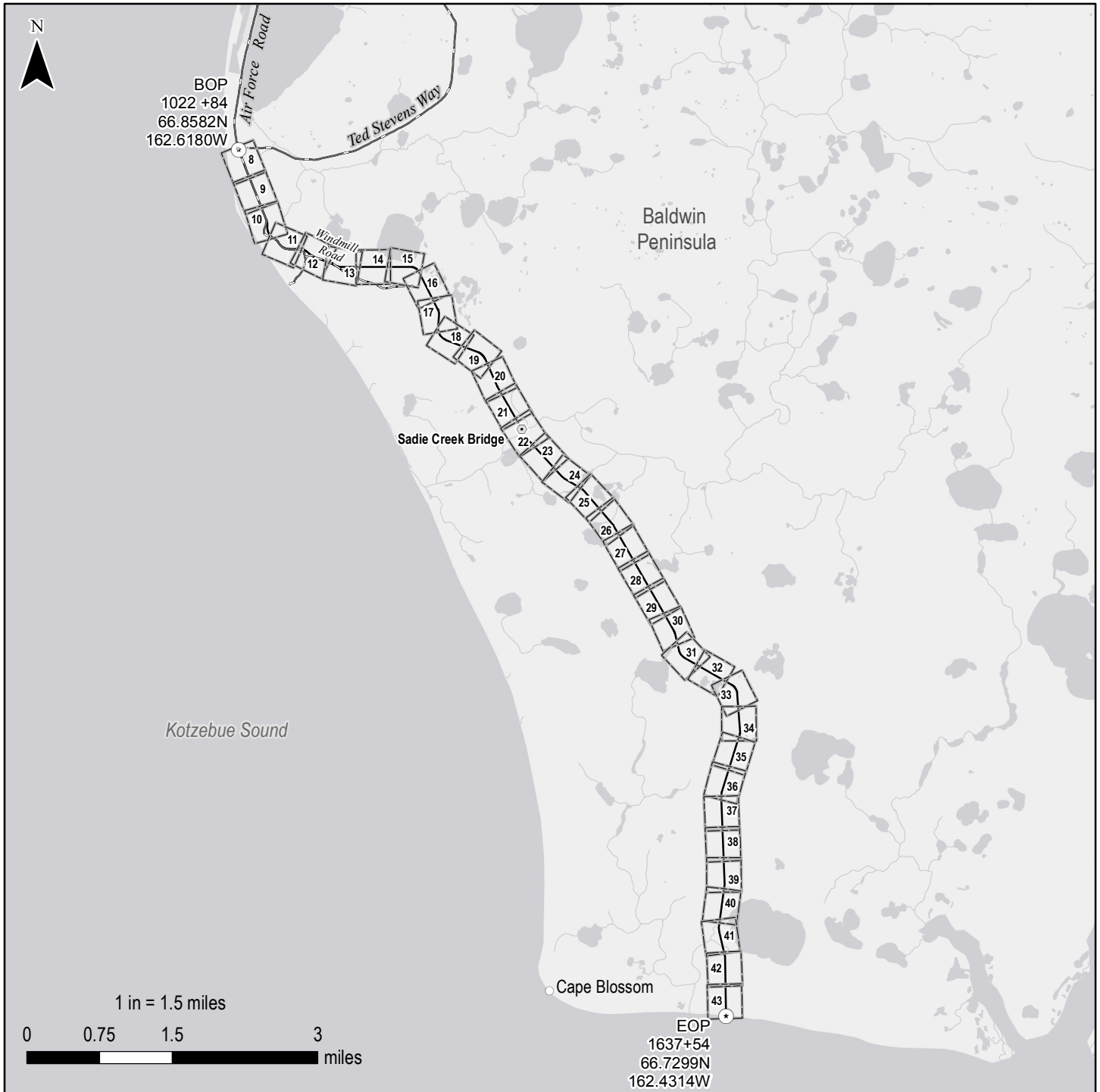

- Place Name
- ⊙ Project Location
- Page Index
- Waterbody
- DOT & PF Road
- Windmill Road
- Kotzebue Cape Blossom Road
- ~ Stream River

<b>Plan View</b>	
<b>Applicant:</b> STATE OF ALASKA Department of Transportation and Public Facilities 2301 Peger Rd. Fairbanks, AK 99709	
Kotzebue to Cape Blossom Road Construction Project	
<b>File No.:</b> POA-2012-272	
<b>Waterway:</b> Kotzebue Sound	
<b>Proposed Activity:</b> Wetland fill for roadway	
<b>Date:</b> June 2017	Sheet 7 of 43

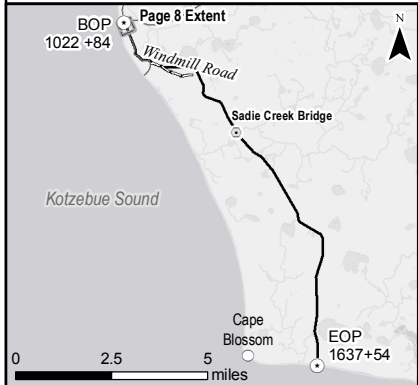
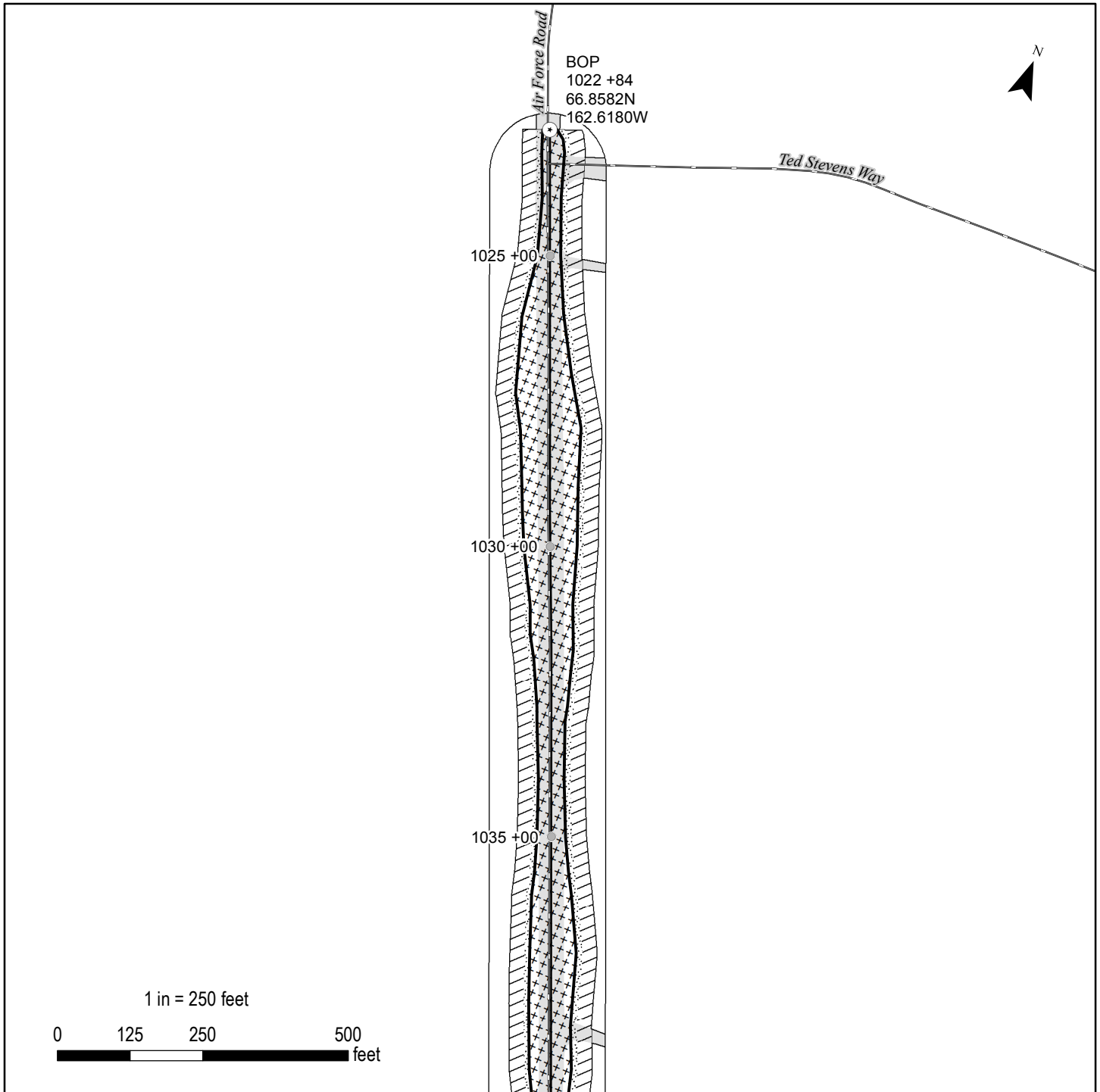

<ul style="list-style-type: none"> <li>⊙ Project Location</li> <li>● Station</li> <li>— DOT &amp; PF Road</li> </ul>	<ul style="list-style-type: none"> <li>— Kotzebue Cape Blossom Road</li> <li>▭ Project Footprint</li> </ul>
<b>Impacts</b>	
<ul style="list-style-type: none"> <li>Wetland</li> <li>+++ Fill</li> <li>⊘ Temporary Work Zone</li> <li>/// Vegetative Buffer</li> <li>□ No impact</li> </ul>	<ul style="list-style-type: none"> <li>Upland/Disturbed</li> <li>+++ Fill</li> <li>⊘ Temporary Work Zone</li> <li>/// Vegetative Buffer</li> <li>□ No impact</li> </ul>

<b>Plan View</b>	
<b>Applicant:</b> STATE OF ALASKA Department of Transportation and Public Facilities 2301 Peger Rd. Fairbanks, AK 99709	
Kotzebue to Cape Blossom Road Construction Project	
<b>File No.:</b> POA-2012-272	
<b>Waterway:</b> Kotzebue Sound	
<b>Proposed Activity:</b> Wetland fill for roadway	
<b>Date:</b> June 2017	Sheet 8 of 43



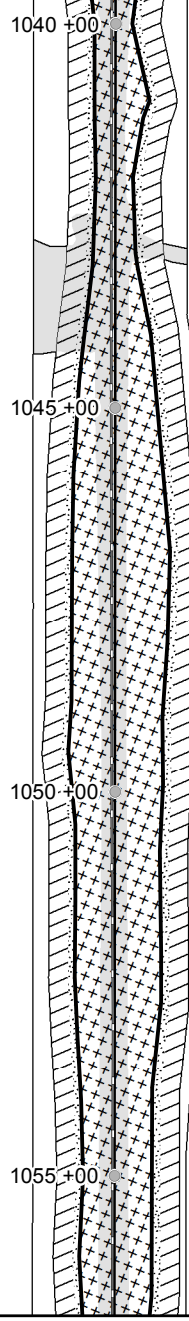

1 in = 250 feet

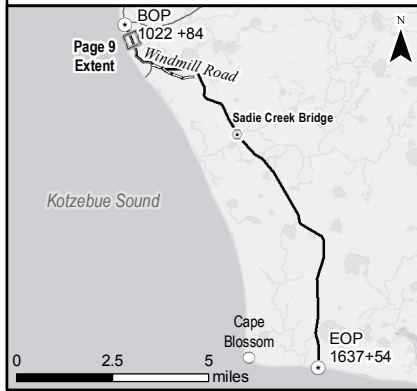
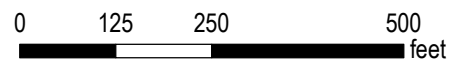

- Station
  - DOT & PF Road
  - Kotzebue Cape Blossom Road
  - ▭ Project Footprint
- Impacts**
- Wetland**
- +++ Fill
  - ▨ Temporary Work Zone
  - /// Vegetative Buffer
  - No impact
- Upland/Disturbed**
- +++ Fill
  - ▨ Temporary Work Zone
  - /// Vegetative Buffer
  - No impact

**Plan View**

**Applicant:** STATE OF ALASKA  
Department of Transportation and Public Facilities  
2301 Peger Rd. Fairbanks, AK 99709

Kotzebue to Cape Blossom  
Road Construction Project

**File No.:** POA-2012-272

**Waterway:** Kotzebue Sound

**Proposed Activity:** Wetland fill for roadway

**Date:** June 2017

Sheet 9 of 43

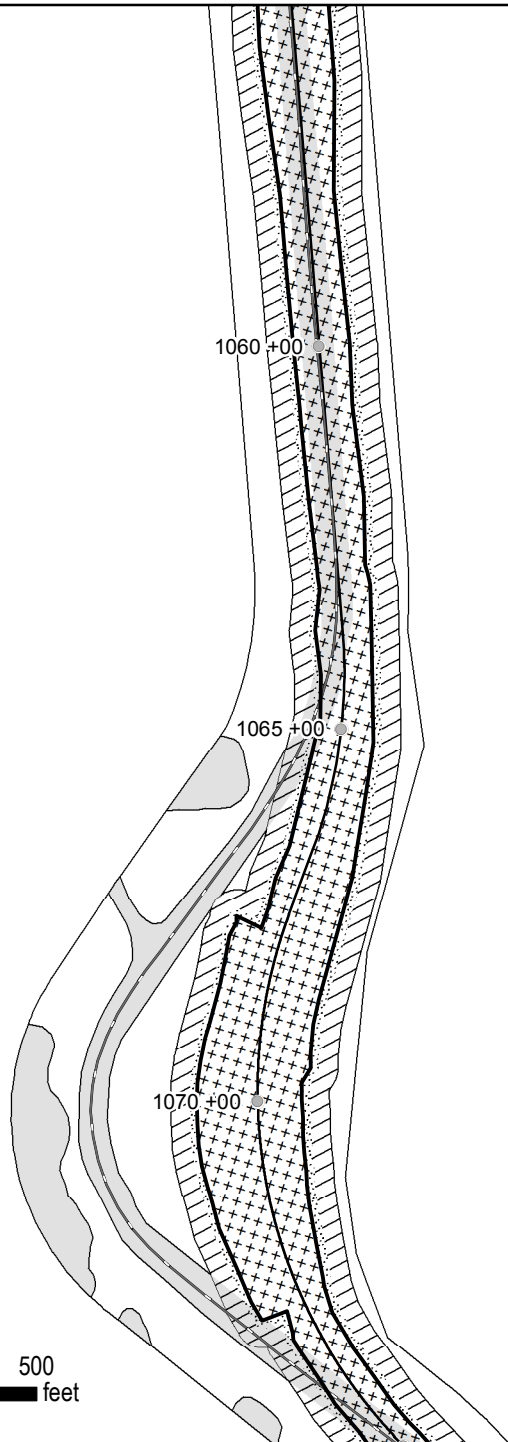

1 in = 250 feet

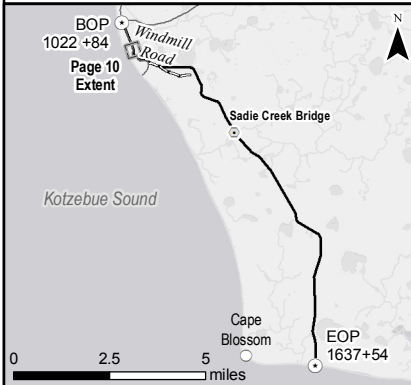
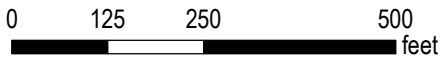

- Station
  - DOT & PF Road
  - Kotzebue Cape Blossom Road
  - ▭ Project Footprint
- Impacts**
- |                       |                         |
|-----------------------|-------------------------|
| <b>Wetland</b>        | <b>Upland/Disturbed</b> |
| +++ Fill              | +++ Fill                |
| ▨ Temporary Work Zone | ▨ Temporary Work Zone   |
| /// Vegetative Buffer | /// Vegetative Buffer   |
| □ No impact           | □ No impact             |

**Plan View**

**Applicant:** STATE OF ALASKA  
Department of Transportation and Public Facilities  
2301 Peger Rd. Fairbanks, AK 99709

Kotzebue to Cape Blossom  
Road Construction Project

**File No.:** POA-2012-272

**Waterway:** Kotzebue Sound

**Proposed Activity:** Wetland fill for roadway

**Date:** June 2017

Sheet 10 of 43

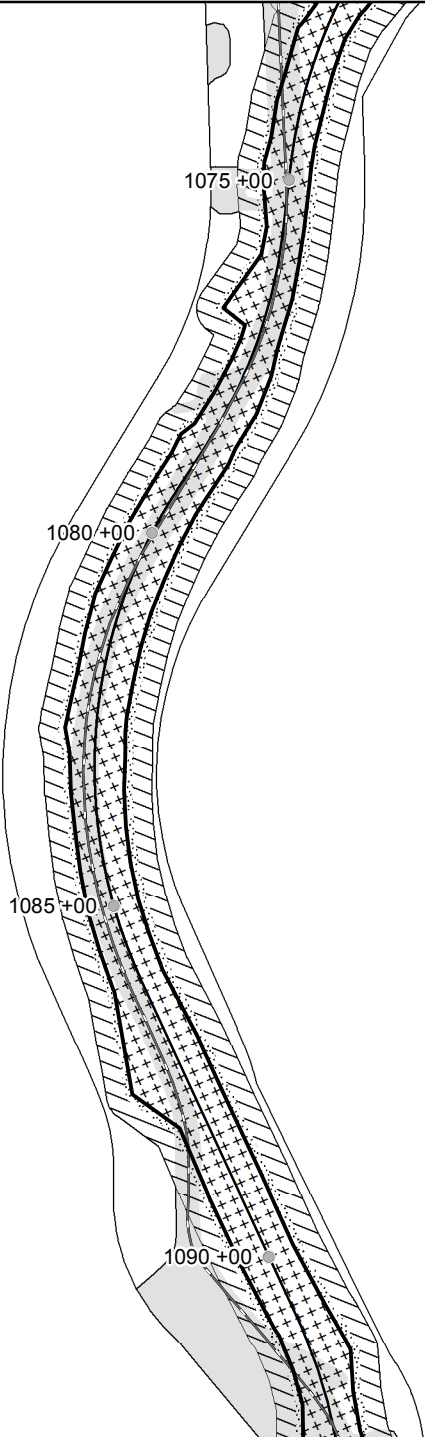

1 in = 250 feet

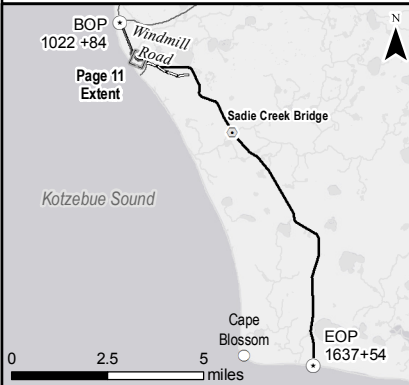
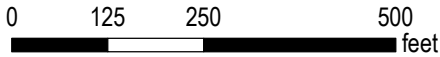

- Station
  - DOT & PF Road
  - Kotzebue Cape Blossom Road
  - ▭ Project Footprint
- Impacts**
- Wetland
  - +++ Fill
  - ▨ Temporary Work Zone
  - /// Vegetative Buffer
  - No impact
- Upland/Disturbed
  - +++ Fill
  - ▨ Temporary Work Zone
  - /// Vegetative Buffer
  - No impact

**Plan View**

**Applicant:** STATE OF ALASKA  
Department of Transportation and Public Facilities  
2301 Peger Rd. Fairbanks, AK 99709

Kotzebue to Cape Blossom  
Road Construction Project

**File No.:** POA-2012-272

**Waterway:** Kotzebue Sound

**Proposed Activity:** Wetland fill for roadway

**Date:** June 2017

Sheet 11 of 43

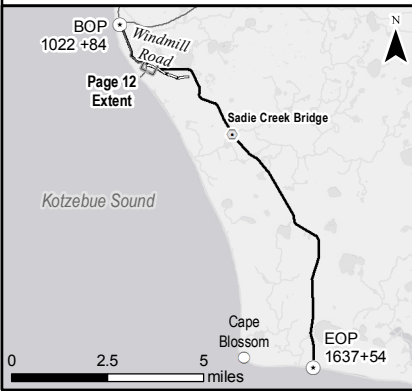
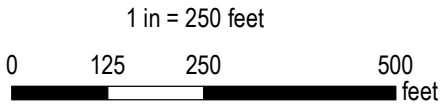
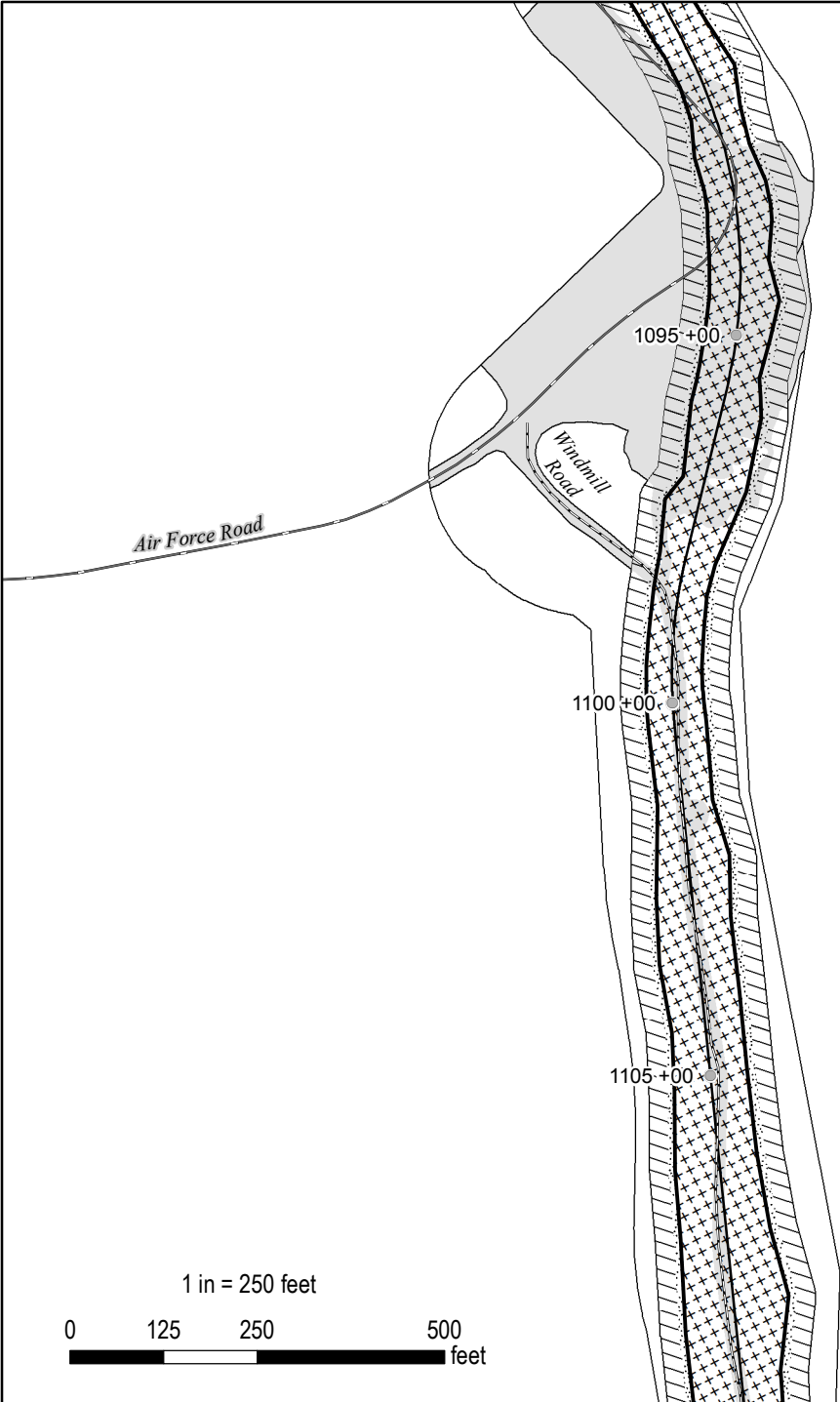

- Station
  - Windmill Road
  - DOT & PF Road
  - Kotzebue Cape Blossom Road
  - ▭ Project Footprint
- Impacts**
- Wetland**
- +++ Fill
  - ▨ Temporary Work Zone
  - /// Vegetative Buffer
  - No impact
- Upland/Disturbed**
- +++ Fill
  - ▨ Temporary Work Zone
  - /// Vegetative Buffer
  - No impact

**Plan View**

**Applicant:** STATE OF ALASKA  
Department of Transportation and Public Facilities  
2301 Peger Rd. Fairbanks, AK 99709

Kotzebue to Cape Blossom  
Road Construction Project

**File No.:** POA-2012-272

**Waterway:** Kotzebue Sound

**Proposed Activity:** Wetland fill for roadway

**Date:** June 2017

Sheet 12 of 43

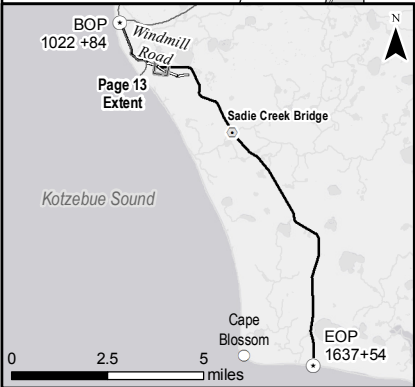
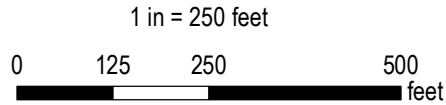
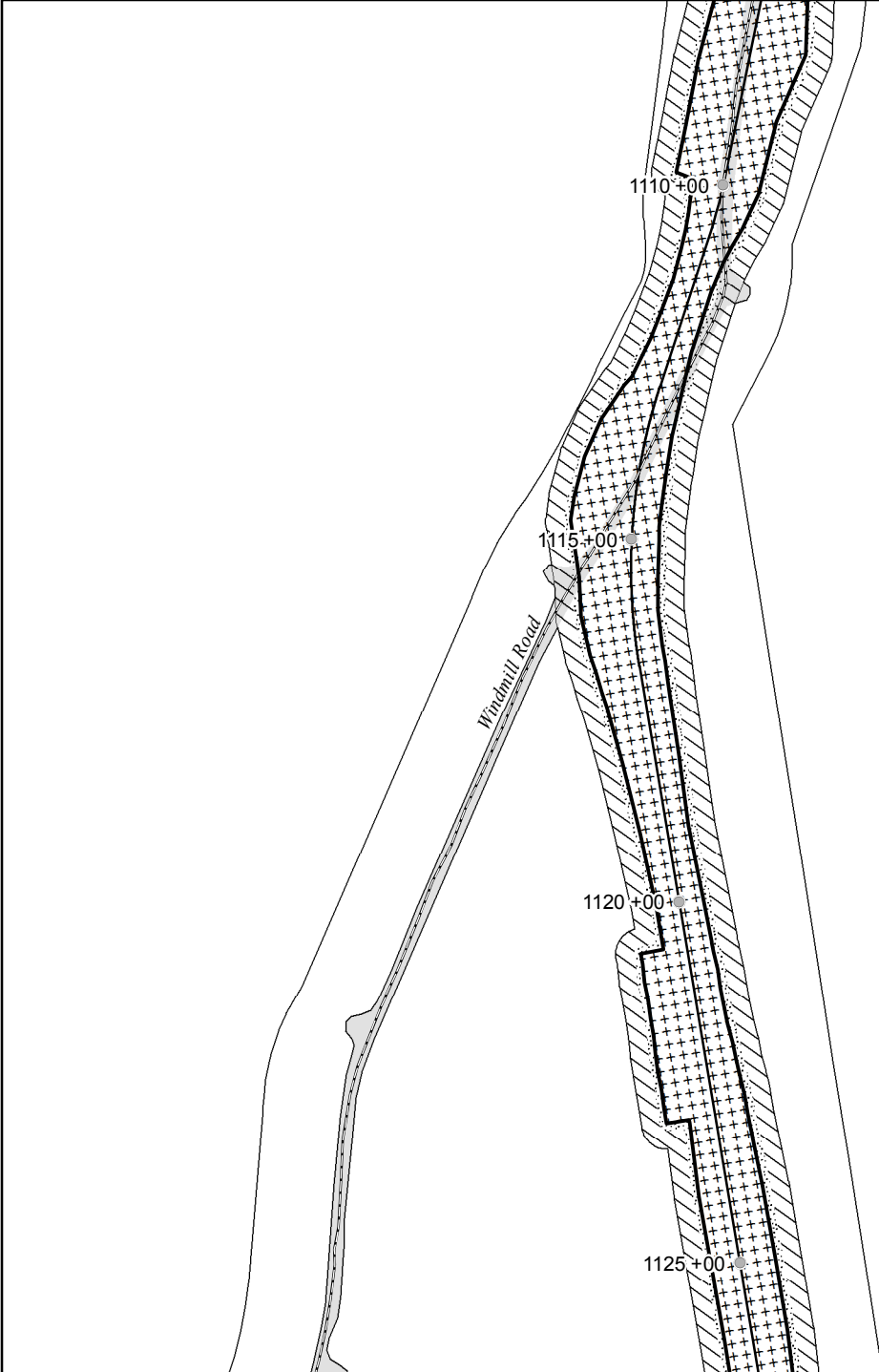

● Station	— Kotzebue Cape Blossom Road
— Windmill Road	▭ Project Footprint
<b>Impacts</b>	
<b>Wetland</b>	<b>Upland/Disturbed</b>
▨ Fill	▨ Fill
▤ Temporary Work Zone	▤ Temporary Work Zone
▧ Vegetative Buffer	▧ Vegetative Buffer
□ No impact	□ No impact

**Plan View**

<b>Applicant:</b>	STATE OF ALASKA Department of Transportation and Public Facilities 2301 Peger Rd. Fairbanks, AK 99709
<b>File No.:</b>	POA-2012-272
<b>Waterway:</b>	Kotzebue Sound
<b>Proposed Activity:</b>	Wetland fill for roadway
<b>Date:</b>	June 2017
Sheet 13 of 43	

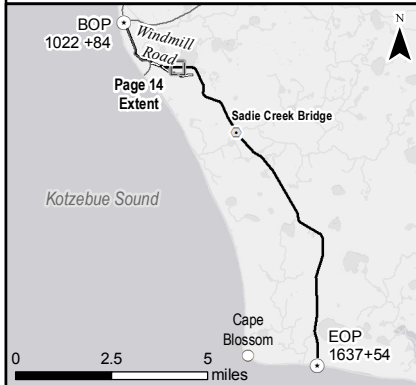
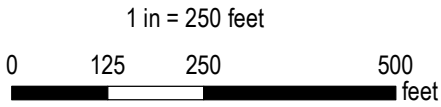
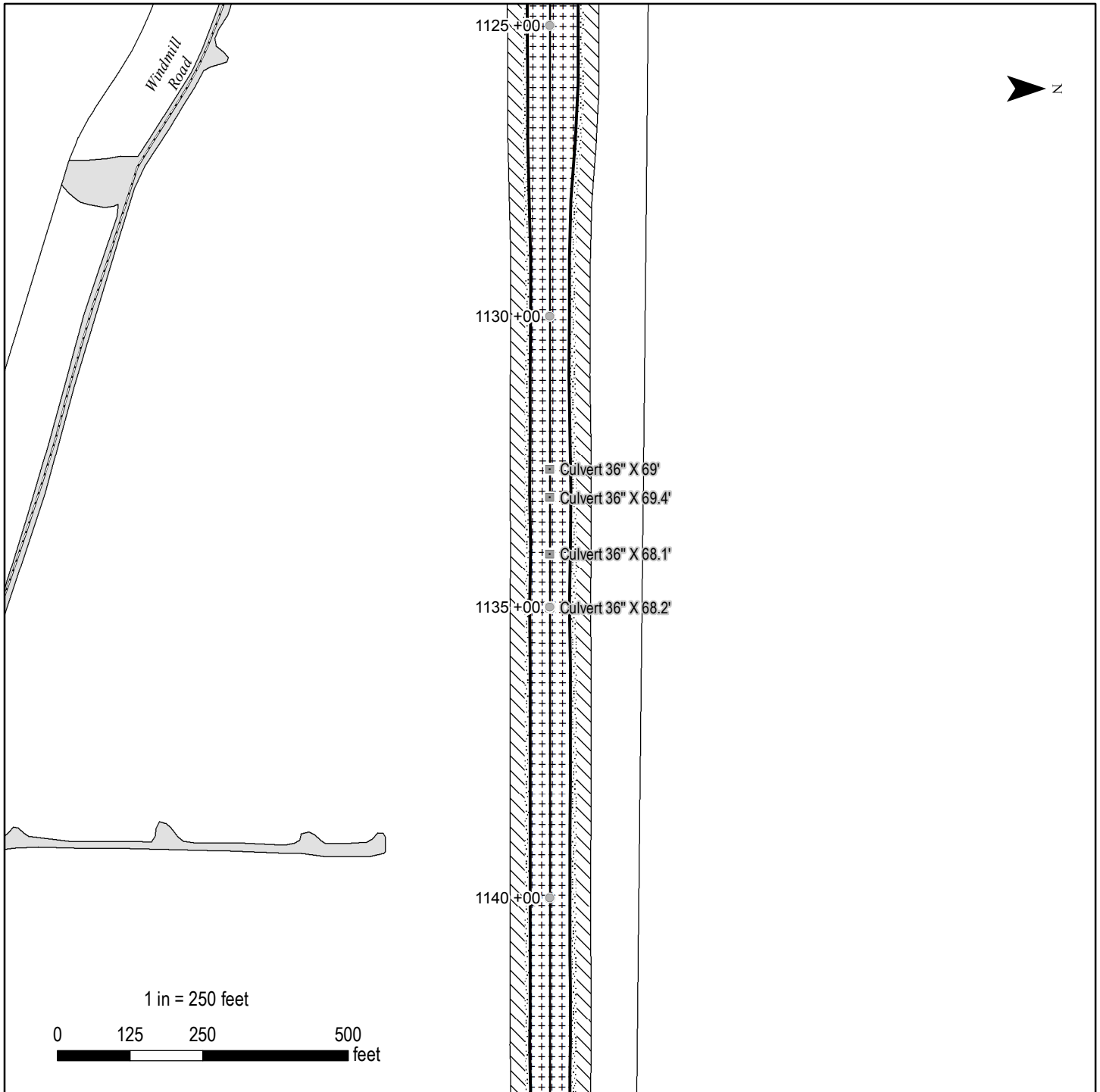

● Station	— Kotzebue Cape Blossom Road
■ Culvert	▭ Project Footprint
— Windmill Road	
<b>Impacts</b>	
<b>Wetland</b>	
+++ Fill	Upland/Disturbed
Temporary Work Zone	□ No impact
Vegetative Buffer	
□ No impact	

<b>Plan View</b>	
<b>Applicant:</b> STATE OF ALASKA Department of Transportation and Public Facilities 2301 Peger Rd. Fairbanks, AK 99709	
Kotzebue to Cape Blossom Road Construction Project	
<b>File No.:</b> POA-2012-272	
<b>Waterway:</b> Kotzebue Sound	
<b>Proposed Activity:</b> Wetland fill for roadway	
<b>Date:</b> June 2017	Sheet 14 of 43

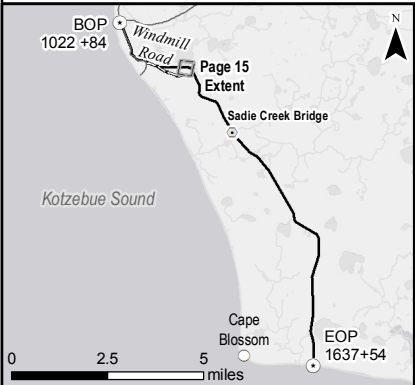
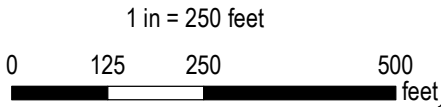
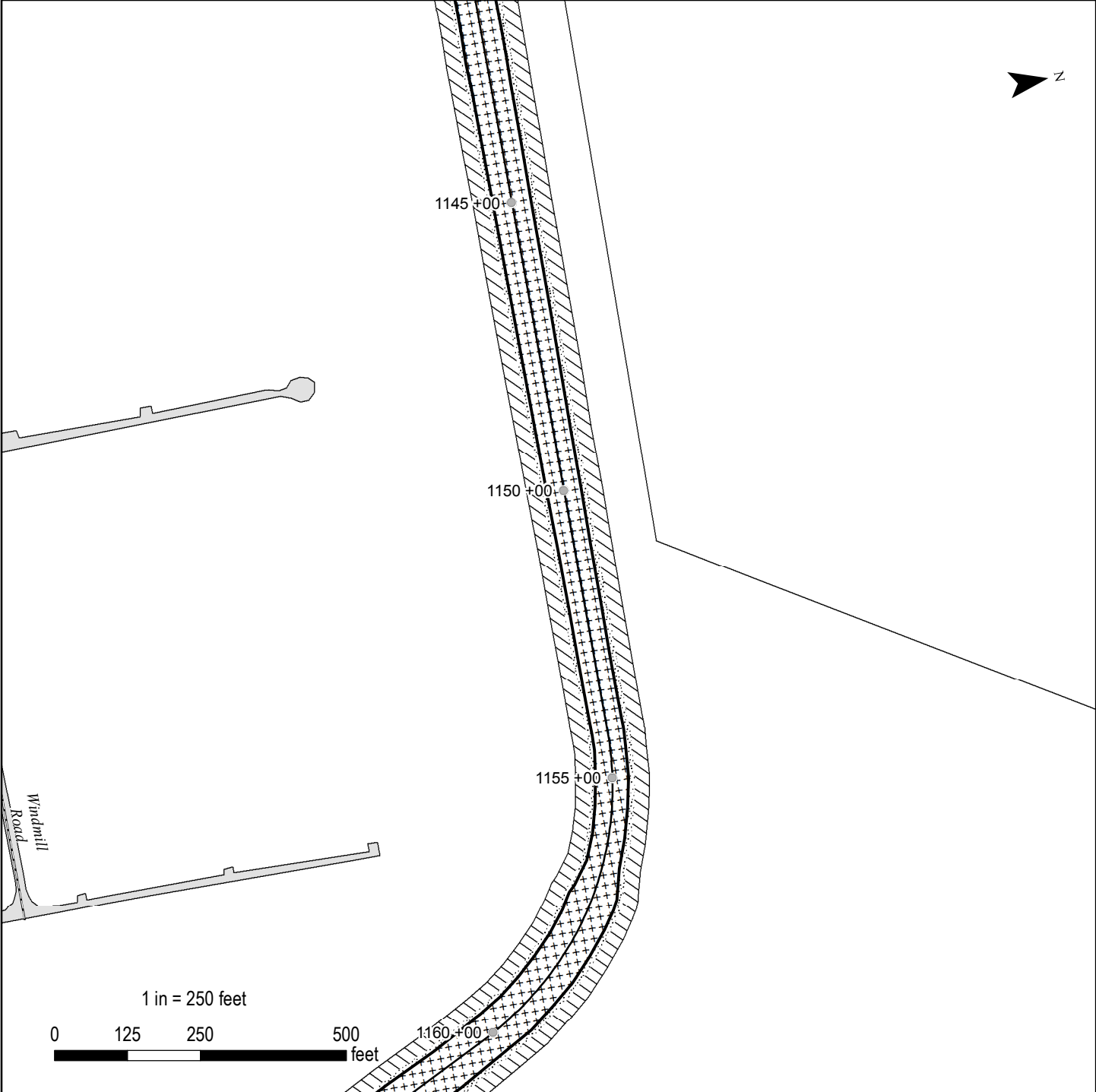

● Station	— Kotzebue Cape Blossom Road
— Windmill Road	▭ Project Footprint
<b>Impacts</b>	
<b>Wetland</b>	
+++ Fill	Upland/Disturbed
⊘ Temporary Work Zone	□ No impact
/// Vegetative Buffer	
□ No impact	

**Plan View**

<b>Applicant:</b> STATE OF ALASKA Department of Transportation and Public Facilities 2301 Peger Rd. Fairbanks, AK 99709  Kotzebue to Cape Blossom Road Construction Project	
<b>File No.:</b> POA-2012-272	
<b>Waterway:</b> Kotzebue Sound	
<b>Proposed Activity:</b> Wetland fill for roadway	
<b>Date:</b> June 2017	Sheet 15 of 43

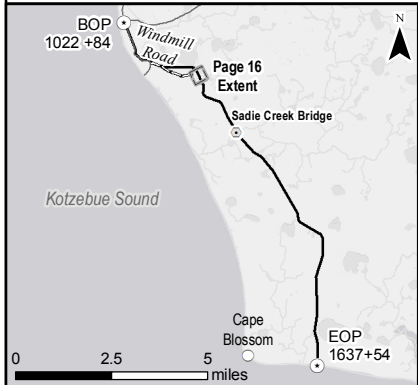
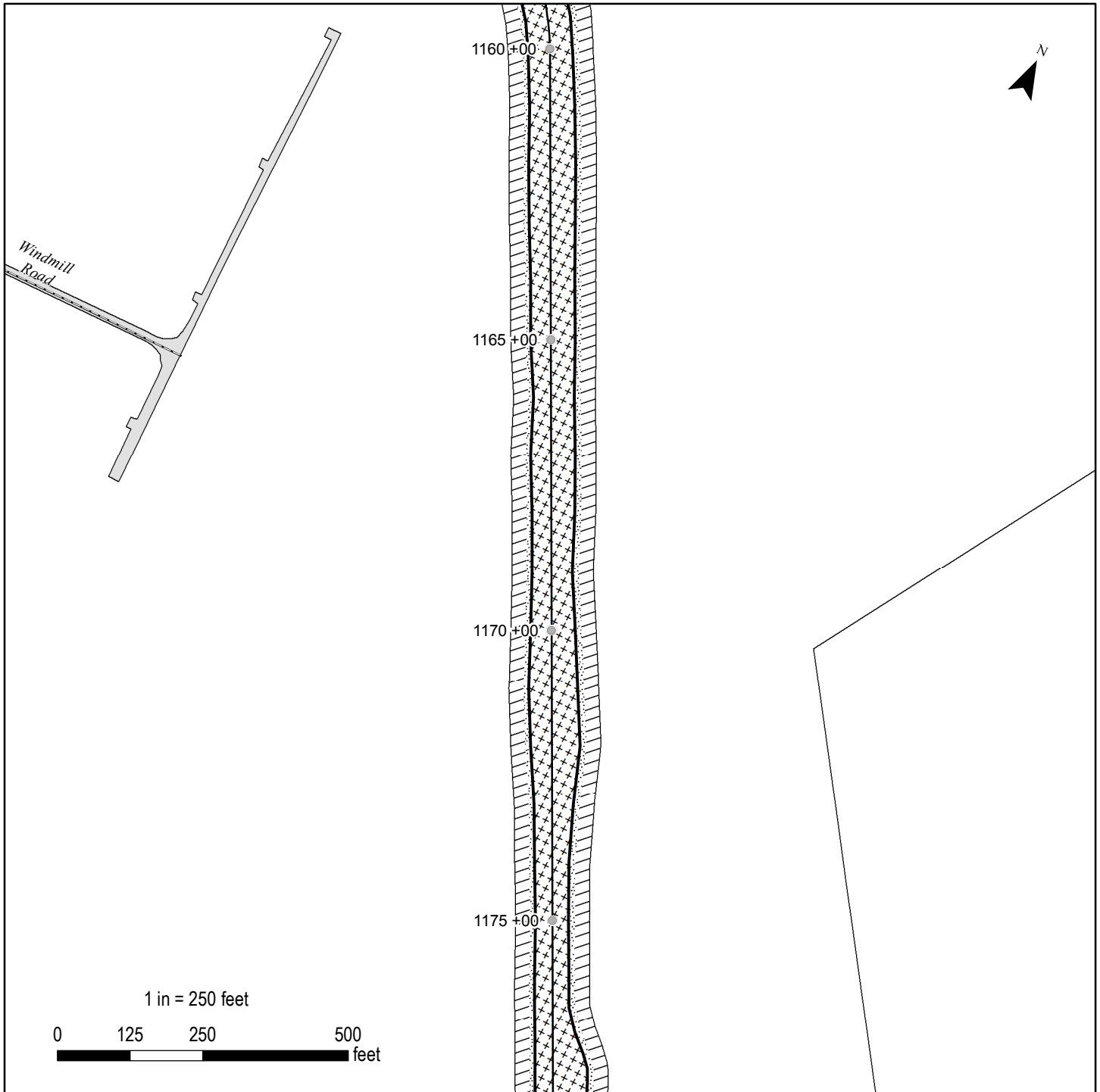

● Station  
— Windmill Road  
— Kotzebue Cape Blossom Road  
▭ Project Footprint

**Impacts**

**Wetland**  
 +++ Fill  
 Temporary Work Zone  
 // Vegetative Buffer  
 □ No impact

**Upland/Disturbed**  
 □ No impact

<b>Plan View</b>	
<b>Applicant:</b> STATE OF ALASKA Department of Transportation and Public Facilities 2301 Peger Rd. Fairbanks, AK 99709	
Kotzebue to Cape Blossom Road Construction Project	
<b>File No.:</b> POA-2012-272	
<b>Waterway:</b> Kotzebue Sound	
<b>Proposed Activity:</b> Wetland fill for roadway	
<b>Date:</b> June 2017	Sheet 16 of 43





1180 +00

1185 +00

Culvert 36" X 88.6'

1190 +00

1195 +00

1 in = 250 feet

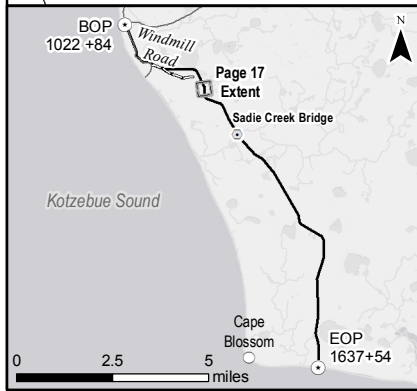
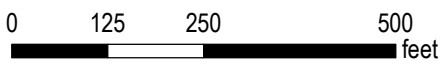

- Station
- Culvert
- Kotzebue Cape Blossom Road
- ▭ Project Footprint

**Impacts**

**Wetland**

- +++ Fill
- ⊞ Temporary Work Zone
- /// Vegetative Buffer
- No impact

**Plan View**

**Applicant:** STATE OF ALASKA  
 Department of Transportation and Public Facilities  
 2301 Peger Rd. Fairbanks, AK 99709

Kotzebue to Cape Blossom  
 Road Construction Project

**File No.:** POA-2012-272

**Waterway:** Kotzebue Sound

**Proposed Activity:** Wetland fill for roadway

**Date:** June 2017

Sheet 17 of 43

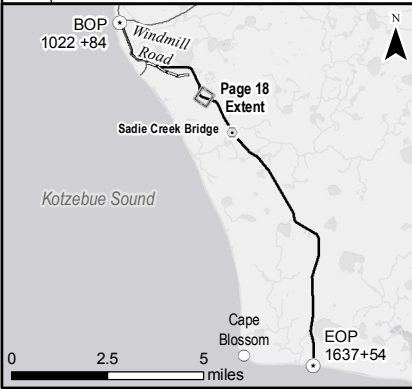
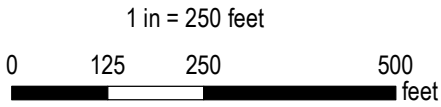
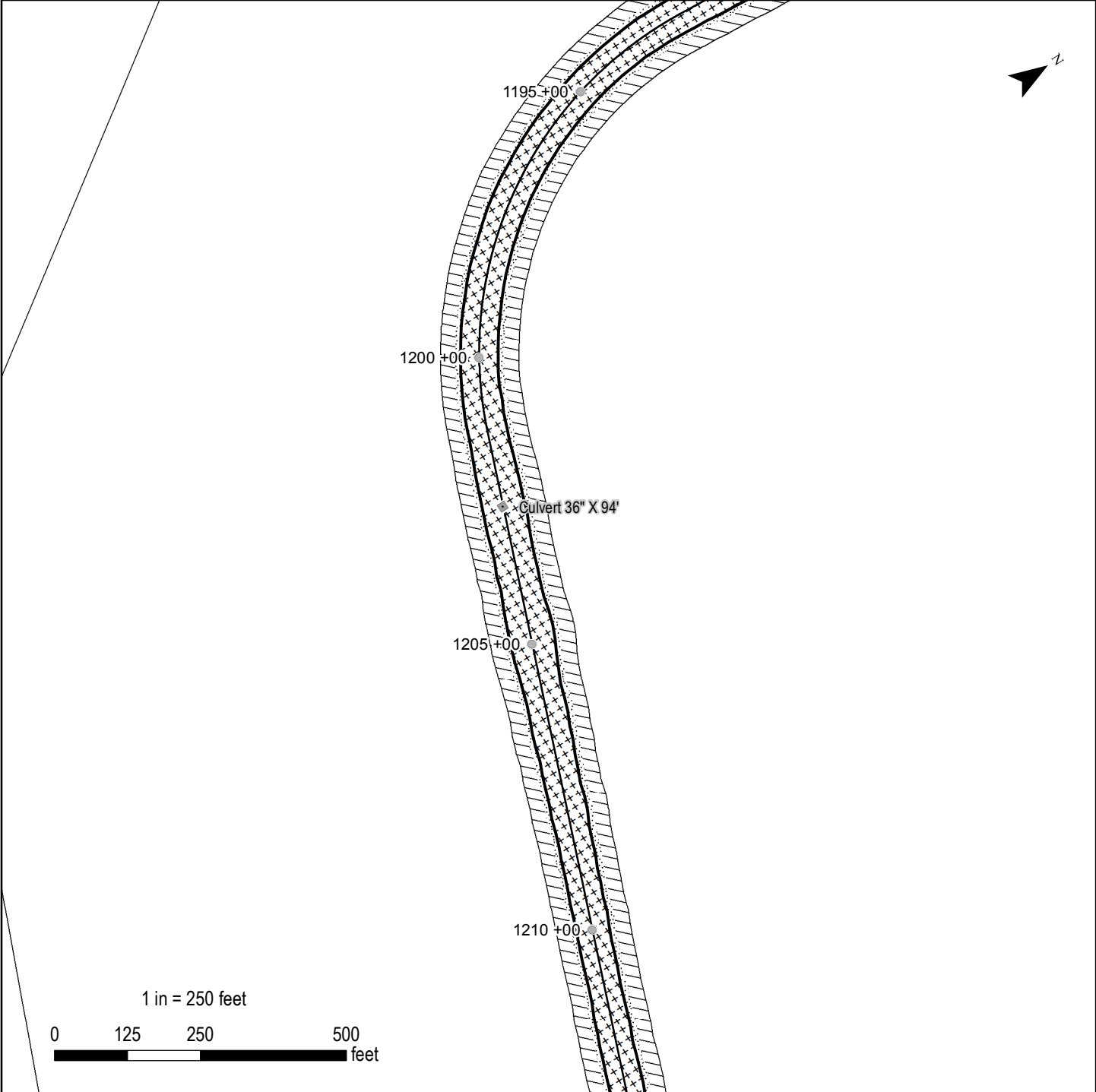

● Station	— Kotzebue Cape Blossom Road
■ Culvert	▭ Project Footprint

**Impacts**

**Wetland**

- +++ Fill
- ⊞ Temporary Work Zone
- /// Vegetative Buffer
- No impact

<b>Plan View</b>	
<b>Applicant:</b> STATE OF ALASKA Department of Transportation and Public Facilities 2301 Peger Rd. Fairbanks, AK 99709	
Kotzebue to Cape Blossom Road Construction Project	
<b>File No.:</b> POA-2012-272	
<b>Waterway:</b> Kotzebue Sound	
<b>Proposed Activity:</b> Wetland fill for roadway	
<b>Date:</b> June 2017	Sheet 18 of 43

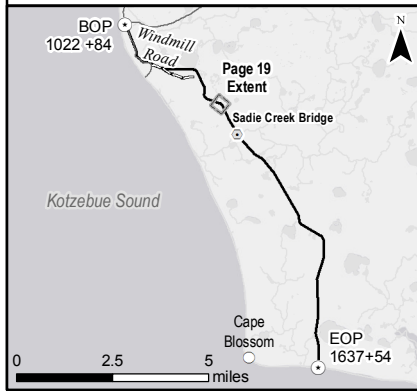
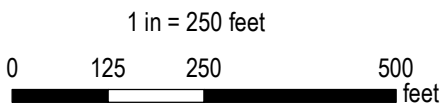
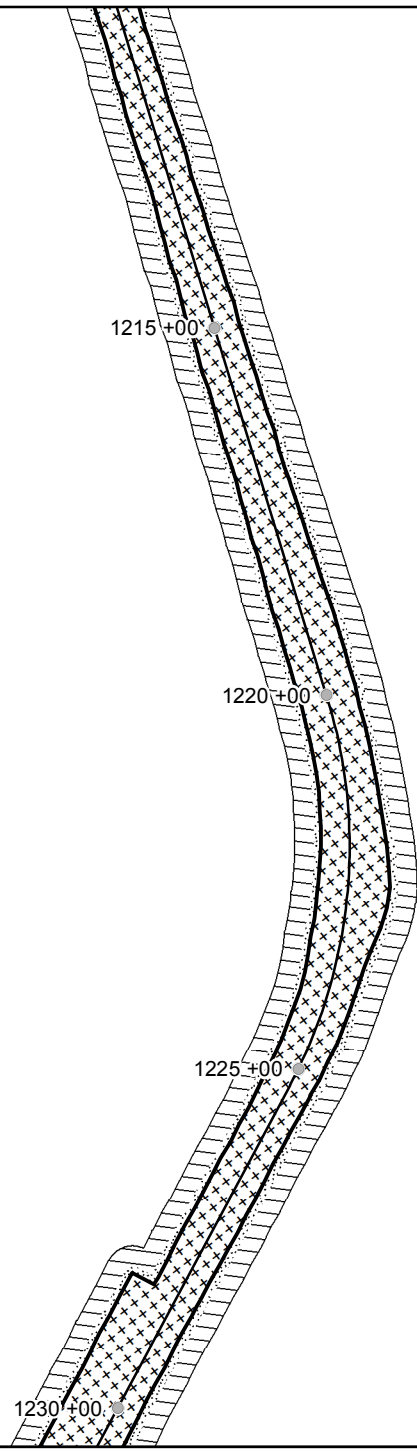

● Station      — Kotzebue Cape Blossom Road  
 □ Project Footprint

**Impacts**

**Wetland**

+++ Fill  
 Temporary Work Zone  
 // Vegetative Buffer  
 □ No impact

**Plan View**

<b>Applicant:</b> STATE OF ALASKA Department of Transportation and Public Facilities 2301 Peger Rd. Fairbanks, AK 99709	
Kotzebue to Cape Blossom Road Construction Project	
<b>File No.:</b> POA-2012-272	
<b>Waterway:</b> Kotzebue Sound	
<b>Proposed Activity:</b> Wetland fill for roadway	
<b>Date:</b> June 2017	Sheet 19 of 43



1230+00

1235+00

1240+00

1245+00

1 in = 250 feet

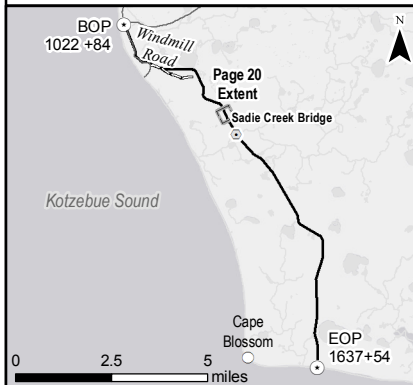
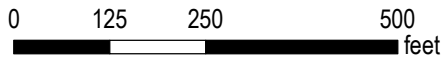

- Station
- Kotzebue Cape Blossom Road
- ▭ Project Footprint

**Impacts**

**Wetland**

- +++ Fill
- ⊞ Temporary Work Zone
- /// Vegetative Buffer
- No impact

**Plan View**

**Applicant:** STATE OF ALASKA  
 Department of Transportation and Public Facilities  
 2301 Peger Rd. Fairbanks, AK 99709

Kotzebue to Cape Blossom  
 Road Construction Project

**File No.:** POA-2012-272

**Waterway:** Kotzebue Sound

**Proposed Activity:** Wetland fill for roadway

**Date:** June 2017

Sheet 20 of 43



1250+00  
1255+00  
1260+00

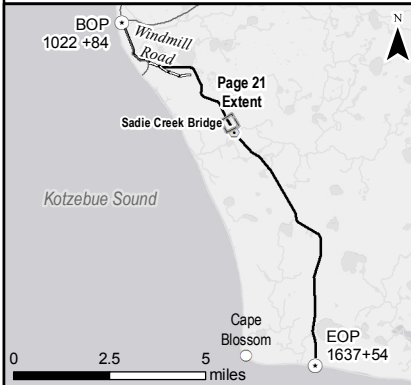
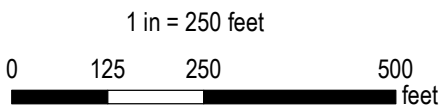

- Station
- Kotzebue Cape Blossom Road
- ▭ Project Footprint

**Impacts**

**Wetland**

- +++ Fill
- ⊞ Temporary Work Zone
- /// Vegetative Buffer
- No impact

**Plan View**

**Applicant:** STATE OF ALASKA  
 Department of Transportation and Public Facilities  
 2301 Peger Rd. Fairbanks, AK 99709

Kotzebue to Cape Blossom  
 Road Construction Project

**File No.:** POA-2012-272

**Waterway:** Kotzebue Sound

**Proposed Activity:** Wetland fill for roadway

**Date:** June 2017

Sheet 21 of 43

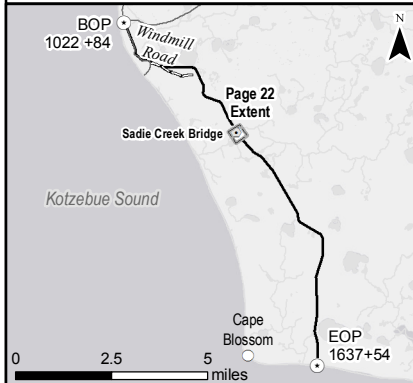
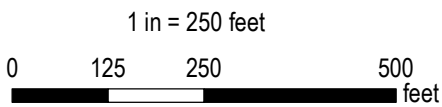
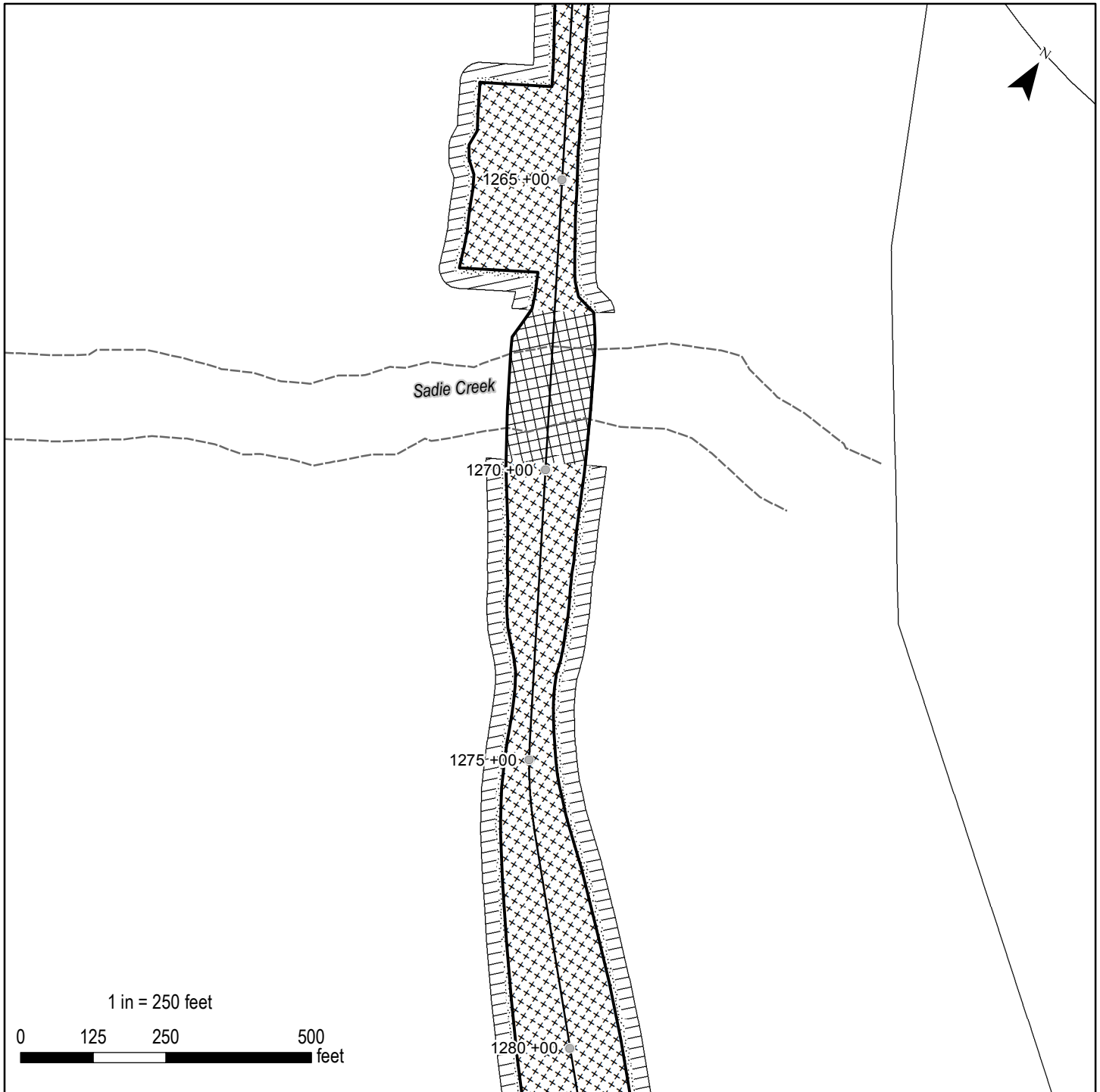

- Station
  - Ordinary High Water
  - Kotzebue Cape Blossom Road
  - ▭ Project Footprint
- Impacts**
- Wetland**
- +++ Fill
  - ▨ Temporary Work Zone
  - /// Vegetative Buffer
  - ×× Bridge Work Zone
  - No impact

<b>Plan View</b>	
<b>Applicant:</b> STATE OF ALASKA Department of Transportation and Public Facilities 2301 Peger Rd. Fairbanks, AK 99709	
Kotzebue to Cape Blossom Road Construction Project	
<b>File No.:</b> POA-2012-272	
<b>Waterway:</b> Kotzebue Sound	
<b>Proposed Activity:</b> Wetland fill for roadway	
<b>Date:</b> June 2017	Sheet 22 of 43

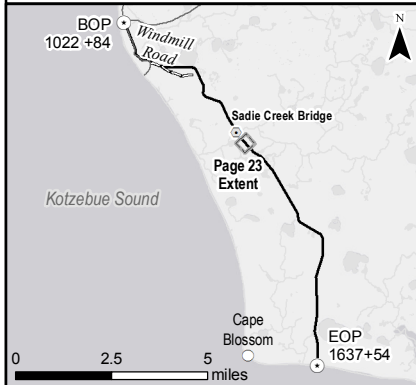
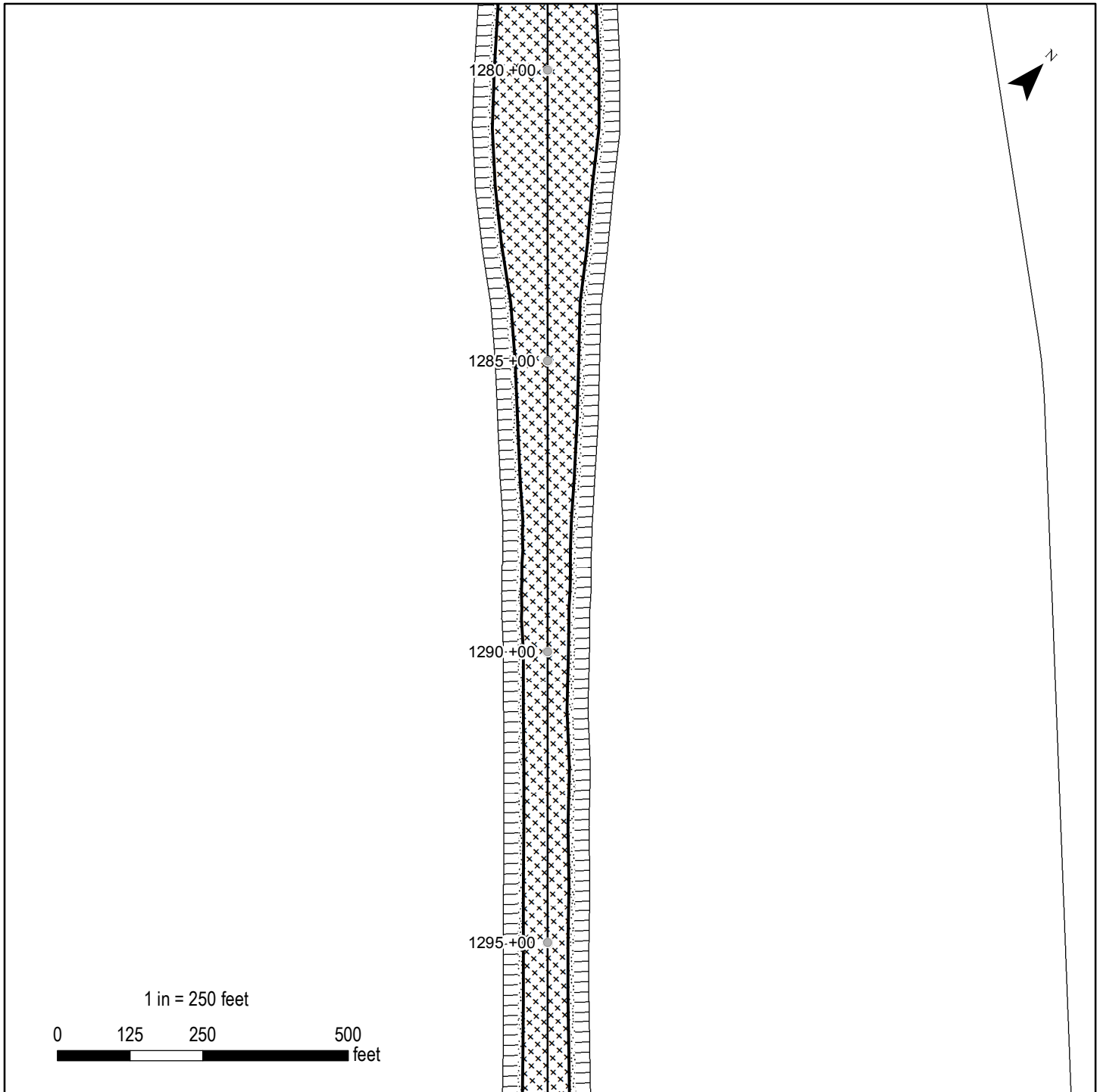

- Station
- Kotzebue Cape Blossom Road
- ▭ Project Footprint

**Impacts**

**Wetland**

- +++ Fill
- ⊞ Temporary Work Zone
- /// Vegetative Buffer
- No impact

<b>Plan View</b>	
<b>Applicant:</b> STATE OF ALASKA Department of Transportation and Public Facilities 2301 Peger Rd. Fairbanks, AK 99709	
Kotzebue to Cape Blossom Road Construction Project	
<b>File No.:</b> POA-2012-272	
<b>Waterway:</b> Kotzebue Sound	
<b>Proposed Activity:</b> Wetland fill for roadway	
<b>Date:</b> June 2017	Sheet 23 of 43

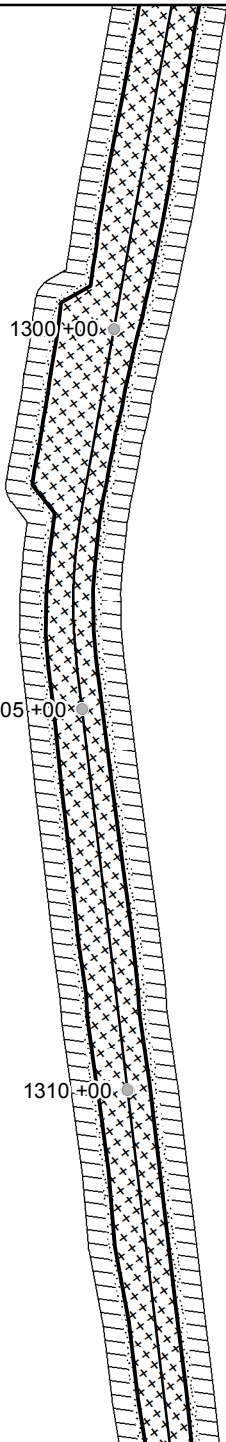

1 in = 250 feet

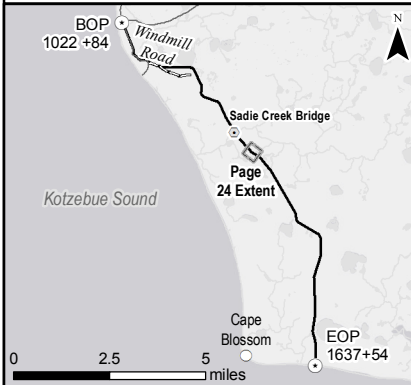
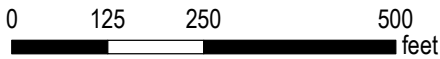

- Station
- Kotzebue Cape Blossom Road
- ▭ Project Footprint

**Impacts**

**Wetland**

- +++ Fill
- ⊞ Temporary Work Zone
- /// Vegetative Buffer
- No impact

**Plan View**

**Applicant:** STATE OF ALASKA  
 Department of Transportation and Public Facilities  
 2301 Peger Rd. Fairbanks, AK 99709

Kotzebue to Cape Blossom  
 Road Construction Project

**File No.:** POA-2012-272

**Waterway:** Kotzebue Sound

**Proposed Activity:** Wetland fill for roadway

**Date:** June 2017

Sheet 24 of 43



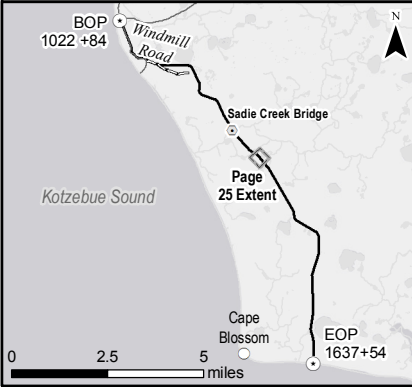
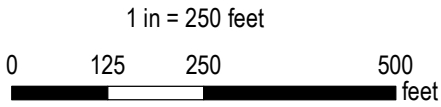
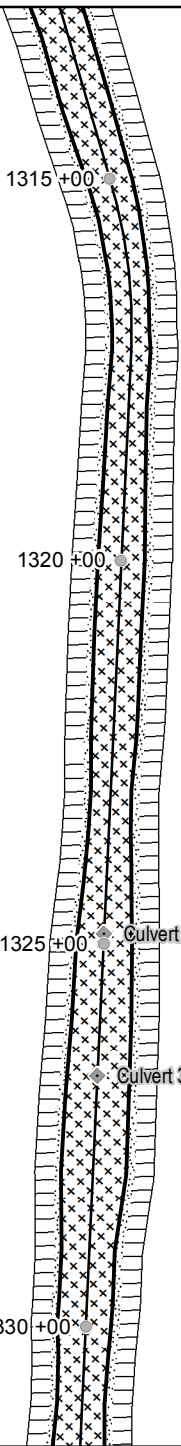

● Station	— Kotzebue Cape Blossom Road
■ Culvert	▭ Project Footprint
<b>Impacts</b>	
<b>Wetland</b>	
+++ Fill	
⊞ Temporary Work Zone	
/// Vegetative Buffer	
□ No impact	

**Plan View**

**Applicant:** STATE OF ALASKA  
Department of Transportation and Public Facilities  
2301 Peger Rd. Fairbanks, AK 99709

Kotzebue to Cape Blossom  
Road Construction Project

**File No.:** POA-2012-272

**Waterway:** Kotzebue Sound

**Proposed Activity:** Wetland fill for roadway

**Date:** June 2017

Sheet 25 of 43

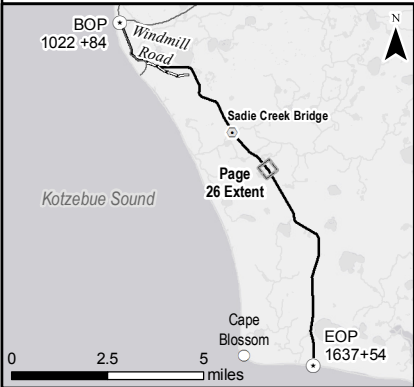
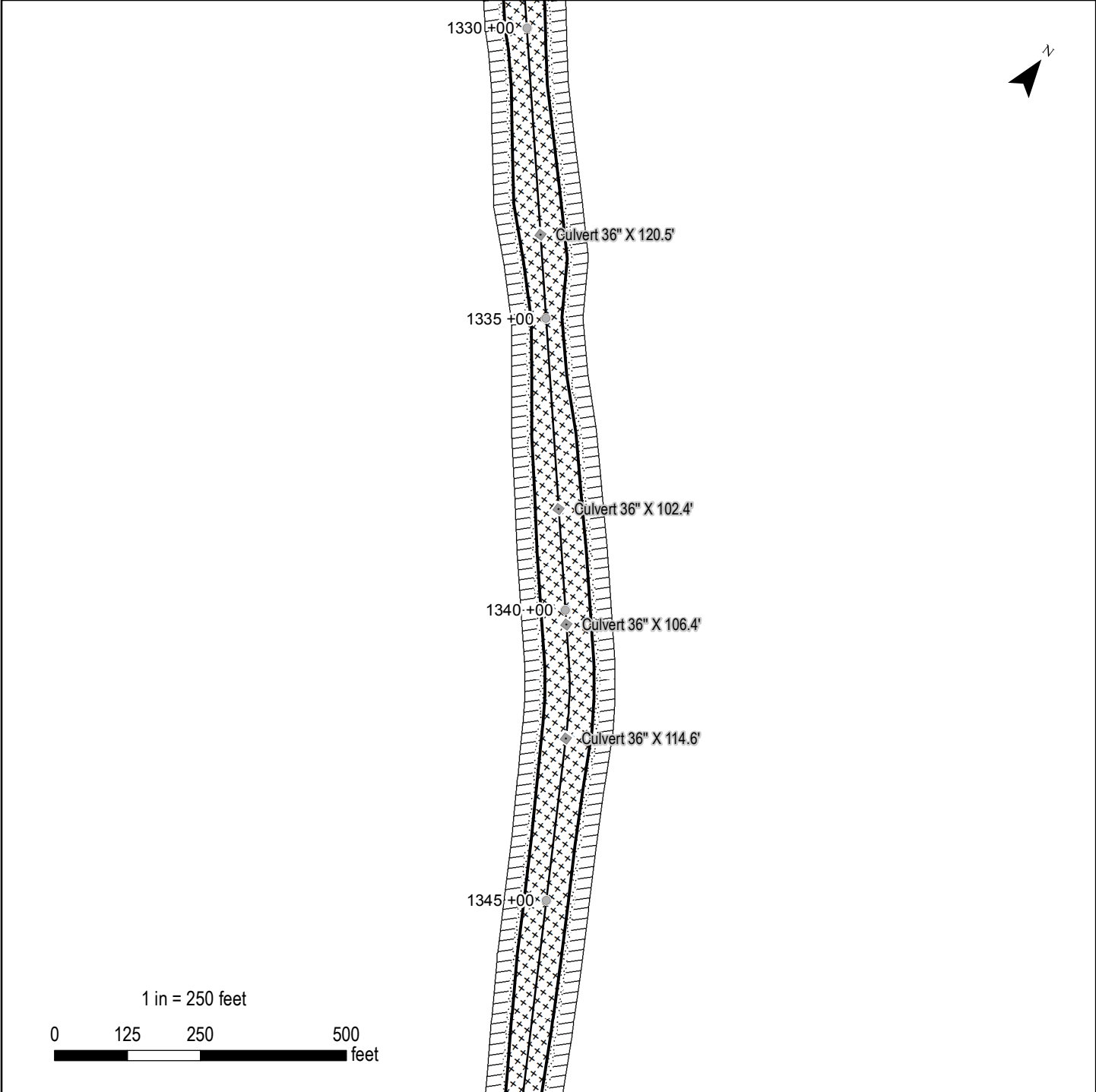

- Station
- Culvert
- Kotzebue Cape Blossom Road
- ▭ Project Footprint

**Impacts**

**Wetland**

- +++ Fill
- Temporary Work Zone
- Vegetative Buffer
- No impact

<b>Plan View</b>	
<b>Applicant:</b> STATE OF ALASKA Department of Transportation and Public Facilities 2301 Peger Rd. Fairbanks, AK 99709	
Kotzebue to Cape Blossom Road Construction Project	
<b>File No.:</b> POA-2012-272	
<b>Waterway:</b> Kotzebue Sound	
<b>Proposed Activity:</b> Wetland fill for roadway	
<b>Date:</b> June 2017	Sheet 26 of 43



1350 +00

1355 +00

1360 +00

1 in = 250 feet

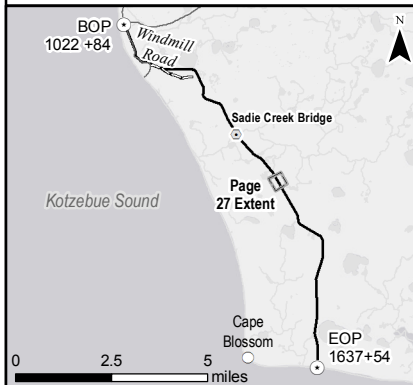
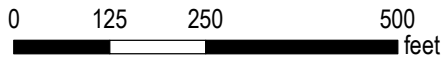

- Station
- Kotzebue Cape Blossom Road
- ▭ Project Footprint

**Impacts**

- Wetland**
- +++ Fill
- ⊞ Temporary Work Zone
- /// Vegetative Buffer
- No impact

- Upland/Disturbed**
- No impact

**Plan View**

**Applicant:** STATE OF ALASKA  
 Department of Transportation and Public Facilities  
 2301 Peger Rd. Fairbanks, AK 99709

Kotzebue to Cape Blossom  
 Road Construction Project

**File No.:** POA-2012-272

**Waterway:** Kotzebue Sound

**Proposed Activity:** Wetland fill for roadway

**Date:** June 2017

Sheet 27 of 43

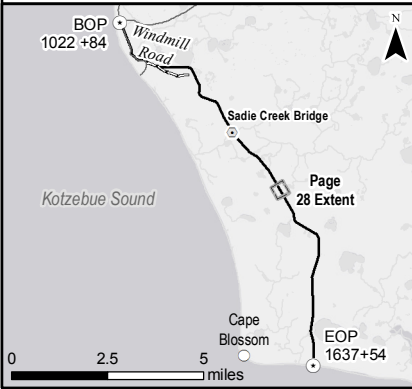
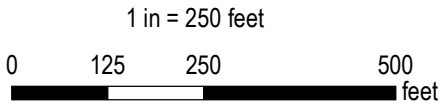
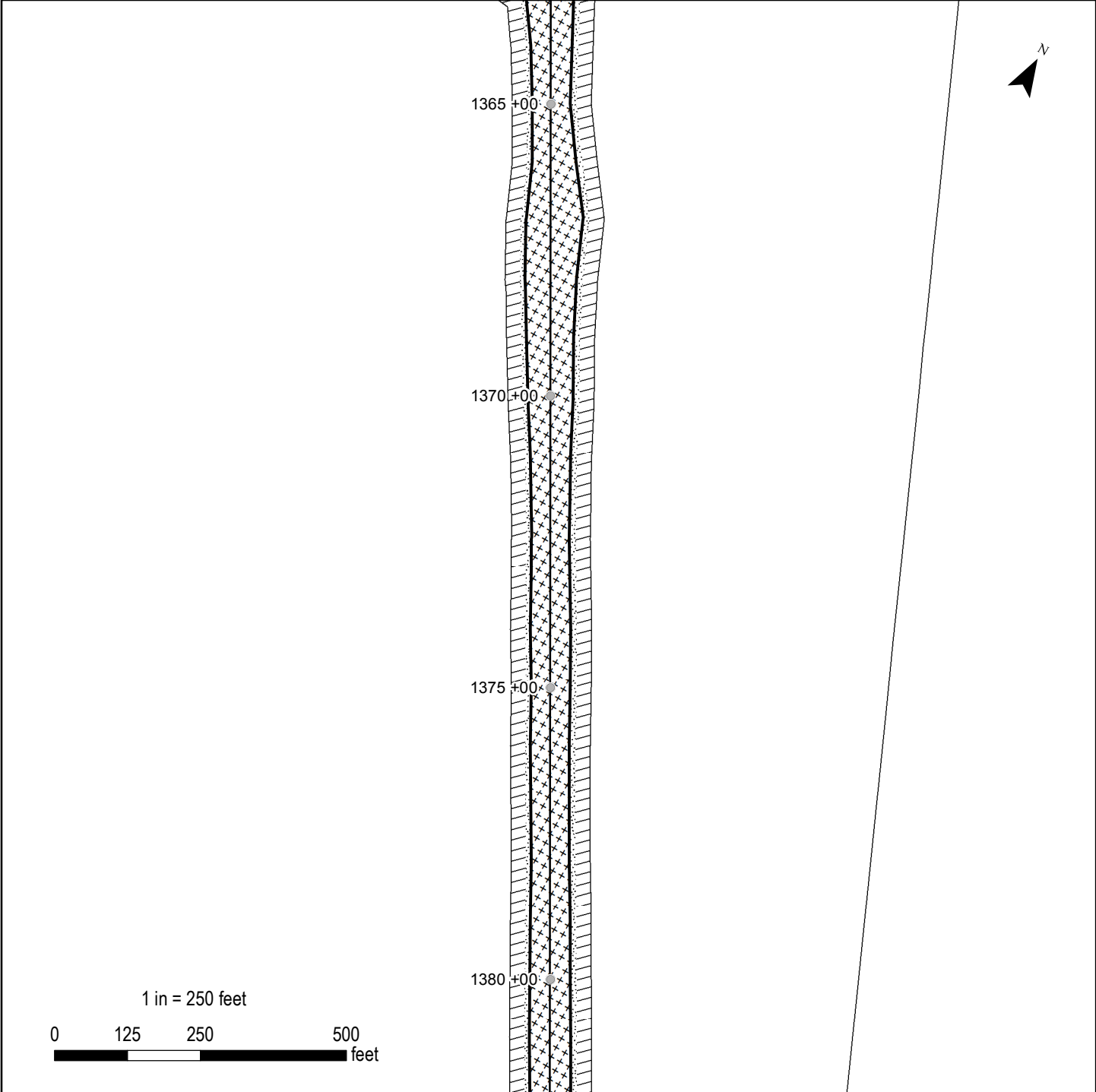

- Station
- Kotzebue Cape Blossom Road
- ▭ Project Footprint

**Impacts**

**Wetland**

- +++ Fill
- ⊞ Temporary Work Zone
- /// Vegetative Buffer
- No impact

<b>Plan View</b>	
<b>Applicant:</b> STATE OF ALASKA Department of Transportation and Public Facilities 2301 Peger Rd. Fairbanks, AK 99709	
Kotzebue to Cape Blossom Road Construction Project	
<b>File No.:</b> POA-2012-272	
<b>Waterway:</b> Kotzebue Sound	
<b>Proposed Activity:</b> Wetland fill for roadway	
<b>Date:</b> June 2017	Sheet 28 of 43



1385+00  
1390+00  
1395+00  
Culvert 36" X 97'

1 in = 250 feet

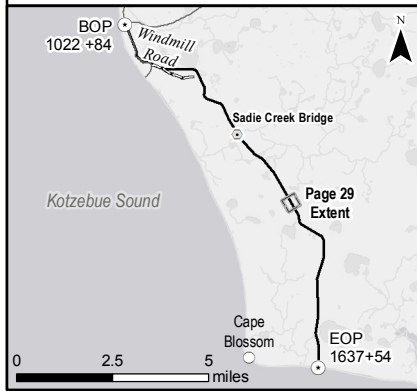
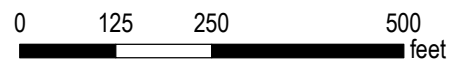

- Station
- Culvert
- Kotzebue Cape Blossom Road
- ▭ Project Footprint

**Impacts**

**Wetland**

- +++ Fill
- ⊞ Temporary Work Zone
- /// Vegetative Buffer
- No impact

**Plan View**

**Applicant:** STATE OF ALASKA  
 Department of Transportation and Public Facilities  
 2301 Peger Rd. Fairbanks, AK 99709

Kotzebue to Cape Blossom  
 Road Construction Project

**File No.:** POA-2012-272

**Waterway:** Kotzebue Sound

**Proposed Activity:** Wetland fill for roadway

**Date:** June 2017

Sheet 29 of 43

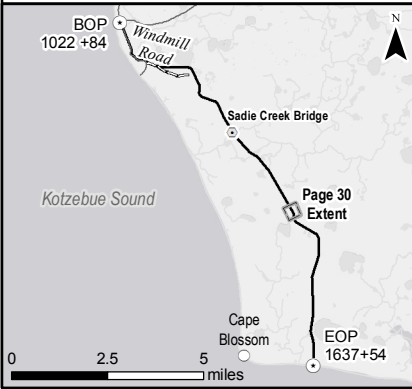
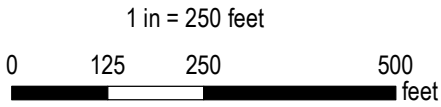
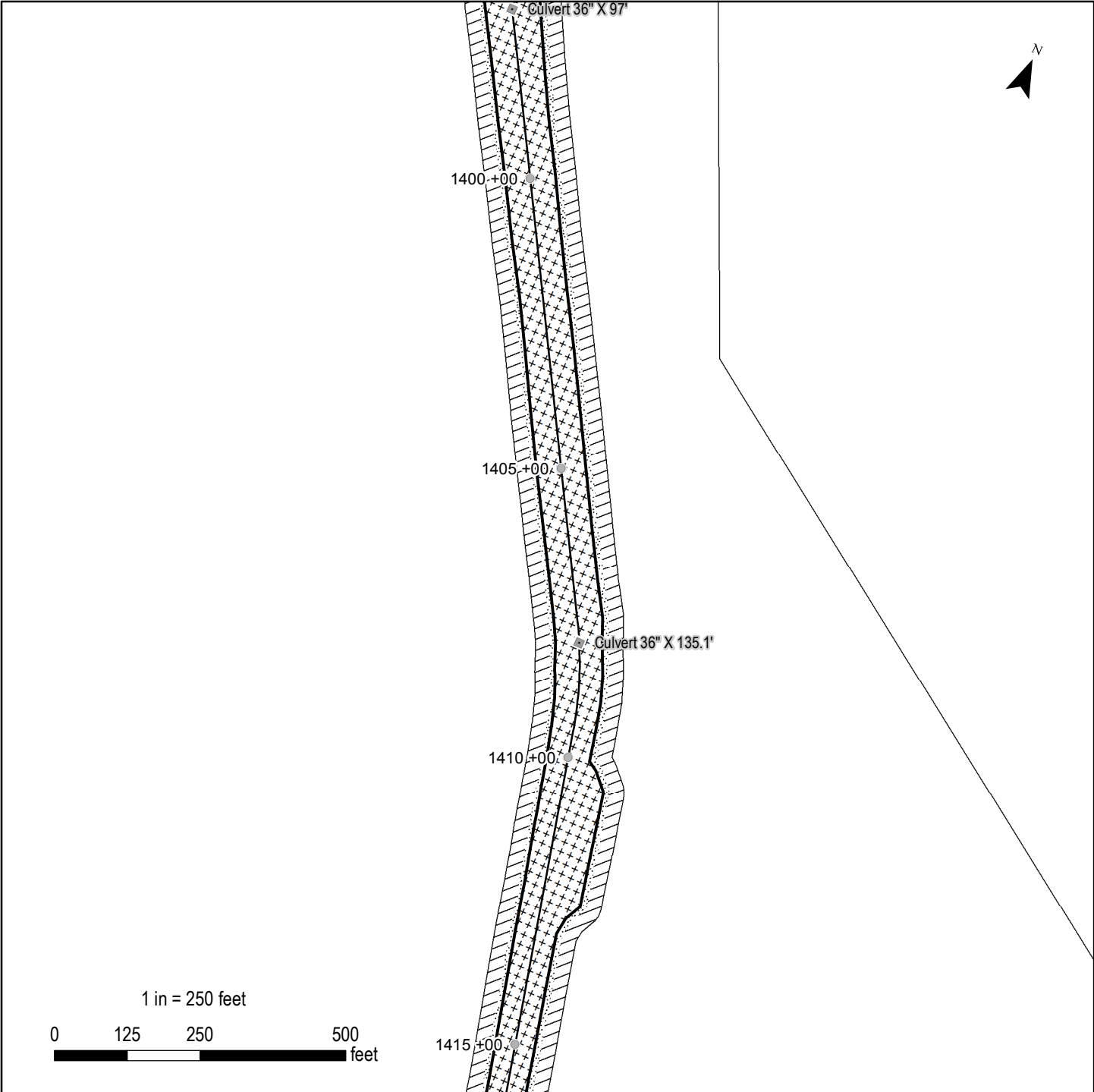

● Station	— Kotzebue Cape Blossom Road
■ Culvert	▭ Project Footprint

**Impacts**

**Wetland**

+++ Fill

⊘ Temporary Work Zone

/// Vegetative Buffer

□ No impact

<b>Plan View</b>	
<b>Applicant:</b> STATE OF ALASKA Department of Transportation and Public Facilities 2301 Peger Rd. Fairbanks, AK 99709	
Kotzebue to Cape Blossom Road Construction Project	
<b>File No.:</b> POA-2012-272	
<b>Waterway:</b> Kotzebue Sound	
<b>Proposed Activity:</b> Wetland fill for roadway	
<b>Date:</b> June 2017	Sheet 30 of 43

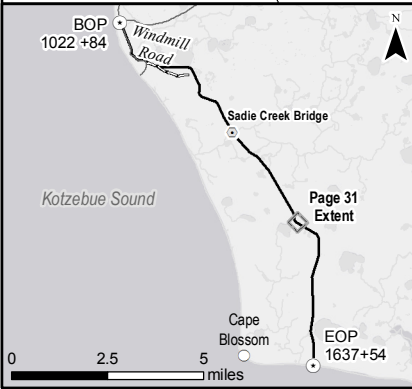
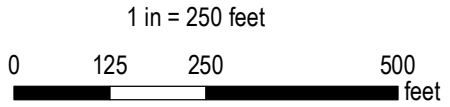
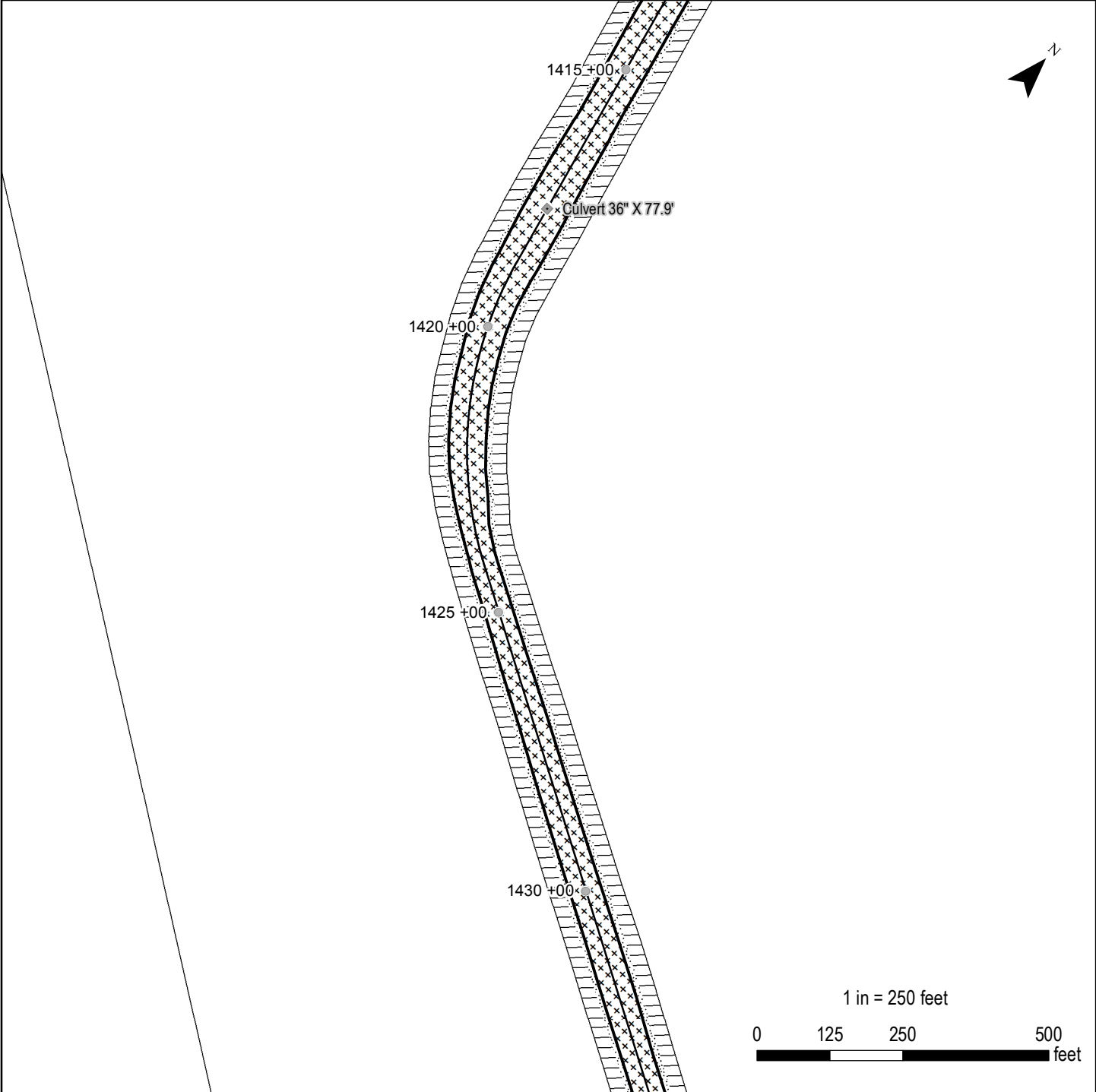

● Station	— Kotzebue Cape Blossom Road
■ Culvert	▭ Project Footprint

**Impacts**

**Wetland**

▨ Fill

▩ Temporary Work Zone

▧ Vegetative Buffer

□ No impact

<b>Plan View</b>	
<b>Applicant:</b> STATE OF ALASKA Department of Transportation and Public Facilities 2301 Peger Rd. Fairbanks, AK 99709	
Kotzebue to Cape Blossom Road Construction Project	
<b>File No.:</b> POA-2012-272	
<b>Waterway:</b> Kotzebue Sound	
<b>Proposed Activity:</b> Wetland fill for roadway	
<b>Date:</b> June 2017	Sheet 31 of 43



1435 +00  
1440 +00  
1445 +00  
1450 +00

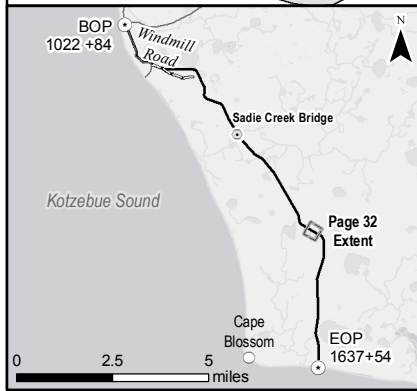
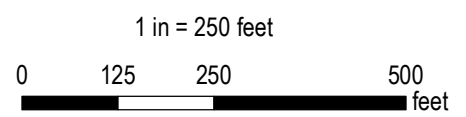

● Station      — Kotzebue Cape Blossom Road  
 □ Project Footprint

**Impacts**

**Wetland**  
 ▤▤▤▤ Fill  
 ▨▨▨▨ Temporary Work Zone  
 ▩▩▩▩ Vegetative Buffer  
 □ No impact

**Upland/Disturbed**  
 □ No impact

**Plan View**

<b>Applicant:</b> STATE OF ALASKA Department of Transportation and Public Facilities 2301 Peger Rd. Fairbanks, AK 99709	
Kotzebue to Cape Blossom Road Construction Project	
<b>File No.:</b> POA-2012-272	
<b>Waterway:</b> Kotzebue Sound	
<b>Proposed Activity:</b> Wetland fill for roadway	
<b>Date:</b> June 2017	Sheet 32 of 43



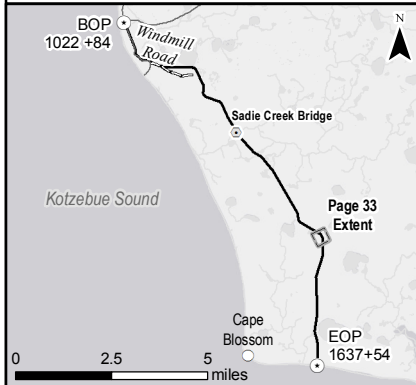
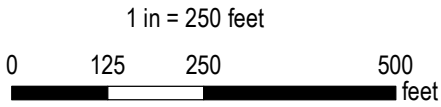
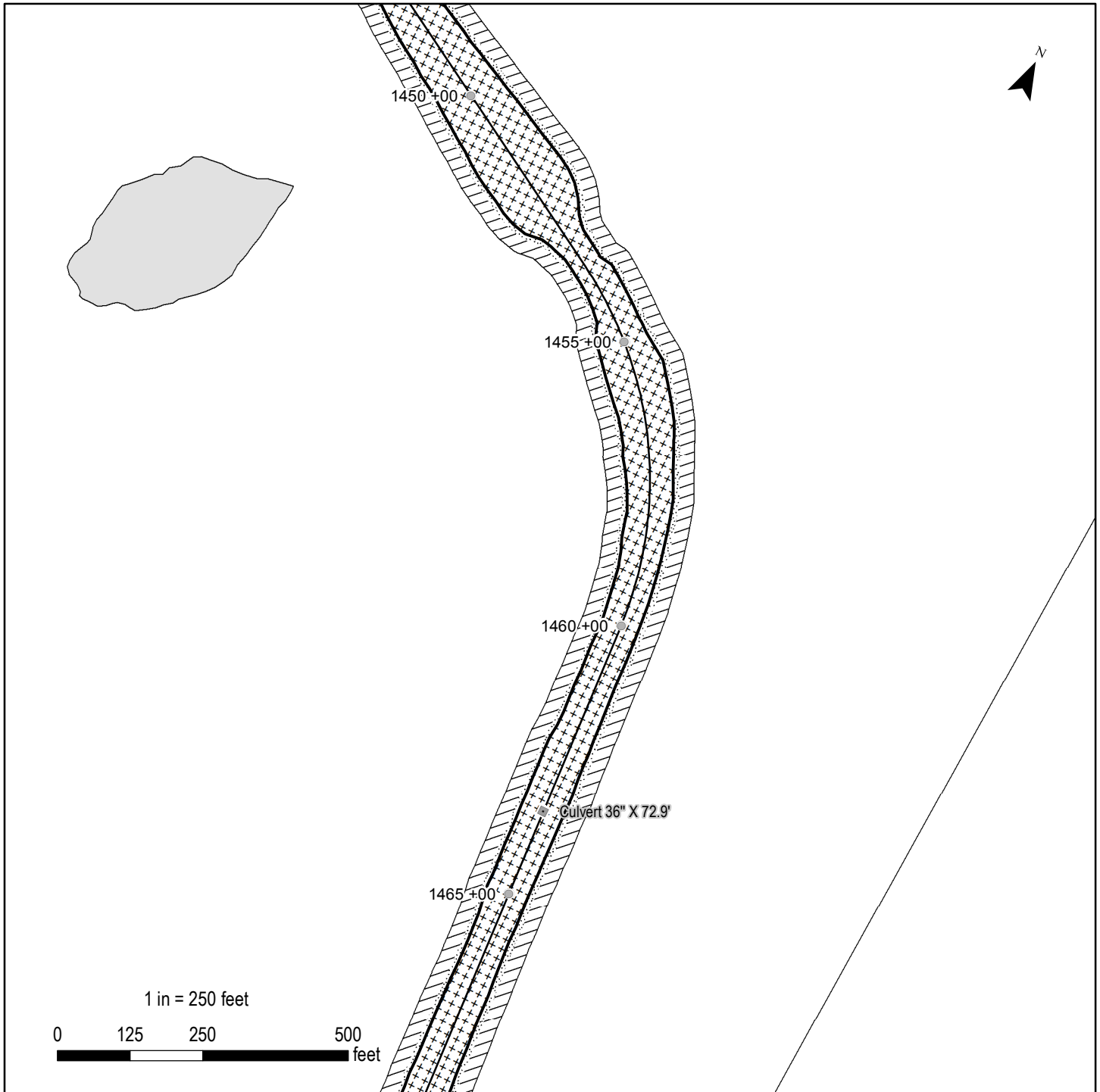

● Station	— Kotzebue Cape Blossom Road
■ Culvert	▭ Project Footprint

**Impacts**

**Wetland**

- +++ Fill
- Temporary Work Zone
- Vegetative Buffer
- No impact

**Upland/Disturbed**

- No impact

**Plan View**

<b>Applicant:</b> STATE OF ALASKA Department of Transportation and Public Facilities 2301 Peger Rd. Fairbanks, AK 99709	
Kotzebue to Cape Blossom Road Construction Project	
<b>File No.:</b> POA-2012-272	
<b>Waterway:</b> Kotzebue Sound	
<b>Proposed Activity:</b> Wetland fill for roadway	
<b>Date:</b> June 2017	Sheet 33 of 43

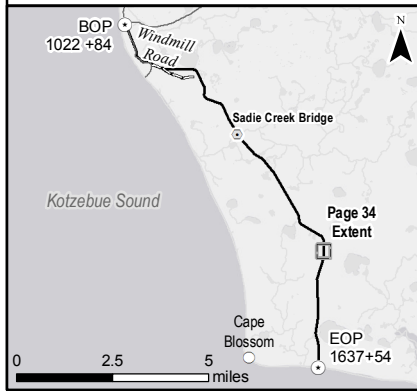
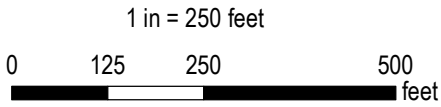
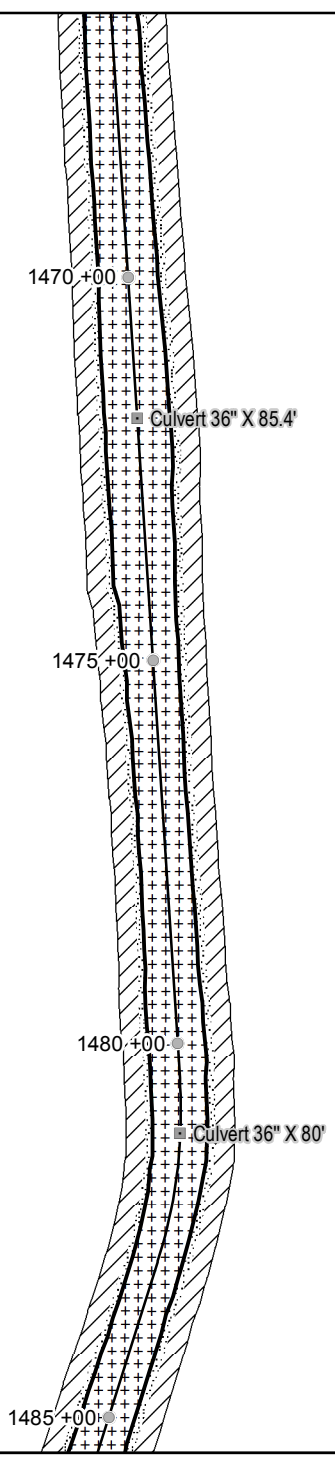

- Station
  - Culvert
  - Kotzebue Cape Blossom Road
  - ▭ Project Footprint
- Impacts**
- Wetland**
- +++ Fill
  - ⊞ Temporary Work Zone
  - /// Vegetative Buffer
  - No impact

**Plan View**

**Applicant:** STATE OF ALASKA  
Department of Transportation and Public Facilities  
2301 Peger Rd. Fairbanks, AK 99709

Kotzebue to Cape Blossom  
Road Construction Project

**File No.:** POA-2012-272

**Waterway:** Kotzebue Sound

**Proposed Activity:** Wetland fill for roadway

**Date:** June 2017

Sheet 34 of 43

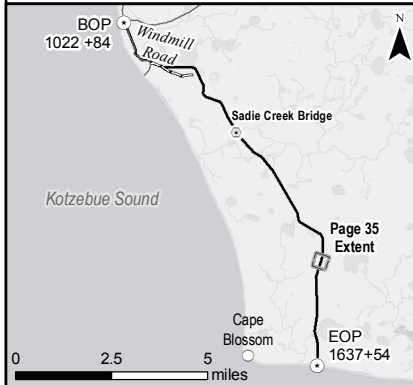
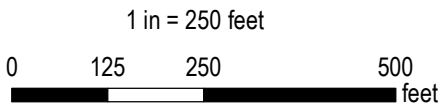
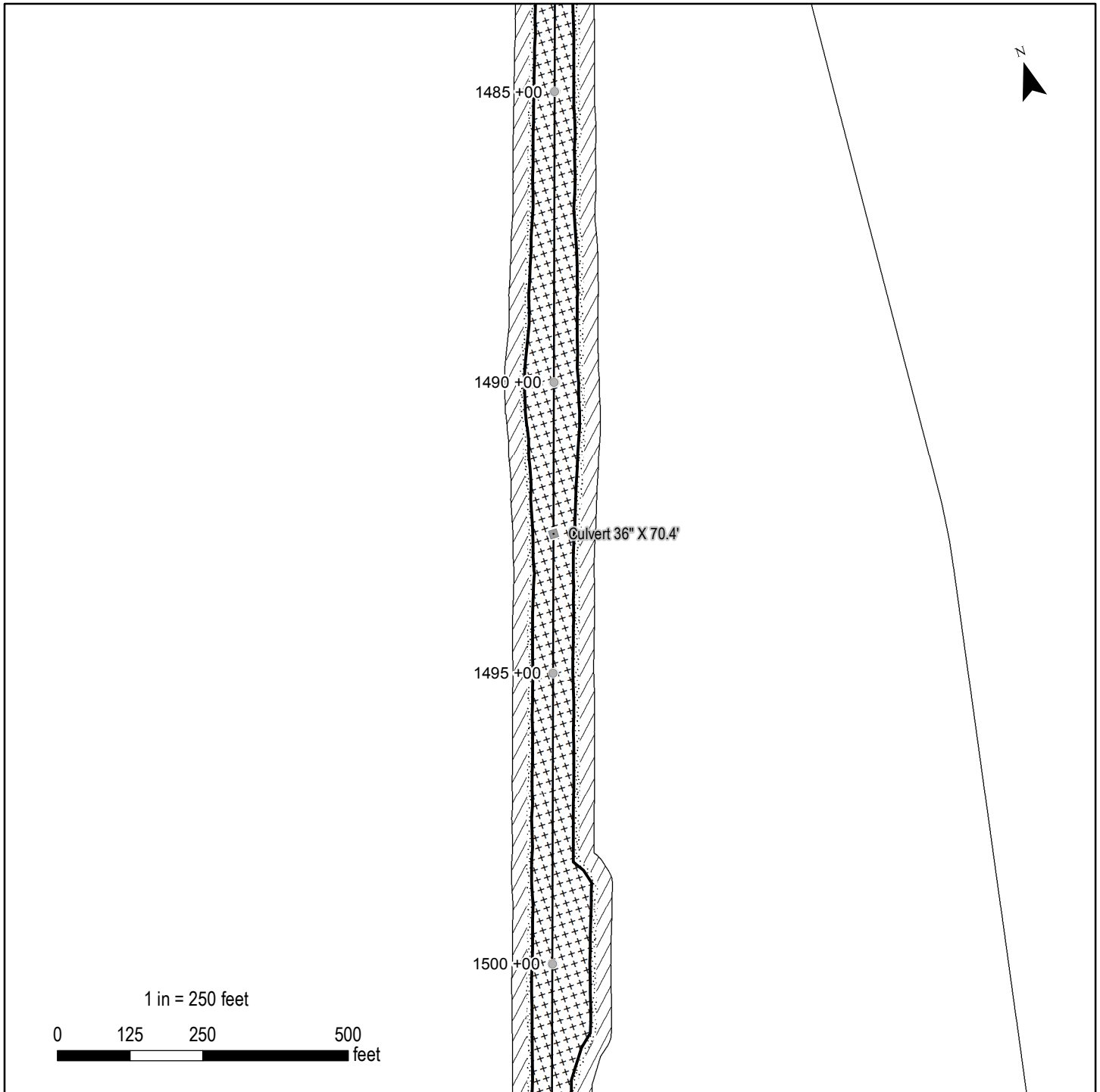

● Station	— Kotzebue Cape Blossom Road
■ Culvert	▭ Project Footprint

**Impacts**

**Wetland**

- +++ Fill
- ⊞ Temporary Work Zone
- /// Vegetative Buffer
- No impact

**Plan View**

<b>Applicant:</b> STATE OF ALASKA Department of Transportation and Public Facilities 2301 Peger Rd. Fairbanks, AK 99709	
Kotzebue to Cape Blossom Road Construction Project	
<b>File No.:</b> POA-2012-272	
<b>Waterway:</b> Kotzebue Sound	
<b>Proposed Activity:</b> Wetland fill for roadway	
<b>Date:</b> June 2017	Sheet 35 of 43

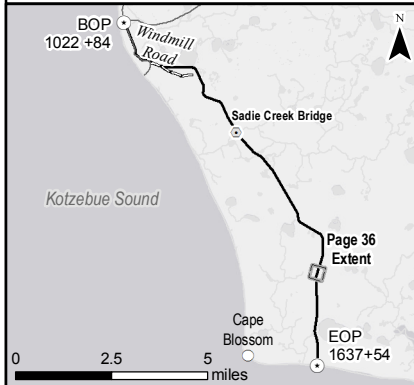
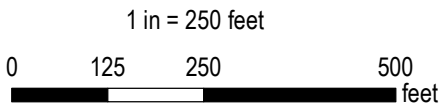
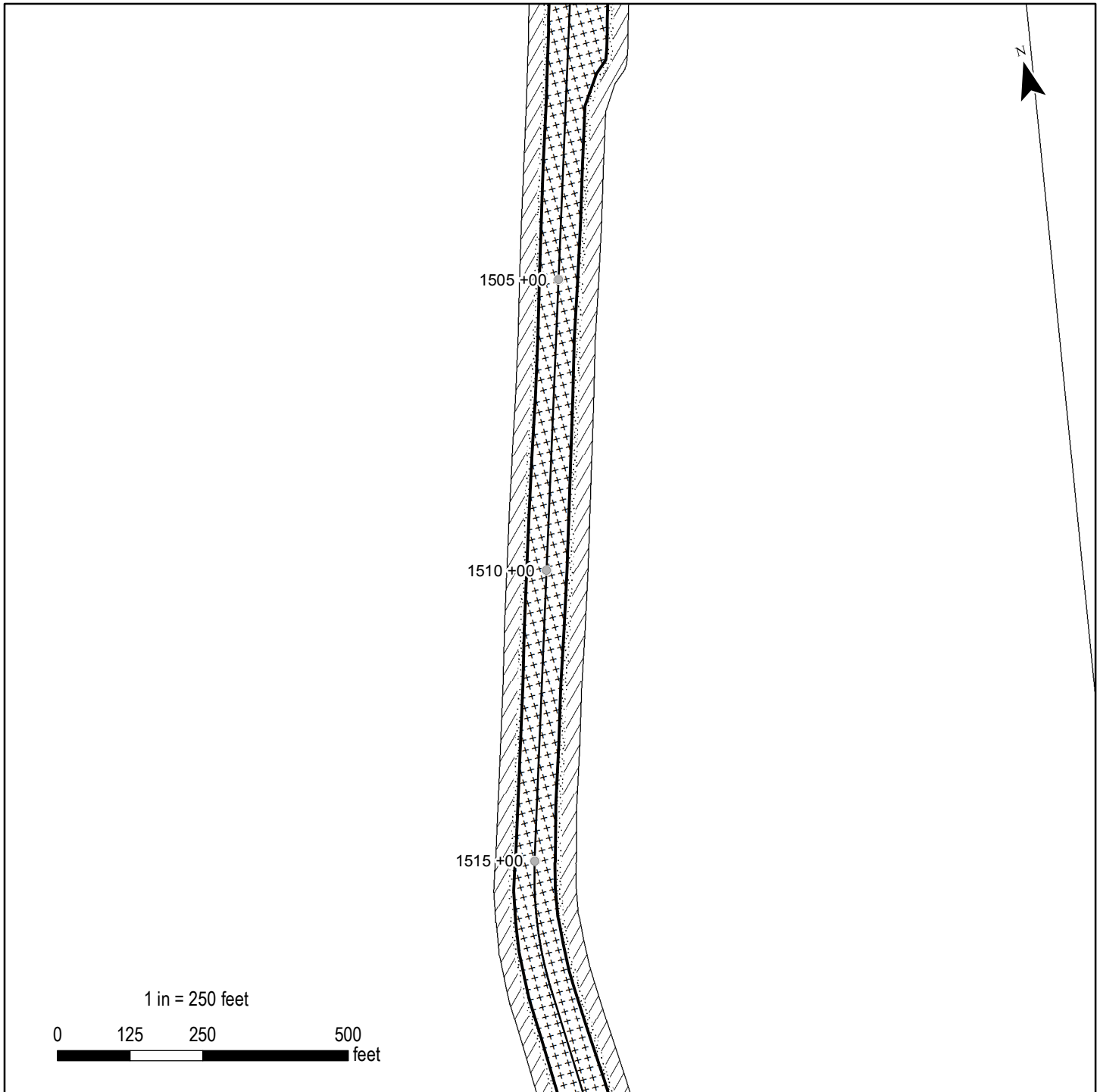

● Station      — Kotzebue Cape Blossom Road  
 □ Project Footprint

**Impacts**

**Wetland**

+++ Fill  
 Temporary Work Zone  
 // Vegetative Buffer  
 □ No impact

**Plan View**

<b>Applicant:</b>	
STATE OF ALASKA Department of Transportation and Public Facilities 2301 Peger Rd. Fairbanks, AK 99709	
Kotzebue to Cape Blossom Road Construction Project	
<b>File No.:</b> POA-2012-272	
<b>Waterway:</b> Kotzebue Sound	
<b>Proposed Activity:</b> Wetland fill for roadway	
<b>Date:</b> June 2017	Sheet 36 of 43

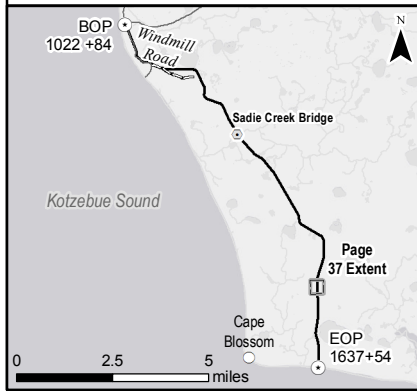
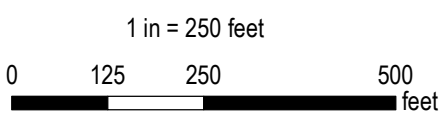
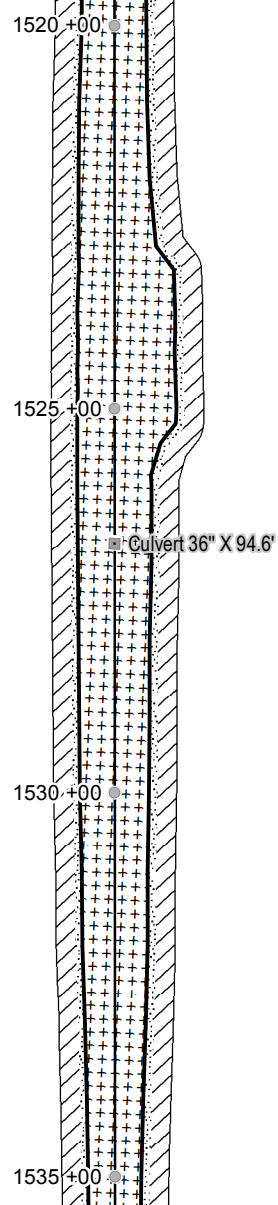

● Station  
 ■ Culvert  
 — Kotzebue Cape Blossom Road  
 □ Project Footprint

**Impacts**

**Wetland**

+++ Fill  
 Temporary Work Zone  
 // Vegetative Buffer  
 □ No impact

**Plan View**

<b>Applicant:</b>	
STATE OF ALASKA Department of Transportation and Public Facilities 2301 Peger Rd. Fairbanks, AK 99709	
Kotzebue to Cape Blossom Road Construction Project	
<b>File No.:</b> POA-2012-272	
<b>Waterway:</b> Kotzebue Sound	
<b>Proposed Activity:</b> Wetland fill for roadway	
<b>Date:</b> June 2017	Sheet 37 of 43

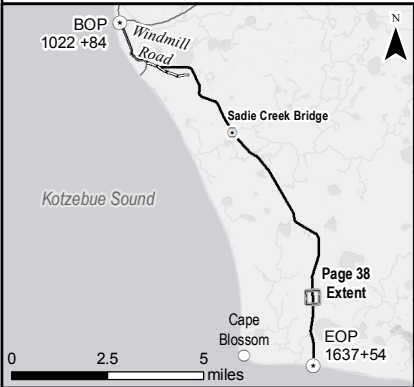
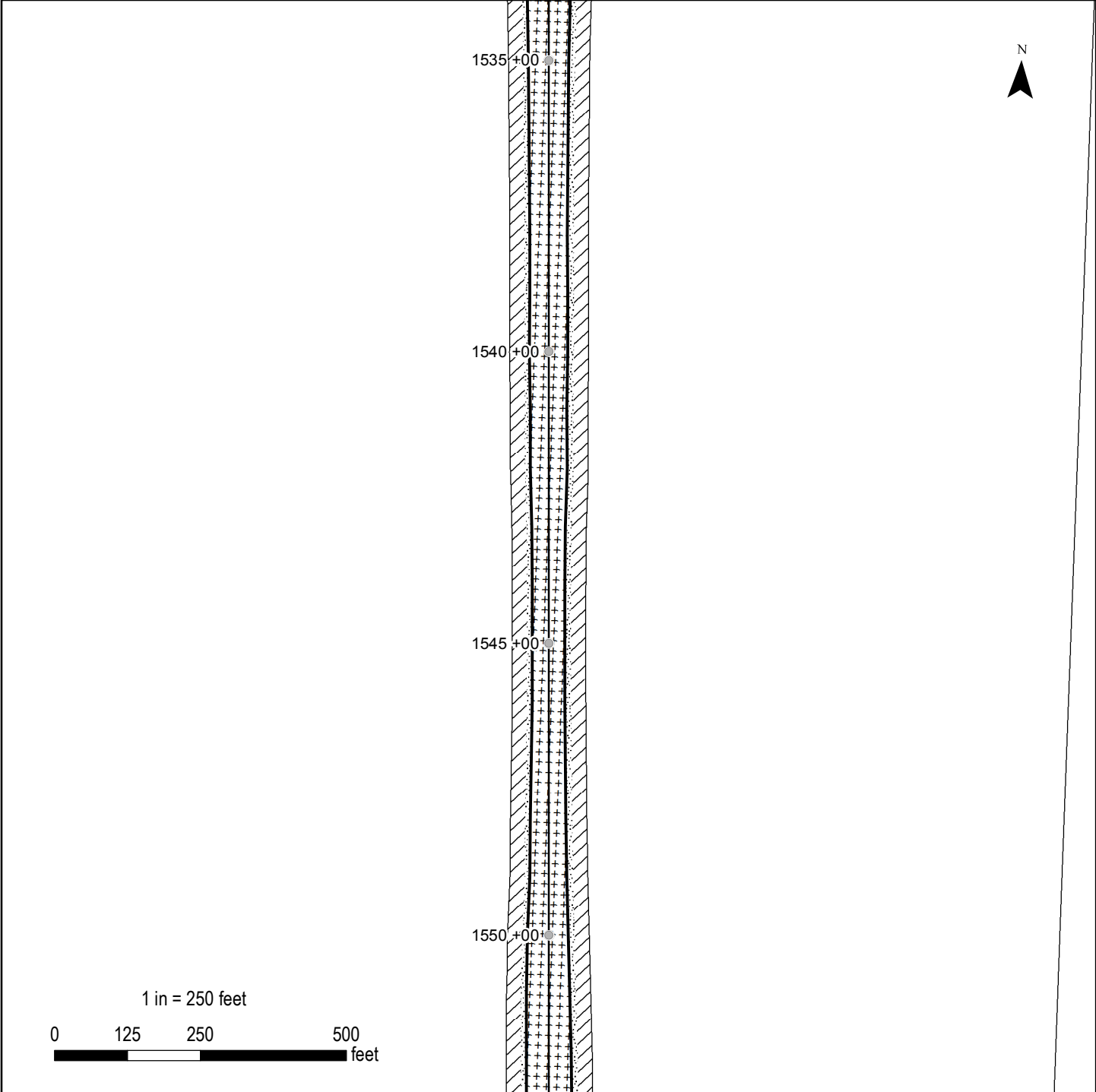

● Station      — Kotzebue Cape Blossom Road  
 □ Project Footprint

**Impacts**

**Wetland**

+++ Fill  
 Temporary Work Zone  
 // Vegetative Buffer  
 □ No impact

<b>Plan View</b>	
<b>Applicant:</b> STATE OF ALASKA Department of Transportation and Public Facilities 2301 Peger Rd. Fairbanks, AK 99709	
Kotzebue to Cape Blossom Road Construction Project	
<b>File No.:</b> POA-2012-272	
<b>Waterway:</b> Kotzebue Sound	
<b>Proposed Activity:</b> Wetland fill for roadway	
<b>Date:</b> June 2017	Sheet 38 of 43

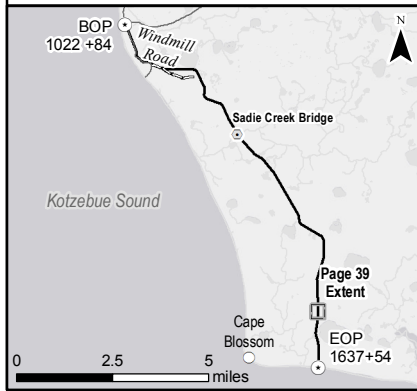
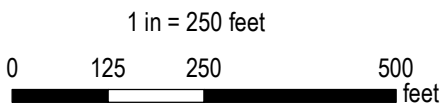
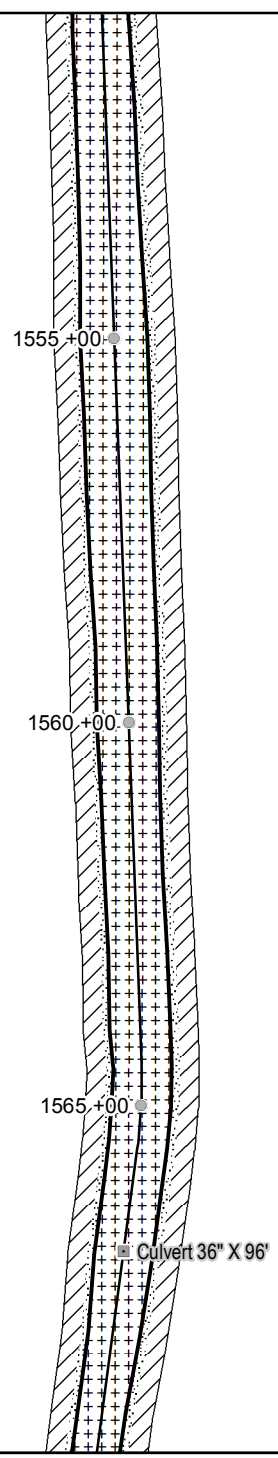

● Station  
 ■ Culvert  
 — Kotzebue Cape Blossom Road  
 □ Project Footprint

**Impacts**

**Wetland**

+++ Fill  
 Temporary Work Zone  
 // Vegetative Buffer  
 □ No impact

**Plan View**

<b>Applicant:</b> STATE OF ALASKA Department of Transportation and Public Facilities 2301 Peger Rd. Fairbanks, AK 99709	
Kotzebue to Cape Blossom Road Construction Project	
<b>File No.:</b> POA-2012-272	
<b>Waterway:</b> Kotzebue Sound	
<b>Proposed Activity:</b> Wetland fill for roadway	
<b>Date:</b> June 2017	Sheet 39 of 43

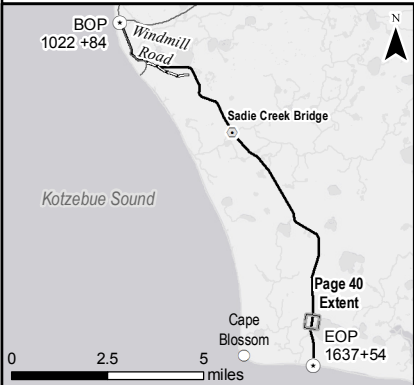
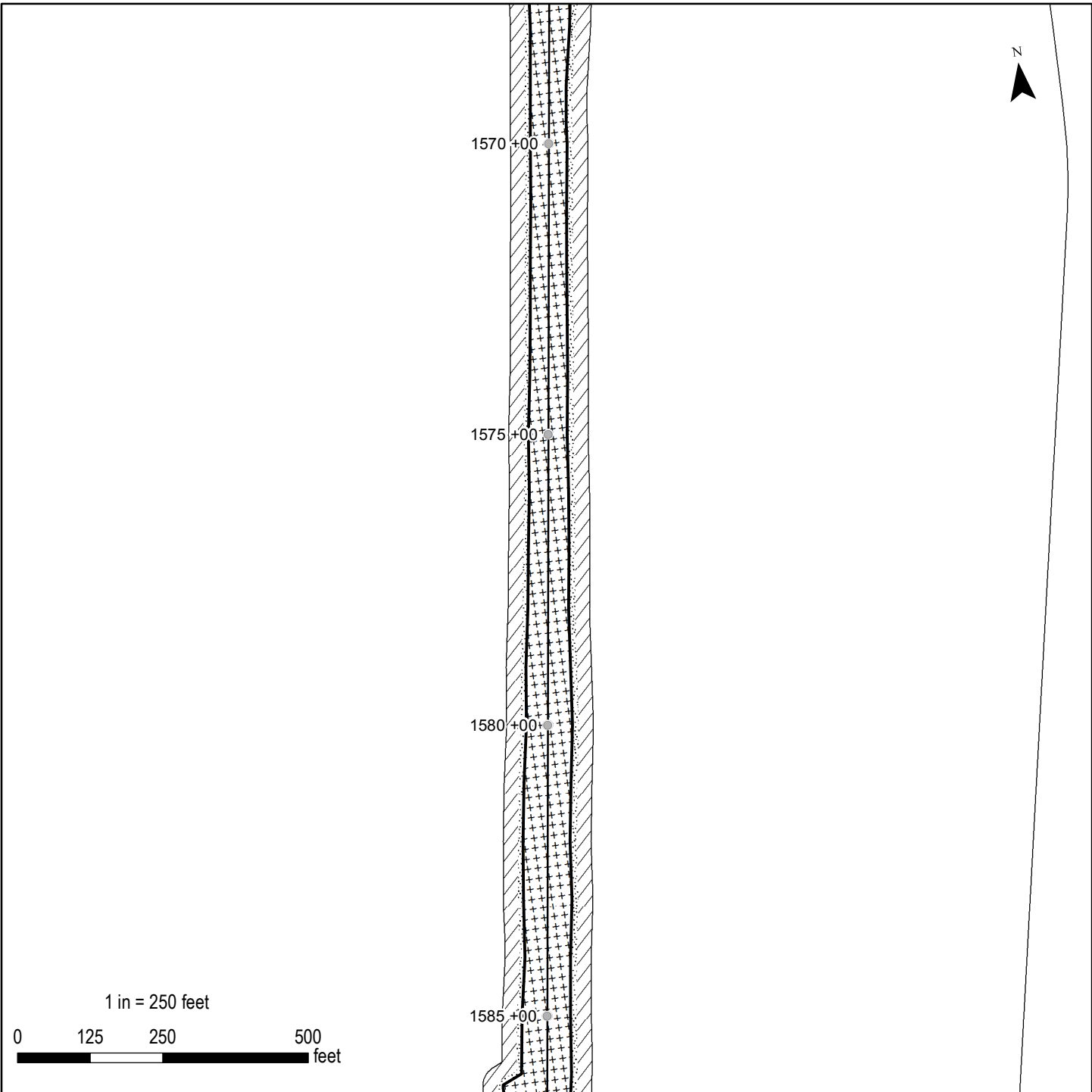

- Station
- Kotzebue Cape Blossom Road
- ▭ Project Footprint

**Impacts**

**Wetland**

- +++ Fill
- ⊘ Temporary Work Zone
- /// Vegetative Buffer
- No impact

<b>Plan View</b>	
<b>Applicant:</b> STATE OF ALASKA Department of Transportation and Public Facilities 2301 Peger Rd. Fairbanks, AK 99709	
Kotzebue to Cape Blossom Road Construction Project	
<b>File No.:</b> POA-2012-272	
<b>Waterway:</b> Kotzebue Sound	
<b>Proposed Activity:</b> Wetland fill for roadway	
<b>Date:</b> June 2017	Sheet 40 of 43



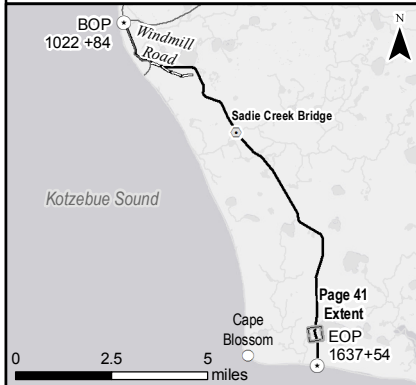
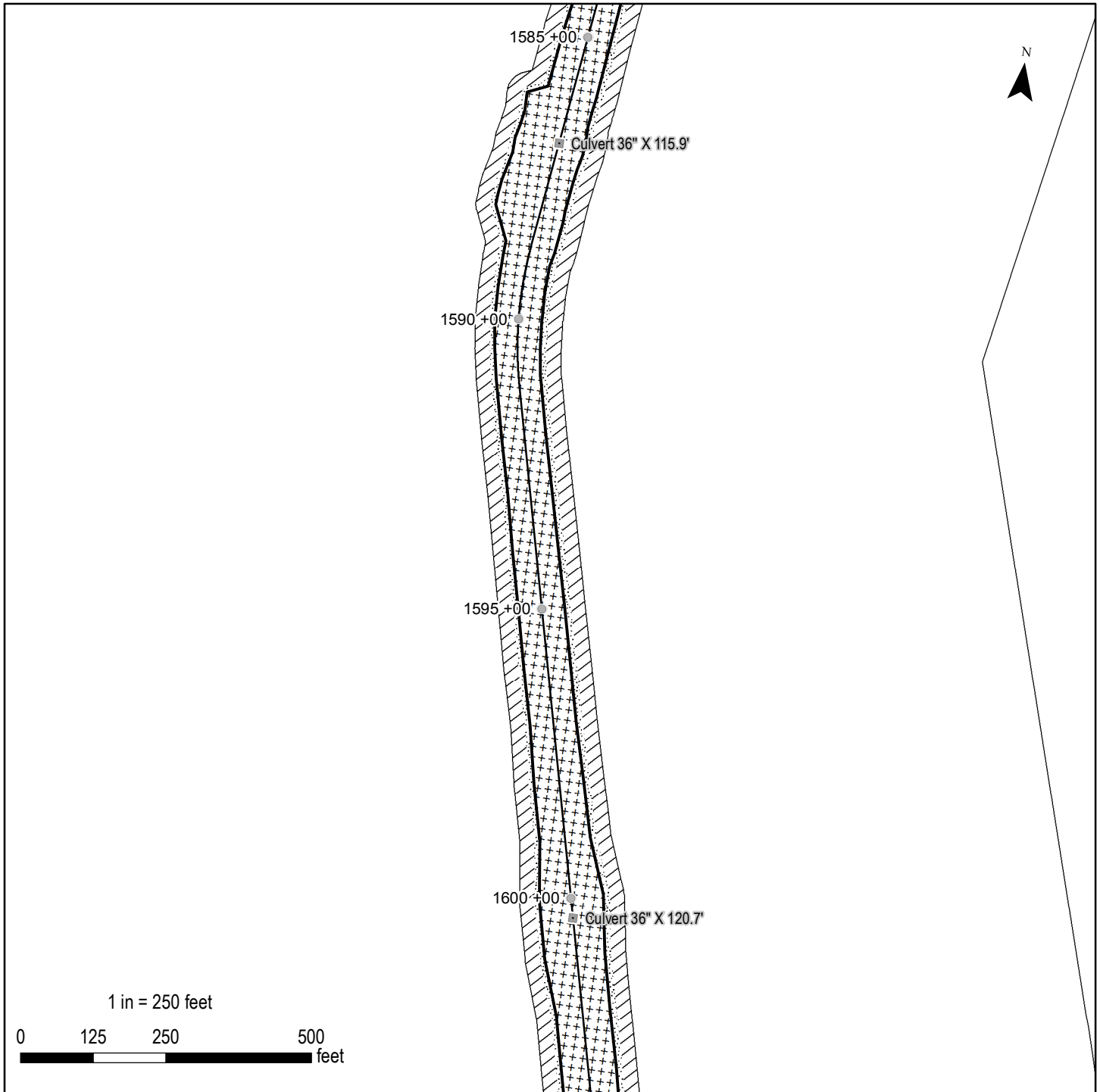

- Station
- Culvert
- Kotzebue Cape Blossom Road
- ▭ Project Footprint

**Impacts**

**Wetland**

- +++ Fill
- ⊞ Temporary Work Zone
- /// Vegetative Buffer
- No impact

<b>Plan View</b>	
<b>Applicant:</b> STATE OF ALASKA Department of Transportation and Public Facilities 2301 Peger Rd. Fairbanks, AK 99709	
Kotzebue to Cape Blossom Road Construction Project	
<b>File No.:</b> POA-2012-272	
<b>Waterway:</b> Kotzebue Sound	
<b>Proposed Activity:</b> Wetland fill for roadway	
<b>Date:</b> June 2017	Sheet 41 of 43

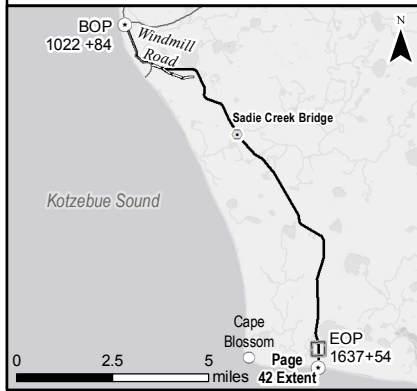
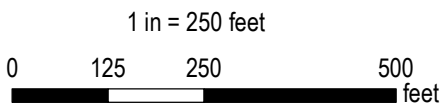
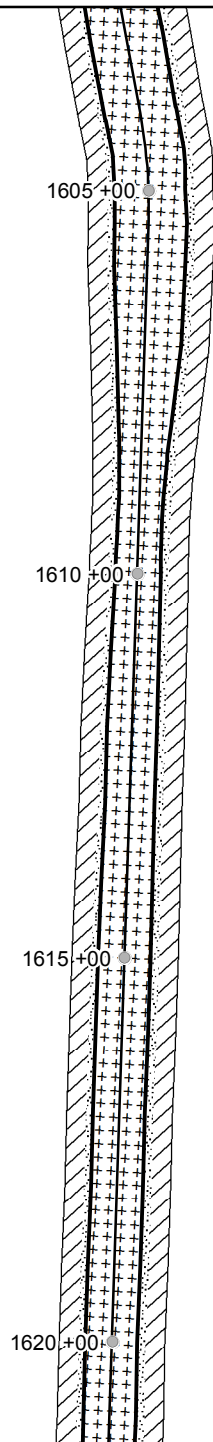

● Station

— Kotzebue Cape Blossom Road

▭ Project Footprint

**Impacts**

**Wetland**

+++ Fill

⊞ Temporary Work Zone

/// Vegetative Buffer

□ No impact

**Upland/Disturbed**

□ No impact

**Plan View**

<b>Applicant:</b> STATE OF ALASKA Department of Transportation and Public Facilities 2301 Peger Rd. Fairbanks, AK 99709	
Kotzebue to Cape Blossom Road Construction Project	
<b>File No.:</b> POA-2012-272	
<b>Waterway:</b> Kotzebue Sound	
<b>Proposed Activity:</b> Wetland fill for roadway	
<b>Date:</b> June 2017	Sheet 42 of 43

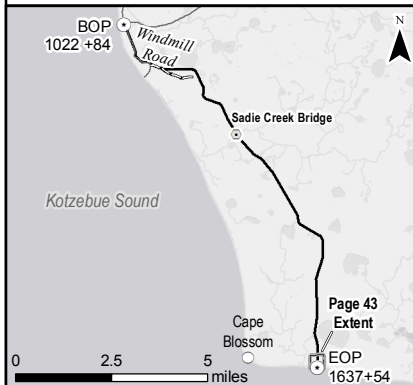
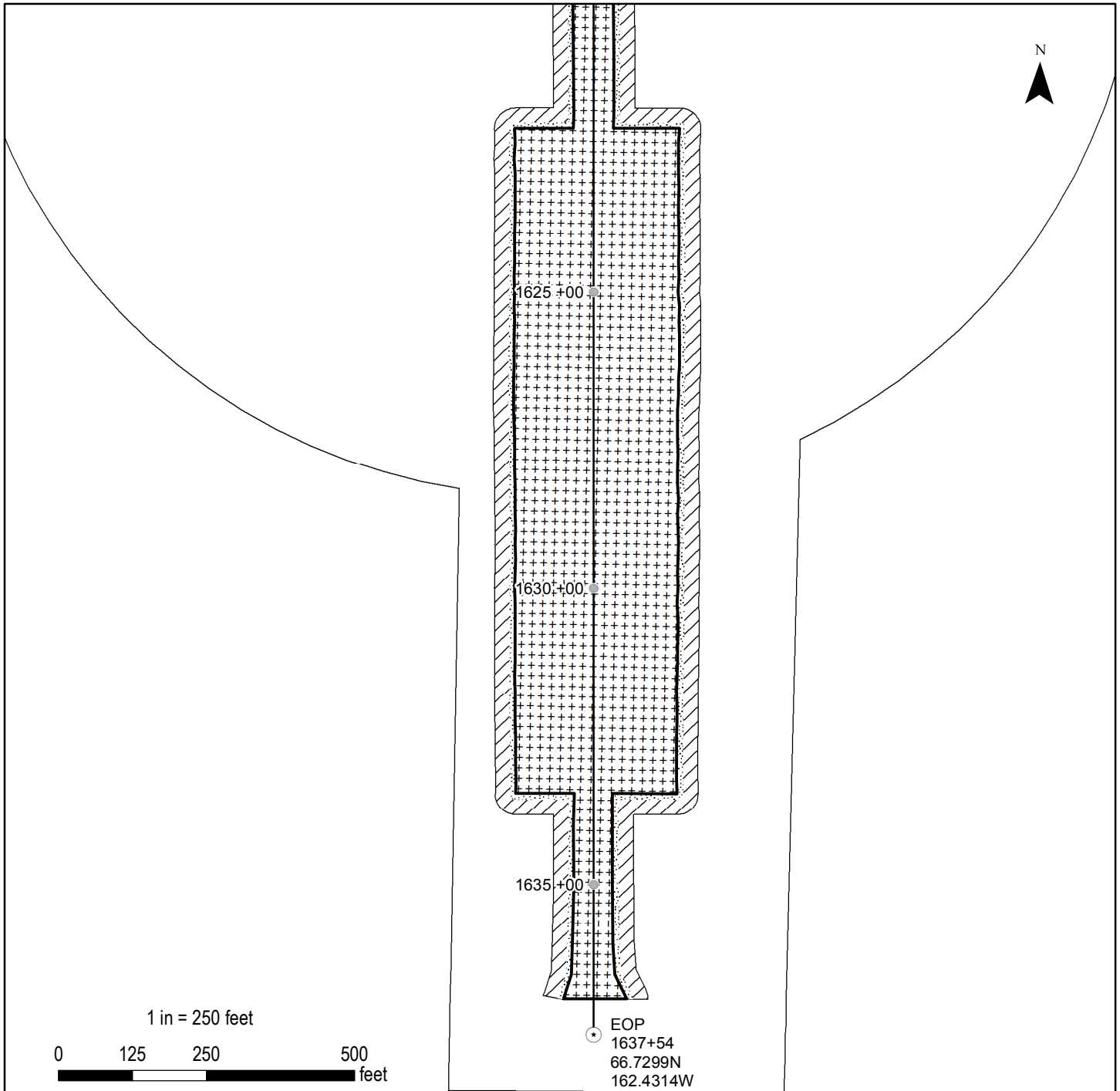

- ⊙ Project Location
  - Station
  - Kotzebue Cape Blossom Road
  - ▭ Project Footprint
- Impacts**
- Wetland**
- +++ Fill
  - ⊞ Temporary Work Zone
  - /// Vegetative Buffer
  - No impact

**Plan View**

**Applicant:** STATE OF ALASKA  
 Department of Transportation and Public Facilities  
 2301 Peger Rd. Fairbanks, AK 99709

Kotzebue to Cape Blossom  
 Road Construction Project

**File No.:** POA-2012-272

**Waterway:** Kotzebue Sound

**Proposed Activity:** Wetland fill for roadway

**Date:** June 2017

Sheet 43 of 43