

# Airport Master Plan

## Dillingham Airport Master Plan Update

Project No. CFAPT00353/ AIP 3-02-0078-017-2018

Prepared for:



Alaska Department of Transportation & Public Facilities  
4111 Aviation Avenue  
Anchorage, Alaska 99502

Prepared by:

R&M Consultants, Inc.  
9101 Vanguard Drive  
Anchorage AK, 99507

May 2023

The preparation of this document is supported in part with financial assistance through the Airport Improvement Program from the Federal Aviation Administration (AIP Grant Number 3-02-0078-017-2018) as provided under Title 49 USC § 47104. The contents do not necessarily reflect the official views or policy of the FAA. Acceptance of this report by the FAA does not in any way constitute a commitment on the part of the United States to participate in any development depicted therein, nor does it indicate that the proposed development is environmentally acceptable in accordance with the appropriate public laws.

## Table of Contents

1.0 Introduction .....	1
2.0 Public Involvement.....	1
3.0 Background .....	2
3.1 Community Profile .....	2
3.2 Location and Regional Setting.....	2
3.3 Dillingham Airport Background and History .....	4
3.4 Airport Role in the Community and Regional Infrastructure.....	6
4.0 Existing Conditions.....	7
4.1 Airfield/Airspace .....	8
4.1.1 Airport Reference Code .....	8
4.1.2 Runways.....	8
4.1.3 Lighting, Approach Aids, and Nav aids.....	9
4.1.4 Obstruction Data.....	12
4.1.5 Aprons .....	13
4.1.6 Taxiways.....	13
4.1.7 Services/Navcom.....	14
4.2 Commercial Passenger Terminal Facilities.....	14
4.3 General Aviation Facilities.....	17
4.4 Cargo Facilities .....	18
4.5 Support Facilities.....	18
4.6 Access, Circulation, and Parking .....	21
4.7 Utilities .....	22
4.8 Recycling and Solid Waste Minimization .....	23
4.9 Land Ownership and Use .....	24
4.9.1 Airport Layout Plan (2016).....	26
4.9.2 City of Dillingham Land Use Planning .....	27
4.10 Environmental Conditions .....	28
4.10.1 Aquatic Conditions.....	29
4.10.2 Terrestrial Conditions.....	31
4.10.3 Cultural Considerations.....	33
4.11 Socioeconomic Conditions .....	33
4.11.1 Population.....	34
4.11.2 Demographics .....	35
4.11.3 Employment and Economy .....	37

---

4.11.4 Commercial Fishing Activity .....	38
5.0 Aviation Activity Forecast .....	39
5.1 Forecast Results Summary .....	40
5.2 Aviation Activity .....	40
5.2.1 General Aviation and Military Operations .....	40
5.2.2 Air Cargo.....	41
5.2.3 Passenger Volumes .....	43
5.2.4 Factors Affecting Activity .....	44
5.3 Aircraft Operations .....	44
5.3.1 Factors Affecting Operations .....	46
5.4 Forecast Scenarios .....	47
5.4.1 Low Growth Scenario .....	48
5.4.2 Base Growth Scenario .....	48
5.4.3 High Growth Scenario .....	49
5.4.4 Air Cargo Fleet Change Scenario.....	49
5.4.5 Comparison with Federal Aviation Administration Forecast .....	50
5.4.6 Fresh Sockeye Growth Scenario.....	50
5.5 Critical Aircraft .....	57
6.0 Demand-Capacity Analysis.....	57
6.1 Average Hourly Capacity .....	58
6.2 Annual Service Volume .....	59
7.0 Facility Requirements .....	60
8.0 Alternatives Development & Evaluation.....	68
8.1 RSA Alternatives.....	68
8.1.1 Site Constraints and RSA Impact Considerations.....	69
8.1.2 Alternative Evaluation.....	71
8.1.3 Alternative 1: Offset RW 150' West.....	71
8.1.4 Alternative 2: Offset RW 150' West, Shift RW 1 Threshold 400' North.....	72
8.1.5 Alternative 3: Expand Existing RSA .....	72
8.1.6 Alternative 4: No Build, Publish Declared Distances.....	72
8.1.7 Recommended Alternative .....	72
8.2 Non-RSA Alternatives.....	74
8.2.1 Crosswind Runway.....	74
8.2.2 Shared Terminal Facility.....	75
8.2.3 Expanded Terminal Apron .....	75

---

8.2.4 No-Taxi Islands / Offset Taxiway .....	76
8.2.5 Turnarounds .....	76
9.0 Airport Layout Plan .....	77
10.0 Financial Feasibility Analysis .....	78
10.1 Sources of Funding .....	78
10.1.1 Airport Revenue .....	78
10.1.2 Federal Aviation Administration Airport Improvement Program .....	78
10.1.3 Passenger Facility Charges .....	80
10.1.4 State of Alaska Rural Airport Improvement Program .....	80
10.1.5 Landing Fees .....	81
10.1.6 Municipal Contributions .....	81
10.2 Capital Improvement Program .....	81

**List of Figures**

Figure 1: DLG Location & Vicinity Map .....	3
Figure 2: DLG Project Area .....	7
Figure 3: ODALS North of RW 19 .....	10
Figure 4: ODALS North of RW 19, Close-up .....	11
Figure 5: Localizer South of RW 01 .....	12
Figure 6: Alaska Airlines/Ravn Air Terminal Building Exterior .....	15
Figure 7: Baggage Claim Area, Alaska Airlines/Ravn Air Terminal Building .....	15
Figure 8: Ticketing Area, Alaska Airlines/Ravn Air Terminal Building .....	16
Figure 9: Waiting Area, Alaska Airlines/Ravn Air Terminal Building .....	16
Figure 10: Freight Delivery at DLG .....	18
Figure 11: Flight Service Station .....	19
Figure 12: ARFF/SERB .....	19
Figure 13: Long Term Parking Lot at DLG .....	21
Figure 14: City of Dillingham Land Ownership Map. Source: City of Dillingham Parcels (2021 GIS) .....	25
Figure 15: Current Land Use Near DLG. Source: City of Dillingham Parcels (2021 GIS) .....	26
Figure 16: Land Use Designations, City of Dillingham Comprehensive Plan (2010) .....	28
Figure 17: ADEC Drinking Water Protection Area Mapper .....	30
Figure 18: National Wetlands Inventory Map .....	31
Figure 19: DLG Contaminated Areas Map .....	32
Figure 20: DLG Total Freight Summary, 2010-2019 .....	41
Figure 21: DLG Total Mail Summary, 2010-2019 .....	42
Figure 22: Total Passengers at DLG, 2010-2019 .....	43
Figure 23: Annual Bristol Bay Fresh Sockeye Processed, thousand lbs. vs. Annual DLG Operations .....	51
Figure 24: Seasonal Air Cargo from Dillingham to Anchorage, thousand lbs., 2010-2020 .....	52
Figure 25: Dillingham Airport Historical Annual Freight Volumes, 2010-2019 .....	52
Figure 26: Air Passengers from Dillingham to Anchorage, Number of Passengers, 2010-2020 .....	54
Figure 27: Air Passengers from Anchorage to Dillingham, Number of Passengers, 2010-2020 .....	54
Figure 28: Bristol Bay Sockeye, by Processing Type, Million lbs., 2010-2019 .....	55
Figure 29: Projected Annual Airfreight from Dillingham to Anchorage, Pounds, 2020, 2025, 2030, and 2040 .....	56

Figure 30: TranStats: DLG (2019) ..... 60  
Figure 31: Abandoned Vehicle in Long-Term Parking Lot..... 65  
Figure 32: Saturated Land, RW 1 End Looking Southeast..... 66  
Figure 33: RSA Embankment Slope, RW 1 End Looking Southeast..... 66  
Figure 34: Culvert by GA Apron Access Point ..... 67  
Figure 35: Surface Irregularities in the Tundra Surrounding the Airport Embankment ..... 67  
Figure 36: Evergreen Cemetery ..... 68  
Figure 37: Existing RSA Dimensions ..... 69  
Figure 38: Kakanak Road within OFA ..... 69  
Figure 39: Wood River Road within OFA ..... 70  
Figure 40: Evergreen Cemetery within OFA..... 70  
Figure 41: Alternative 1..... 71  
Figure 42: Alternative 2..... 72  
Figure 43: Alternative 3..... 72  
Figure 44: Alternative 4..... 72  
Figure 45: No-Taxi Islands ..... 76  
Figure 46: Taxiway Offset from Apron..... 76  
Figure 47: Turnaround Taxiways..... 77  
Figure 48: Proposed Future Layout..... 77

**List of Tables**

Table 1: AIP Capital Improvements Since 2005 AMP..... 4  
Table 2: Runway 1-19..... 8  
Table 3: Runway 1-19 Pavement Load Rating ..... 8  
Table 4: Runway 1-19 Lighting & Approach Aids ..... 9  
Table 5: Runway 1-19 Nav aids ..... 9  
Table 6: Runway 1-19 Obstacles ..... 13  
Table 7: DLG Aprons..... 13  
Table 8: DLG Taxiways..... 14  
Table 9: DLG Aeronautical Services & Facilities ..... 14  
Table 10: DLG Based Aircraft (2020)..... 17  
Table 11: Fuel Storage at DLG ..... 20  
Table 12: Wind Data..... 27  
Table 13: Drinking Water Protection Area Mapper Legend ..... 30  
Table 14: DLG Contaminated Sites & Status ..... 32  
Table 15: DLG Recorded Spills..... 33  
Table 16: Population Counts, Dillingham Census Area, Bristol Bay Borough, and Lake and Peninsula Borough, 2010-2019 ..... 34  
Table 17: Population Counts, Dillingham Census Area, Bristol Bay Borough, and Lake and Peninsula Borough, by 1960-2010 Census Year ..... 35  
Table 18: Population by Race, Dillingham Census Area, Bristol Bay Borough, and Lake and Peninsula Borough, Percent of Population, 2014-2018 5-Year Estimates ..... 35  
Table 19: Population by Age Cohort, Dillingham Census Area, Bristol Bay Borough, and Lake and Peninsula Borough, 2019 ..... 36  
Table 20: Current Population by Sex, Dillingham Census Area, Bristol Bay Borough, and Lake and Peninsula Borough, 2014-2018 5-Year Estimates ..... 36  
Table 21: Income and Poverty, Dillingham Census Area, Bristol Bay Borough, and Lake and Peninsula Borough, 2014-2018 5-Year Estimates ..... 37

Table 22: Employment by Sector in Number of Jobs, Dillingham Census Area, Bristol Bay Borough, and Lake and Peninsula Borough, 2018.....	38
Table 23: Residents’ Commercial Fishing Participation and Earnings, Dillingham Census Area, Bristol Bay Borough, and Lake and Peninsula Borough, 2012-2018.....	39
Table 24: Current and Ultimate Critical Aircraft .....	40
Table 25: DLG Total Freight Summary, 2010-2019 .....	41
Table 26: DLG Total Mail Summary, 2010-2019 .....	42
Table 27: Passenger Levels at DLG, 2010-2019 .....	43
Table 28: Aircraft Approach Category (AAC) .....	45
Table 29: Airplane Design Group (ADG).....	45
Table 30: Annual DLG Operations by Aircraft, AAC, and ADG (2019).....	45
Table 31: Alaska Statewide and Local Area Population Annual Average Growth Rate Projections, 2020 to 2040 (Percent Change).....	47
Table 32: 2019 to 2040 DLG Aircraft Operations Forecast: Low Growth Scenario .....	48
Table 33: 2019-2040 DLG Aircraft Operations Forecast: Base Growth Scenario.....	48
Table 34: 2019-2040 DLG Aircraft Operations Forecast: High Growth Scenario.....	49
Table 35: Northern Air Cargo Fleet, DLG Operations (2019) .....	49
Table 36: Northern Air Cargo Fleet Change Effect on DLG Operations, by ARC Category .....	50
Table 37: 2019-2040 DLG Aircraft Operations Forecast: Air Cargo Fleet Change Scenario .....	50
Table 38: Hourly Capacity at DLG.....	59
Table 39: Airport Issues .....	60
Table 40: Alternatives Matrix.....	73
Table 41: Alternative Cost Estimates .....	74
Table 42: Wind Coverage .....	74
Table 43: Examples of Eligible vs. Ineligible AIP Projects.....	79
Table 44: Capital Improvement Program.....	82

**Appendices**

- Appendix A: Airport Layout Plan
- Appendix B: Demand-Capacity Analysis
- Appendix C: DLG RSA Practicability Study

**List of Acronyms**

AAC	Aircraft Approach Category
AASP	Alaska Aviation System Plan
ADEC	Alaska Department of Environmental Conservation
ADG	Airplane Design Group
ADF&G	Alaska Department of Fish and Game
ADOLWD	Alaska Department of Labor and Workforce Development
AIP	Airport Improvement Program
ALP	Airport Layout Plan
AMP	Airport Master Plan
AOA	Airport Operations Area
APEB	Aviation Project Evaluation Board
ARC	Airport Reference Code
ARFF	Aircraft Rescue and Fire Fighting
ASDA	Accelerate Stop Distance Available
AST	Alaska State Troopers

ATO	Air Traffic Organization
AWOS	Automated Weather Observing System
CFR	Code of Federal Regulations
DCRA	Division of Community and Regional Affairs
DLG	Dillingham Airport
DME	Distance Measuring Equipment
DNR	Department of Natural Resources
DOT&PF	Department of Transportation and Public Facilities
DWPA	Drinking Water Protection Area
EPA	United States Environmental Protection Agency
FAA	Federal Aviation Administration
FAR	Federal Aviation Regulations
FSS	Flight Service Station
USFWS	United States Fish and Wildlife Services
GA	General Aviation
GIS	Geographic Information Systems
GPS	Global Positioning System
IMC	Instrument Meteorological Conditions
LDA	Landing Distance Available
NAVAID	Navigational Aid
NPI	Non-Precision Instrument
NPIAS	National Plan of Integrated Airport Systems
ODALs	Omni-Directional Approach Lights
PAPI	Precision Approach Path Indicator
PCI	Pavement Condition Index
PFAS	Per- and polyfluoroalkyl substances
PIP	Public Involvement Plan
PM	Particulate Matter
RCRA	Resource Conservation and Recovery Act
REIL	Runway End Identifier Lights
RNAV	Area Navigation
RPZ	Runway Protection Zone
RW	Runway
SAWS	Stand Alone Weather Sensors
SFY	State Fiscal Year
SIDA	Security Identification Display Area
SREB	Snow Removal Equipment Building
SWPPP	Stormwater Pollution Prevention Plan
TSA	Transportation Security Administration
TW	Taxiway
USDI	United States Department of the Interior
VASI	Visual Approach Path Indicator
VGSI	Visual Glide Slope Indicator
VOR	Very High Frequency Omnidirectional Range
VMC	Visual Meteorological Conditions
WELTS	Well Log Tracking System



## 1.0 Introduction

The Alaska Department of Transportation & Public Facilities (DOT&PF) is updating the 2005 Airport Master Plan (AMP) and 2016 Airport Layout Plan (ALP) for Dillingham Airport (DLG) with this project. The previous AMP no longer serves as an effective guide for airport improvements at DLG. The updated AMP and accompanying ALP will provide a plan for capital improvements, maintenance, and operations at DLG over a 20-year planning horizon. It will provide recommendations that allow DLG to continue or improve its service to the City of Dillingham and surrounding communities.

## 2.0 Public Involvement

This section describes the methods used to ensure meaningful public involvement in the AMP update, helping to inform plan recommendations.

### **Public Involvement Plan (PIP)**

A PIP was developed at the beginning of the project to outline the range of tools and techniques to inform potentially interested parties, provide opportunities to gather input early and often, and apply participant when preparing AMP recommendations. The PIP provided a framework to help ensure stakeholders and members of the public:

- Are adequately informed about the project throughout development;
- Have ample opportunity to actively participate in the planning process;
- Receive timely, meaningful responses to their questions, comments, and concerns;
- Provide data and input needed for the project team to assess current and projected facility needs.

### **Project Website**

A project-specific website was established and maintained by DOT&PF to provide a simple way to view project updates and access project documents.

### **Stakeholder & Carrier Interviews**

Stakeholder and carrier interviews provided more in-depth knowledge of airport needs and issues from the perspective of air carriers, business leaders, tribal entities, and service organizations that heavily rely on DLG for their own operations.

### **Public Open Houses**

Two virtual open house meetings enable direct public input. The first open house was held October 22<sup>nd</sup>, 2020. The primary focus was on introducing the project and identifying current issues and opportunities at DLG. Public feedback from this meeting has been incorporated into Table 39: *Airport Issues* below.

The second public open house was held September 29<sup>th</sup>, 2022. This meeting focused on (1) the draft ALP showing the recommended future layout of DLG within the 20-year plan horizon, (2) the Runway Safety Area (RSA) Practicability Study showing the recommended changes needed to ensure the RSA meets Federal Aviation Administration (FAA) standards, and (3) the alternatives considered to support the ALP and RSA Practicability Study.

## 3.0 Background

### 3.1 Community Profile

Dillingham has a highly integrated population of Alaska Natives and non-Natives. Historically, the area around Dillingham was inhabited by both Yup'ik and Athabascans and became a trade center when Russians erected the Alexandrovski Redoubt Post in 1818. Local Native groups and Natives from the Kuskokwim Region, the Alaska Peninsula, and Cook Inlet mixed together as they came to visit or live at the post. The community was known as Nushagak by 1837, when a Russian Orthodox mission was established. In 1884, the first salmon cannery in the Bristol Bay region was built by Arctic Packing Co., east of the site of modern-day Dillingham. Ten more canneries were established within the next seventeen years. The Dillingham town site was first surveyed in 1947. Dillingham was incorporated in 1963 and is a first class city.<sup>1</sup>

Commercial fishing, fish processing, cold storage, and support of the fishing industry are the primary regional economic activities, producing half of the world's sockeye salmon supply each summer. In 2018, the region saw a harvest of 152 million pounds of sockeye. After processing, this harvest was valued at \$688 million. Dillingham's role as the regional center for government and services helps to stabilize seasonal employment. Many residents depend on subsistence activities. Some residents trap beaver, otter, mink, lynx, and fox for supplemental income. Salmon, grayling, pike, moose, caribou, and berries are also locally harvested.

### 3.2 Location and Regional Setting

The City of Dillingham is located on the northwest shoreline of Wood River where it meets the Nushagak River at the far north end of Nushagak Bay in northern Bristol Bay (Figure 1). The city encompasses 33.6 sq. miles of land and 2.1 sq. miles of water. Dillingham is the transportation, economic, and public service hub for the Bristol Bay region and can only be reached by air or sea, making the airport and port vitally important for the livelihoods of Dillingham-area residents. Nearby communities, including New Stuyahok, King Salmon, Togiak, Koliganek, Ekwok, and Manokotak, regularly rely on Dillingham and DLG for meeting transportation and other public service needs. Dillingham's economy relies heavily on the commercial fishing industry and use of its ports and airport for the export of salmon and seafood from Bristol Bay.

---

<sup>1</sup> Alaska Community Database Online, DCRA, Accessed June 2020.

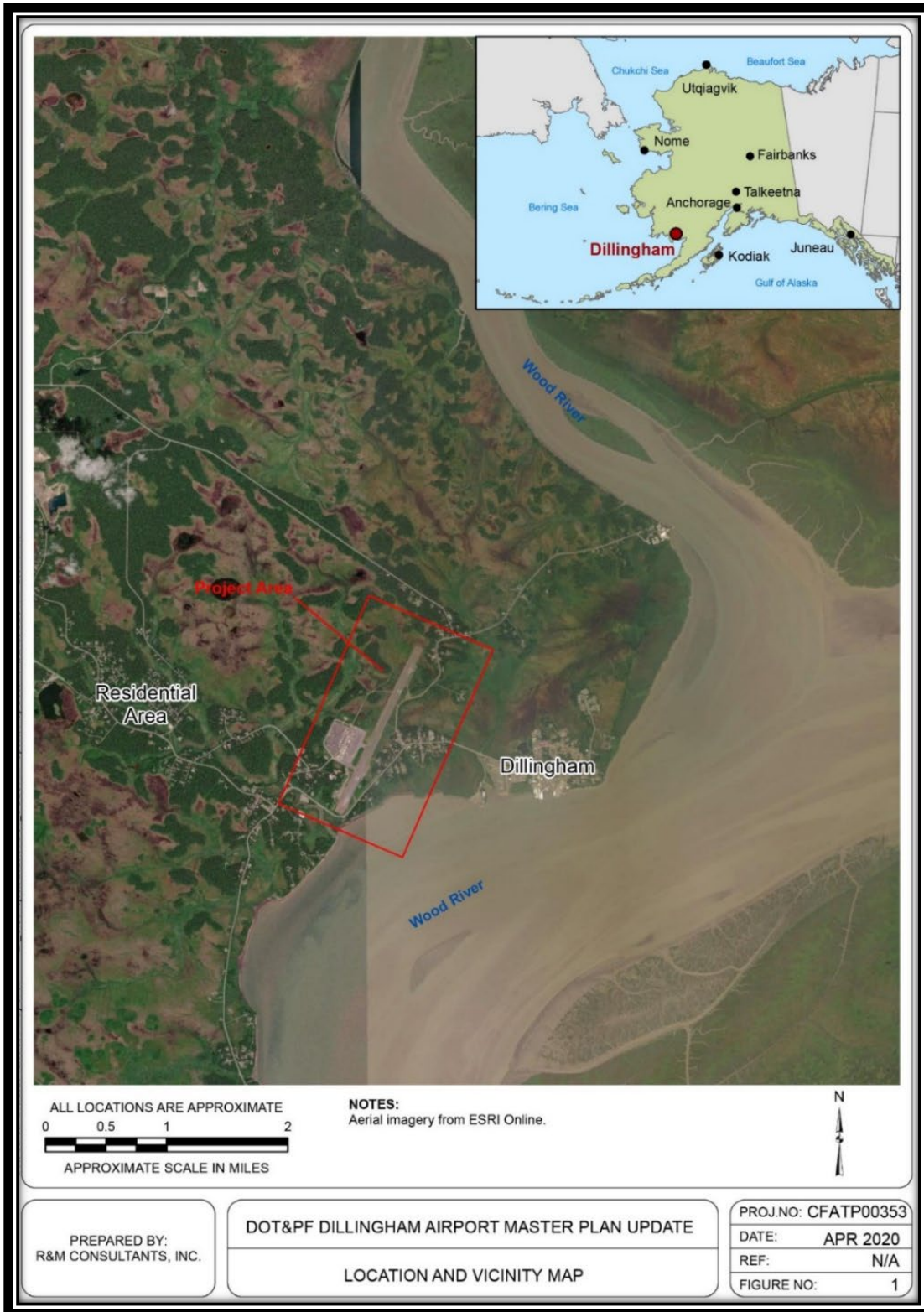

Figure 1: DLG Location & Vicinity Map

### 3.3 Dillingham Airport Background and History

DLG was built in the 1950s. Initial construction consisted of a 3,750-foot-long, gravel-surfaced runway and access road. Through the 1960s and 1970s, additional land was acquired, the runway was lengthened, and aprons, facilities, roads, and utilities were added. The runway was paved in 1980.

DLG sits on 635.36 acres of airport property owned by the Alaska Department of Transportation & Public Facilities (DOT&PF) Central Region.<sup>2</sup> DOT&PF leases land to air carriers and aviation-related businesses, which have made tenant improvements such as buildings, utilities, and parking areas.

An AMP was completed in 1985, with planned improvements including the Terminal Apron expansion and the gravel-surfaced general aviation apron being built on the west side of the airport. In 2005, another AMP was completed. Significant capital improvement projects, acquisitions, and assessments funded by the Airport Improvement Program (AIP) since the 2005 AMP include:

**Table 1: AIP Capital Improvements Since 2005 AMP<sup>3</sup>**

AIP Number	Capital Improvement	Obligated	Closed	Total Cost
3-02-0200-052-2005	Rehabilitate Runway 1-19 (Maintenance) (RE RW IM)	8/30/2005	6/9/2010	\$80,000
3-02-0200-055-2006	Acquire Snow Removal Equipment Deicer truck (4,000-gal) (ST EQ SN)	8/17/2006	7/9/2013	\$173,661
3-02-0200-056-2006	Rehabilitate Runway 1-19 (Maintenance) (RE RW IM)	6/30/2006	2/27/2012	\$89,633
3-02-0200-065-2008	Acquire Snow Removal Equipment; Acquire SRE: DLG—Tractor Truck for pull broom w/ attachments (ST EQ SN)	6/16/2008	2/5/2014	\$200,000
3-02-0078-011-2009	Construct Sand and Chemical Storage Building; Construct 3-Bay Sand and Chemical Storage Building (ST BD SN)	8/20/2009	3/10/2016	\$2,747,361
3-02-0200-069-2009	Rehabilitate Runway 1-19 (Various Surface Maintenance) (RE RW IM)	8/20/2009	12/19/2014	\$85,120
3-02-0200-071-2009	Acquire Snow Removal Equipment; Acquire SRE (Central Region): Snow Blower w/ attachments; Dozer w/ attachments	9/17/2009	10/28/2013	\$150,873
3-02-0200-072-2009	Acquire Safety and/or Security Equipment; Acquire Water Rescue Equipment (SA EQ RF)	9/24/2009	11/12/2014	\$67,145
3-02-0078-012-2010	Rehabilitate Apron (LOC) (RE AP IM); Rehabilitate Taxiway (LOC) (RE TW IM)	3/30/2010 3/30/2010	3/10/2015 3/10/2015	\$5,586,886 \$2,107,386
3-02-0200-073-2010	Rehabilitate Runway 1-19 (Various Surface Maintenance) (RE RW IM)	3/12/2010	12/9/2015	\$96,840
3-02-0078-013-2012	Construct Runway Safety Area 1-19 (SA RW SF)	8/29/2012	5/23/2017	\$17,183,668

<sup>2</sup> State of Alaska Department of Law Title Opinion, dated June 16, 2003.

<sup>3</sup> "Airport Improvement Program (AIP) FY 1982 – FY 2019", Federal Aviation Administration, Alaskan Region Airports Division.

AIP Number	Capital Improvement	Obligated	Closed	Total Cost
3-02-0200-085-2012	Wildlife Hazard Assessments (PL PL WH)	8/28/2012	10/12/2017	\$106,461
3-02-0078-014-2013	Construct Runway Safety Area 1-19, Phase 2 (SA RW SF)	7/30/2013	5/26/2017	\$2,004,615
3-02-0078-015-2013	Acquire Aircraft Rescue & Fire Fighting Vehicle (3,000-gal ARFF truck) (SQ EQ RF)	9/19/2013	3/29/2018	\$660,881
3-02-0200-093-2013	Rehabilitate Runway 1-19 (Surface Preservation Maintenance) (RE RW IM)	9/18/2013		\$180,600
3-02-0200-094-2013	Acquire Snow Removal Equipment; Acquire SRE (Runway Broom) (ST EQ SN)	9/19/2013	3/12/2018	\$448,026
3-02-0200-095-2014	Remove Obstructions (+08J) (SA OT OB)	9/22/2014		\$278,437
3-02-0200-097-2014	Acquire Snow Removal Equipment (+08J); Acquire SRE (Plow) (ST EQ SN)	9/19/2014		\$667,168
3-02-0200-098-2014	Rehabilitate Runway 1-19 (+08J) Various Surface Preservation Maintenance (RE RW IM)	9/19/2014		\$312,350
3-02-0078-016-2017	Rehabilitate Runway 1-19 (RE RW IM)	7/11/2017		\$9,572,170
3-02-0200-113-2017	Acquire Interactive Training System, Various 139 Airports (OT EQ MS)	9/21/2017		\$11,443
3-02-0200-118-2017	Rehabilitate Runway 1-19, Various Surface Preservation Maintenance; Re-marking Runway 1-19 and Taxiways A, B, and C, and Terminal Apron (RE RW IM)	9/21/2017		\$137,694
3-02-0078-017-2018	Update Airport Master Plan Study (PL PL MA)	8/2/2018		\$468,750
3-02-0078-018-2018	Install Perimeter Fencing required by 49 CFR 1542, Install fencing and access-controlled gates (SA EQ SE)	9/19/2018		\$2,864,074
3-02-0200-125-2019	Rehabilitate Runway 1-19, Various SPM, Taxiways A, B, and C, and Terminal Apron (RE RW IM)	9/27/2019		\$165,543

The Federal Aviation Administration (FAA) classifies Dillingham Airport within the National Plan of Integrated Airport System (NPIAS)<sup>4</sup> as a non-hub, primary commercial service airport, which is regulated under Title 14 Code of Federal Regulations (CFR) Part 139. A commercial service airport is a publicly-owned airport that receives scheduled passenger service and has at least 2,500 passenger boardings each year. Commercial service airports, like DLG, that enplane more than 10,000 annual passengers are primary airports. An airport is defined as an air traffic hub if it enplanes at least 0.05% of the passengers in the nation; if under 0.05%, the airport is non-hub.

<sup>4</sup> National Plan of Integrated Airport System (NPIAS), Federal Aviation Administration, Accessed June 2020, [https://www.faa.gov/airports/planning\\_capacity/npias/](https://www.faa.gov/airports/planning_capacity/npias/).

In Alaska, Part 139 certification is required for airports serving scheduled and unscheduled operations for aircraft with more than 30 passenger seats and scheduled operations for aircraft with more than 9 seats but less than 31 seats. Dillingham is classified as a regional airport by the Alaska Aviation System Plan (AASP) and is a Part 139 airport.<sup>5</sup> A regional airport supports regional economies by connecting communities to statewide and interstate markets.

As a Part 139, Category III airport, DLG is subject to airport security requirements and Transportation Security Administration (TSA) oversight under 49 CFR Part 1542 – Airport Security. Security requirements include perimeter fencing, terminal screening, and Airport Operations Area (AOA) and Security Identification Display Area (SIDA) badging.

### 3.4 Airport Role in the Community and Regional Infrastructure

With no roads in or out of the region and limited marine cargo service, DLG provides vital air passenger and cargo services to the region. Passenger travel and air freight are highly seasonal with commercial and sport fishing in the summer months, which places a large demand on services.

Air transportation between Dillingham and Anchorage and to surrounding villages is necessary for a variety of reasons, including medical appointments, meetings, business, education, sports, and visits to family and friends. The ability to fly between communities creates a network that allows the region to function and thrive.

Health care professionals at the regional hospital and the public health department recognize the essential service of medevac flights from surrounding villages to Dillingham and, if further medical attention is needed, from Dillingham to Anchorage. Air travel is vital to the connectivity of the region's health care system. With clinics in every village in the Bristol Bay Area Health Corporation service area, medical, behavioral health, and dental teams must travel by air to provide direct care. Air travel is also required for staff training and delivery of prescription drugs and medical equipment. Regional travel is provided by numerous small local carriers.

State and federal agencies, such as the Alaska State Troopers (AST), Department of Fish & Game (ADF&G), and the U.S. Fish and Wildlife Service (USFWS), fly extensively to carry out their mandates. AST, the principal law enforcement agency serving the region, and other agencies use local commercial operators extensively, although AST also operates their own aircraft stationed at DLG. Prisoners are transported by air from regional villages to Dillingham and Anchorage. ADF&G brings seasonal data technicians and freight into the region by air. Those technicians then fly out to remote rivers and lakes by floatplane to collect data used to manage the multi-million-dollar Bristol Bay sockeye salmon fishery. ADF&G also flies aerial surveys with fixed wing and rotary aircraft to count herring and salmon in regional bays, rivers, and lakes. The Togiak National Wildlife Refuge has a hangar at DLG; staff use their aircraft to conduct biological surveys, as well as patrol and visit local villages. Dillingham is also a bypass mail hub, serving the communities of Aleknagik, Clarks Point, Ekwok, Koliganek, Manokotak, New Stuyahok, and Twin Hills.<sup>6</sup>

---

<sup>5</sup> Alaska Aviation System Plan, State of Alaska Department of Transportation and Public Facilities, Accessed June 2020, [https://internal.alaskaasp.com/Facilities/Default.aspx?tab=general&id=51&siteid=50153.\\*A](https://internal.alaskaasp.com/Facilities/Default.aspx?tab=general&id=51&siteid=50153.*A).

<sup>6</sup> "Southwest Alaska Transportation Plan Update," Alaska Department of Transportation & Public Facilities, 2016.

## 4.0 Existing Conditions

This chapter describes existing airside and landside facilities serving the operational needs at DLG, as well as DLG's environmental context.



Figure 2: DLG Project Area

## 4.1 Airfield/Airspace

### 4.1.1 Airport Reference Code

The Airport Reference Code (ARC) for DLG is currently C-III, with the Boeing 737-700 as the critical aircraft. The FAA developed the ARC to determine airport design criteria based on the airport’s critical aircraft.<sup>7</sup> The ARC is composed of two elements, the Aircraft Approach Category (AAC) and the Airplane Design Group (ADG). AAC “C” indicates that the approach speed for DLG’s critical aircraft is 121-140 knots. ADG “III” indicates that the critical aircraft wingspan is 79-117 feet. See the DLG Aviation Forecast Report of this master plan for more information, including the forecasted ARC change to C-IV by 2040, with the Lockheed L- 100 as the critical aircraft.

### 4.1.2 Runways<sup>8</sup>

DLG has one paved runway used for all the airport’s aircraft operations, designated 1-19.

**Table 2: Runway 1-19**

<b>Runway</b>	1-19
<b>Dimensions</b>	6,400 ft. x 150 ft.
<b>Surface Type</b>	Grooved Asphalt
<b>Marking Type</b>	Non-Precision Instrument
<b>Marking Condition</b>	Good
<b>Runway End 01 Elevation</b>	76.6 ft.
<b>Runway End 19 Elevation</b>	65 ft.
<b>Approach Visibility Minimum</b>	1 Statute Mile
<b>Pavement Condition Index (PCI)</b>	99.34 <sup>9,10</sup>
<b>Pavement Class Number</b>	54/F/C/X/T <sup>11</sup>

The runway pavement load rating is as follows<sup>12</sup>:

**Table 3: Runway 1-19 Pavement Load Rating**

<b>Single Wheel</b>	116,000 pounds
<b>Double Wheel</b>	186,000 pounds
<b>Double Tandem</b>	300,000 pounds
<b>Dual Double Tandem</b>	726,000 pounds

<sup>7</sup> “Critical aircraft” is the most demanding aircraft (in terms of approach speed and wingspan) that conducts at least 500 annual operations at the airport (AC 150/5000-17).

<sup>8</sup> “Dillingham,” Alaska Aviation Information Directory, Alaska Department of Transportation & Public Facilities, accessed April 15, 2020.

<sup>9</sup> Alaska Airport Pavement Inspection Report, May 24, 2018.

<sup>10</sup> General pavement recommendation: 85-100 Do Nothing/Preventative Maintenance.

<sup>11</sup> The PCN is a five-part code that describes a piece of pavement. This code explains the pavement’s load-carrying capacity, whether it is rigid or flexible, the strength of the pavement’s subgrade, the maximum tire pressure that can be supported, and whether the first number of the code was determined using a technical evaluation or physical testing.

<sup>12</sup> “Dillingham,” Alaska Aviation Database, Alaska Aviation System Plan, Alaska Department of Transportation & Public Facilities, accessed April 15, 2020.



#### 4.1.3 Lighting, Approach Aids, and Nav aids<sup>13</sup>

Dillingham Airport has non-precision instrument (NPI) approaches. Both runways have RNAV (GPS) approaches. Additionally, Runway 01 also has a very high frequency omnidirectional Range (VOR) approach; and Runway 19 has a localizer approach. Visibility minimums one statute mile. Approach plates are printed in the Alaska U.S. Terminal Procedures Publication for the following four approach procedures<sup>14</sup>:

- RNAV (GPS) RWY 01
- RNAV (GPS) RWY 19
- LOC RWY 19
- VOR RWY 01

There are various visual and navigational aids (NAVAIDs) in place at the airport. NAVAIDs and equipment consist of: VOR, DME, non-directional beacon, rotating beacon, direction finding antenna, localizer, precision approach path indicator (PAPI), visual approach path indicator (VASI), wind cones/segmented circle, Stand Alone Weather Sensors (SAWS), Omni-Directional Approach Lights (ODALS), and an automated weather observing system (AWOS). There is an FAA flight service station at the airport.

**Table 4: Runway 1-19 Lighting & Approach Aids**

<b>Edge Intensity</b>	High
<b>Runway Mark Type Condition</b>	NPI-G/NPI-G
<b>Visual Glide Slope Indicator (VGSI)</b>	PAPI, RW 1 / VASI, RW 19
<b>Visual Glide Path Angle</b>	3/3
<b>Runway End Identifier Lights (REIL)</b>	YES, RW 19
<b>Approach Lights</b>	ODALS, RW 19

**Table 5: Runway 1-19 Nav aids**

Type	ID	Name	Frequency	Hours	Distance	Bearing
NDB	BTS	Wood River	429 MHz	24	3 nm	26°
VOR/DME	DLG	Dillingham	116.4 MHz	24	3.4 nm	25.5°

<sup>13</sup> "Dillingham," Alaska Aviation Database, Alaska Aviation System Plan, Alaska Department of Transportation & Public Facilities, accessed April 15, 2020.

<sup>14</sup> "DLG Dillingham," IFP Information Gateway Search, Federal Aviation Administration, Accessed June 8, 2021, [https://www.faa.gov/air\\_traffic/flight\\_info/aeronav/procedures/application/?event=procedure.results&nasId=DLG#searchResultsTop](https://www.faa.gov/air_traffic/flight_info/aeronav/procedures/application/?event=procedure.results&nasId=DLG#searchResultsTop).



Figure 3: ODALS North of RW 19



Figure 4: ODALS North of RW 19, Close-up



**Figure 5: Localizer South of RW 01**

#### 4.1.4 Obstruction Data<sup>15</sup>

Table 6 provides obstruction information at DLG.

---

<sup>15</sup> "Dillingham," 5010 Airport Master Record, FAA, accessed April 15, 2020.

**Table 6: Runway 1-19 Obstacles**

<b>FAR 77 Category</b>	<b>C/C</b>
<b>Controlling Obstacle</b>	Trees
<b>Height Above Runway End</b>	85'
<b>Distance from Runway End</b>	1,700'
<b>Obstruction Clearance Slope</b>	50:1 / 17:1

#### 4.1.5 Aprons<sup>16</sup>

DLG has two aprons for aircraft parking: The Terminal Apron and the General Aviation (GA) Apron.

**Table 7: DLG Aprons**

Apron Name	Dimensions	PCI	General Pavement Recommendation
<b>Terminal Apron</b>	1,700 ft. x 470 ft.	90	85-100 Do Nothing/Preventative Maintenance <sup>17</sup>
<b>GA Apron</b>	1,300 ft. x 430 ft.	N/A	N/A, unpaved (recycled asphalt surfaced) <sup>18</sup>

Lease lots east of Airport Road extend approximately 200 feet over the Terminal Apron. All aircraft access RW 1-19 via the Terminal Apron. This includes GA aircraft, since Taxiway C connects the GA Apron to the Terminal Apron.

The east edge of the Terminal Apron, between taxiways A and B, is used as a large aircraft parking area. Transient aircraft, such as corporate jets, use the north end of the Terminal Apron for parking, with space at the northwest corner generally reserved for medevac aircraft. Aircraft parking space at the north end often fills up during the busiest part of the summer, and additional transient aircraft must then park along the east edge of the Terminal Apron.

The GA Apron is located west of Airport Road and has hangars along the east and west edges. 74 tie-downs are noted. The south end of the GA Apron is available for transient GA aircraft, and there is a section east of Block 700 noted for summer transient parking.<sup>19</sup> Tie-downs can be added to meet demand and are removed in the winter for snow clearing. See “4.3 General Aviation Facilities” below for more information.

#### 4.1.6 Taxiways<sup>20</sup>

Runway 1-19 is accessible from the Terminal Apron by taxiways A and B. Taxiway C provides access from the GA Apron to the Terminal Apron. DLG does not have a full-length parallel taxiway. Consequently, it is often necessary for airplanes to taxi a long distance on the runway and turn around before taking off on Runway 19 and after landing on Runway 01, which delays operations during busy times and increases the potential for runway incursions. Runway 1-19 also does not meet line-of-sight requirements, and alternatives for addressing this should be evaluated.

<sup>16</sup> DLG Airport Layout Plan (2023).

<sup>17</sup> Alaska Airport Pavement Inspection Report, May 24, 2018.

<sup>18</sup> Ibid.

<sup>19</sup> Dillingham Airport Land Occupancy, September 26, 2019.

<sup>20</sup> DLG Airport Layout Plan (2023).

**Table 8: DLG Taxiways**

Taxiway Name	Dimensions	PCI	General Pavement Recommendation
<b>Taxiway A</b>	515 ft. x 90 ft.	93.02	85-100 Do Nothing/Preventative Maintenance <sup>21</sup>
<b>Taxiway B</b>	515 ft. x 90 ft.	96.82	85-100 Do Nothing/Preventative Maintenance <sup>22</sup>
<b>Taxiway C</b>	1,750 ft. x 50 ft.	82.00	70-84 Preventative Maintenance <sup>23</sup>

#### 4.1.7 Services/Navcom<sup>24</sup>

Table 9 provides information on various services available at DLG.

**Table 9: DLG Aeronautical Services & Facilities**

Services	
<b>Fuel Type</b>	100LLA
<b>Air Frame Repair</b>	Minor
<b>Power Plant Repair</b>	Minor
<b>Bottled Oxygen Type</b>	None
<b>Bulk Oxygen Type</b>	None
<b>Transient Storage</b>	Tie-Down
<b>Other Service</b>	Cargo
Facilities	
<b>UNICOM Frequencies</b>	N/A
<b>Wind Indicator</b>	Yes
<b>Segmented Circle</b>	Yes
<b>Control Tower</b>	N/A
<b>Tie-In FSS</b>	Yes
<b>Tie-In FSS Name</b>	Dillingham
<b>Airport to FSS Phone Number</b>	907-842-5275
<b>Tie-In FSS Toll Free Number</b>	907-842-5275
FSS Attendance Schedule	
<b>Months</b>	All
<b>Days</b>	All
<b>Hours</b>	0800-1830

## 4.2 Commercial Passenger Terminal Facilities

There is currently no joint-use terminal building used by all carriers; however, the Alaska Airlines/Ravn Alaska terminal building is used for most of the commercial passenger service at DLG. Other carriers utilize their own facilities, as available.

<sup>21</sup> Alaska Airport Pavement Inspection Report, May 24, 2018.

<sup>22</sup> Ibid.

<sup>23</sup> Ibid.

<sup>24</sup> "Dillingham," Alaska Aviation Database, Alaska Aviation System Plan, Alaska Department of Transportation & Public Facilities, accessed April 15, 2020.



Figure 6: Alaska Airlines/Ravn Air Terminal Building Exterior

There is a single gate and baggage claim area at the Alaska Airlines/Ravn Alaska terminal building. The ticketing area has five kiosks. The waiting area is not physically separated from the gate for security purposes, although TSA personnel are present. There are no restaurants, concession areas, or vending machines at the airport. Restroom facilities are unreliable and inadequately sized to meet needs during the busier summer months.



Figure 7: Baggage Claim Area, Alaska Airlines/Ravn Air Terminal Building



Figure 8: Ticketing Area, Alaska Airlines/Ravn Air Terminal Building



Figure 9: Waiting Area, Alaska Airlines/Ravn Air Terminal Building



### 4.3 General Aviation Facilities

Table 10 shows the documented number and types of based aircraft, all of which use the GA Apron. Around June, tie-downs can become fully occupied, creating the need to stake additional tie-downs.

#### Based Aircraft<sup>25</sup>

Table 10: DLG Based Aircraft (2020)

Aircraft Type	Count
Single Engine GA	52
Multi Engine GA	6
Jet Engine GA	N/A
Helicopters GA	1
Gliders Operational	N/A
Military Operational	N/A
Ultralights	N/A

There are 11 lease lots directly abutting the GA Apron, seven on the west end and four on the east end. Hangars and buildings are maintained by their respective tenants and are in various states of repair.

Electrical service at the GA Apron is available at the perimeter lease lots. Interior tie downs do not have electricity access, and many pilots bring their own generators. Maintenance staff have shared concerns that expanding electricity access to the interior of the GA Apron would make winter maintenance more difficult.

#### Flight Schools

Approximately five years ago, more formalized flight instruction was available. While this is no longer the case, there are generally still one or two pilots who offer instruction at any given time.

#### Aircraft Maintenance Facilities

Air carriers with hangars at DLG have access to licensed aviation mechanics to service their aircraft, who may be onsite or flown in. Those mechanics may also provide contract maintenance services for other air carriers and pilots, depending on whether the mechanic is licensed as part of the air carrier or as an individual.

There are currently no independent aircraft maintenance facilities at DLG. While there have been some freelance mechanics who provide onsite aircraft maintenance services from their vehicles, those services are intermittent. Stakeholder comments indicated that there could be sufficient demand for an independent aviation mechanic to establish a business there.

---

<sup>25</sup> "Dillingham," Alaska Aviation Database, Alaska Aviation System Plan, Alaska Department of Transportation & Public Facilities, accessed April 15, 2020.

## 4.4 Cargo Facilities

There are three primary facilities that handle cargo movement at DLG:

1. Alaska Cargo Services, used primarily by Northern Air Cargo, Lynden Air Cargo, and Ryan Air
2. Alaska Pride Air, used primarily by ACE Air Cargo and Everts Air Cargo
3. Alaska Airlines, used primarily by Alaska Air Cargo

Each facility abuts the Terminal Apron for ease of access to RW 1-19. See the Aviation Activity section below for information about cargo operations.



Figure 10: Freight Delivery at DLG

## 4.5 Support Facilities

See Appendix A: Airport Layout Plan for detailed facility locations.

### **Flight Service Station (FSS)**

DLG is a non-towered airport and uses a Flight Service Station (FSS). Since the 2005 AMP update, the FSS was relocated from the Grant Aviation Building to northwest of the Terminal Apron, next to the transient aircraft parking area. The FSS is staffed by FAA personnel who are responsible for weather and airport condition reporting, airport traffic advisories, emergency services to aircraft in distress, aeronautical notice dissemination, search and rescue notifications, and flight planning assistance. The FSS also has remotely operated weather cameras that provide real-time pictures of the airport. FSS hours of operation are 0800 to 1830 every day.



Figure 11: Flight Service Station

### **Aircraft Rescue and Fire Fighting (ARFF) and Airport Maintenance**

DOT&PF operates and maintains DLG. The combined ARFF and Snow Removal Equipment Building (SREB) is located directly south of Taxiway C, between the access road and GA apron. This building has six bays and also houses DOT&PF's administrative space.



Figure 12: ARFF/SERB

DOT&PF's combined maintenance garage and chemical storage building is located west of the ARFF/SREB and south of Taxiway C. The sand storage building is located south of the chemical storage building.

**Fuel Storage**

Table 11 shows each airport tenant’s fuel storage at DLG, broken out by fuel type and amount.

**Table 11: Fuel Storage at DLG**

Company	Container Size (Gal)	Fuel Type
<b>Alaska Airlines</b>	1000	Heating Oil
<b>Alaska Cargo Services</b>	2000	Avgas 100LL Double Wall
	5000	Jet-A Mobile
	500	Heating Oil
	3000	Jet-A Mobile
	4000	Jet-A Mobile
<b>Alaska Island Air</b>	240	Avgas 100LL Mobile
	55	Heating Oil
<b>Alaska Pride Air</b>	2000	Heating Oil
	5000	Avgas 100LL Fireguard
	100	Unleaded Fuel
	200	Heating Oil
<b>Antler Aviation and Wildlife Services</b>	500	Avgas 100LL Mobile
<b>Bay Air</b>	500	Heating Oil
<b>Bristol Bay Air</b>	500	Avgas 100LL Mobile
	55	Heating Oil
<b>DOT&amp;PF</b>	4000	Diesel Fuel Fireguard
	2000	Diesel Fuel Fireguard
	2000	Heating Fuel Fireguard
	1000	Heating Oil Double Wall
	3000	Heating Oil Double Wall
<b>FAA</b>	2000	Heating Oil
<b>Freshwater Adventures</b>	2000	Avgas 100LL Fireguard
	1100	Heating Fuel
	300	Heating Oil
<b>Grant Aviation Hangar</b>	1000	Heating Oil
	2800	Jet-A Mobile
<b>Mulchatna Air</b>	2000	Avgas 100LL Fireguard
	1000	Heating Oil
<b>Seventh Day Adventists</b>	220	Heating Oil
<b>Shannons Air Taxi</b>	500	Avgas 100LL Mobile
	300	Heating Oil
<b>Starflite Air</b>	1500	Heating Oil
	2000	Jet-A Mobile
<b>Togiak National Wildlife Refuge</b>	1000	Avgas 100LL
	550	Heating Fuel
<b>Tucker Aviation</b>	1000	Avgas 100LL Mobile
	500	Heating Oil
	500	Unleaded Fuel
<b>Van Air</b>	500	Avgas 100LL

## 4.6 Access, Circulation, and Parking

Dillingham Airport is located approximately four miles from Dillingham’s city center, near the junctions of Kanakanak Road, Aleknagik Lake Road, and Wood River Road. Kanakanak Road provides primary access to the airport property.

Within airport boundaries, all airport terminal and tenant access is provided via Airport Road and West Airport Road. West Airport Road goes around the west side of the GA Apron, connecting to North Airport Boundary Road to provide access to two residences northwest of DLG.

The strip of land east of Airport Road, adjacent to the buildings by the Terminal Apron, has been identified as a parking area. This parking strip is an earth and gravel area that lies between the various buildings and Airport Road. Tenants, employees, and patrons park adjacent to the various buildings whenever space is available.

Separate vehicle parking for general aviation is not available. Pilots park personal vehicles in the airplane’s tie-down spot while flying. The long-term parking area is approximately 0.3 miles southwest from the Alaska Airlines/Ravn Air terminal building. Two overhead lights have been added since the previous Airport Master Plan update, but the area is otherwise unsecured. Several junk vehicles have been abandoned in the long-term parking lot. While DOT&PF requires vehicle owners to move their vehicles from the long-term parking after 30 days, enforcement remains a challenge. Removing the abandoned vehicles would improve the security and operability of the parking lot.



Figure 13: Long Term Parking Lot at DLG

### Car Rental Service

Beaver Creek Auto Rentals (1.7 miles from DLG) and D&J Rentals (two miles from DLG) provide car rental service. Both provide pick-up and drop-off service at the airport. There may be demand for rental vehicles at the airport, if protected space were available.

## 4.7 Utilities

The following section discusses the range of available utilities at DLG.

### **Water**

While the City of Dillingham has a community water system that draws ground water, there are no municipal water system hook-ups extended to DLG. Tenants are responsible for providing water to their lease lots by drilling wells or storing water in tanks. The State of Alaska Department of Natural Resources' (DNR) Well Log Tracking System (WELTS) notes the presence of three wells on DLG property<sup>26</sup>:

- USDI Fish & Wildlife Services: 100-foot well below ground surface
- Southwest Air: 80-foot well below ground surface
- Yute: 60-foot well below ground surface

Aeronautical survey and planimetric field survey data from previous years provided greater well location specificity than Alaska DNR's WELTS map; it is assumed that the surveys provide more reliable location data. The 2020 DLG Land Occupancy figures indicate an additional well location between the maintenance garage and sand storage facility, with water lines connecting to fire hydrants.

### **Sanitary Sewer**

DLG has access to the City of Dillingham's wastewater service via an underground connection to the east of Runway 1-19. The sewer line is pressurized between the pump station at DLG and a catch basin at the east end of Runway 1-19. There is a gravity line extending southwest from the pump station parallel to Airport Road.

### **Heating Fuel**

DLG tenants generally use heating oil furnaces and have heating oil tanks on their lease lots. DOT&PF uses heating oil in all buildings with the exception of the electrical equipment building, which uses a small electric heater.

Natural gas is not supplied to DLG.

### **Electric & Communications**

Nushagak Electric & Telephone Cooperative provides electricity, telephone, and internet service to DLG. The connections to DLG originate from an underground line east of Runway 1-19. The electric line extends west beyond Airport Road, encompassing the north and most of the west perimeter of the GA Apron, and roughly parallel to Airport Road to provide connections for lease lots. The telecom line extends to the northwest corner of the Terminal Apron then runs southwest along Airport Road.

The Flight Service Station (FSS) and ARFF/SREB building also have a backup generator available.

### **Stormwater Drainage**

A storm drain, culverts, and ditches facilitate stormwater drainage at DLG. The storm drain and catch basins run parallel to Airport Road on the east side. The first intake is at the driveway between

---

<sup>26</sup> "Well Log Tracking System (WELTS)," Alaska Department of Natural Resources, Division of Mining Land & Water, Accessed April 30, 2021, <https://dnr.alaska.gov/welts/#show-welts-intro-template>.

Freshwater Adventures and Alaska Airlines, with water running north and draining into a ditch from an open outfall at the north side of Taxiway C.

Culverts are placed throughout DLG property, including beneath RW 1-19, Taxiways A and B, and the various vehicle accesses.

### **Deicing**

DOT&PF personnel provide deicing services, although some commercial carriers deice their own aircraft. Liquid urea and solid potassium acetate pellets are used in deicing.

### **Waste Disposal**

Facility trash is emptied when full into on-site dumpsters. The dumpsters are serviced weekly by Dillingham Waste Management. Oil pads used to clean oil spills are either burned or thrown in the trash, once dry.

Used batteries and light bulbs are stored inside within labeled plastic containers and disposed of at the local landfill once per year. Used battery containers are labeled with an accumulation start date. State Equipment Fleet staff remove and replace all vehicle and equipment batteries, recycling them if possible.

Used aerosol cans were determined by the United States Environmental Protection Agency (EPA) to be a universal waste as of December 2020. Since DLG is a Very Small Quantity Generator under the Resource Conservation and Recovery Act (RCRA), its empty aerosol cans can be treated as household hazardous waste instead. As such, they are stored in a labeled container (no accumulation start date required) and are taken to the local landfill once per year, when the landfill accepts household hazardous waste.

Solvents are not stored at DLG. There is a separate SEF facility off-site that does all the vehicle maintenance and has a solvent tank for cleaning tools and parts.

Human waste facilities are connected to the sewer line at DLG, which is part of the City of Dillingham domestic wastewater sewer system. Wastewater in the ARFF/SREF building, warm storage building, and chemical storage building passes through oil-water separators. The oil-water separators are cleaned out annually, and waste is taken to an approved disposal facility. Water from the oil-water separators is connected to the City of Dillingham domestic waste water sewer system. Sewage and wastewater are treated at the Dillingham Wastewater Treatment System.

Used oil from vehicle maintenance is burned by the SEF facility in their used oil burner.

Road and airfield paint utilized at the airport is waterborne. The paint is stored in plastic disposable totes. Once empty, the totes are crushed and disposed of at the landfill. Previously, DOT&PF had a contract with a paint manufacturer that provided storage totes for paint recycling.

## **4.8 Recycling and Solid Waste Minimization**

The DLG Stormwater Pollution Prevention Plan (SWPPP) details recycling activities and best management practices. At DLG, used vehicle and equipment batteries are recycled by SEF.

The Dillingham Landfill recycles aluminum cans, electronics, fluorescent bulbs, glass, refrigerators and freezers, scrap metal and appliances, tires, and vehicles. The feasibility of solid waste recycling for DLG beyond what is available at the Dillingham Landfill is limited due to the small community size as well as the distance and lack of a road connection to larger recycling facilities.

To minimize solid waste generation, DOT&PF staff break down, flatten, and/or crush urea bags, empty boxes, and empty, dry paint totes. Staff also reuse some metal paint tote cages for crack sealant and paint gun strainer bags.

#### 4.9 Land Ownership and Use

DLG property is entirely within the Dillingham city limits. DOT&PF owns the DLG property and maintains jurisdiction over its operations. A large proportion of the developable land in the City of Dillingham that is accessible by road is held as Native allotments. Other major landowners include Choggiung Limited, the City of Dillingham, and the State of Alaska (Figure 14).

DLG is located near Dillingham's three major roads: Kakanak Road, Wood River Road, and Aleknagik Lake Road. Kakanak Road crosses airport property south and southeast of the runway, and a portion of Wood River Road enters airport property southeast of the runway and north of Kakanak Road. These road corridors contain the majority of Dillingham's residential development. The airport property is surrounded by residential development on all sides except the northeast.

The locations of existing residential properties and the Evergreen Cemetery present possible land use conflicts with airport property. Two residents are located adjacent to the northwest airport property boundary. Access to the residential property is from Airport Road connecting to West Airport Road and North Airport Road, around the general aviation (GA) apron. This may result in difficult public access control along these roads and on airport property. Additionally, a residence encroaches onto airport property east of the runway, north of Kakanak Road.

The Evergreen Cemetery is located east of the runway on a knoll above the runway elevation, fully within airport property boundaries. The cemetery is still in use. It encroaches on the east side of the Runway Safety Area (RSA) which, according to FAA standards, should be cleared around the airfield. Both the adjacent residential uses and the culturally sensitive Evergreen Cemetery may affect the safe operation of the airport or limit its expansion.



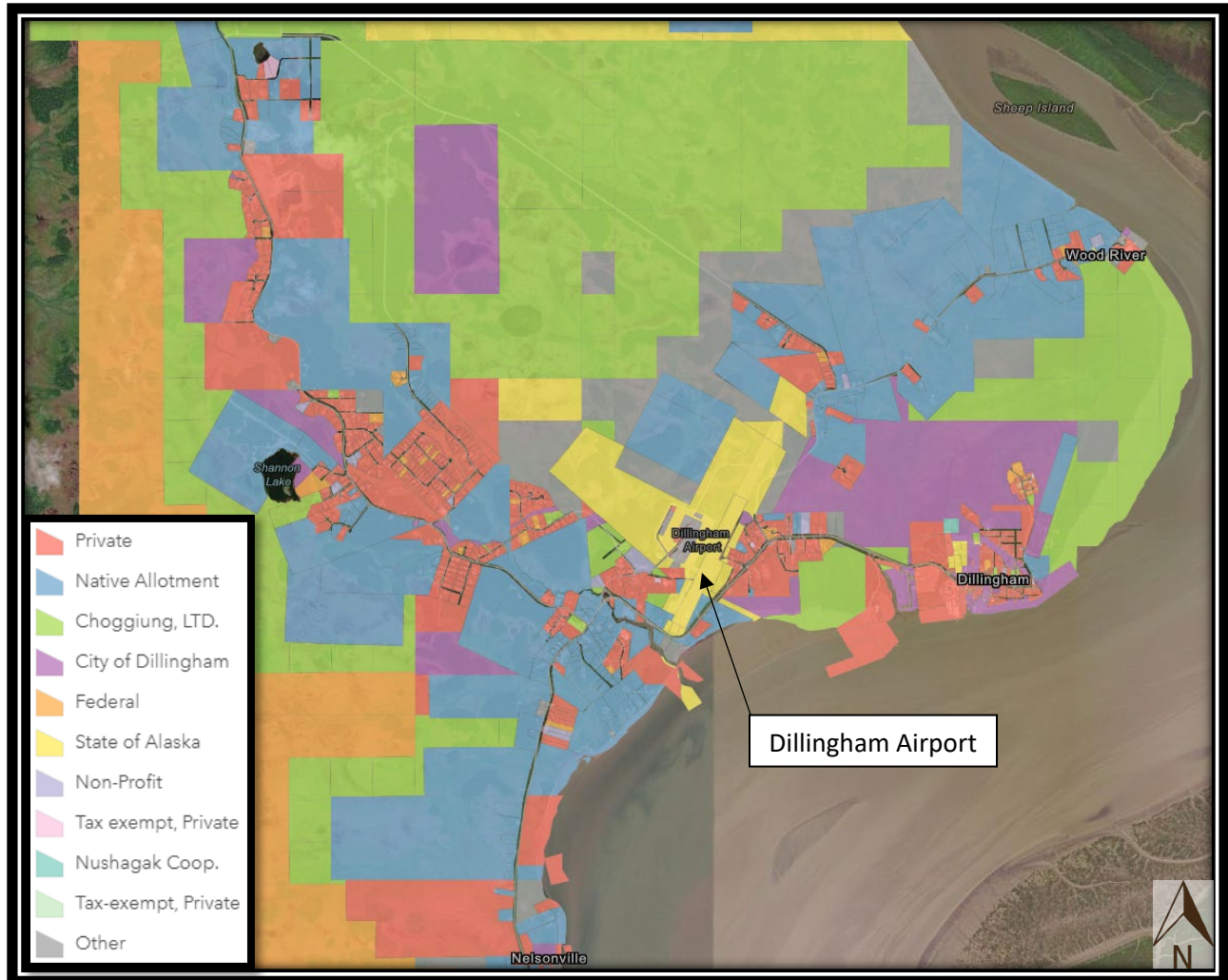

**Figure 14: City of Dillingham Land Ownership Map. Source: City of Dillingham Parcels (2021 GIS)**

Airport land uses can be classified as either aeronautical (uses directly related to or involved with the operation of aircraft) or non-aeronautical. Non-aeronautical land uses are any airport land use, business, service, or function that is not involved with or directly related to the operation of aircraft. Almost all current land uses on DLG are aeronautical uses, with only the Evergreen Cemetery, long-term parking lot, and an area along the northeast edge of the airport boundary designated as non-aeronautical. The Twin Dragon restaurant (previously hosted on a lot leased by private air operator Grant Aviation, Inc.) was another aeronautical use, but it closed in July 2021. Airport access roads, current lease lot tenants, and airport facilities all are directly for transportation activities, or support aeronautical activities.

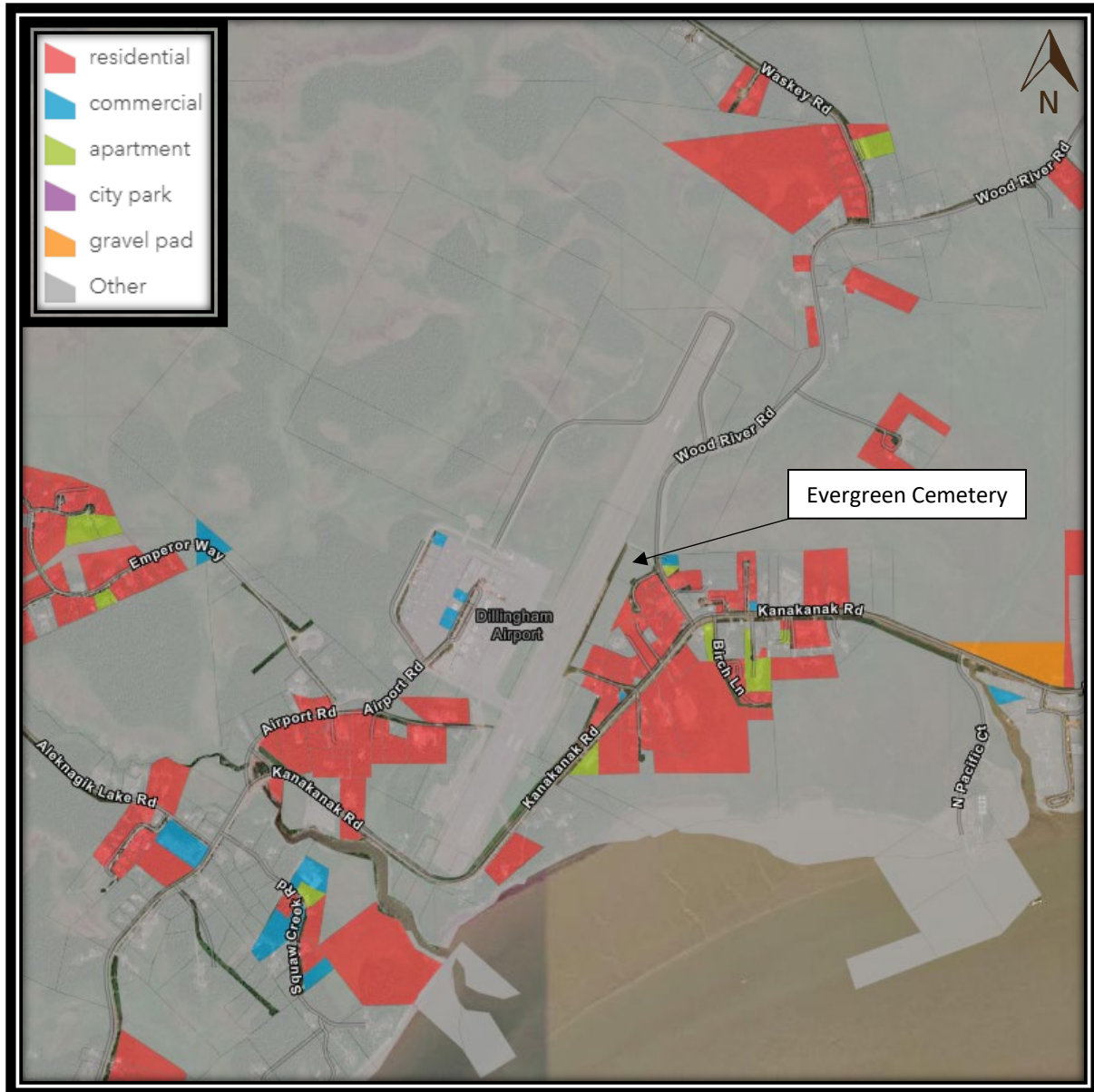

Figure 15: Current Land Use Near DLG. Source: City of Dillingham Parcels (2021 GIS)

#### 4.9.1 Airport Layout Plan (2016)

The 2016 Airport Layout Plan (ALP) includes a Land Use Plan which has been used to inform this Master Plan and the updated ALP. The Land Use Plan designates areas on and adjacent to airport property for uses based on the ultimate layout identified in the ALP. Aeronautical use areas include aviation use, revenue support, aviation hazard easement, and aviation reserve. Non-aeronautical use areas include non-aviation, commercial mixed use, residential, and no airport interest.

Aviation use areas contain aeronautical facilities and support facilities, including the runway, runway protection zones (RPZs), terminal apron, taxiways, and general aviation apron. Aviation hazard easements are identified south of Runway 1-19 within and around the south RPZs, south of Kanakanak Road, and east of the runway where the Evergreen Cemetery is located. The Land Use Plan recommends

acquisition of property north of the Runway 19 end for RPZ protection, expanding airport property and aviation use area, to contain the existing RPZ within airport property, and to accommodate the ultimate runway length and location. All existing lease lots at DLG are within revenue support designated areas.

A significant portion of DLG property is designated as aviation reserve. This area is west of the building restriction line, GA Apron, and existing lease lots. Aviation reserve areas intend to protect or preserve airport land for future expansion of aviation facilities. Based on the orientation and shape of the airport property boundary and the aviation reserve area in the 2016 ALP Land Use Plan, it is assumed the area was reserved for the potential addition of a crosswind runway; however, the ultimate layout does not include a crosswind runway or any aviation facility expansion into this area. Previous versions of the ALP do show the ultimate development of a crosswind runway in this area. A review of available wind data from 2011 to 2020 supports a crosswind runway sized to accommodate category A-I and B-I aircraft (Table 12). The main runway does not achieve 95% coverage for the allowable crosswind component (10.5 knots) for small aircraft.

**Table 12: Wind Data**

RW	Crosswind Component:	10.5 kt	13 kt	16 kt
	<b>RDC:</b>	A-I/B-I	A-II/B-II	A-III/B-III/C-I through D-III
<b>11/29</b>	ALL WEATHER	90.86%	95.07%	98.26%
<b>11/29</b>	IFR	91.72%	95.45%	98.50%
<b>11/29</b>	VFR	90.57%	94.92%	98.19%

There is a small area south of the General Aviation Apron and west of Airport Road that is categorized for non-aviation revenue. A portion of that area is currently being used as a vehicle parking lot. A second non-aviation revenue area is identified east of Runway 1-19 and west of the existing airport fence and building restriction line that is accessible from Wood River Road. Beyond airport boundaries, the Land Use Plan identifies the commercial mixed-use area where Dillingham residents live and work.

#### 4.9.2 City of Dillingham Land Use Planning

The City of Dillingham Comprehensive Plan was adopted in 2010. It serves as the guiding document for future land development and management in Dillingham, according to community-defined needs and interests. It includes a Land Use Designation Map that outlines the locations of current uses, the general expectations about locations of future development, and includes eight general land use designations (Figure 16).

DLG is classified as “Public Lands and Institutions”, which includes airports. Land surrounding DLG primarily has the Residential Focus designation. This permits low-density, residential use with options for home-based and other businesses compatible with a predominately residential area. Additionally, an area southwest of the northern half of the DLG runway is identified as Commercial Mixed Use on the Land Use Designation Map. This district allows commercial and retail services, with an option for secondary uses including residential. Both the residential and commercial mixed uses reflect a continuation of the current pattern of residential uses adjacent to the DLG property boundary.

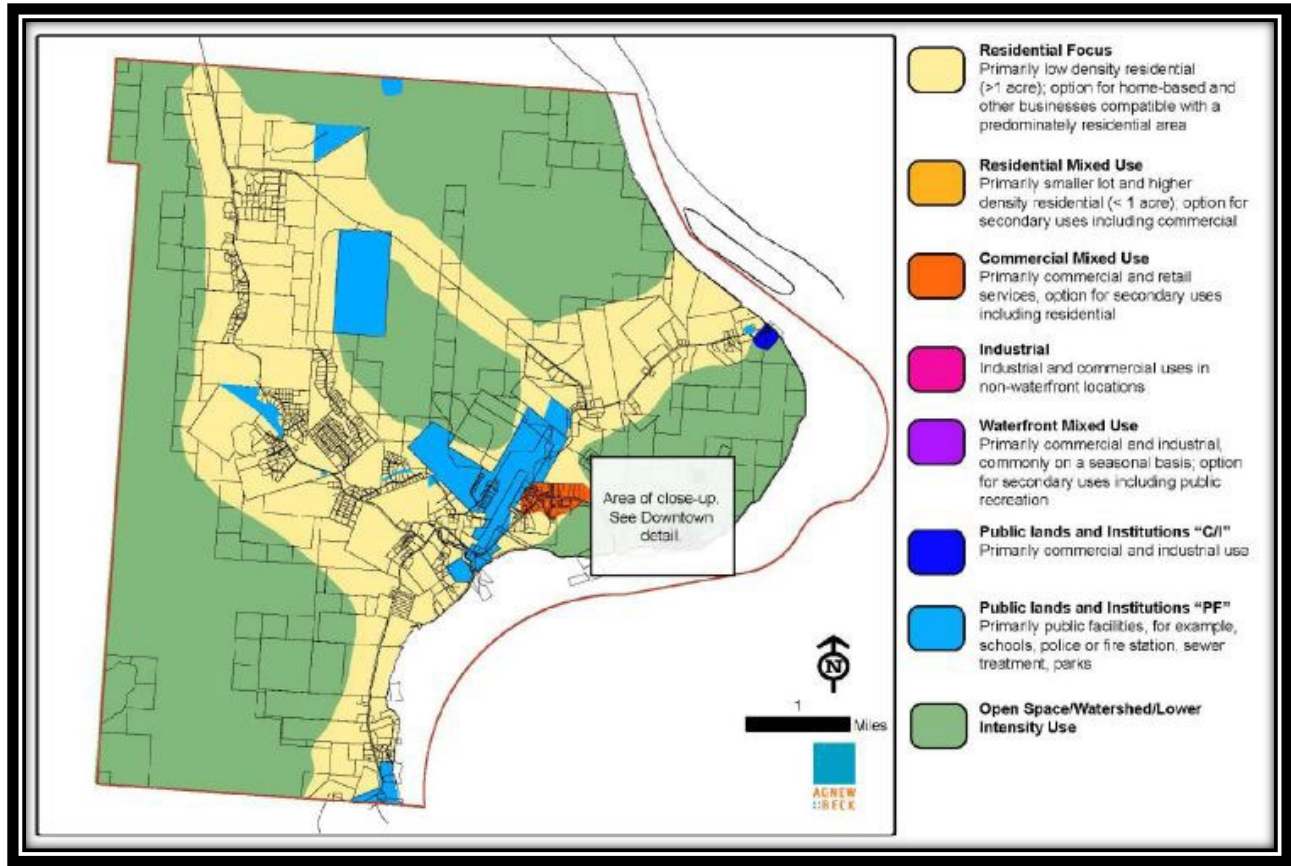

Figure 16: Land Use Designations, City of Dillingham Comprehensive Plan (2010)

#### 4.10 Environmental Conditions

The environmental section provides an overview of environmental conditions at DLG, potential environmental impacts of airport development alternatives, and probable permitting requirements.

The Dillingham area occupies outwash plains, low moraines, a few choppy moraine hills, and many muskegs, lakes, and streams. Rolling terraces and moraines primarily have white spruce, paper birch, or black spruce trees and contain well-drained soils without permafrost. The soil consists of silty volcanic ash over very gravelly glacial drift. Slight depressions with sedges and mosses typically have very poorly drained fibrous organic soils with permafrost. Swales in terraces and moraines contain poorly drained silty soils with permafrost. Beneath a thick, peaty mat is mottled gray silt loam. The vegetation associated with this soil is primarily tussocks, mosses, low shrubs, and scattered patches of black spruce.

The following resource categories were considered for the airport property and nearby surrounding parcels. The current aquatic and terrestrial conditions of these categories are described based on available public data and documents.

#### 4.10.1 Aquatic Conditions

##### **Air Quality**

Air quality is not monitored in Dillingham, and DLG is not in a non-attainment or maintenance area for air quality. Note that common air quality issues in rural communities are from dust (PM<sub>10</sub>) due to the number of unpaved roads and driveways, and wood smoke (PM<sub>2.5</sub>) from home heating. There are a number of unpaved roads and driveways in the area around DLG increasing PM<sub>10</sub> pollution after snow has melted.

##### **Anadromous/Resident Fish Streams**

Squaw Creek runs southwest of DLG and is an anadromous stream supporting chinook, chum, coho, pink, and sockeye salmon; and rainbow smelt. The Nushagak River runs south of DLG and is an anadromous stream supporting chinook, chum, coho, pink, and sockeye salmon, Arctic char, and whitefish.

##### **Floodplain and Regulatory Floodway [Executive Order 11988]**

The FEMA Flood Map Service Center was consulted for floodplain data; however, no digital data is available for the two flood maps containing DLG (0200410016B & 0200410017B). The U.S. Army Corps of Engineers Floodplain Mapping did not show the presence of a floodplain near DLG.

##### **Habitat-Endangered/Threatened Aquatic Species**

Endangered aquatic species with ranges including the area around Dillingham are the blue whale, fin whale, gray whale, humpback whale, Northern Pacific right whale, and sei whale. Ringed seals are the only listed threatened aquatic species.

##### **Navigable Waters**

Nushagak River is navigable from the mouth of the river to the village of Koliganek. Wood River is navigable for 24 miles starting from the mouth.

##### **Water Quality**

DLG is not connected to the City of Dillingham's community water system. The DNR's Well Log Tracking System notes three wells at DLG: a 100-foot well (U.S. Fish and Wildlife Services), an 80-foot well (Yute), and a 60-foot well (Southwest Air). Water quality data for these wells is not available.

Several drinking water protection area (DWPA) zones originating from wells outside of DLG property are shown overlapping DLG property (Figure 17 and Table 13). Spills and other sources of pollutants originating at DLG could affect water quality within these protection areas.

The Statewide PFAS site reported that ADEC collected ten samples from drinking water wells within and adjacent to DLG property and detected perfluoroalkyl and poly-fluoroalkyl substances (PFAS). Perooctanesulfonic acid, perfluorooctanoic acid, and perfluorobutane sulfonate were detected in groundwater at the Holy Rosary Church public water system (AK2263018) at a combined concentration of 185.5 ng/L, but the other sites did not indicate concentrations above DEC action levels.

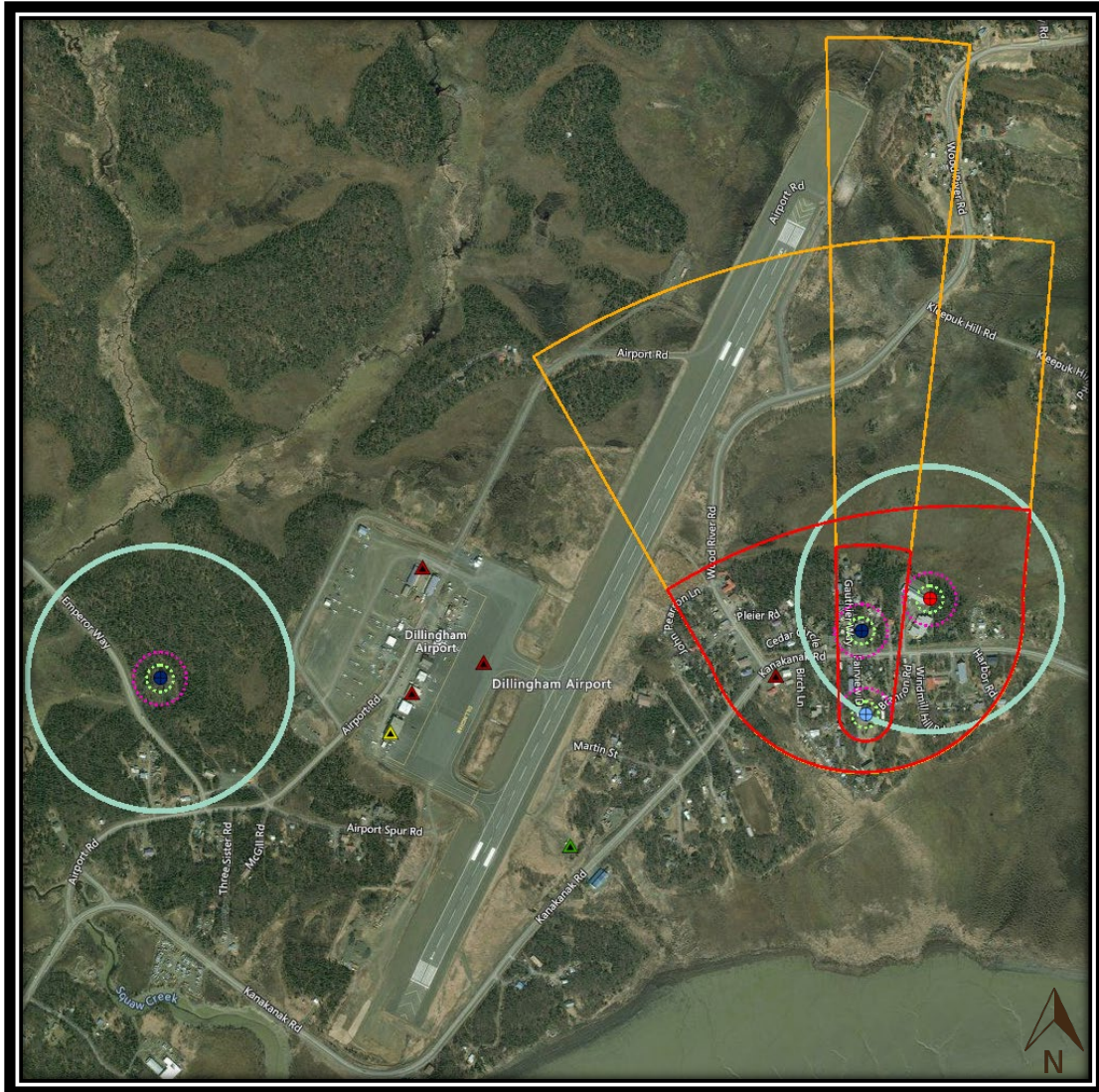

Figure 17: ADEC Drinking Water Protection Area Mapper

Table 13: Drinking Water Protection Area Mapper Legend

Map Object	Notes	Symbol
Community Water System	N/A	
Non-Transient Non-Community Water System	N/A	
Non-Community Water System	N/A	
Zone A	Groundwater: Several months' time-of-travel; or immediate watershed	
Zone B	Groundwater: Two years' time-of-travel; adjacent watershed	
Provisional	Temporary Drinking Water Protection Area in place until full delineation can be completed. 1,000-foot radius around public water system source.	

**Wetlands**

The USFWS National Wetlands Inventory indicates the presence of extensive wetlands at DLG and the surrounding area (Figure 18). The primary wetland and riparian types are freshwater forested/shrub wetland, freshwater emergent wetland, and riverine.



Figure 18: National Wetlands Inventory Map

4.10.2 Terrestrial Conditions

**Contaminated Areas**

The ADEC Contaminated Sites Database<sup>27</sup> shows contaminated sites on DLG property (Table 14 and Figure 19).

<sup>27</sup> <https://dec.alaska.gov/spar/csp/>.

Table 14: DLG Contaminated Sites & Status





Site Name	Site Status	Symbol
ADOT&PF Dillingham Airport Maintenance Facility	Active	
ADOT&PF Dillingham Airport Sitewide PFAS	Active	
PenAir Hangar - Dillingham	Active	
Yute Air Terminal Dillingham	Cleanup Complete – Institutional Controls	



Figure 19: DLG Contaminated Areas Map



The ADEC Division of Spill Prevention and Response’s PPR SPILLS Database lists recorded spills at DLG. Recent spills and their status are shown in Table 15.

**Table 15: DLG Recorded Spills**

Spill Number	Spill Name	Spill Date	Facility Name	Status
19269918602	Dillingham Airstrip 5gal aviation gas	7/5/19	DLG on Tarmac	Case Closed, No Further Action
19269902801	Bristol Alliance Fuels 5-10gal LL Aviation Fuel	1/28/19	DLG	Case Closed, No Further Action
17269902801	16gal hydraulic spill DOT Dillingham Airport	1/28/17	DLG on Tarmac	Case Closed, No Further Action

**Terrestrial and Avian Habitat-Endangered/Threatened Species:**

Endangered avian species with ranges including Dillingham are the Steller’s eider, short-tailed albatross, and Kittlitz’s murrelet. No terrestrial species are listed.

**Invasive Species [EO 13751]**

There are no documented invasive species in the vicinity of DLG.

**Migratory Birds and Eagle Nests:**

Bald eagles are noted as a bird of concern in Dillingham. They are not endangered but are protected by the Bald and Golden Eagle Protection Act and state regulations. If bald eagle nests are detected within the primary (330 feet) or secondary (660 feet) protection zones stated in the 2007 Bald Eagle Management Guidelines, clearing guidelines should be followed. USFWS recommends avoiding clearing at DLG between March 1 and August 31 for eagles, and land disturbance and vegetation clearing in forested, woodland, shrub and open areas should be avoided between May 1 and July 15. The window for seabird colonies is May 10 to September 15. USFWS supplements this by noting that raptors may nest two or more months earlier than other birds, Canada geese and swans begin nesting April 20, and black scoter may nest through August 10.

4.10.3 Cultural Considerations

**Historic Properties, Archaeological and Cultural Resources:**

There are no known historic properties or archaeological or cultural resources on DLG property. The Evergreen Cemetery is located within the OFA. Project alternatives must address potential impacts to the Evergreen Cemetery.

**State Refuges, National Wildlife Refuges, and Sanctuaries:**

There are no state refuges, national wildlife refuges, or sanctuaries in the vicinity of DLG.

4.11 Socioeconomic Conditions

Dillingham airport largely serves residents in the Dillingham Census Area, and the wider regions of Bristol Bay Borough and Lake and Peninsula Borough.

#### 4.11.1 Population

Ten communities are in the Dillingham Census Area totaling 4,887 residents in 2019. Population has been stable in recent years, fluctuating between approximately 4,850 and 5,060 residents since the 2010 census. The largest community is Dillingham (population: 2,327), followed by Togiak (873), Manokotak (483), and New Stuyahok (476), and Aleknagik (208). Clark’s Point, Ekwok, Koliganek, Portage Creek, and Twin Hills each have populations under 200.

In 2019, the Bristol Bay Borough, located southeast of DLG, was home to 869 residents. Current population levels are about 15% lower than the peak of 1,023 residents in 2011. Out of the three communities, the largest is Naknek (488), followed by King Salmon (301) and South Naknek (80).

The Lake and Peninsula Borough, located south and east of DLG, has also seen relatively stable population levels over the past decade. The 2019 population of 1,622 is comparable to the 2010 census of 1,631 residents. The largest of the 18 communities is Port Alsworth (226), followed by Newhalen (211), and Levelok (157).

**Table 16: Population Counts, Dillingham Census Area, Bristol Bay Borough, and Lake and Peninsula Borough, 2010-2019<sup>28</sup>**

Year	Dillingham Census Area	Bristol Bay Borough	Lake and Peninsula Borough
2010	4,847	997	1,631
2011	4,935	1,023	1,677
2012	4,978	983	1,679
2013	5,025	933	1,700
2014	5,063	943	1,687
2015	5,008	887	1,676
2016	4,958	875	1,642
2017	4,925	892	1,724
2018	5,007	877	1,658
2019	4,887	869	1,622

Population in the Dillingham Census Area has trended higher since the 1970s. Current population levels are slightly lower than the peak observed in 2000 at about 5,000 residents.

After formation of the Bristol Bay Borough in 1962 (the state’s first borough), the 1970 census recorded 1,147 residents. Population of 1,410 residents in 1990 represented the peak; by 2010, the population had fallen by 29% (997 residents).

Population in the Lake and Peninsula Borough peaked in 2000 at 1,823 residents before declining about 11% to 1,631 in 2010.

<sup>28</sup> Alaska Department of Labor and Workforce Development

**Table 17: Population Counts, Dillingham Census Area, Bristol Bay Borough, and Lake and Peninsula Borough, by 1960-2010 Census Year<sup>29</sup>**

Census Year	Dillingham Census Area	Bristol Bay Borough	Lake and Peninsula Borough
1970	3,892	1,147	n/a
1980	3,232	1,094	1,384
1990	4,012	1,410	1,668
2000	4,922	1,258	1,823
2010	4,847	997	1,631

#### 4.11.2 Demographics

The majority of residents of Dillingham Census Area and Lake and Peninsula Borough identify as American Indian/Alaska Native alone or in combination with other races (78.5% and 71.6%, respectively), followed by White alone or in combination with other races (23.3% and 27.9%, respectively). The majority of residents in the Bristol Bay Borough identify as white alone or in combination with other races (63.7%), followed by American Indian / Alaska Native (41.3%).

**Table 18: Population by Race, Dillingham Census Area, Bristol Bay Borough, and Lake and Peninsula Borough, Percent of Population, 2014-2018 5-Year Estimates<sup>30</sup>**

Race (Alone or in Combination)	Dillingham Census Area	Bristol Bay Borough	Lake and Peninsula Borough
<b>American Indian or Alaska Native</b>	78.5	41.3	71.6
<b>White</b>	23.3	63.7	27.9
<b>Asian</b>	2.3	1.6	4.4
<b>Black or African American</b>	2.0	0.9	0.7
<b>Native Hawaiian or Pacific Islander</b>	0.4	0.7	1.5
<b>Some Other Race</b>	0.7	0.9	0.1

In Dillingham Census Area, about 27% of the population are under age 15 (2019); this portion of the population is similar in the Lake and Peninsula Borough (26%). In Bristol Bay Borough, residents under age 15 represented 17% of the population. Dillingham Census Area and Lake and Peninsula Borough population age 65 and older represented 10% and 11%, respectively. In Bristol Bay, residents age 65 and older made up 14.2% of the population.

<sup>29</sup> Alaska Department of Labor and Workforce Development.

<sup>30</sup> Alaska Department of Labor and Workforce Development.

**Table 19: Population by Age Cohort, Dillingham Census Area, Bristol Bay Borough, and Lake and Peninsula Borough, 2019<sup>31</sup>**

Age	Dillingham Census Area	Bristol Bay Borough	Lake and Peninsula Borough
0-4	9.1%	6.6%	9.6%
5-9	9.7%	5.8%	8.2%
10-14	8.5%	4.5%	7.8%
15-19	6.9%	6.4%	6.4%
20-24	6.8%	4.7%	5.7%
25-29	8.4%	6.8%	7.4%
30-34	6.6%	8.2%	8.3%
35-39	6.2%	5.3%	7.6%
40-44	4.0%	4.8%	5.3%
45-49	4.5%	6.6%	3.6%
50-54	5.8%	4.7%	5.5%
55-59	6.7%	10.8%	7.6%
60-64	6.8%	10.8%	6.6%
65-69	4.2%	6.8%	5.1%
70-74	2.2%	2.8%	2.2%
75-79	1.8%	2.4%	1.4%
80-84	1.1%	1.3%	1.1%
85-89	0.4%	0.7%	0.6%
90+	0.2%	0.1%	0.1%

Males make up most of the population in Dillingham Census Area (51.7%), Bristol Bay Borough (59.1%), and Lake and Peninsula Borough (51.6%).

**Table 20: Current Population by Sex, Dillingham Census Area, Bristol Bay Borough, and Lake and Peninsula Borough, 2014-2018 5-Year Estimates<sup>32</sup>**

Sex	Dillingham Census Area	Bristol Bay Borough	Lake and Peninsula Borough
Male	51.7%	59.1%	51.6%
Female	48.3%	40.9%	48.4%

The median annual household income was \$58,750 in Dillingham Census Area, \$84,688 in Bristol Bay Borough, and \$46,406 in Lake and Peninsula Borough. Persons living below the poverty level represented 17.2% of the Dillingham Census Area population, 5.8% of the Bristol Bay Borough population, and 15.9% of the Lake and Peninsula Borough population.

<sup>31</sup> Alaska Department of Labor and Workforce Development.

<sup>32</sup> Alaska Department of Labor and Workforce Development.

**Table 21: Income and Poverty, Dillingham Census Area, Bristol Bay Borough, and Lake and Peninsula Borough, 2014-2018 5-Year Estimates<sup>33</sup>**

Income/Poverty Indicator	Dillingham Census Area	Bristol Bay Borough	Lake and Peninsula Borough
<b>Median Household Income:</b>	\$58,750	\$84,688	\$46,406
<b>Mean Household Income</b>	\$72,873	\$99,525	\$60,837
<b>Median Family Income:</b>	\$59,519	\$98,475	\$48,984
<b>Mean Family Income</b>	\$75,930	\$105,765	\$66,199
<b>Persons Below Poverty (% of population)</b>	17.2%	5.8%	15.9%

#### 4.11.3 Employment and Economy

Dillingham Census Area had an annual average of 2,600 jobs in 2018. Employment in Bristol Bay Borough totaled 1,314 jobs, and 1,004 jobs in Lake and Peninsula Borough.<sup>34</sup> The economic base of the region is highly seasonal and predominantly driven by the harvest and processing of Bristol Bay salmon. Employment rises in the summer, often ten times larger than in the winter, driven primarily by fishing. Other summer seasonal employment includes construction, mineral exploration, and other activities.

The City of Dillingham is the center of economic, transportation, government, public and social services in the area.

The public sector is a key employer for the region, accounting for about 29% in Dillingham Census Area, 17% of employment in Bristol Bay Borough, and 44% in Lake and Peninsula Borough. Local government is the largest component of the region’s public sector, followed by state and federal employment.

Educational and health services is another key sector. While sector data are withheld for Bristol Bay Borough and Lake and Peninsula Borough (due to confidentiality concerns), the sector contributes nearly a quarter of total employment in the Dillingham Census Area. Employment in the sector includes a variety of outpatient, nursing and residential care, and social assistance organizations with Kakanak Hospital in Dillingham (operated by the Bristol Bay Area Health Corporation) supporting most employment.

Retail businesses serve residents year-round or seasonally in the summer to support the busy summer months. Of the three regions, retail employment in the Dillingham Census Area is the highest at 201 jobs.

The region’s leisure and hospitality sector is composed primarily of accommodations, restaurants, and bars. In addition to businesses located in hub communities of Dillingham or King Salmon, the sector includes employment at sport fishing lodges.

A variety of other sectors contribute to employment in the region, including professional & business services, transportation & warehousing, financial activities, and information, among others.

<sup>33</sup> Alaska Department of Labor and Workforce Development.

<sup>34</sup> These employment figures do not include the self-employed, such as fishermen.

**Table 22: Employment by Sector in Number of Jobs, Dillingham Census Area, Bristol Bay Borough, and Lake and Peninsula Borough, 2018<sup>35</sup>**

	Dillingham Census Area	Bristol Bay Borough	Lake and Peninsula Borough
Educational & Health Services	628	*	*
Local Government	620	158	394
Retail	201	*	30
Leisure & Hospitality	92	120	123
State Government	85	24	6
Transportation & Warehousing	74	85	118
Federal Government	44	46	44
Professional & Business Services	29	28	10
Construction	*	*	38
Other	1,455	853	241
<b>Total</b>	<b>2,600</b>	<b>1,314</b>	<b>1,004</b>

\* indicates withheld data.

#### 4.11.4 Commercial Fishing Activity

In the Dillingham Census Area, resident commercial permit holders have fluctuated slightly between 2012 and 2019 (high of 621 in 2012 and a low of 595 in 2015). Active permits (number of permit holders who fished) ranged between 407 (2016) and 419 (2014).

In the Bristol Bay Borough, resident commercial permit holder levels are stable (fluctuating between 148 and 157) between 2012 and 2018; active permits ranged from 126 (2017) and 142 (2014).

In the Lake and Peninsula Borough, the number of resident commercial permit holders has fallen from 140 in 2012 to 121 in 2018; active permits also fell from 114 in 2012 to 72 in 2018.

<sup>35</sup> Alaska Department of Labor and Workforce Development.

**Table 23: Residents' Commercial Fishing Participation and Earnings, Dillingham Census Area, Bristol Bay Borough, and Lake and Peninsula Borough, 2012-2018<sup>36</sup>**

	Number of Permit Holders	Number of Permit Holders that Fished	Estimated Gross Earnings (\$million) <sup>37</sup>
<b>Dillingham Census Area</b>			
2012	615	412	\$13.7
2013	621	418	\$16.0
2014	609	419	\$20.3
2015	595	411	\$10.9
2016	600	407	\$20.1
2017	599	415	\$28.8
2018	604	416	\$33.3
<b>Bristol Bay Borough</b>			
2012	155	128	\$6.1
2013	157	137	\$5.8
2014	154	142	\$10.8
2015	153	141	\$5.4
2016	154	138	\$6.8
2017	152	126	\$8.3
2018	148	131	\$9.7
<b>Lake and Peninsula Borough</b>			
2012	140	114	\$12.7
2013	135	108	\$19.6
2014	124	104	\$9.3
2015	126	106	\$8.3
2016	124	104	\$10.5
2017	129	112	\$14.3
2018	121	72	\$5.0

In the Dillingham Census Area, there are three onshore fish processing facilities and several floating facilities east of Dillingham in Nushagak Bay and several more near Togiak and in different locations within the Bristol Bay Borough and the Lake and Peninsula Borough.

## 5.0 Aviation Activity Forecast

This chapter presents the DLG aviation activity forecast. It includes a discussion of historical aviation activity, factors affecting aviation activity, scenarios of forecasted aviation activity, and the forecasted critical aircraft.

<sup>36</sup> Commercial Fisheries Entry Commission.

<sup>37</sup> Italicized values exclude confidential data.

The demographic and economic data that influenced this forecast were discussed in Chapter 4. Discussion of data in Chapter 5 will focus on data sources not previously covered—primarily aviation activity.

### 5.1 Forecast Results Summary

The results of the forecasting efforts indicate a reasonable likelihood that DLG’s critical aircraft will be the Lockheed L-100 by 2040, with an Aircraft Approach Category (AAC) of C and an Airplane Design Group (ADG) of IV.

This would be a change from DLG’s current critical aircraft, the Boeing 737-700, with an AAC of C and an ADG of III. This result will be discussed later in the report.

**Table 24: Current and Ultimate Critical Aircraft**

Current Critical Aircraft	Current Airport Reference Code	Ultimate Critical Aircraft	Ultimate Airport Reference Code
Boeing 737-700	C-III	Lockheed L-100	C-IV

Historical data used in this forecast generally go through the end of 2019. This ensures consistency and accounts for the lack of full calendar-year data for 2020. Additionally, COVID-19 has significantly affected passenger data in 2020, which could problematically affect forecasts, given that COVID-19 impacts to passenger counts are expected to be more significant in the near-term. Until additional data regarding long-term impacts becomes available, COVID-19 impacts will be discussed but not forecasted.

### 5.2 Aviation Activity

The following sections present a review of past aviation activity, forecast methodology, and discussion of the factors that could affect future aviation activity at DLG. Forecasts for passengers, cargo, based aircraft, air taxi operations, general aviation operations, military aircraft operations, and the Airport Reference Code are presented.

The base year (year at which the most recent actual data was available) for forecasting is 2019. Forecasts were prepared for three future milestones: short term (2025), intermediate term (2030), and long term (2040).

#### 5.2.1 General Aviation and Military Operations

The FAA publishes a forecast of aviation activity for U.S. airports called the Terminal Area Forecast. The TAF dataset for DLG shows that 10,986 general aviation operations and 11 military operations occurred in 2019; however, some caution should be exercised in use of these data. The primary purpose of the TAF is to establish and predict budget and manning levels for the Air Traffic Organization (ATO), which is primarily related to towered airports. Forecasts are less detailed at airports with fewer than 100,000 annual enplanements, and DLG is a non-towered airport with fewer than 100,000 enplanements. Additionally, the general aviation and military operation counts have remained the same since 2007 and are held constant in future years. As such, the TAF will not be useful for forecasting these two types of operations.



### 5.2.2 Air Cargo

This section discusses historic freight and mail volumes at DLG. Table 25 and Figure 20 show reported freight volumes at DLG from 2010 to 2019.

**Table 25: DLG Total Freight Summary, 2010-2019<sup>38</sup>**

Year	Incoming Freight (lbs)	Outgoing Freight (lbs)	Total Freight (lbs)	Annual Growth Rate (Total Freight)
2010	4,745,483	2,767,641	7,513,124	-1.16%
2011	4,493,532	2,575,301	7,068,833	-5.91%
2012	4,956,858	2,305,322	7,262,180	2.74%
2013	3,900,444	1,708,634	5,609,078	-22.76%
2014	4,083,998	1,806,429	5,890,427	5.02%
2015	4,563,703	1,875,775	6,439,478	9.32%
2016	4,737,613	3,249,587	7,987,200	24.03%
2017	4,674,299	4,873,522	9,547,821	19.54%
2018	5,705,768	5,917,863	11,623,631	21.74%
2019	4,971,298	6,621,529	11,592,827	-0.27%

**Figure 20: DLG Total Freight Summary, 2010-2019<sup>39</sup>**

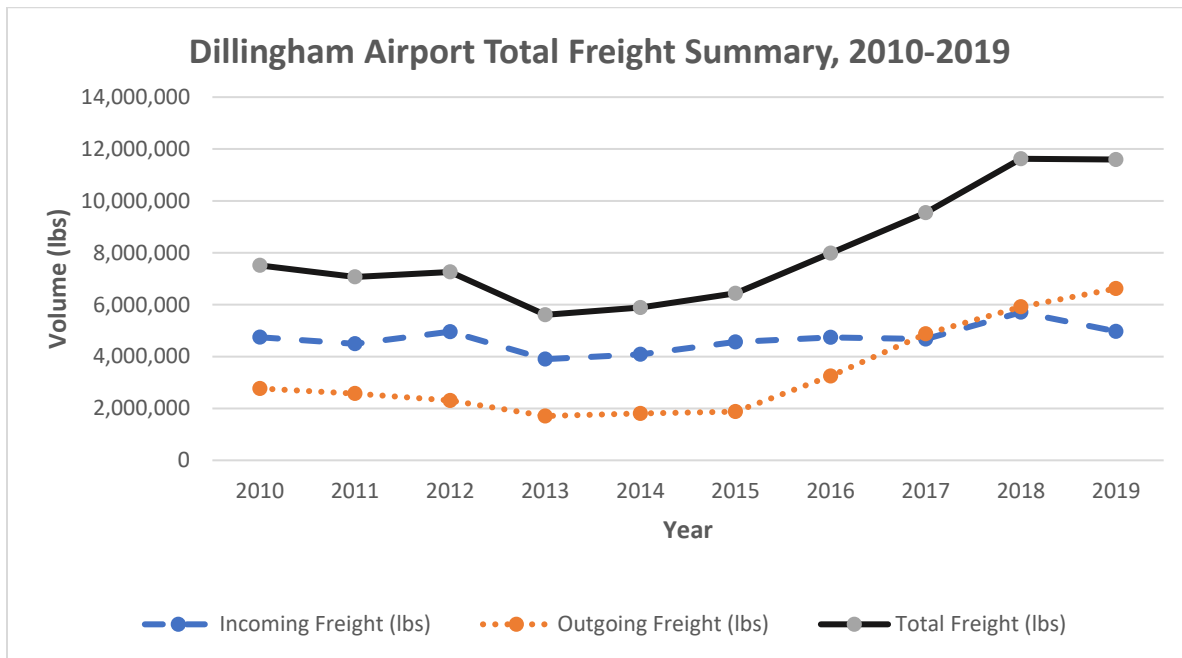

Following a period of weak or negative reported growth rates for freight volumes from 2010 to 2013, volumes increased significantly afterward, with the period between 2016 and 2018 showing the largest

<sup>38</sup> Bureau of Transportation Statistics: T-100 Domestic Segment, 2010-2019.

<sup>39</sup> Ibid.

total volume increases. The primary explanatory factor for the decline earlier in the decade is the Great Recession that followed the 2008 Financial Crisis.

Additionally, while incoming freight volumes were higher than outgoing volumes between 2010 and 2016, outgoing freight volumes overtook incoming volumes between 2017 and 2019. This will be discussed further in the forecasting section. Table 26 and Figure 21 show reported mail volumes at DLG from 2010 to 2019.

**Table 26: DLG Total Mail Summary, 2010-2019<sup>40</sup>**

Year	Incoming Mail (lbs)	Outgoing Mail (lbs)	Total Mail (lbs)	Annual Growth Rate (Total Mail)
2010	10,386,140	4,897,602	15,283,742	
2011	10,247,455	4,788,984	15,036,439	-1.62%
2012	9,566,878	4,613,736	14,180,614	-5.69%
2013	8,882,915	3,283,851	12,166,766	-14.20%
2014	8,417,643	3,095,770	11,513,413	-5.37%
2015	6,980,673	2,520,837	9,501,510	-17.47%
2016	6,995,187	2,296,618	9,291,805	-2.21%
2017	6,829,089	2,091,092	8,920,181	-4.00%
2018	6,596,812	2,076,023	8,672,835	-2.77%
2019	6,528,939	2,091,860	8,620,799	-0.60%

**Figure 21: DLG Total Mail Summary, 2010-2019<sup>41</sup>**

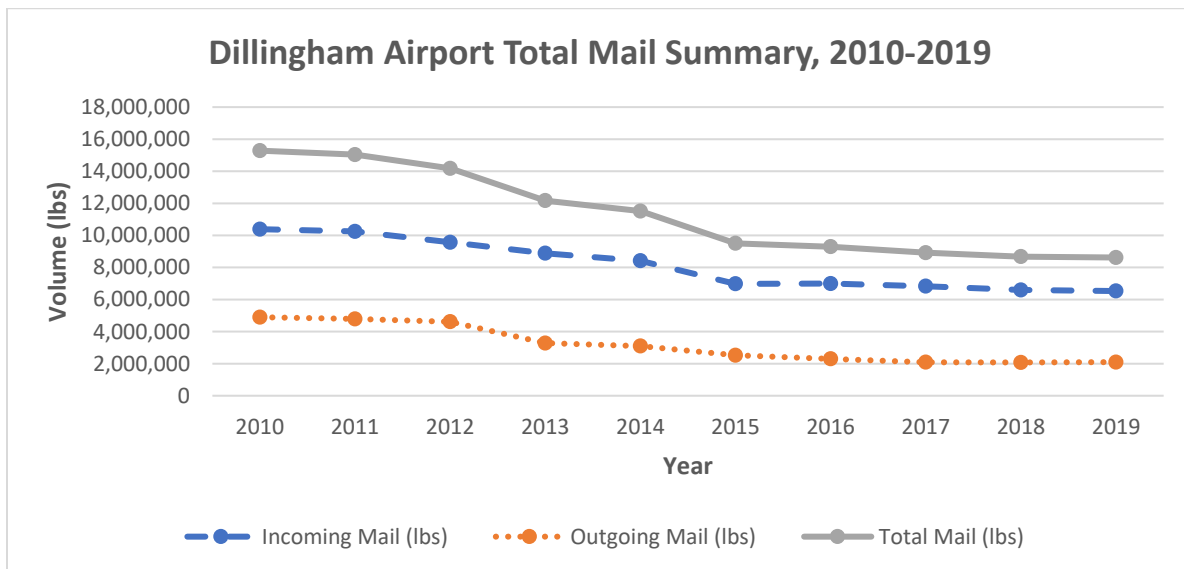

Reported mail volumes have continued to decrease annually from the period between 2010 to 2018, with 2015 and 2017 experiencing the largest annual decreases (-14.20% and -17.47% respectively).

<sup>40</sup> Bureau of Transportation Statistics: T-100 Domestic Segment, 2010-2019.

<sup>41</sup> Ibid.

### 5.2.3 Passenger Volumes

This section discusses the historical passenger volumes at DLG reported by T-100 filers. Table 27 and Figure 22 show reported commercial passenger levels at DLG from 2010 to 2019. Reliability of this data source is affected by the fact that passenger activity is not consistently reported by all air carriers; passenger volumes may be higher than are reported in the T-100 dataset.

**Table 27: Passenger Levels at DLG, 2010-2019<sup>42</sup>**

Year	Incoming Passengers	Outgoing Passengers	Total Passengers	Annual Growth Rate (Total Passengers)
2010	35,788	35,419	71,207	
2011	34,936	34,078	69,014	-3.08%
2012	32,549	32,195	64,744	-6.19%
2013	30,223	29,784	60,007	-7.32%
2014	31,314	31,142	62,456	4.08%
2015	30,147	30,003	60,150	-3.69%
2016	33,076	32,568	65,644	9.13%
2017	34,396	33,931	68,327	4.09%
2018	39,223	36,345	75,568	10.60%
2019	40,277	39,822	80,099	6.00%

**Figure 22: Total Passengers at DLG, 2010-2019<sup>43</sup>**

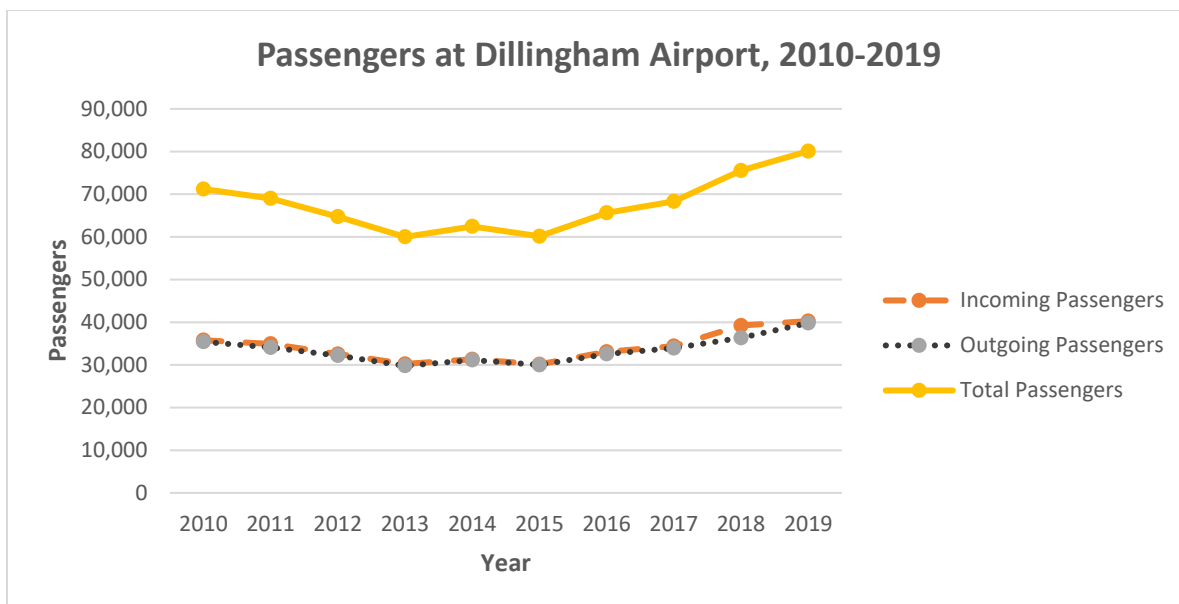

<sup>42</sup> Bureau of Transportation Statistics: T-100 Domestic Segment, 2010-2019.

<sup>43</sup> Ibid.

Following a period of declining reported passenger activity from 2010 to 2013 and 2014 to 2015, the total reported passengers have continued to increase for the period between 2015 and 2019, with the most significant annual growth in 2018 (10.60%).

#### 5.2.4 Factors Affecting Activity

Interviews were conducted with air carriers that either lease airport land at DLG or conduct operations at DLG. The data collected from interviews inform the aviation activity forecasts.

26 air carriers that conduct passenger, freight, and/or mail operations at DLG were contacted, of which 20 responded. They provided complete information to questions regarding recent or anticipated fleet changes for DLG operations, frequency of operations at DLG during the day and at night, preliminary comments about a potential runway shift to address Runway Safety Area (RSA) requirements, and contact information for future public and stakeholder involvement efforts.

Analysis of interview data yielded insight regarding key factors that have affected aviation activity and helped inform either the aviation activity forecasts or discussion of the results:

- COVID-19 had a significant negative impact on carriers that relied on providing passenger service because communities across the state were “hunkering down” to reduce the spread of the virus.
- There was generally less of an impact from COVID-19 for freight carriers. Some freight carriers even mentioned becoming busier after COVID-related restrictions were imposed.
- Northern Air Cargo is one of the largest cargo carriers in the state. The company revealed that they were considering switching to Boeing 737-800s for future DLG operations. This aircraft is more demanding than DLG’s current critical aircraft (Boeing 737-700), and one of the forecasting scenarios accounts for this possibility. Northern Air Cargo reported five to six flights per week to DLG in the summer, with two per day the first two weeks in July, and four per week in the winter.
- Lynden Air Cargo uses the Lockheed L-100 for its DLG operations, with 2-3 flights per week in June and July, and only a few charters out of fishing season.

Everts Air Cargo uses MD-80s, and occasionally DC-6s, for its DLG operations, with 3 flights per week in the summer and two per week out of season.

#### 5.3 Aircraft Operations

The 2019 DLG T-100 Domestic Segment dataset (from the Bureau of Transportation Statistics Air Carrier Statistics database) was used to determine base-year aircraft operations at DLG. The T-100 dataset for DLG provided departure and arrival information for each month in 2019, including the specific air carrier, aircraft, number of passengers and seat capacity, pounds of freight, and pounds of mail.

The interviews conducted with air carriers supplement T-100 data with valuable qualitative data to illuminate potential future airport design needs. The T-100 database was preferred for quantitative analysis due to (1) the monthly reporting by certificated U.S. air carriers, (2) the availability of more granular operations data than could be gleaned from interviews, and (3) the fact that Ravn Alaska was filing for bankruptcy during the interview period—liquidating assets and cutting personnel. Ravn Alaska’s bankruptcy also affected its subsidiaries that have conducted operations at DLG, including

Peninsula Airways (d/b/a PenAir). These factors affected the availability of data that could be collected from interviews and would significantly affect the reliability of aviation activity forecasts.

Aircraft operations were categorized by aircraft make and model, Aircraft Approach Category (AAC), and Airplane Design Group (ADG). The AAC and ADG are used to classify aircraft.<sup>44</sup> Knowing an airport's critical aircraft is essential for determining its Airport Reference Code (ARC), which affects DLG's design criteria.

**Table 28: Aircraft Approach Category (AAC)<sup>45</sup>**

AAC	Approach Speed
A	Approach speed less than 91 knots
B	Approach speed 91 knots or more but less than 121 knots
C	Approach speed 121 knots or more but less than 141 knots
D	Approach speed 141 knots or more but less than 166 knots
E	Approach speed 166 knots or more

**Table 29: Airplane Design Group (ADG)<sup>46</sup>**

Group #	Tail Height (ft)	Wingspan (ft)
I	< 20'	< 49'
II	20' - < 30'	49' - < 79'
III	30' - < 45'	79' - < 118'
IV	45' - < 60'	118' - < 171'
V	60' - < 66'	171' - < 214'
VI	66' - < 80'	214' - < 262'

Table 30 summarizes DLG aircraft operations in 2019 by aircraft make and model, AAC, and ADG, as reported in the T-100 database.

**Table 30: Annual DLG Operations by Aircraft, AAC, and ADG (2019)<sup>47</sup>**

AAC - ADG	Aircraft	Annual Operations
A-I	Beech Baron (55 Series)	10
	Beech Bonanza 35A/C/D/E/G/H/J/K/S/V/36A	12
	Cessna C206/207/209/210 Stationair	4,664
	Gipps Aero Ga8 Airvan	2
	Piper PA-31 (Navajo)/T-1020	470
	Piper PA-32 (Cherokee 6)	837
<b>A-I Subtotal</b>		<b>5,995</b>

<sup>44</sup> An airport's critical aircraft refers to the most demanding aircraft that conducts at least 500 annual operations at the airport.

<sup>45</sup> FAA Advisory Circular 150/5300-13A, Airport Design.

<sup>46</sup> Ibid.

<sup>47</sup> Bureau of Transportation Statistics: T-100 Domestic Segment, 2019.

<b>A-II</b>	Casa/Nurtanio C212 Aviocar	2
	Cessna 208 Caravan	2,280
	Pilatus PC-12	156
<b>A-II Subtotal</b>		<b>2,438</b>
<b>B-II</b>	Beech 1900 A/B/C/D	1,399
<b>B-II Subtotal</b>		<b>1,399</b>
<b>B-III</b>	Bombardier BD-700 Global Express	2
	Dassault Falcon 7X	2
	De Havilland DHC8-100 Dash-8	759
	McDonnell Douglas DC-6A	28
	Saab 2000	1,212
<b>B-III Subtotal</b>		<b>2,003</b>
<b>C-II</b>	Saab-Fairchild 340/A	8
	Saab-Fairchild 340/B	20
<b>C-II Subtotal</b>		<b>28</b>
<b>C-III</b>	Boeing 737-100/200	15
	Boeing 737-300	175
	Boeing 737-400	88
	Boeing 737-700/700LR/Max 7	264
	McDonnell Douglas DC-9-30	78
	McDonnell Douglas DC9 Super 80/MD81/82/83/88	199
<b>C-III Subtotal</b>		<b>819</b>
<b>C-IV</b>	Lockheed L100-30/L-382E	168
<b>C-IV Subtotal</b>		<b>168</b>
<b>Total</b>		<b>12,850</b>

The current critical aircraft at DLG is ARC C-III. While C-IV aircraft operations occur at DLG, they do not meet 500 annual operations.

### 5.3.1 Factors Affecting Operations

There are many factors that can affect future aircraft operations at DLG, potentially resulting in a change in critical aircraft. Factors include:

- Freight and passenger fee costs
- Fuel costs
- Changes in fleet mix
- Demographic changes
- Socioeconomic changes
- Capital projects to address FAA requirements or increase operational efficiency

### 5.4 Forecast Scenarios

FAA AC 150/5070-6B, Airport Master Plans, allows several methodologies and techniques for forecasting aviation activity at DLG. Regression analysis was used, applying population and fishing industry data.

First, population data were analyzed. Population projections were prepared targeting the DLG study area. This study area includes the Dillingham Census Area, Bristol Bay Borough, and Lake and Peninsula Borough. Low-growth, base-growth, and high-growth population projections were made using local population projections prepared by the Alaska Department of Labor and Workforce Development (ADOLWD) and McKinley Research Group calculations (See Table 31).

**Table 31: Alaska Statewide and Local Area Population Annual Average Growth Rate Projections, 2020 to 2040 (Percent Change)<sup>48</sup>**

Location	2020-2025	2025-2030	2030-2035	2035-2040
Dillingham Census Area	0.1%	0.1%	0.2%	0.3%
Bristol Bay Borough	-0.5%	-0.8%	-0.4%	-0.4%
Lake and Peninsula Borough	0.4%	0.3%	0.3%	0.3%
Dillingham Airport study area <sup>49</sup>	0.09%	0.04%	0.15%	0.22%
Anchorage	0.4%	0.3%	0.2%	0.1%
Statewide	0.6%	0.5%	0.4%	0.3%

Applying the population projections to base-year (2019) aviation activity, four forecast scenarios were considered for three future milestones: short term (2025), intermediate term (2030), and long term (2040). Forecast scenarios using population projections are the Low Growth Scenario, Base Growth Scenario, High Growth Scenario, and Air Cargo Fleet Change Scenario.

The last (fifth) scenario is called the “Fresh Sockeye Growth Scenario.” This scenario combines the annual growth rate of Dillingham to Anchorage airfreight volumes and the average annual growth rate of Bristol Bay fresh fish production for the same period, applying the hybrid rate to a specific aircraft classification, discussed later. Trend analysis is also used to compare fishing industry data with the various aspects of DLG operations. This fifth scenario specifically considers the largest economic factor impacting operations (specifically cargo) at DLG, where the other four scenarios are based on population projections as previous DLG AMPS have been.

Additional assumptions made when preparing the forecasts include:

- Ravn Alaska’s bankruptcy will not affect demand levels for passenger, freight, and mail service to/from DLG.
- The remaining air carriers will be able to replace the operations formerly provided by Ravn Alaska and its subsidiaries to/from DLG.

<sup>48</sup> Alaska Department of Labor and Workforce Development.

<sup>49</sup> McKinley Research Group calculations.

To account for annual operations growth between 2019 and 2020, the growth rate projections for 2020-2025 were used; negating concern regarding anomalies in operations due to temporary COVID-19 impacts.

#### 5.4.1 Low Growth Scenario

The low growth scenario applies the growth rates from the Bristol Bay Borough population projection to the 2019 DLG aircraft operation counts. This scenario assumes that DLG study area’s projected growth between 2019 and 2040 will be similar to the projected rates of change for the Bristol Bay Borough (see Bristol Bay Borough in Table 31 above).

**Table 32: 2019 to 2040 DLG Aircraft Operations Forecast: Low Growth Scenario**

AAC-ADG	Annual Operations (2025)	Annual Operations (2030)	Annual Operations (2040)
A-I	5,817	5,588	5,369
A-II	2,366	2,273	2,183
B-II	1,358	1,304	1,253
B-III	1,944	1,867	1,794
C-II	27	26	25
C-III	795	763	733
C-IV	163	157	150
<b>Total</b>	<b>12,469</b>	<b>11,978</b>	<b>11,508</b>

#### 5.4.2 Base Growth Scenario

The base growth scenario applies the growth rates from the DLG study area population projection to the 2019 DLG aircraft operation counts. This scenario assumes that DLG study area’s projected growth between 2019 and 2040 will be similar to the weighted average for the three study area sub-regions’ projected rates of change (Dillingham Census Area, Bristol Bay Borough, and Lake and Peninsula Borough; see Dillingham Airport study area in Table 31 above).

**Table 33: 2019-2040 DLG Aircraft Operations Forecast: Base Growth Scenario**

AAC-ADG	Annual Operations (2025)	Annual Operations (2030)	Annual Operations (2040)
A-I	6,027	6,040	6,152
A-II	2,451	2,456	2,502
B-II	1,407	1,409	1,436
B-III	2,014	2,018	2,056
C-II	28	28	29
C-III	823	825	840
C-IV	169	169	172
<b>Total</b>	<b>12,920</b>	<b>12,945</b>	<b>13,187</b>



### 5.4.3 High Growth Scenario

This scenario applies the growth rates from the Dillingham Census Area population projection to the 2019 DLG aircraft operation counts. This scenario assumes the study area’s projected growth between 2019 and 2040 will be similar to the projected rates of change for the Dillingham Census Area (see Dillingham Census Area in Table 31 above).

**Table 34: 2019-2040 DLG Aircraft Operations Forecast: High Growth Scenario**

AAC-ADG	Annual Operations (2025)	Annual Operations (2030)	Annual Operations (2040)
A-I	6,031	6,061	6,215
A-II	2,453	2,465	2,527
B-II	1,407	1,414	1,450
B-III	2,015	2,025	2,076
C-II	28	28	29
C-III	824	828	849
C-IV	169	170	174
<b>Total</b>	<b>12,927</b>	<b>12,992</b>	<b>13,321</b>

### 5.4.4 Air Cargo Fleet Change Scenario

In this scenario, Northern Air Cargo goes forward with the fleet change it is considering and uses only Boeing 737-800s for DLG operations, instead of the series 100, 200, 300, and 400 aircraft it used in 2019. This scenario was considered because, during interviews with air carriers, Northern Air Cargo was the only carrier planning a fleet change to an aircraft more demanding than the current critical aircraft.

For all DLG operations conducted by Northern Air Cargo in the base year (2019), the aircraft used is replaced with the Boeing 737-800 for projected years 2020-2040. The growth rates from the high growth scenario were applied to the three future milestones.<sup>50</sup> The reason for testing this scenario was to learn whether the 737-800—categorized as a D-III aircraft—would exceed 500 annual operations by 2040, since D-III aircraft are more demanding than DLG’s current critical aircraft, which is the Boeing 737-700 (C-III). The following table shows the fleet Northern Air Cargo used for its 2019 DLG operations.

**Table 35: Northern Air Cargo Fleet, DLG Operations (2019)**

Aircraft	AAC-ADG	Annual Operations
<b>Boeing 737-100/200</b>	C-III	15
<b>Boeing 737-300</b>	C-III	175
<b>Boeing 737-400</b>	C-III	78
<b>Total</b>		<b>268</b>

This scenario assumes a fleet change taking place in 2020, which would alter the total number of C-III and D-III aircraft operations at DLG in 2020 (move 268 operations from the C-III category to D-III). Operations in the remaining ARC categories would continue to grow at their expected rates:

<sup>50</sup> During the interviews with air carriers, only Northern Air Cargo mentioned a potential fleet change to aircraft that are more demanding than DLG’s current critical aircraft.

**Table 36: Northern Air Cargo Fleet Change Effect on DLG Operations, by ARC Category**

AAC-ADG	Annual Operations (2019)	Annual Operations (2020)
C-III	819	551
D-III	0	268

**Table 37: 2019-2040 DLG Aircraft Operations Forecast: Air Cargo Fleet Change Scenario**

AAC-ADG	Annual Operations (2025)	Annual Operations (2030)	Annual Operations (2040)
A-I	6,031	6,061	6,215
A-II	2,453	2,465	2,527
B-II	1,407	1,414	1,450
B-III	2,015	2,025	2,076
C-II	28	28	29
C-III	554	557	571
C-IV	169	170	174
D-III	269	271	278
<b>Total</b>	<b>12,926</b>	<b>12,991</b>	<b>13,320</b>

Following a fleet change by Northern Air Cargo, D-III operations are not projected to meet 500 annual operations by 2040.

#### 5.4.5 Comparison with Federal Aviation Administration Forecast

The most recent TAF predicts a slow but steady increase in operations at DLG through 2040. Air carrier operations are predicted to increase between 0.523% and 0.594% annually through 2040. Air taxi and commuter operations are expected to increase 0.976% to 1.006% annually through 2040. The growth rates in the TAF fall within the growth rates used for the base growth and high growth scenarios, based on population projections.

#### 5.4.6 Fresh Sockeye Growth Scenario

While population is certainly a factor affecting aviation activity at DLG, analysis of the operations data indicated that population changes in the DLG study area from 2010-2019 did not adequately correlate with changes in certain aircraft operations counts. Because of the significant role of the fishing sector in the local economy, it was hypothesized that local fish processing data would have a stronger correlation with DLG operations for certain aircraft or carriers associated with freight movement.

After further analysis, fish processing data were narrowed to Bristol Bay fresh sockeye, excluding other processing types for Bristol Bay sockeye. This is because fresh sockeye generally needs to be flown to its destination to avoid spoilage. Alternatively, canned, frozen, and other processing types are typically barged out of Dillingham due to the longer time table.

This scenario will demonstrate the following:

1. Changes in fresh sockeye processing volumes significantly affect DLG cargo volumes.
2. Changes in DLG cargo volumes from increased fresh sockeye processing affect C-IV aircraft operations.
3. Significant, long-term growth in regional fresh sockeye processing is expected.
4. Sockeye processing growth is reasonably likely to change the ARC at DLG to C-IV by 2040.

**Changes in Fresh Sockeye Processing Volumes Significantly Affect DLG Cargo Volumes.**

The annual volume of Bristol Bay fresh sockeye processed has dramatically increased—almost 12X—from just over 1.2 million lbs. in 2014 to 14 million lbs. in 2019. While production of Bristol Bay fresh sockeye has been steady around 14 million pounds annually since 2017, the volume being flown out of Dillingham has been noticeably increasing. In 2017, DLG handled approximately 25% of the total Bristol Bay fresh sockeye volume, rising to 30% in 2018, and 37% in 2019. See Figure 23 for Bristol Bay fresh sockeye volumes and Figure 24 for cargo volumes from DLG to Anchorage.

**Figure 23: Annual Bristol Bay Fresh Sockeye Processed, thousand lbs. vs. Annual DLG Operations<sup>51</sup>**

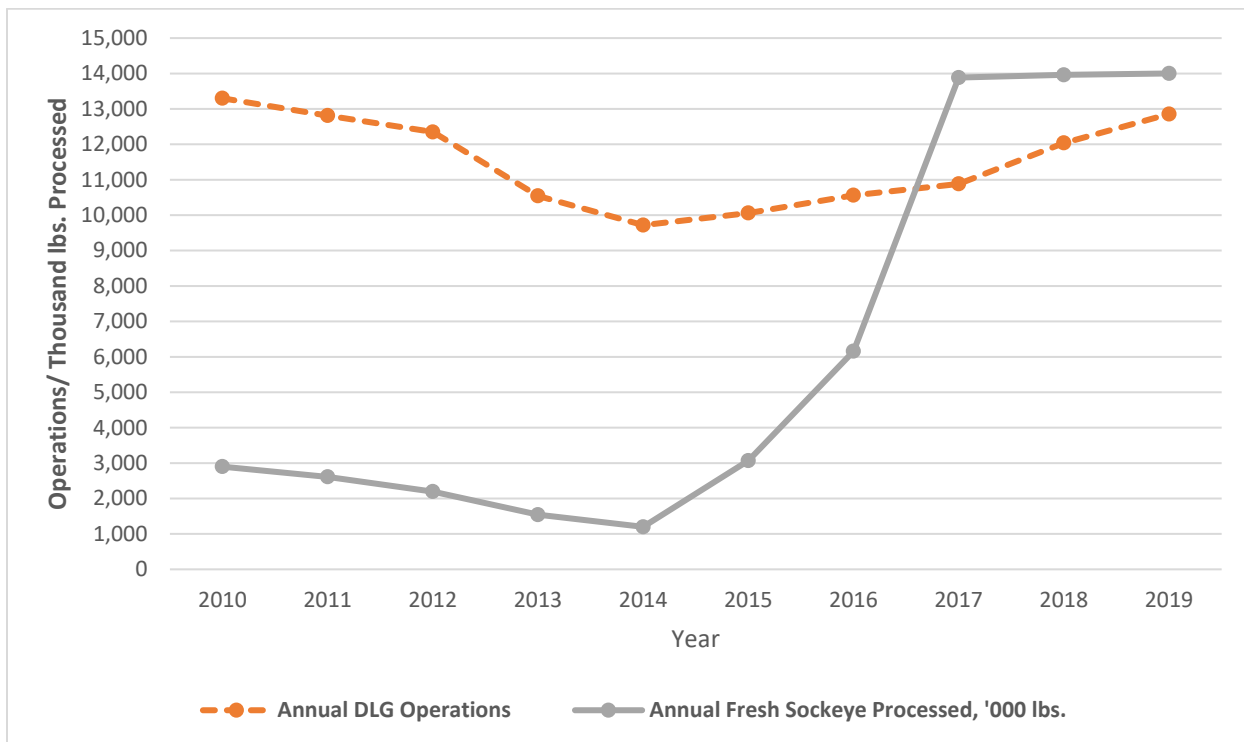

During the 2019 salmon fishing season (June to August), almost 2,700 tons of cargo were shipped from Dillingham to Anchorage (or 92% of all cargo departing from Dillingham). Approximately 160 tons were shipped in the other nine months combined.

<sup>51</sup> BTS T-100 and ADFG COAR Data, [https://www.adfg.alaska.gov/index.cfm?adfg=commercialbyareabristolbay.salmon\\_sockeye\\_coar](https://www.adfg.alaska.gov/index.cfm?adfg=commercialbyareabristolbay.salmon_sockeye_coar).

Figure 24: Seasonal Air Cargo from Dillingham to Anchorage, thousand lbs., 2010-2020<sup>52</sup>

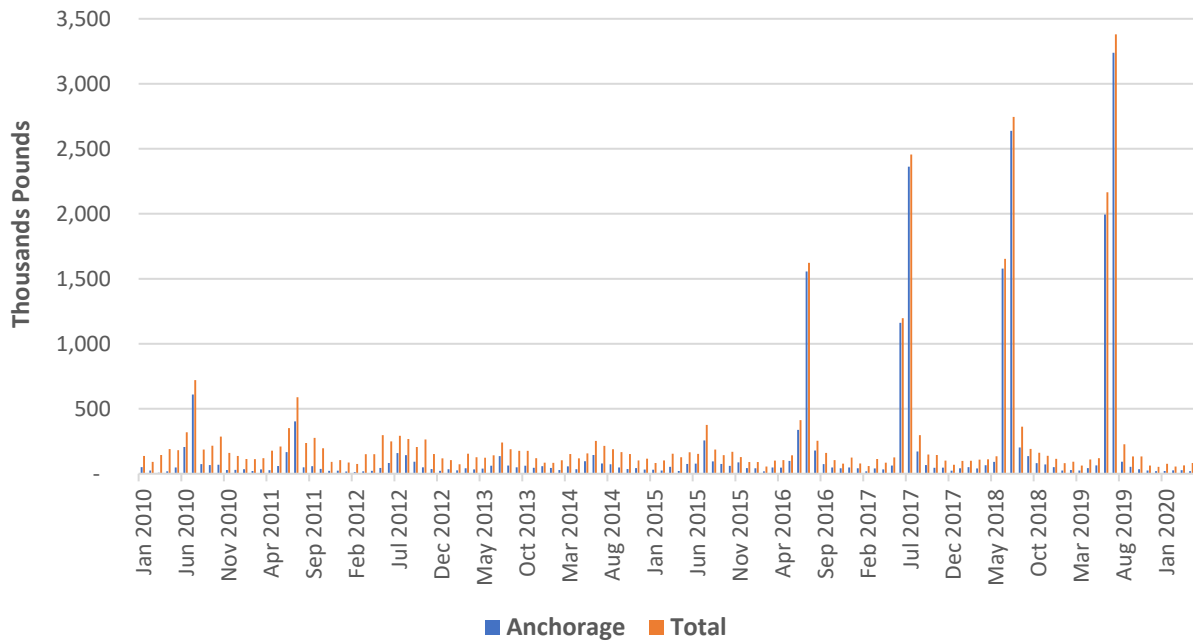

Note that cargo volumes from Anchorage to DLG remained relatively constant while outgoing cargo from DLG continues to rise, further evidence of fresh sockeye’s effect on outgoing cargo volumes. See Figure 25.

Figure 25: Dillingham Airport Historical Annual Freight Volumes, 2010-2019<sup>53</sup>

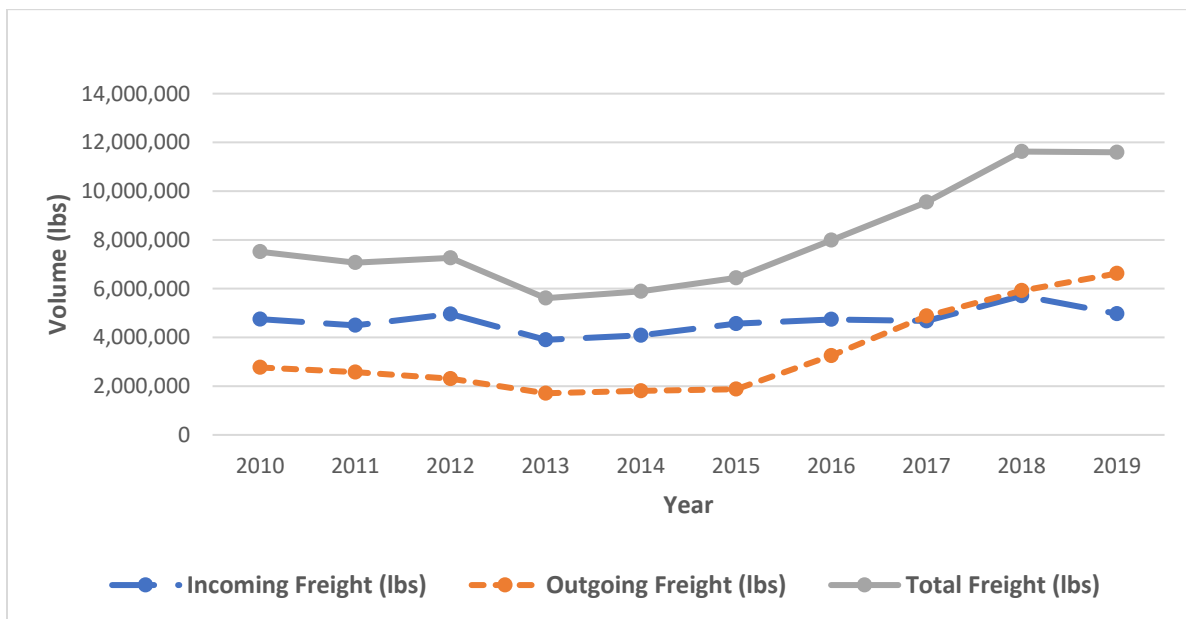

<sup>52</sup> BTS T-100

<sup>53</sup> Ibid.

Many external forces converged in 2017 to provide an opportunity for shore-based Bristol Bay processors to aggressively increase the volume of product shipped to fresh fish markets. Prior to 2017, fresh sockeye was primarily sourced from Cook Inlet and Copper River. Both areas saw low returns in 2017 while Bristol Bay saw the first in a string of large returns, opening the door for Bristol Bay to fill the void in the fresh sockeye market.

Processors in Naknek and Dillingham have the advantage of access to airports with air freight service. One interviewee stated for their operation, “Bristol Bay is now the primary source of fresh sockeye salmon in July,” a market shift that began in 2017<sup>54</sup>. Additionally, the geography of the Nushagak fishing district and Dillingham’s shore-based processing plants allows for quick deliveries of high-quality and high-value sockeye to the fresh market. Major processors OBI and Peter Pan Seafoods both have plans for increasing fresh sockeye production from their Bristol Bay plants.

### **Changes in DLG Cargo Volumes from Increased Fresh Sockeye Processing Affect C-IV Aircraft Operations.**

In 2019, most of the fresh sockeye flown out of Dillingham was on chartered Lynden Air Cargo flights. This is significant, because Lynden uses the Lockheed L-100—a C-IV aircraft—for its operations to and from DLG. With variable market share each year, Alaska Airlines, Northern Air Cargo, and Everts Air have also carried significant volumes of fish over the past four years, but they do not currently use aircraft with an ARC higher than C-III.

Air shipment of fresh sockeye occurs in an extremely concentrated period starting in June and peaking in July. Little fresh fish is shipped outside the June and July harvest season.

Like air cargo volumes spikes, air passenger travel from Dillingham to Anchorage is highly seasonal. June is the peak month for Anchorage passengers arriving in Dillingham, largely associated with the start of the seafood harvest and processing season. In June 2019, Anchorage passengers represented 86% of Dillingham arrivals. During summer peaks in July and August, Anchorage travelers represent over 81% of all passengers departing DLG.

Note that growth in the fresh sockeye market had less of an effect on passenger growth. Accordingly, this scenario will only apply Bristol Bay fresh sockeye processing growth to Lynden Air Cargo operations, excluding operations by other carriers.

---

<sup>54</sup> Interview by McKinley Research Group, November 2020.

Figure 26: Air Passengers from Dillingham to Anchorage, Number of Passengers, 2010-2020<sup>55</sup>

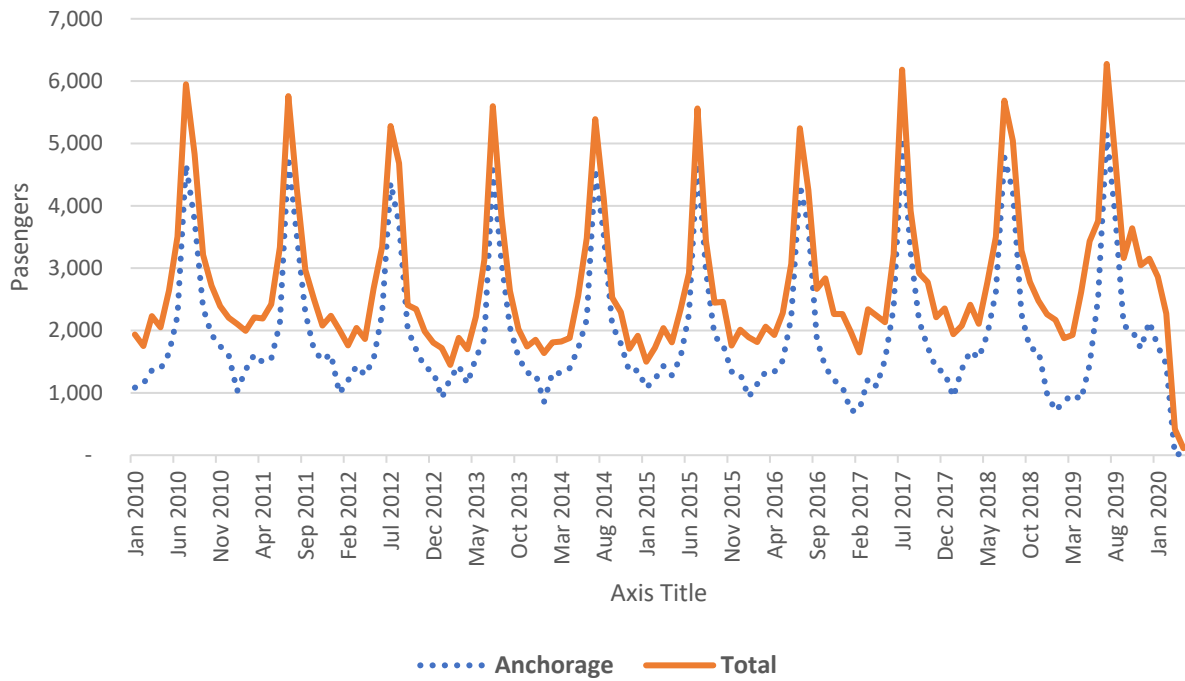
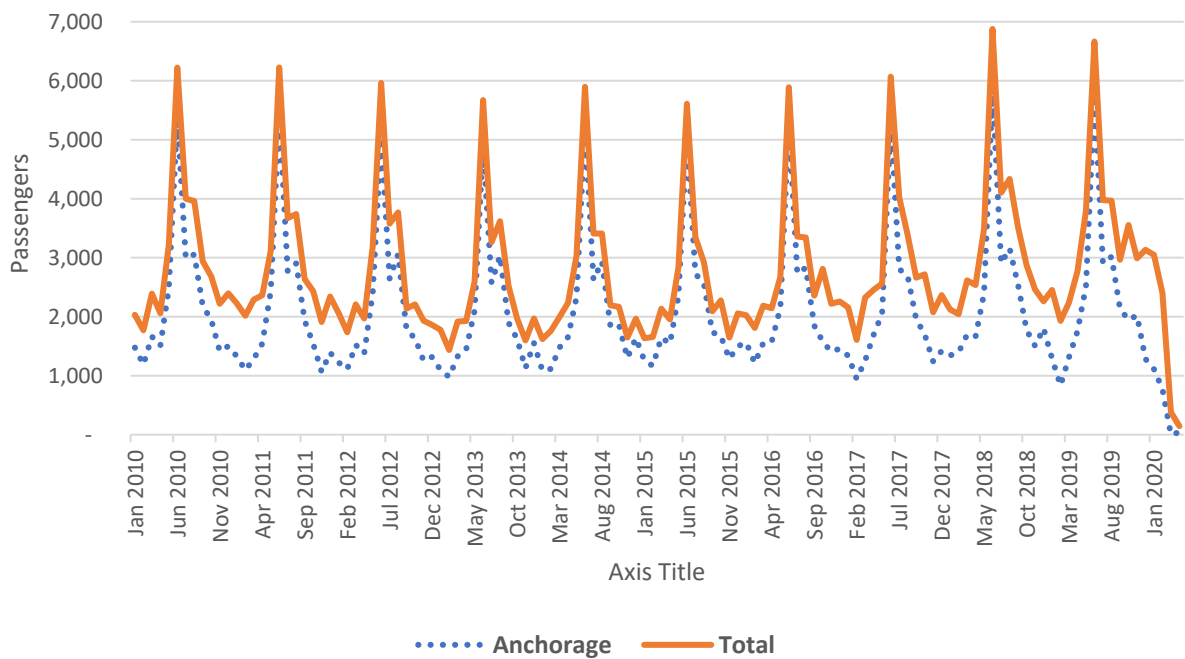

Figure 27: Air Passengers from Anchorage to Dillingham, Number of Passengers, 2010-2020<sup>56</sup>



<sup>55</sup> BTS T-100.

<sup>56</sup> Ibid.

**Significant, Long-Term Growth in Regional Fresh Sockeye Processing is Expected.**

In general, fresh sockeye markets have been strong and look to continue to grow into the future. Both Peter Pan Seafoods and OBI Seafoods have shifted aspects of their operations to capitalize on the fresh sockeye market and the opportunity provided by proximity to DLG.

There is unconstrained potential supply of fresh salmon from Bristol Bay, since fresh fish accounted for only 9% of production in 2019, with most sold as a frozen product (Figure 28). Market demand and infrastructure development (in Dillingham and Anchorage) will likely drive growth in production and shipments.

**Figure 28: Bristol Bay Sockeye, by Processing Type, Million lbs., 2010-2019<sup>57</sup>**

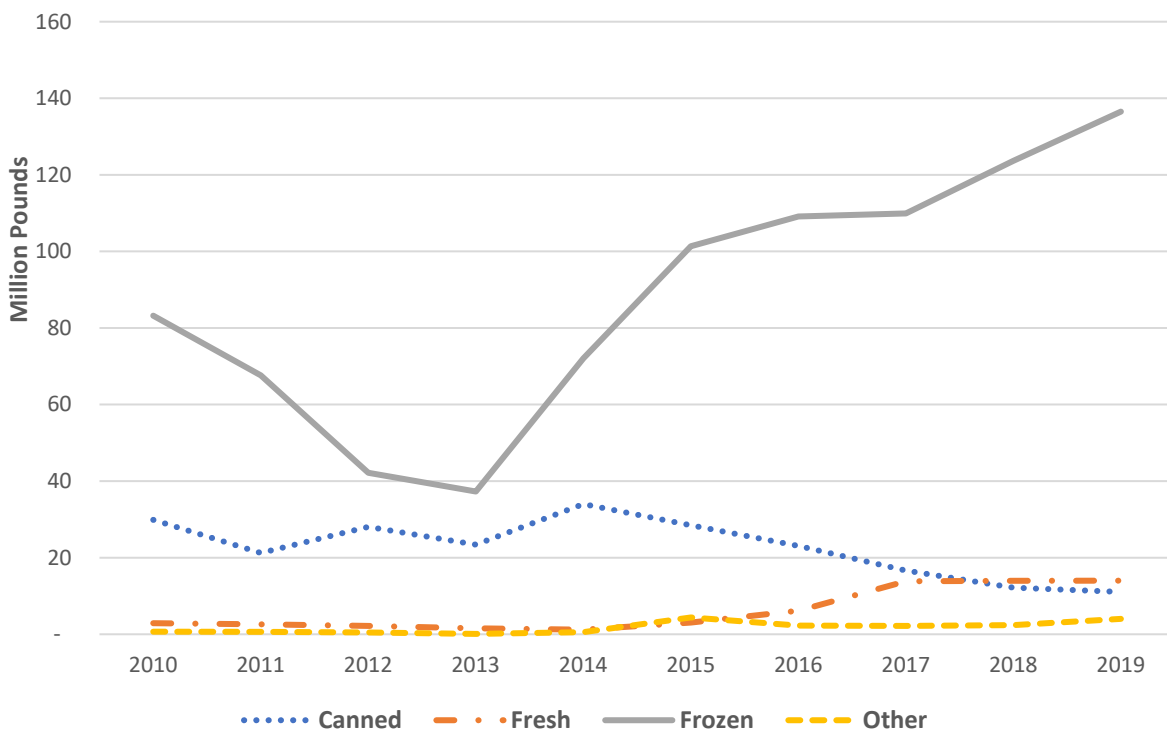

**Sockeye Processing Growth is Reasonably Likely to Change the ARC at DLG to C-IV by 2040.**

An important caveat to this section is that it is not possible to predict with certainty the volume of fresh fish that will be flown out of Dillingham in the future, given uncertainty about the strength of competitive sockeye runs elsewhere in Alaska; however, available data indicates that continued growth is likely, that that growth could result in DLG’s ARC increasing to C-IV by 2040.

Additionally, the timing of development of the Anchorage Cargo and Cold Storage facility may also be a factor. This facility is expected to facilitate movement of fresh Alaska fish to domestic and overseas markets, and would further improve capacity to receive increasing volumes of fresh sockeye from DLG.

<sup>57</sup> ADFG COAR Data, [https://www.adfg.alaska.gov/index.cfm?adfg=commercialbyareabristolbay.salmon\\_sockeye\\_coar](https://www.adfg.alaska.gov/index.cfm?adfg=commercialbyareabristolbay.salmon_sockeye_coar).

A reasonable forecast can be developed by blending the annual growth rate of Dillingham to Anchorage airfreight volumes in June and July for the 2017 to 2019 period (14.1%) and the average annual growth rate of Bristol Bay fresh fish production overall for the same period (0.4%). This produces an annual average growth rate of 7.25%.

While representing substantial growth when compounded over a 20-year period, it is reasonable given the abundance of supply, increasing consumer appreciation for fresh fish from Bristol Bay, processor interest in shifting to production of more (and higher-value) fresh fish, and supporting infrastructure development that is likely to occur in the relatively near-term. Reflecting an annual growth rate in fresh fish shipments of 7.25%, Figure 29 provides projected total annual airfreight poundage moving from Dillingham to Anchorage in 2025, 2030, and 2040.

**Figure 29: Projected Annual Airfreight from Dillingham to Anchorage, Pounds, 2020, 2025, 2030, and 2040**

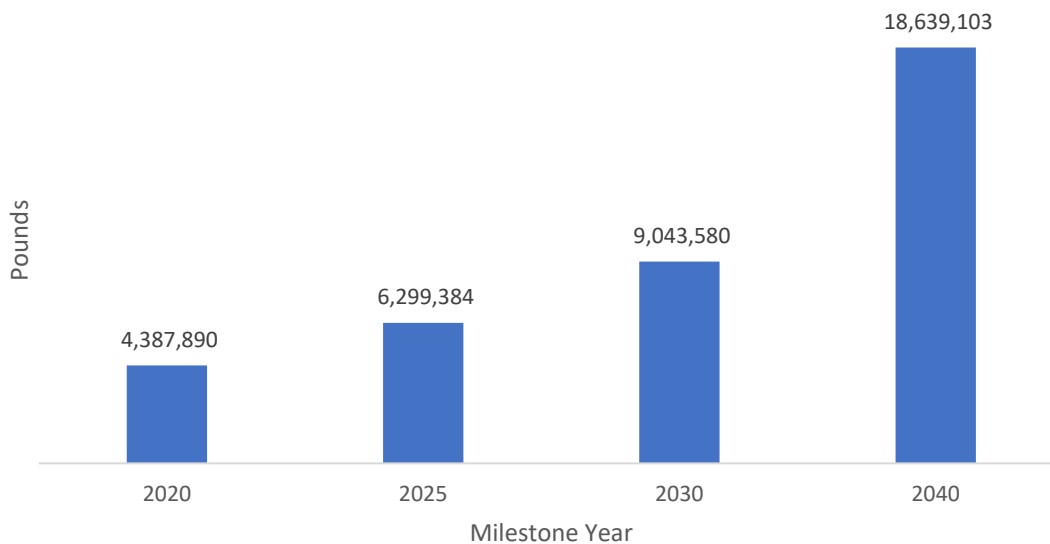

As projected above, fresh fish would account for 12% of total Bristol Bay production by 2030 and about 18% of production by 2040. In 2019, Alaska produced and sold 60 million pounds of fresh salmon, including 29 million pounds of fresh sockeye. Holding production from all other areas constant, the projected Bristol Bay increase by 2030 (about 4.7 million additional pounds) would represent an overall increase in Alaska fresh salmon production of about 8%, and by 2040 (about 14.3 million additional pounds) about 24%. Statewide fresh sockeye production would rise by about 16% and about 49% in 2030 and 2040, respectively.

Based on the assumption that all the increase in airfreight illustrated in the preceding figure is fresh fish (4.7 million additional pounds by 2030 and 14.3 million additional pounds by 2040), and the assumption that fish is shipped over a six-week period in June and July, daily outbound fresh salmon airfreight would average about 111,000 pounds/day in 2030 and about 340,000 pounds/day by 2040.

At an average of 45,000 pounds per flight, approximately two to three additional flights per day (averaged over six weeks) would be required. By 2040, seven to eight additional flights per day would be



needed. This could mean 504 DLG operations with C-IV aircraft by 2040 (projecting from 2019 operations).

### 5.5 Critical Aircraft

Critical Aircraft determinations and aviation forecasts should be determined through analysis of the most relevant indicators. Therefore, low, base, and high growth scenarios calculated using population projections may be used to forecast operations growth for aircraft with ARCs other than C-IV. C-IV aircraft operations projections should use the growth rate provided in the Fresh Sockeye Growth scenario.

Given that Lynden Air Cargo performed 168 operations at DLG with a Lockheed L-100 in 2019, an additional 8 operations per day during the six-week period would mean 504 annual flights with a C-IV aircraft by 2040. If this occurs, the Lockheed L-100 would become the new critical aircraft.

This result only considers Lynden’s forecasted growth—it is possible that other carriers will similarly upgrade their fleet to more demanding aircraft to accommodate the increasing freight volumes.

Additionally, while the pending Northern Air Cargo fleet change to the 737-800 for DLG operations would not result in D-III aircraft exceeding 500 operations by 2040, the combination of this and the increase in C-IV aircraft operations may have important pavement implications at DLG.

Considering these factors, DLG’s current critical aircraft classification is C-III, and the forecasted critical aircraft classification is C-IV by 2040.

## 6.0 Demand-Capacity Analysis

The purpose of the Demand-Capacity Analysis is to determine:

1. DLG’s hourly and annual capacity to facilitate air traffic
2. How current demand relates to capacity

Regarding hourly capacity, this analysis estimates that DLG can accommodate 68 mixed operations (arrivals and departures) during Visual Meteorological Conditions (VMC) and 42 mixed operations during Instrument Meteorological Conditions (IMC).

Annual capacity at DLG is estimated at 118,530 operations. On an annual basis, demand is an estimated 20.1% of capacity, although demand increases to 78% of capacity in July—the peak month. A limitation of this estimate is that aggregation to yearly or monthly demand does not account for days or hours when demand at DLG may exceed capacity. Airport congestion will affect the movement of fresh fish and game, which is sensitive to delays.

See Appendix B for the full Demand-Capacity Analysis report.

Guidance for estimating airport capacity was provided in the Airport Cooperative Research Program Report 79 (ACRP 79), *Evaluating Airfield Capacity* and the accompanying *Prototype Airfield Capacity Spreadsheet Model User’s Guide*.

This analysis determines “maximum sustainable throughput” to compare demand and capacity at DLG. Determining maximum sustainable throughput answers the question, “How many aircraft operations can an airfield reasonably accommodate in a given period of time when there is a continuous demand for service during that period?”<sup>58</sup>

### 6.1 Average Hourly Capacity

Average hourly capacity refers to the number of operations an airport can sustainably facilitate each hour.<sup>59</sup>

The Spreadsheet Capacity Model was provided by FAA and was used to calculate the hourly aircraft operations capacity at DLG. Runway (RW) 1-19 is the only runway at DLG, so there is no separation of Class A-D aircraft, which use RW 1-19 for 100% of DLG operations.

RW 1-19 can be accessed via perpendicular taxiways A or B. Since there is no parallel taxiway, aircraft must taxi on the runway and turn around before taking off. This is inefficient and can add to delays, particularly during the summer fishing season when DLG experiences its highest air traffic volumes.

The Spreadsheet Capacity Model uses the following inputs to determine hourly capacity:

- Aircraft fleet mix
- The Percentage of visual meteorological conditions (VMC) occurrence vs. instrument meteorological conditions (IMC)
- Arrival runway occupancy time & approach speeds
- Runway exit availability
- Type of parallel taxiway (i.e. full, partial, or none)
- Availability of an air traffic control tower
- Runway crossings
- Percent of touch-and-go activity
- Length of common approach
- Departure-arrival separation
- Arrival gap spacing buffer
- Departure hold buffer
- Arrival-arrival & departure-departure separation requirements

Since robust data were not available to determine the exact fleet mix of GA aircraft when calculating the total fleet mix at DLG, two GA scenarios were tested for sensitivity analysis. In the first scenario, all GA aircraft listed in the 5010 were assumed to be single engine aircraft with a maximum takeoff weight (MTOW) less than 12,500 pounds. In the second scenario, review of the most recent aerial imagery of DLG’s GA apron revealed approximately 13% of the aircraft to be twin-engine aircraft, assumed to have an MTOW less than 12,500 pounds. Both mixes were used in the spreadsheet model to determine whether there was a significant difference in hourly capacity.

Given the inputs used, Table 38 shows the hourly capacity at DLG. The capacity changes based on the given meteorological conditions (i.e. VMC and IMC) and type of operations (i.e. arrivals only, departures

---

<sup>58</sup> ACRP Report 79, *Evaluating Airfield Capacity*, The National Academies Press, (2012): 3.

<sup>59</sup> ACRP Report 79, *Evaluating Airfield Capacity*, The National Academies Press, (2012): 3.

only, and mixed operations). Scenarios 1 and 2, using different GA aircraft fleet mixes, did not affect hourly capacity at DLG.

**Table 38: Hourly Capacity at DLG**

	<b>VMC</b>	<b>IMC</b>	<b>Average</b>
<b>Arrivals Only Capacity</b>	3	3	3
<b>Arrivals Capacity (including TNG's)</b>	3	3	3
<b>Departures Only Capacity</b>	87	58	81
<b>Mixed Ops – Departure Capacity (including TNG's)</b>	64	39	60
<b>Total Mixed Operations Capacity</b>	68	42	63
<b>Arrivals Percentage</b>	5%	7%	5%

## 6.2 Annual Service Volume

Annual service volume refers to an airport’s capacity to facilitate operations over a span of one year.<sup>60</sup>

The Annual Service Volume Estimation Model was provided by FAA and was used to calculate the annual aircraft operations capacity at DLG. The Annual Service Volume spreadsheet model accounts for differences in runway use, aircraft mix, and weather conditions expected to occur over a typical year.

The ASV estimation model uses the following inputs:

- Annual demand
- Average peak month daily demand
- Average peak hour demand
- VMC vs. IMC occurrence and hourly capacity
- Percentage operations reduction for maintenance

Given the input values used, the estimated Annual Service Volume is 118,530. The Annual Service Volume spreadsheet model shows 131,700 annual operations since the 10% operations reduction for maintenance activities was not included. With an annual demand of 23,841 operations, the annual demand capacity ratio is approximately 0.201, meaning that current demand is 20.1% of available capacity.

Due to the highly seasonal nature of DLG operations, this capacity estimate can be somewhat misleading. In the winter months, operations may be well below demand, whereas demand may meet or exceed capacity during peak hours in the summer months when the fishing industry is most active. BTS TranStats shows an average delay between 30.22 and 51.11 minutes from 2016 to 2021<sup>61</sup> (Figure 30). Delays indicate capacity exceedance.

To further illustrate, an annual capacity of 118,530 indicates a monthly capacity of approximately 9,878 (i.e. 118,530/12). At 7,750 July operations, July’s demand could, on average, be closer to 78% of capacity.

<sup>60</sup> ACRP Report 79, *Evaluating Airfield Capacity*, The National Academies Press, (2012): 3.

<sup>61</sup> “Dillingham, AK: Dillingham Airport (DLG),” Bureau of Transportation Statistics, December 31, 2019.

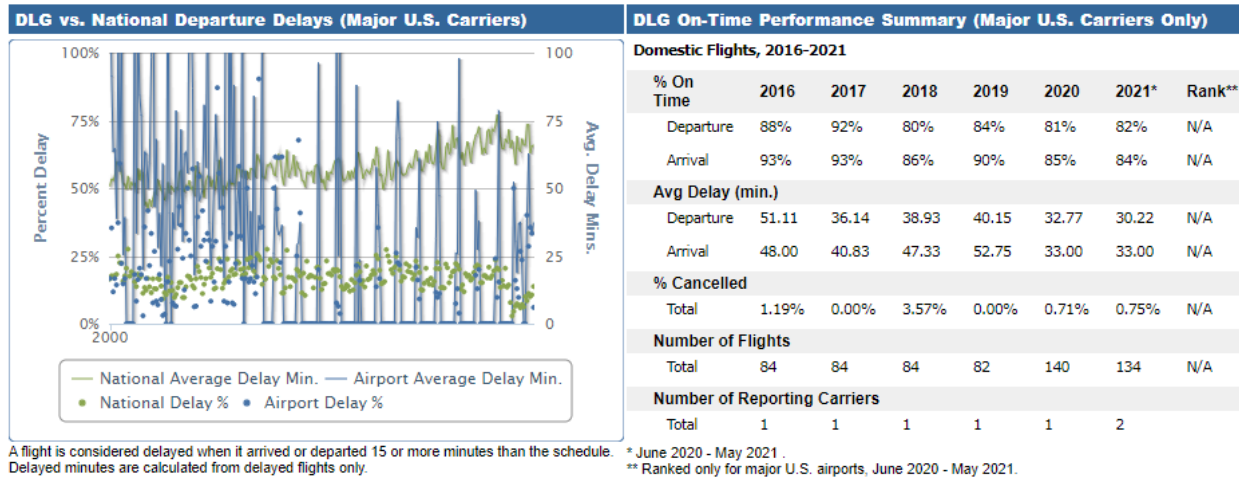

Figure 30: TranStats: DLG (2019)

## 7.0 Facility Requirements

Table 39 presents airport issues identified through public and stakeholder engagement and a May 18, 2021 site visit performed by R&M and DOT&PF Planning.

Table 39: Airport Issues

Category	Issue	Source	Notes
<b>Alaska Airlines/Ravn Air Terminal Building</b>	The passenger waiting area and baggage claim area are not big enough to support the number of passengers during busy times.	Public comments, site visit, stakeholder interviews	A larger, shared terminal was suggested in public comments and stakeholder interviews.
	There is no separation between the passenger waiting area and the gate for security purposes.	Public comments, site visit	
	Restroom facilities are not reliable.	Public comments, site visit, stakeholder interviews	
<b>Amenities</b>	There is no concession space or any vending machines.	Public comments, site visit, stakeholder interviews	One public comment described how nursing mothers are unable to get clean water for baby formula. Another comment described how people often have to wait several hours for connecting flights and do not have reliable access to food unless they bring it with them. The Twin Dragon restaurant was closed in July 2021.

Category	Issue	Source	Notes
<b>Equipment</b>	Glide slope antenna is needed to upgrade to a precision approach using an instrument landing system.	Previous AMP	A precision approach and decreased visibility minimums would increase FAR Part 77 surface dimensions and decrease slopes. Additional obstruction clearing would likely be required to clear the airspace based on FAA determination.
	One ODAL is not functioning north of RW 1-19.	Stakeholder interviews	The airport manager has reported this to FAA for several years.
	It can be very foggy in the winter; a precision approach system would be helpful.	Stakeholder comments	
	Taxiway & runway lighting was last updated in 2003 and needs replacement. The system is nearing failure, with greatly reduced resistance readings, likely due to water inundating the system.	Stakeholder interviews; DOT&PF testing (2019)	It needs to first be determined whether there will be a RW shift, and if so, whether to provide a temporary fix beforehand and then a permanent upgrade following the RW shift, or wait for the shift to do any lighting replacement.
	A thaw wire is needed at the RW End 19 culvert.	Stakeholder interviews, site visit	
	The badging computer station needs to be updated.	Site visit, stakeholder interviews	
	AWOS: proximity to trees is potentially affecting wind direction accuracy. Clearing is needed within 500 feet	Site visit	Wind sensor must be above surrounding tree top elevations per FAA Order JO 6560.20C
<b>Environmental</b>	Presence of PFAS in aquifer on site.	Stakeholder interviews	
<b>Facilities: Condition</b>	The RSA dimensions for RW 1-19 do not meet standards.	Stakeholder interviews	
	There is no clear line of sight between the ends of RW 1-19.	Stakeholder interviews	
	The long-term parking area is not fenced, and theft and vandalism are an issue.	Public comments, site visit	Long-term parking has not been relocated closer to the airport largely due to post-9-11 restrictions.
	Junk vehicles have been left in the long-term parking area beyond the 30-day limit.	Site visit	See Figure 31.

Category	Issue	Source	Notes
	The gates added in 2019 using sensors can malfunction in the winter; the camera lens frosts over.	Stakeholder interviews	There have been complaints by medevac providers over the time-delayed gate opening.
	The Terminal Apron has grading issues. The Terminal Apron holds water near the north end, west of Taxiway B. There is ponding north of Taxiway B, near the Terminal Apron.	Stakeholder interviews	
	The ARFF/SRE building's roof is in poor condition.	CIMP Inspection	Roofing materials are in poor condition; there are visible signs of leaks.
	All lighting has degraded (bad connections, insulation, wiring and transformers). Testing 12.2.2019, Runway ohm resistance reading is 14 ohms and 6.6 megaohms. Taxiway ohm resistance reading is 12 ohms and 0.028 megaohms. According to Item L-108, paragraph 108-3.10 c., "the insulation resistance to ground of all non-grounded series circuits is not less than 2,000 megaohms". The insulation is indicating it is degrading.	CIMP Inspection	Runway lighting is approximately 18 years old.
	Fencing surrounding several areas of RW 1-19 is difficult to access for repairs. Much of the land is wet and not suitable for vehicles, and there is a steep slope at the southeast area beyond the runway. The fence is sloping in several areas.	Site visit, CIMP Inspection	Possibility for a combination of relocating certain fence areas and constructing an interior perimeter access road.  See Figures 32 and 33.
	Several of the smaller culverts at airport access points are in a state of significant disrepair.	Site visit	See Figure 34.
<b>Facilities: Capacity</b>	A Parallel taxiway to RW 1-19 is needed to improve operational efficiency. Pilots currently taxi on the runway before taking off.	Previous AMP, public comments, site visit,	

Category	Issue	Source	Notes
		stakeholder interviews	
	Commercial and GA operations use the same runway, which can cause delays during busy periods; several GA pilots have stated a preference for a gravel runway. Some pilots with tundra tires on their aircraft use the gravel surface in the RSA adjacent to RW 1-19 to land.	Public comments, stakeholder interviews, site visit	During the site visit, there was a small aircraft that used the gravel surface instead of RW 1-19 to land.
	Short-term parking on/near the aprons is regularly full and can be difficult for pedestrians and drivers to safely navigate, especially in the summer.	Public comments	
	There are not enough lease lots to meet current demand.	Public comments	There is a discrepancy between this comment and DOT&PF Leasing (see comment in Operations category), which states a lack of demand for lease lots.
	There are not enough hangars available to meet demand. DOT&PF Statewide Aviation and Leasing encourages project development to include T-hangars.	Public comments	One comment described how pilots must store their plane in King Salmon or other locations over the winter since there isn't available hangar space.
	The Terminal Apron does not have sufficient space to accommodate transient aircraft during busy times. There may be a need to extend the apron north.	Site visit, stakeholder interviews	The ground north of the Terminal Apron is difficult to construct on (wetlands). Extending the apron may also require extending the airport access road to "Lorraine's Road" to access the apron area. If so, traffic control would be needed to halt vehicle traffic for ARFF activities or aircraft taxiing between the GA Apron and runway. It would be difficult for the ARFF truck to make the 90-degree turn, and it may be necessary to move the ARFF truck bay to the

Category	Issue	Source	Notes
			north end of the ARFF building, adding an easterly door and ramp.
	Large areas of tundra are buckling northwest of the RW end 19 RSA due to the constructed embankment. The size of the disturbance ranges from a few inches to over four feet.	Site visit	See Figure 35.
<b>Land Use</b>	Object Free Area is not clear of obstructions.	Stakeholder interviews	
	The Evergreen Cemetery is within the RSA. There is likely public opposition to relocating the cemetery.	Public comments, site visit, stakeholder interviews	See Figure 36.
	The proximity of the airport to residential neighborhoods is a concern if RW 1-19 or the RSA are lengthened or expanded, especially past the north end of the RSA.	Public comments	
	The current airport location has limited opportunities for expansion. Several comments included total relocation.	Public comments, stakeholder interviews	
<b>Operations</b>	West Airport Road is close enough to the GA Apron and Taxiway C that snow clearing at the apron and taxiway puts the snow onto the road.	Stakeholder interviews	
	Current M&O staffing levels are near capacity to maintain existing facilities. New facilities would either require additional staff or, in the case of lease lot improvements, delegating responsibility to tenants.	Stakeholder interviews	
	It has been difficult finding skilled electricians do properly conduct repairs.	Stakeholder interviews	The possibility of sending electricians from Ted Stevens International Airport to rural airports was discussed.
	Industrial and toxic waste is barged out, but there is no regular service for this.	Stakeholder interviews	



Category	Issue	Source	Notes
	There are three vacant lease lots, and no inquiries about lease lots in months.	DOT&PF Leasing	
<b>Utilities</b>	Some transformers have partially sunk into the ditches, increasing exposure to water-related hazards and maintenance issues.	Site visit, stakeholder interviews	It is the Nushagak Electric & Telephone Cooperative's responsibility to maintain the transformers.
	There is a low point southwest of the pump station (gravity line) which causes regular backups.	Public comments, stakeholder interviews	
	Lack of access to potable water. There is no connection to the city water system, and PFAS were discovered in nearby well testing.	Public comments, site visit, stakeholder interviews	



Figure 31: Abandoned Vehicle in Long-Term Parking Lot



Figure 32: Saturated Land, RW 1 End Looking Southeast

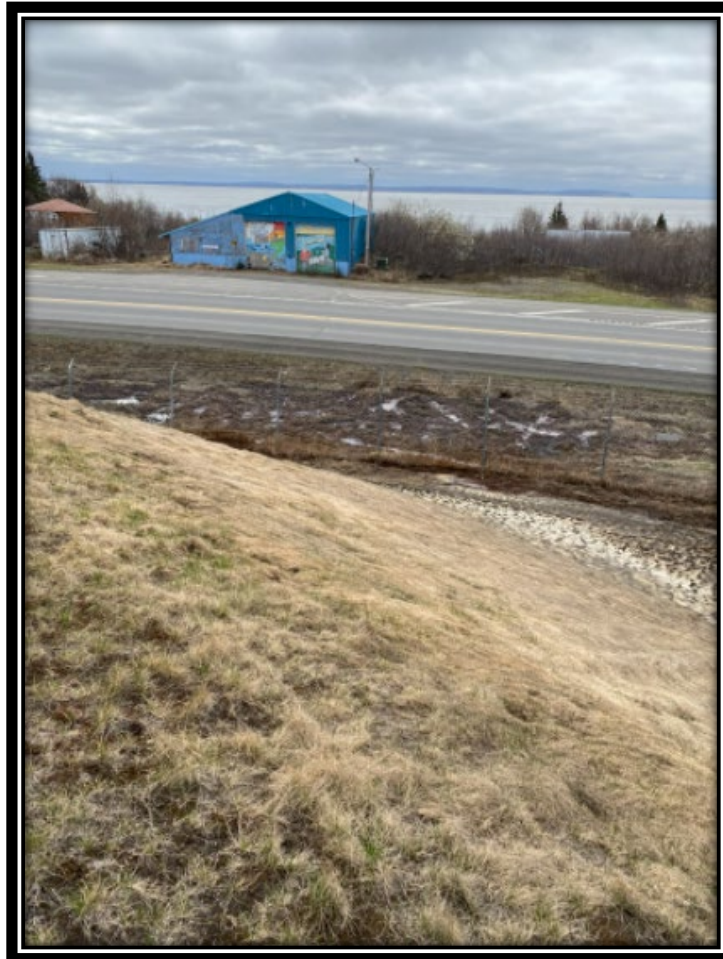

Figure 33: RSA Embankment Slope, RW 1 End Looking Southeast



Figure 34: Culvert by GA Apron Access Point



Figure 35: Surface Irregularities in the Tundra Surrounding the Airport Embankment



Figure 36: Evergreen Cemetery

## 8.0 Alternatives Development & Evaluation

Several alternatives were developed and evaluated for future DLG improvements. These alternatives are broadly separated into RSA alternatives and non-RSA alternatives categories.

### 8.1 RSA Alternatives

The following discussion includes the purpose and need for developing RSA-related alternatives, key constraints limiting improvement options, criteria used to evaluate alternatives, the alternatives considered, and the recommended alternative. See Appendix C: DLG RSA Practicability Study for a more detailed discussion.

Three key factors informing project alternatives development are runway length, RSA dimensions, and runway line of sight (LOS). DLG does not conform to the standards for runway length or RSA dimensions provided in FAA AC 150/5300-13 *Airport Design* for Aircraft Approach Category (AAC)-Airplane Design Group (ADG) C-III and requires additional embankment to meet RSA dimensional standards.

Regarding runway length, RW 1-19 is 6,400 feet, while only 6,000 feet is justified based on the critical aircraft and guidance provided in AC 150/5325-4B *Runway Length Requirements for Airport Design* and AC 150/5000-17 *Critical Aircraft and Regular Use Determination*.

Regarding RSA dimensions, Table 3-5 of AC 150/5300-13A *Airport Design* establishes that the RSA width should be 500 feet centered on the RW centerline, and the length should extend 1,000 feet beyond each end of the RW. The current RSA width is only 350 feet, and the RSA length only extends south 600 feet beyond RW 1. The RSA length extending north beyond RW 19 does meet the 1,000-foot minimum. See Figure 37.

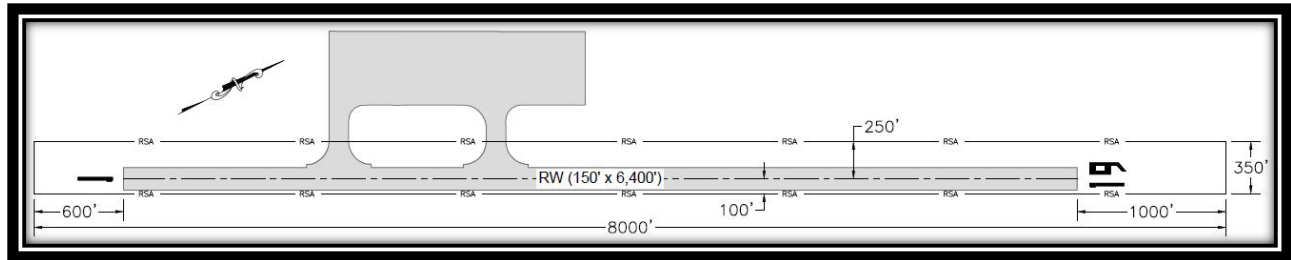

Figure 37: Existing RSA Dimensions

For LOS, AC 150/5300-13 *Airport Design* requires that “any point five feet above the runway centerline must be mutually visible with any other point 5 feet above the runway centerline.” In the existing runway profile configuration, the crest curve near the midpoint of the runway profile violates the five-foot LOS line by 7.2 feet. To fully correct the runway LOS, the RW 19 threshold would need to be raised by 15.7 feet.

### 8.1.1 Site Constraints and RSA Impact Considerations

There are several site constraints around the airport that limit the expansion of the existing RSA.

First, Kananak Road is the main road connection to downtown Dillingham, and it is within the Object Free Area (OFA). There is also a steep slope and 18-foot elevation distance between the south RSA and road, limiting the practicality of expansion southward to meet the required RSA length. See Figure 38.

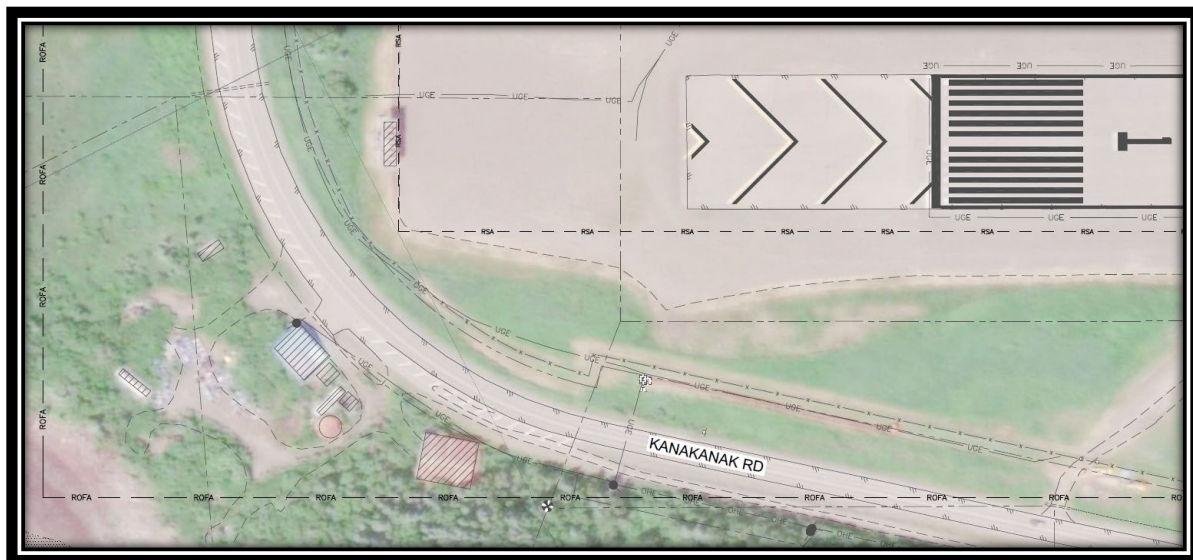
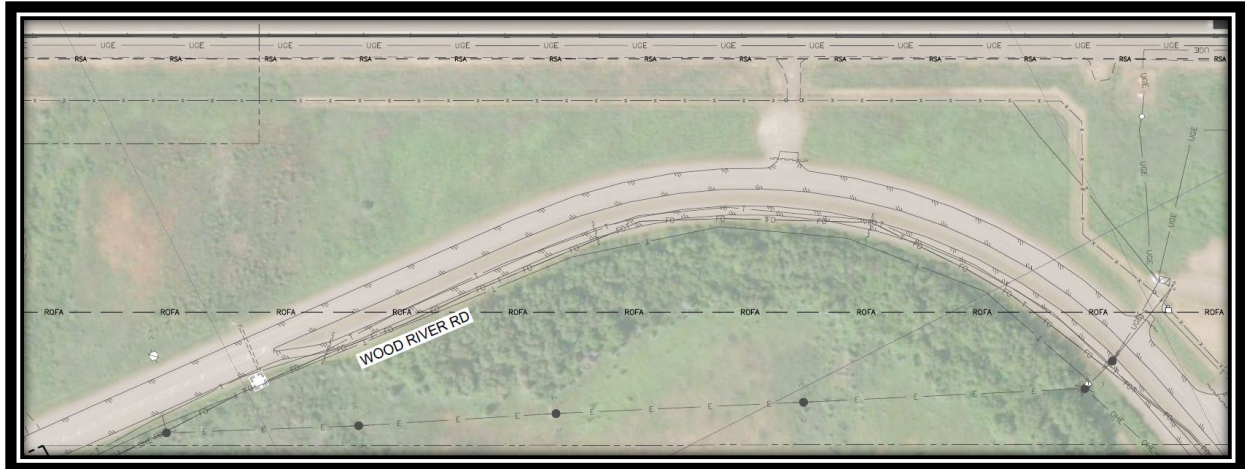

Figure 38: Kananak Road within OFA

Additionally, a portion of Wood River Road curves towards the east edge of the runway, entering airport property and the OFA, limiting eastward RSA expansion. See Figure 39.



**Figure 39: Wood River Road within OFA**

The Evergreen Cemetery runs parallel to the east side of RW 1-19, partially within the airport property interest as a fee property and easement. It is also within the OFA. See Figure 40.

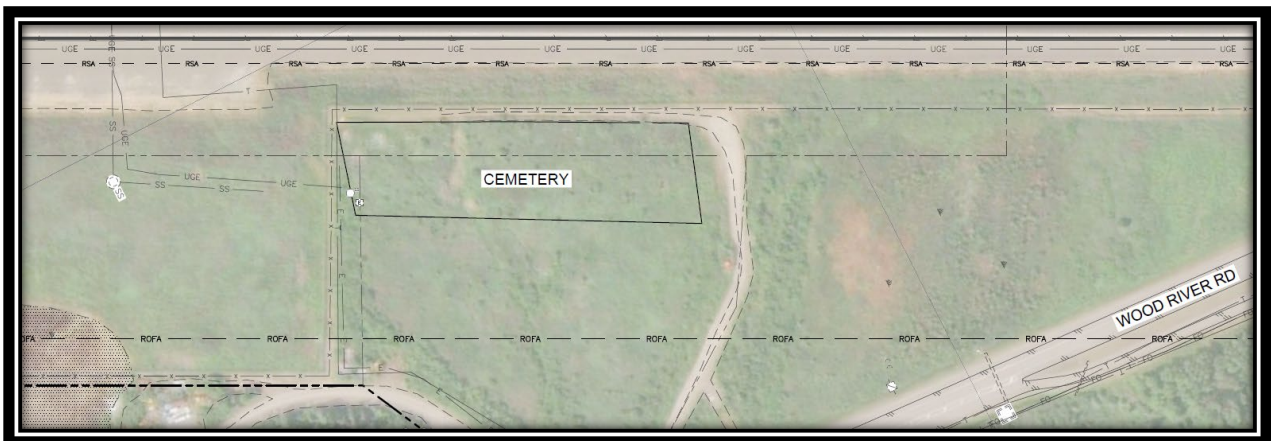

**Figure 40: Evergreen Cemetery within OFA**

Land use and right-of-way (ROW) considerations also affect the feasibility of expanding the RSA to meet requirements. DLG property is surrounded by residential development on all sides except the northeast. Much of the surrounding parcels are held as Alaska Native Allotments. Private land near the southwest portion of the runway potentially affects the ability to improve airport capacity by constructing a parallel taxiway.

The ultimate decision to acquire full or partial parcels will be made closer to an RSA expansion project. The final determination should consider the necessity of the acquisition to protect the RPZs/OFAs/RW approaches, parcel ownership/allotment restricted status, likelihood of success, timeline, costs, existing site development, and BIA control over the subdividing/platting process. The acquisition of aviation and hazard easements should also be considered, especially where airspace obstructions are the only deficiency. AC 150/5300-13A *Airport Design* recognizes that “Land acquisition to protect all possible airspace intrusions is generally not feasible...”

Regarding environmental considerations, extensive wetlands and poor soil conditions<sup>62</sup> in the undeveloped areas of DLG property near the existing runway affect the feasibility of RSA expansion to the northwest and correcting runway LOS.

### 8.1.2 Alternative Evaluation

Four alternatives were fully evaluated for this AMP. Each alternative was assessed according to the following primary categories:

- Airport impacts
- Roadway and utility impacts
- Cemetery impacts
- ROW, obstruction, and LOS impacts
- Environmental Impacts and Geology
- Cost

Three additional alternatives considered but ultimately deemed infeasible were (1) the use of an Engineered Material Arresting System (EMAS), (2) runway rotation, and (3) airport relocation.

The following four alternatives were considered for their practicability:

- Alternative 1: Offset RW 150' west
- Alternative 2: Offset RW 150' west, shift RW 1 threshold 400' north
- Alternative 3: Expand existing RSA
- Alternative 4: No build, publish declared distances

### 8.1.3 Alternative 1: Offset RW 150' West

This alternative would offset the runway 150 feet west of the current location. The new west runway edge will be at the current west edge of the RSA, so the RSA will need to be widened 150 feet to the west to meet standards. The runway length would remain 6,400 feet, exceeding the required runway length for the critical aircraft. The safety area to the south would meet standards by the implementation of declared distances. The RW 19 Landing Distance Available (LDA) and Accelerate-Stop Distance Available (ASDA) would be decreased to 6,000 feet. See Figure 41.

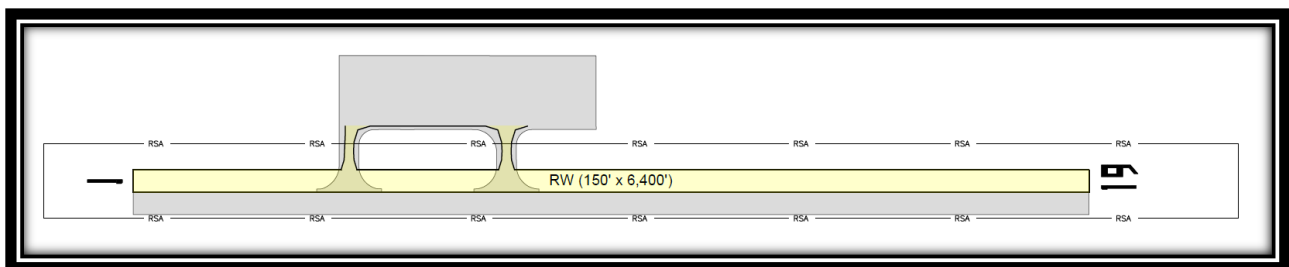

Figure 41: Alternative 1

<sup>62</sup> Mostly compressible peat, underlain by silt.

### 8.1.4 Alternative 2: Offset RW 150' West, Shift RW 1 Threshold 400' North

Like Alternative 1, this alternative achieves RSA width through offsetting the runway and expanding the RSA embankment width 150 to the west. In addition, the RW 1 threshold would be shifted 400 feet north along this new runway centerline, resulting in a runway length of 6,000 feet. See Figure 42.

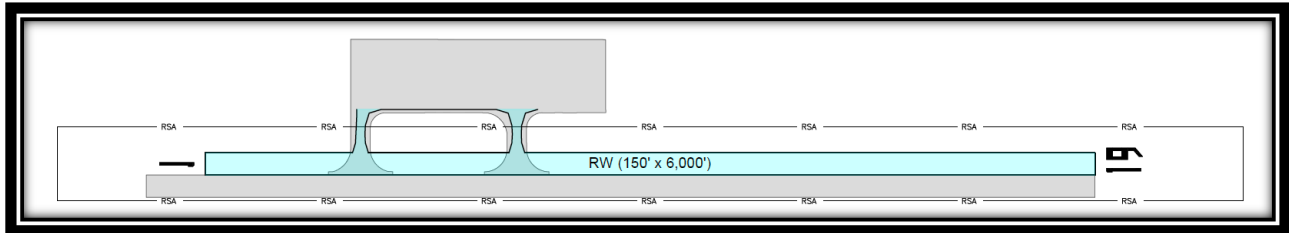

Figure 42: Alternative 2

### 8.1.5 Alternative 3: Expand Existing RSA

Alternative 3 consists of expanding the RSA embankment around the existing runway. See Figure 43.

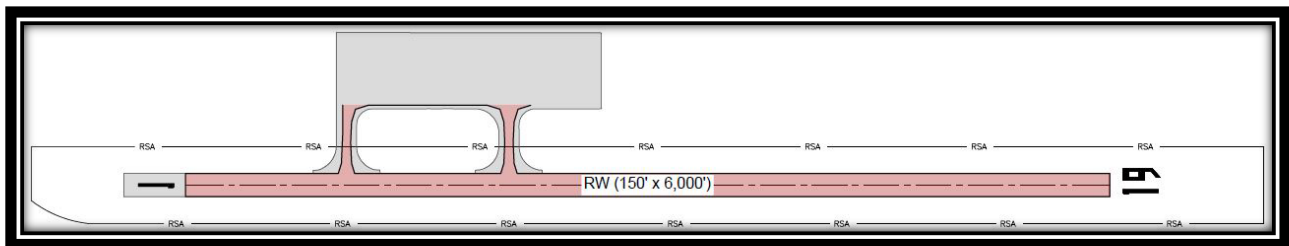

Figure 43: Alternative 3

### 8.1.6 Alternative 4: No Build, Publish Declared Distances

This alternative would provide no constructed improvements to the existing conditions of the airport. The RSA embankment width would remain below FAA AC 150/5300-13A *Airport Design* standards at 350 feet and not centered around the runway. Declared distances may be published to improve the south RSA length beyond the RW 19 departure end to meet standards. See Figure 44.

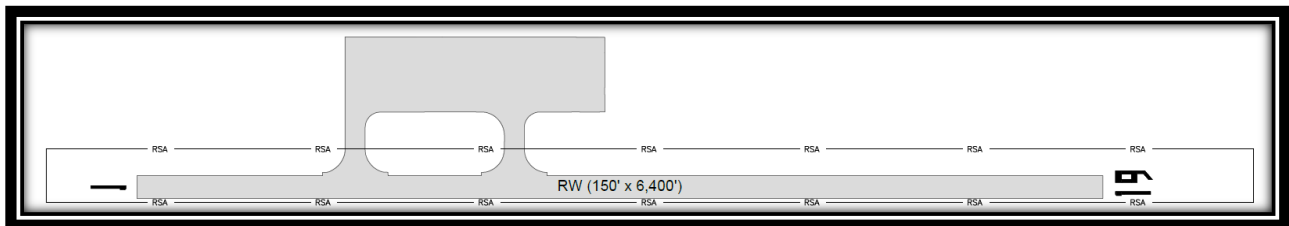

Figure 44: Alternative 4

### 8.1.7 Recommended Alternative

A matrix summarizing comparing the alternatives and impacts is presented in Table 40. Alternative 2 is the recommended alternative, because it obtains standard RSA dimensions, is in conformance with the



runway length determination, and limits impacts to surrounding infrastructure. Appendix C: DLG RSA Practicability Study includes a full discussion of the expected impacts for each alternative.

**Table 40: Alternatives Matrix**

Component	Alternative 1	Alternative 2	Alternative 3	Alternative 4
<b>Basic Description</b>	Offset RW 150' West	Offset RW 150' West; Shift RW 1 Threshold 400' North	Expand Existing RSA	No Build
<b>RW Length</b>	6,400'	6,000'	6,000'	6,400'
<b>RW &amp; RSA Construction</b>	RW offset 150' west, RSA widened westward to meet 500' standard width; TW A & B shortened to 400'; Declared distances shorten LDA and ASDA to 6,000'	RW offset 150' west, RSA widened westward to meet 500' standard width; TW A & B shortened to 400'; RW 1 threshold shifted 400' north to create 1,000' RSA length to the south	Build RSA around existing RW; RW 1 threshold shifted 400' north to create 1,000' RSA length to the south; Extend RSA east to meet 500' standard width	None. Declared distances shorten LDA and ASDA to 6,000'
<b>RSA Meets Standards?</b>	Yes	Yes	RSA chamfered to avoid impacts to Kananak Rd	No
<b>Re-Align Wood River Road?</b>	Yes, due to minor OFA penetration after RW offset	Yes, due to minor OFA penetration after RW offset	Yes, relocated; Greater OFA penetration without RW offset	No, remains OFA penetration
<b>Re-Align Kananak Road?</b>	No	No	RSA chamfered to avoid impacts	No
<b>Utility Impacts</b>	Relocate telecom & FO lines along Wood River Rd; Relocate electrical vault and SS manholes for lines crossing under the RW	Relocate telecom & FO lines along Wood River Rd; Relocate electrical vault and SS manholes for lines crossing under the RW	Relocate telecom & FO lines along Wood River Rd; No impacts to utilities crossing under the RW midpoint	None
<b>Airport Lighting</b>	Runway edge, threshold, and connecting TW lighting replaced	Runway edge, threshold, and connecting TW lighting replaced	Existing lighting system replaced in kind due to failure, age	Lighting system should be replaced under separate project
<b>Nav aids</b>	ODALs, PAPI/VASI, localizer, and wind cone & segmented circle replaced	ODALs, PAPI/VASI, localizer, and wind cone & segmented circle replaced	Wind cone and segmented circle relocated outside RW OFA (existing deficiency).	No impacts
<b>Evergreen Cemetery Disposition</b>	Remains an OFA penetration; close to new burials, clear trees	Remains an OFA penetration; close to new burials, clear trees	Within the expanded RSA, relocate	No change, remains OFA penetration
<b>Obstruction Clearing</b>	Part 77 and departure surface tree obstructions to the north; OFA terrain leveling	Part 77 and departure surface tree obstructions to the north; OFA terrain leveling	Part 77 and departure surface tree obstructions to the north; OFA terrain leveling (existing deficiencies)	Existing obstructions remain
<b>Property Acquisition</b>	For OFA to the southwest; north RPZ	For OFA to the southwest; north RPZ	For OFA to the east; north RPZ	None

Table 41 compares estimated costs to complete the alternatives, aside from the “no-build” alternative.

**Table 41: Alternative Cost Estimates**

Phase	Alternative 1	Alternative 2	Alternative 3
<b>Design</b>	\$4,800,571	\$4,743,813	\$2,610,677
<b>ROW</b>	\$5,804,000	\$5,804,000	\$4,560,000
<b>Obstruction Removal &amp; Clearing</b>	\$950,000	\$1,116,000	\$938,000
<b>Utilities</b>	\$1,525,000	\$1,525,000	\$1,366,000
<b>RW &amp; RSA Construction</b>	\$36,523,077	\$35,789,501	\$17,030,250
<b>Airport Lighting</b>	\$1,421,940	\$1,421,940	\$1,395,300
<b>Approach Lights &amp; Nav aids</b>	\$1,278,690	\$1,278,690	\$314,220
<b>Road Realignment</b>	\$503,000	\$503,000	\$503,000
<b>Total Estimate:</b>	<b>\$52,806,278</b>	<b>\$52,181,944</b>	<b>\$28,717,447</b>

## 8.2 Non-RSA Alternatives

This section discusses the other significant improvement alternatives considered for areas outside of the RSA.

### 8.2.1 Crosswind Runway

Dillingham Airport does not currently have a crosswind runway. Airport property was originally acquired to fit an ultimate crosswind runway. A crosswind runway was depicted in the 2005 Dillingham Airport Layout Plan but was no longer shown in the 2016 DLG ALP. A crosswind runway is generally added when the existing runway is not aligned with the predominant direction of higher speed winds under the majority of conditions.

Per FAA AC 150/5300-13B, Appendix B:

*“The desirable wind coverage for an airport is 95 percent of the time based on the total number of weather observations during the recording period of at least ten consecutive years... If the primary runway orientation provides less than 95 percent wind coverage, evaluate the need for a crosswind runway.”*

Wind coverage and the need for a crosswind runway was examined during the ALP and Master Plan development. The existing primary runway orientation wind coverage for all allowable crosswind components of the fleet mix was analyzed using a current 10-year wind data set, and the results are summarized in Table 42.

**Table 42: Wind Coverage**

RW	Crosswind Component:	10.5 kt	13 kt	16 kt	20 kt
	RDC:	A-I/B-I	A-II/B-II	A-III/B-III/C-I to D-III	>D-III
<b>11/29</b>	ALL WEATHER	90.86%	95.07%	98.26%	99.57%

Source: Dillingham Wind Data, FAA GIS National Climate Data Center, Period: 2011 - 2020

The wind data analysis indicates less than 95 percent wind coverage for Airplane Design Group – Aircraft Approach Category A/B-I aircraft. These smaller planes cannot generally withstand crosswinds as strong as larger planes, crosswind being the component of wind direction oriented perpendicular to their wings. This could possibly warrant the addition of a crosswind runway to bring combined wind coverage for the two runways to over 95 percent. Further, a second runway for smaller planes was a request from airport users; however, the existing runway width of 150-feet is wider than the 60-foot width required for the small aircraft. This wider width allows the aircraft to deviate from crosswinds and remain on the runway, translating to increased crosswind tolerance and wind coverage. For those reasons, a crosswind runway was not proposed for the ultimate airport configuration.

### 8.2.2 Shared Terminal Facility

A shared terminal facility was requested by many airport users during the condition and needs assessment. As is common for rural Alaskan airports, the terminal facilities are privately owned buildings on airport lease lots, owned, operated, and maintained by the individual air carriers. The buildings are old, in a state of disrepair, and were not originally sized to accommodate TSA screening facilities required under CFR Part 139 certificated operations. Retrofits often result in inadequate passenger waiting space on either side of the screening facilities.

The existing terminal facility for Alaska Airlines is a two-story, 9,450 square foot building that also houses a cargo warehouse. The building was previously shared with Ravn Alaska and indicated on the Land Occupancy Drawing as owned by Peninsula Airways. The Alaska aviation market is highly volatile. After bankruptcy, Ravn Alaska has discontinued service, and the building was sold to Alaska Airlines. Improvements are currently planned for the building, including baggage screening, but no expansion is planned. A tent is usually set up outside for passenger waiting after security screening.

A shared terminal facility is depicted for the ultimate Dillingham Airport configuration off the expanded apron, but a funding source has not been identified. A shared terminal facility could accommodate space for TSA baggage and passenger screening, pre- and post-screening waiting areas, and house multiple air carriers.

### 8.2.3 Expanded Terminal Apron

The existing Terminal Apron is narrow and congested under peak operations. Lease lots occupy approximately a third of the apron space and there is insufficient space for large aircraft parking within the lease lots. During increased summer traffic, transient aircraft park on the north edge of the apron near the Taxiway C entrance to the General Aviation Apron.

After the runway shift to correct the RSA width deficiency, the apron and parallel taxiway will be at the minimum offset from the runway of 400 feet. Ideally, the apron would be expanded to the west, but this would require demolition of the airport buildings and infrastructure. An apron expansion to the north is proposed based on site constraints to provide more space for a shared terminal facility and transient aircraft parking.

### 8.2.4 No-Taxi Islands / Offset Taxiway

The existing Taxiways A and B lead directly from the Terminal Apron onto the runway. To decrease the potential for runway incursions, airport geometry should not allow straight access from the apron onto the runway. No-taxi islands (Figure 45) were modeled within the existing apron but were determined to detract too much space from the already congested apron. Instead, Taxiways A and B will be demolished and a new taxiway added off the planned parallel taxiway, offset from the apron in the ultimate airport configuration (Figure 46). This geometry will give aircraft operators a better indication that they are diverging from the apron and entering a taxiway leading to the runway.

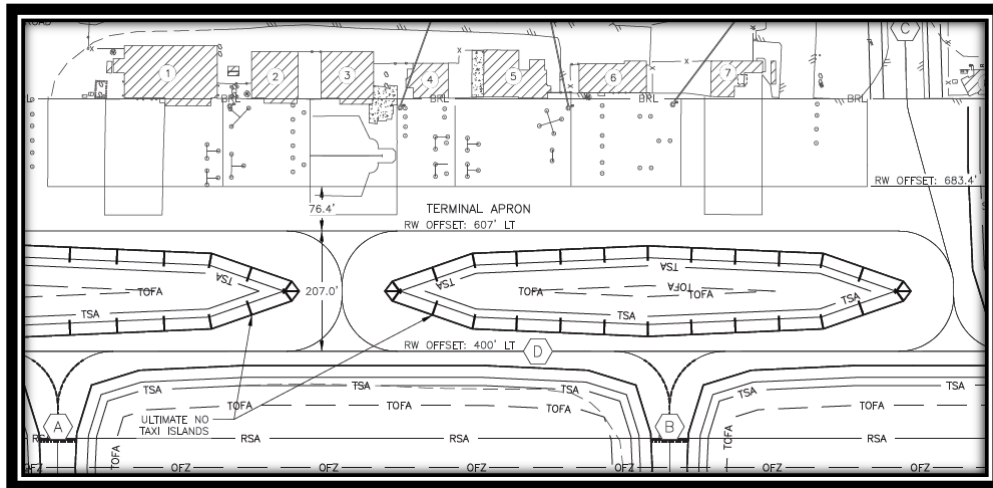

Figure 45: No-Taxi Islands



Figure 46: Taxiway Offset from Apron

### 8.2.5 Turnarounds

Pavement showing distress has been observed on the north end of the runway. This is a result of locked wheel turns from large aircraft turnarounds on the runway. Additional paved surface is required to allow for turnarounds and to prevent damage to runway pavement. Elephant ears were considered but determined to be not ideal. Instead, a turnaround comprised of a two-taxiway loop with unpaved infield will be added. The turnaround was designed to be in line with the ultimate parallel taxiway. It is

anticipated that the turnaround would be constructed first and incorporated into the parallel taxiway at a later date. The turnaround was added to the north end of the runway, only because that is where the pavement distress from locked wheel turns was observed. Runway 1 is the predominant runway direction due to the instrument landing system. The south leg of the full-length parallel taxiway will ultimately provide for turnarounds at the south runway end which is close to the apron.

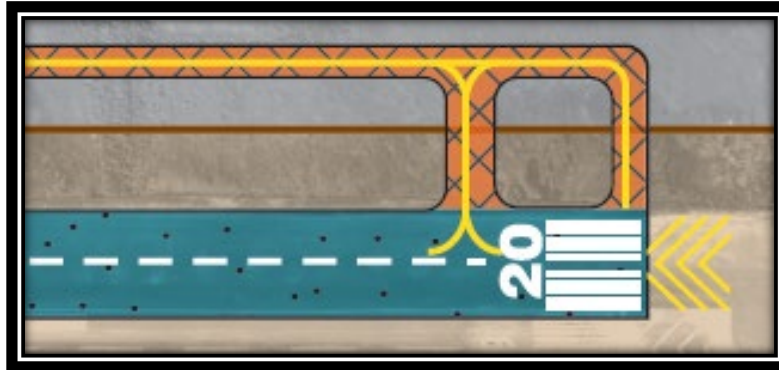

Figure 47: Turnaround Taxiways

## 9.0 Airport Layout Plan

An Airport Layout Plan (ALP) was developed in conjunction with the Airport Master Plan. It depicts the existing and ultimate configuration of the Dillingham Airport based on the recommended alternative. Figure 48 provides a general overview. See Attachment A: *Airport Layout Plan* for the full ALP.

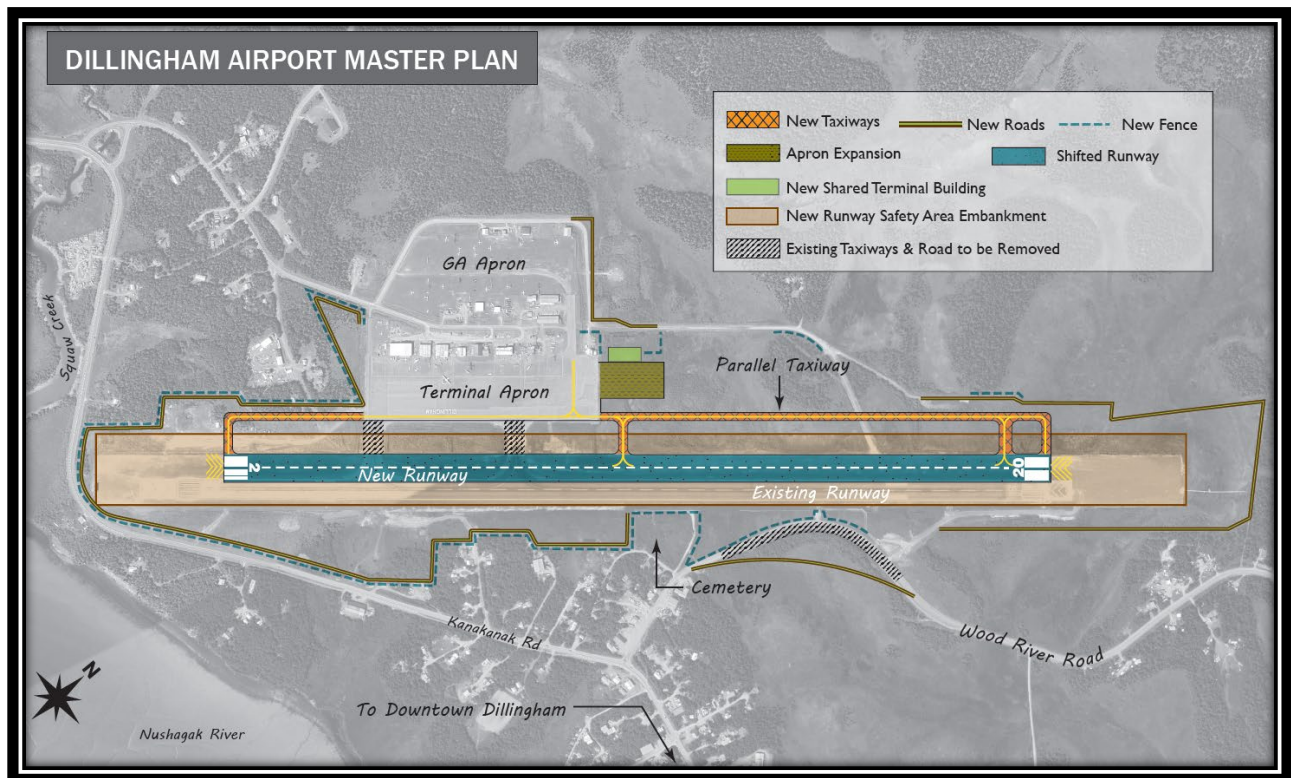

Figure 48: Proposed Future Layout

## 10.0 Financial Feasibility Analysis

This chapter discusses an analysis of DLG’s funding sources as well as proposed uses via a Capital Improvement Program (CIP) to implement the recommended alternative depicted in the ALP. The CIP needs to be based on reasonably foreseeable funding availability to ensure that the recommended alternative is implementable, financially.

### 10.1 Sources of Funding

Available funding sources for DLG include revenue generating options to support capital project costs and the funding mechanisms typically used in Alaska to meet capital requirements, such as federal and state programs, and municipal contributions.

#### 10.1.1 Airport Revenue

The Federal Aviation Administration requires airports to remain as self-sustaining as possible. In general, rural airports owned and operated by Alaska Department of Transportation and Public Facilities (DOT&PF) are not self-sustaining. Maintenance and operating costs are offset by the state’s general fund when needed.

Lease income accounts for virtually all DOT&PF revenue associated with DLG operations. Consistent with other state-operated rural Alaska airports, DOT&PF charges no airport user or landing fees at DLG. DLG cash flows are not considered a credible source of capital funding for projects described in this Master Plan. Operating expenses routinely exceed revenue at DLG. In State Fiscal Year (SFY) 2020, operating revenue of \$383,839 and expenses of \$955,895 contributed to a deficit of \$572,056.

#### 10.1.2 Federal Aviation Administration Airport Improvement Program

Federal funding for airports is managed by the FAA through the Airport Improvement Program (AIP). Funding is generated through the Airport and Airway Trust Fund, which was established by the Airport and Airway Revenue Act of 1970. Funding allocations are typically prioritized to enhance safety, security, capacity, and to mitigate environmental factors, including noise. This program will be the primary source of capital funding for projects described in this Master Plan, as allocated through the State of Alaska Rural Airport Improvement Program, as described below.

Federal AIP grant funding includes two major categories: entitlements and discretionary funding. Annually, about two-thirds of total AIP funding is allocated to airports via entitlement grants. Discretionary funding composes the remaining one-third of annual AIP funding and is set aside for specific projects based on their overall importance and priority. AIP grants are designed to be used for eligible capital projects, equipment, and certain types of planning and environmental studies. AIP grants cannot be used for airport operating expenses or debt financing.

**Table 43: Examples of Eligible vs. Ineligible AIP Projects**

Eligible Projects	Ineligible Projects
Runway construction/rehabilitation	Maintenance equipment and vehicles
Taxiway construction/rehabilitation	Office and office equipment
Apron construction/rehabilitation	Fuel farms*
Airfield lighting	Landscaping
Airfield signage	Artworks
Airfield drainage	Aircraft hangars*
Land acquisition	Industrial park development
Weather observation stations (AWOS)*	Marketing plans
NAVAIDs such as REILs and PAPIs	Training
Planning studies	Improvements for commercial enterprises
Environmental studies	Maintenance or repairs of buildings
Safety area improvements	
Airport layout plans (ALPs)	
Access roads only located on airport property	
Removing, lowering, moving, marking, and lighting hazards	
Glycol Recovery Trucks/Glycol Vacuum Trucks**	

Source: FAA AIP.

\*May be eligible. Contact with local Airport District or Regional Office is required.

\*\*To be eligible, vehicles must be owned and operated by the Airport and meet the Buy American Preference specified in the AIP grant.

Nationally, AIP grants are programed to cover 90% of AIP eligible project costs, with the sponsor responsible for the remaining 10%. In Alaska, AIP grants are programed to cover 93.75% of AIP-eligible project costs, with the sponsor responsible for the remaining 6.25%. Project eligibility determinations are based on the FAA AIP Handbook, FAA Order 5100.38D, Change 1 (and as revised).

To be eligible for AIP funding, an airport must be included in the National Plan of Integrated Airport Systems (NPIAS). As of the 2021-2025 NPIAS Report, the FAA classified DLG as a Commercial Service Primary Non-hub airport. This category indicates DLG is a publicly owned airport with at least 2,500 annual enplanements and schedule air carrier service receiving less than 0.05% of US commercial enplanements.

DOT&PF is the sponsor of many of Alaska's rural airports and is responsible for administering AIP grants for NPIAS airports classified as non-primary commercial service, reliever, and general aviation. DLG is allocated \$1 million in FAA AIP primary entitlement funding each year. In Alaska, primary entitlement funds are pooled each year to fund prioritized projects within the state's Rural Airport Program, described in later sections of this document. DOT&PF also applies for additional FAA discretionary funding to fund projects in the Rural Airport System AIP Spending Plan; however, federal funding for primary airports in the NPIAS continues to be allocated and administered by the FAA.

### 10.1.3 Passenger Facility Charges

Airports operated by public agencies may participate in the FAA Passenger Facility Charge (PFC) program in which airports collect fees up to \$4.50 per eligible passenger to fund FAA-approved projects that enhance safety, security, or capacity; abate aircraft noise; or increase air carrier competition. PFC revenues may be used to pay for all or part of FAA-approved project costs; pay debt service and financing costs associated with bond issuance; in addition to AIP grant funds; and as AIP matching grant funds. PFC charges are collected by air carriers at time of ticket sale and remitted to the airport, with carriers retaining a fee of \$0.11 per PFC collected.

Primary entitlement funds are reduced based on the level of approved PFC for airports classified as large or medium primary hubs. Since DLG is designed as a non-hub airport, the airport's passenger entitlement grants would not be subject to this reduction.

Based on 2019 passenger volume and the maximum PFC of \$4.50 (less carrier retention), implementing a PFC at DLG could result in about \$350,000 in funding. While the addition of a PFC is not expected to generate sufficient revenue to fund projects in this Master Plan's CIP, fees could provide a supplemental source of revenue to offset capital costs.

The State of Alaska has not previously applied for a PFC at DLG.

### 10.1.4 State of Alaska Rural Airport Improvement Program

The State of Alaska owns and operates 235 airports within the Rural Airport System. DOT&PF receives federal grant funding through the FAA AIP described previously. Most airfield capital improvements, property acquisition, and professional services (such as planning, surveying, and design) are eligible. All projects must meet FAA regulatory and policy requirements regarding adequate justification, reasonableness, and compliance with FAA design standards.

DOT&PF maintains the Rural Airport System AIP Spending Plan, which outlines projects to be funded at state-owned rural airports over a five-year period. The spending plan is developed according to the following process:

- Proposed airport project needs are collected and entered into the DOT&PF's Alaska Airport Needs Directory and AIP Needs List through input from aviation interests, community representatives, FAA staff, the Alaska State Legislature and DOT&PF staff.
- Regional planning sections perform an initial evaluation of projects based on AIP eligibility, aviation criteria, and guidance. Detailed project nomination sheets and estimates are prepared for eligible construction projects.
- Project nominations go through a regional screening and are evaluated by the Aviation Project Evaluation Board (APEB). This board scores project nominations for rural airports statewide. Airfield improvements are ranked on 16 criteria including safety, health and quality of life, economic development, maintenance and operations issues, local capital contribution to project cost, and others. Building improvements are ranked on 8 criteria including structural safety, weather conditions, equipment needs, and others.



- The highest scoring projects are then ranked competitively, with those receiving the highest ranking considered for inclusion in the AIP Spending Plan. In some cases, projects are included in the Spending Plan based on federal requirements from the FAA or Transportation Security.

Capital projects described in the Master Plan will be evaluated through the APEB process.

### 10.1.5 Landing Fees

Airports often charge landing fees based on aircraft certified maximum gross take-off weight (CMGTW). The State of Alaska currently does not charge landing fees at any of the State's primary Part 139 certified airports. A study commissioned by DOT&PF examined the potential landing fee revenue at select rural airports based on a \$2.00 per 1,000-pound fee. This study estimated theoretical landing fee revenue of \$246,580 at DLG based on airport activity in SFY2012. The study also concluded that "the residential population would bear most of the burden of any carrier business model changes adopted as a result of landing fee implementation".<sup>63</sup>

The addition of a landing fee is not expected to generate sufficient revenue to fund projects in this CIP; however, fees could provide a supplemental source of revenue to offset capital costs.

### 10.1.6 Municipal Contributions

Municipal governments may contribute financially to the non-FAA share of AIP-eligible airport improvement projects. Contributions may be direct financial funding using the municipality's revenue or participation in a loan agreement to secure financing. Other municipal contributions that may be used include land donations or tax incentives. Local capital contributions positively impact project scores nominated to the APEB and may influence a project's ranking in the statewide AIP Spending Plan. Local capital contributions are not considered a credible source of capital funding for projects described in this Master Plan.

## 10.2 Capital Improvement Program

Table 44 describes each project required per this Master Plan's CIP for the recommended alternative. The estimated cost for each of the recommended airport improvements reflects the probable implementation cost for the project. In addition to the estimated construction costs, anticipated fees for design, inspection, permitting, surveying, testing, and administration were included in the overall estimate where applicable. Each project cost is presented in 2021 dollars and, therefore, does not reflect unanticipated increases in labor and material costs. A contingency was added to the overall costs to account for unforeseen changes in cost.

The total cost of all projects is estimated at \$68,971,944, which include all studies, infrastructure improvements, and proposed construction costs necessary to achieve the alternative recommended in the Master Plan. This CIP does not assume how financially feasible it will be for the State to undertake the projects or whether funding will be available. All the projects are considered to be FAA AIP-eligible, and, therefore, costs are split between the Federal AIP (93.75%) and State portion (6.25%). Eligibility can

---

<sup>63</sup> State of Alaska Department of Transportation & Public Facilities. *Landing Fee Report*. December 2013.

be subject to change per FAA AIP requirements. Based on 2021 dollars, the portion that is state match is estimated to be about \$4.3 million.

**Table 44: Capital Improvement Program**

Project	2021 Cost Estimate	Federal AIP	State
Design	\$4,743,813	\$4,447,325	\$296,488
ROW	\$5,804,000	\$5,441,250	\$362,750
Obstruction Removal & Clearing	\$1,116,000	\$1,046,250	\$69,750
Utilities	\$1,525,000	\$1,429,688	\$95,313
RW & RSA Construction	\$35,789,501	\$33,552,657	\$2,236,844
Airport Lighting	\$1,421,940	\$1,333,069	\$88,871
Approach Lights & Nav aids	\$1,278,690	\$1,198,772	\$79,918
Road Realignment	\$503,000	\$471,563	\$31,438
Service Road Construction & Security Fencing	\$16,790,000	\$15,740,625	\$1,049,375
<b>Total</b>	<b>\$68,971,944</b>	<b>\$64,661,198</b>	<b>\$4,310,747</b>

Source: R&M Consultants and McKinley Research Group calculations.

## **Appendix A: Airport Layout Plan**

Designed By: MM/RLC  
 Drawn By: MM/RLC  
 Checked By: CLB  
 Date Plotted: 2/17/2023, 12:32 PM  
 Plot Number: COVER  
 File Name: Z:\projects\2020\_01 DOI\_C.B.G.AMP\post\Civil\ACAD\ALP\ALP-DLG-cover.dwg

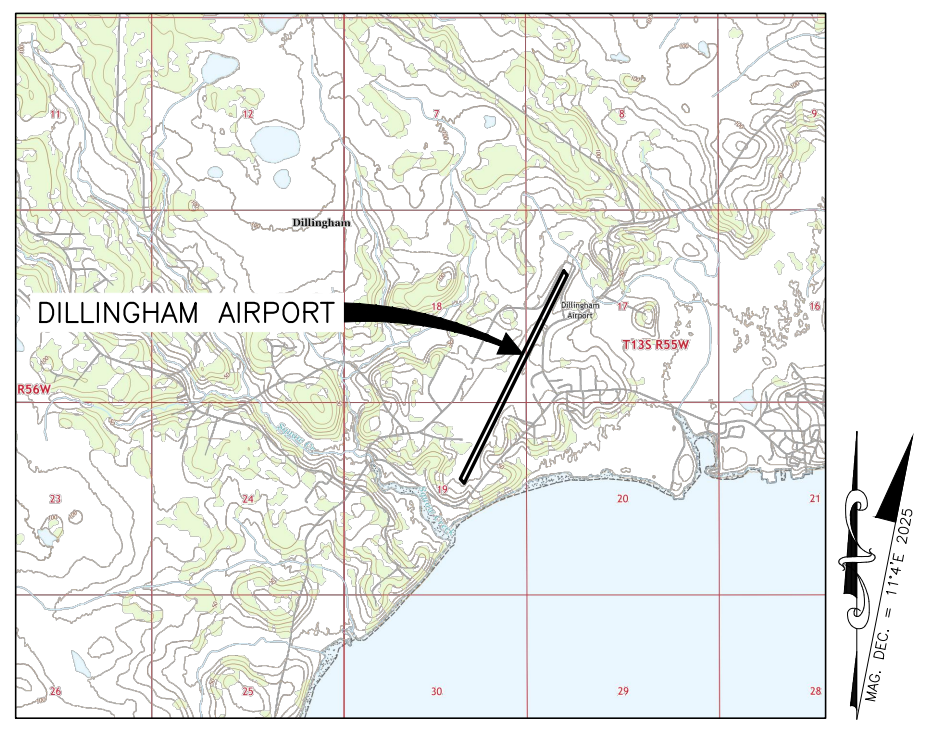

# DILLINGHAM AIRPORT AIRPORT LAYOUT PLAN

## DILLINGHAM, ALASKA

ITEM	LEGEND	
	EXISTING	ULTIMATE
AIRCRAFT TIEDOWN		
AIRPORT REFERENCE POINT (A.R.P.)		
ANTENNA		
APPROACH SURFACE		
BUILDINGS		
BUILDING RESTRICTION LINE		
DEPARTURE SURFACE		
FENCE		
LOCALIZER CRITICAL AREA		
ODAL		
PAPI		
PROPERTY LINE		
ROADWAYS (GRAVEL)		
ROADWAYS (PAVED)		
ROTATING BEACON		
RUNWAY OBJECT FREE AREA		
RUNWAY OBSTACLE FREE ZONE		
RUNWAY PROTECTION ZONE		
RUNWAY SAFETY AREA		
SEGMENTED CIRCLE		
SURVEY MONUMENT		
TAXIWAY SAFETY AREA		
TAXIWAY OBJECT FREE AREA		
THRESHOLD LIGHTS		
THRESHOLD SITING SURFACE		
TOPOGRAPHIC CONTOURS		
TREELINE		
UTILITY POLE		
VASI		
WATER BODY		
WEATHER STATION		
WEATHER STATION CRITICAL AREA		
WIND CONE		

DRAWING INDEX	
SHT #	TITLE
1	COVER AND SHEET INDEX
2	AIRPORT DATA
3	WIND DATA
4	EXISTING LAYOUT
5	EXISTING OFA AND OFZ PENETRATIONS
6	EXISTING OFA AND OFZ PENETRATION TABLES
7	ULTIMATE LAYOUT
8	ULTIMATE OFA AND OFZ PENETRATIONS
9	ULTIMATE OFA AND OFZ PENETRATION TABLES
10	EXISTING TERMINAL PLAN
11	ULTIMATE TERMINAL PLAN
12	EXISTING INNER PORTION OF RW 1-19 APPROACH SURFACE
13	EXISTING INNER PORTION OF APPROACH SURFACE OBSTRUCTION TABLES
14	ULTIMATE INNER PORTION OF RW 2-20 APPROACH SURFACE
15	ULTIMATE INNER PORTION OF APPROACH SURFACE OBSTRUCTION TABLES
16	EXISTING RW 1-19 DEPARTURE SURFACE
17	ULTIMATE RW 2-20 DEPARTURE SURFACE
18	RUNWAY PROFILES
19	AIRPORT AIRSPACE (FAR PART 77)
20	PROPERTY MAP
21	LAND USE

BY	DATE	REVISION

**APPROVED:** \_\_\_\_\_ **DATE:** \_\_\_\_\_  
**LUKE BOWLAND, P.E.** PRECONSTRUCTION ENGINEER  
**RECOMMENDED:** \_\_\_\_\_ **DATE:** \_\_\_\_\_  
**JENELLE BRINKMAN, P.E.** AVIATION DESIGN GROUP CHIEF  
 AIRPORT LAYOUT PLAN CONDITIONAL APPROVAL SUBJECT TO  
 ALP APPROVAL LETTER DATED \_\_\_/\_\_\_/\_\_\_  
 FAA AIRSPACE REVIEW NUMBER: \_\_\_\_\_  
**DATE:** \_\_\_\_\_  
**FAA, AIRPORTS DIVISION ALASKAN REGION, AAL-**

**STATE OF ALASKA**  
**DEPARTMENT OF TRANSPORTATION**  
**AND PUBLIC FACILITIES**  
**CENTRAL REGION**

**DILLINGHAM AIRPORT**  
 DILLINGHAM, ALASKA  
 AIRPORT LAYOUT PLAN  
 COVER AND SHEET INDEX

**DATE:** 2/17/2023  
**SHEET:** 1 OF 21

Date Plotted: 2/17/2023, 12:33 PM  
 Plot Number: ALP  
 File Name: Z:\projects\2020\_01 DOI\_C.B.G.AMP\p0201\ACAD\ALP\ALP-DLG-Airport-Data.dwg  
 Designed By: MW/RLC  
 Drawn By: MW/RLC  
 Checked By: CUB

AIRPORT DATA TABLE		
ITEM	EXISTING	ULTIMATE
ICAO IDENTIFIER	PADL	PADL
NATIONAL AIRPORT IDENTIFIER	DLG	DLG
FAA SITE NUMBER	50153.*A	50153.*A
AIRPORT ELEVATION NAVD88	82.0'	81.5'
AIRPORT REFERENCE CODE	C-III	C-IV
CRITICAL AIRCRAFT OR AIRCRAFT GROUP	C-III	C-IV
MEAN MAX. TEMPERATURE, HOTTEST MONTH	62.5°F, JULY	
MAGNETIC DECLINATION, YEAR, RATE OF CHANGE (MODEL, SOURCE)	11°4' E, 2025, 0°14' W PER YEAR (WMM-2020, <a href="https://www.ngdc.noaa.gov/geomag/calculators/magcalc.shtml#declination">https://www.ngdc.noaa.gov/geomag/calculators/magcalc.shtml#declination</a> )	
AIRPORT AND TERMINAL NAVIGATIONAL AIDS (OWNERSHIP)	VOR (FAA), DME (FAA), NDB (FAA), LOC (FAA), SEGMENTED CIRCLE (DOT&PF), ROTATING BEACON (DOT&PF)	VOR (FAA), DME (FAA), NDB (FAA), LOC (FAA), SEGMENTED CIRCLE (DOT&PF), ROTATING BEACON (DOT&PF)
MISCELLANEOUS FACILITIES	WEATHER STATION, SAWS, WINDCONE	WEATHER STATION, SAWS, WINDCONE
NPIAS SERVICE LEVEL	COMMERCIAL SERVICE - PRIMARY, NONHUB	COMMERCIAL SERVICE - PRIMARY, NONHUB
STATE EQUIVALENT SERVICE ROLE	REGIONAL HUB	REGIONAL HUB

RUNWAY DATA TABLE		
ITEM	EXISTING	ULTIMATE
RUNWAY IDENTIFIER	1 / 19	2 / 20
RUNWAY TYPE (UTILITY OR OTHER THAN UTILITY)	OTHER THAN UTILITY	OTHER THAN UTILITY
FAR PART 77 APPROACH CATEGORY (V, NPI, P)	NPI	NPI
FAR PART 77 VISIBILITY MINIMUM	1 SM	1 SM
FAR PART 77 APPROACH SURFACE SLOPE	34:1	34:1
APPROACH TYPE (VIS, NPA, APV(NP) APV(P), PREC)	NPA	NPA
THRESHOLD SITING SURFACE SLOPE	20:1	20:1
DEPARTURE SURFACE (Y/N)	Y	Y
RUNWAY DESIGN CODE (RDC)	C-III-5000	C-IV-5000
APPROACH REFERENCE CODE (APRC)	D/IV/4000	D/IV/4000 / D/V/4000
DEPARTURE REFERENCE CODE (DPRC)	D/VI	D/IV / D/V
RUNWAY SURFACE	ASPHALT	ASPHALT
SURFACE TREATMENT	GROOVED	GROOVED
GEAR CONFIG/PAVE STRENGTH (X1000 LBS)	SW 116, DW 186, DTW 300, DDTW 726	SW 116, DW 186, DTW 300, DDTW 726
PAVEMENT STRENGTH (PCR)	1132/F/C/X/T	1132/F/C/X/T
DESIGN AIRCRAFT (IF >60,000 LBS)	C-III	C-IV
MAXIMUM ELEVATION (NAVD88)	82.0'	81.5'
TOUCHDOWN ZONE ELEVATION (NAVD88)	81.5' / 81.3'	81.5' / 81.3'
EFFECTIVE GRADE	0.26%	0.21%
MEAN GEODETIC AZIMUTH (DEC, CW FROM NORTH)	26.49°	26.49°
RUNWAY DIMENSIONS	150' X 6,400'	150' X 6,000'
RUNWAY SAFETY AREA (RSA)	350' X 8,000'	500' X 8,000'
RSA LENGTH BEYOND DEPARTURE END	1,000' / 600'	1,000'
RSA LENGTH PRIOR TO THRESHOLD	600' / 1,000'	1,000'
RUNWAY OBJECT FREE AREA (OFA)	800' X 8,400'	800' X 8,000'
ROFA LENGTH BEYOND DEPARTURE END	1,000'	1,000'
ROFA LENGTH PRIOR TO THRESHOLD	1,000'	1,000'
RUNWAY OBSTACLE FREE ZONE (OFZ)	400' X 6,800'	400' X 6,400'
INNER APPROACH OBSTACLE FREE ZONE (OFZ)	N/A / 400' X 1,500'	N/A / 400' X 1,500'
PRECISION APPROACH OBSTACLE FREE ZONE (POFZ)	N/A	N/A
RUNWAY PROTECTION ZONE (RPZ)	1,700' X 500' X 1,010'	1,700' X 500' X 1,010'
RUNWAY LIGHTING	HIRL	HIRL
RUNWAY MARKING TYPE (V, NPI, P)	NPI	NPI
RUNWAY NAVIGATIONAL AIDS	PAPI / VASI, ODALS	PAPI / VASI, ODALS
AERONAUTICAL SURVEY TYPE REQUIRED	NVGS	NVGS

DECLARED DISTANCES				
RUNWAY	TORA	TODA	ASDA	LDA
EXISTING	1	6,400'	6,400'	6,400'
	19	6,400'	6,400'	6,400'
ULTIMATE	2	6,000'	6,000'	6,000'
	20	6,000'	6,000'	6,000'

**NOTES:**

- THE HORIZONTAL COORDINATE SYSTEM FOR THIS ALP IS NAD83(2011) ALASKA STATE PLANE ZONE 6, U.S. SURVEY FEET. THE VERTICAL DATUM FOR THIS ALP IS NAVD88(GEOID 12B).
- RW 19 ODALS REQUIRE INNER APPROACH OFZ (SEE AC 150/5300-13B, PARAGRAPH 3.11.3 / FIGURE 3-20).
- THE EXISTING RUNWAY 1/19 IS RE-DESIGNATED TO 2/20 IN THE ULTIMATE CONFIGURATION BASED ON THE 2024 MAGNETIC DECLINATION.
- REPORTED STANDARDS ARE BASED ON AC 150/5300-13B.

AIRPORT CONTROL								
PID	DESIGNATION	LATITUDE	LONGITUDE	ELLIPSOID HEIGHT	NORTHING	EASTING	ELEVATION	DESCRIPTION
DN1839	DLG A	59°02'42.23" N	158°30'27.75" W	121.0'	1843262.5569'	1544815.0895'	77.3'	PACS
DN1952	DLG B	59°02'25.76" N	158°30'44.12" W	116.6'	1841597.0780'	1543945.9016'	72.9'	SACS
DN1953	DLG C	59°03'22.13" N	158°29'38.76" W	115.6'	1847293.4248'	1547407.1808'	72.0'	SACS

GEOGRAPHIC COORDINATES								
ITEM	EXISTING LATITUDE	EXISTING LONGITUDE	EXISTING STATION	EXISTING ELEVATION	ULTIMATE LATITUDE	ULTIMATE LONGITUDE	ULTIMATE STATION	ULTIMATE ELEVATION
ARP	59°02'40.83" N	158°30'19.85" W	-	-	59°02'43.25" N	158°30'20.70" W	-	-
RW 1 THRESHOLD	59°02'12.61" N	158°30'47.13" W	11+00.00	74.4'	-	-	-	-
RW 19 THRESHOLD	59°03'09.04" N	158°29'52.56" W	75+00.00	64.9'	-	-	-	-
RW 2 THRESHOLD	-	-	-	-	59°02'16.80" N	158°30'46.28" W	15+00.00	75.1'
RW 20 THRESHOLD	-	-	-	-	59°03'09.70" N	158°29'55.11" W	75+00.00	69.2'

TAXIWAY DATA TABLE						
EXISTING						
TAXIWAY #	TW A	TW B	TW C	TW D	TW E	TW F
AIRPLANE DESIGN GROUP	III	III	II	-	-	-
TAXIWAY DESIGN GROUP	3	3	3	-	-	-
TAXIWAY SURFACE	ASPHALT	ASPHALT	GRAVEL	-	-	-
TAXIWAY DIMENSIONS	90' X 515'	90' X 515'	50' X 1,750'	-	-	-
SHOULDER WIDTH	20'	20'	20'	-	-	-
SAFETY AREA (TSA) WIDTH	118'	118'	79'	-	-	-
EDGE SAFETY MARGIN (TESM)	10'	10'	-	-	-	-
OBJECT FREE AREA (TOFA) WIDTH	171'	171'	124'	-	-	-
TAXIWAY LIGHTING	MITL	MITL	NONE	-	-	-
TAXIWAY MARKING	YES	YES	NONE	-	-	-
ULTIMATE						
AIRPLANE DESIGN GROUP	-	-	II	IV	IV	IV
TAXIWAY DESIGN GROUP	-	-	2	3	3	3
TAXIWAY SURFACE	-	-	GRAVEL	ASPHALT	ASPHALT	ASPHALT
TAXIWAY DIMENSIONS	-	-	35' X 1,750'	50' X 6,668'	50' X 400'	50' X 400'
SHOULDER WIDTH	-	-	20'	20'	20'	20'
SAFETY AREA (TSA) WIDTH	-	-	79'	171'	171'	171'
EDGE SAFETY MARGIN (TESM)	-	-	-	10'	10'	10'
OBJECT FREE AREA (TOFA) WIDTH	-	-	124'	259'	259'	259'
TAXIWAY LIGHTING	-	-	MITL	MITL	MITL	MITL
TAXIWAY MARKING	-	-	NONE	YES	YES	YES

NON-STANDARD CONDITIONS			
ITEM	STANDARD	EXISTING	ULTIMATE
RSA WIDTH	500'	350'	500'
RSA LENGTH BEYOND DEPARTURE END OF RW 19	1,000'	600'	1,000'
TAXIWAY A & B (WIDTH)	50'	90'	REMOVED
TAXIWAY C (WIDTH)	35'	50'	35'
RUNWAY LINE OF SIGHT	5' AT ANY POINT ON RW	DEFICIENT	SUFFICIENT W/ PARALLEL TAXIWAY

MODIFICATION OF STANDARDS					
ASN	DESCRIPTION	FAA STANDARDS	EXISTING CONDITION	PROPOSED ACTION	DATE APPROVED
	NONE				

STATE OF ALASKA DEPARTMENT OF TRANSPORTATION AND PUBLIC FACILITIES CENTRAL REGION		DATE:	2/17/2023
		SHEET:	2 OF 21
DILLINGHAM AIRPORT DILLINGHAM, ALASKA AIRPORT LAYOUT PLAN		AIRPORT DATA	
BY:	DATE:	REVISION:	

Designed By: MMW/RLC  
 Drawn By: MMW/RLC  
 Checked By: CUB

Date Plotted: 2/17/2023, 12:33 PM  
 Plot Number: WIND  
 File Name: Z:\projects\2020\_01\_D01\_C\_BLS\_AWP\plots\Civil\ACAD\ALP\ALP-DLG-Wind-Data.dwg

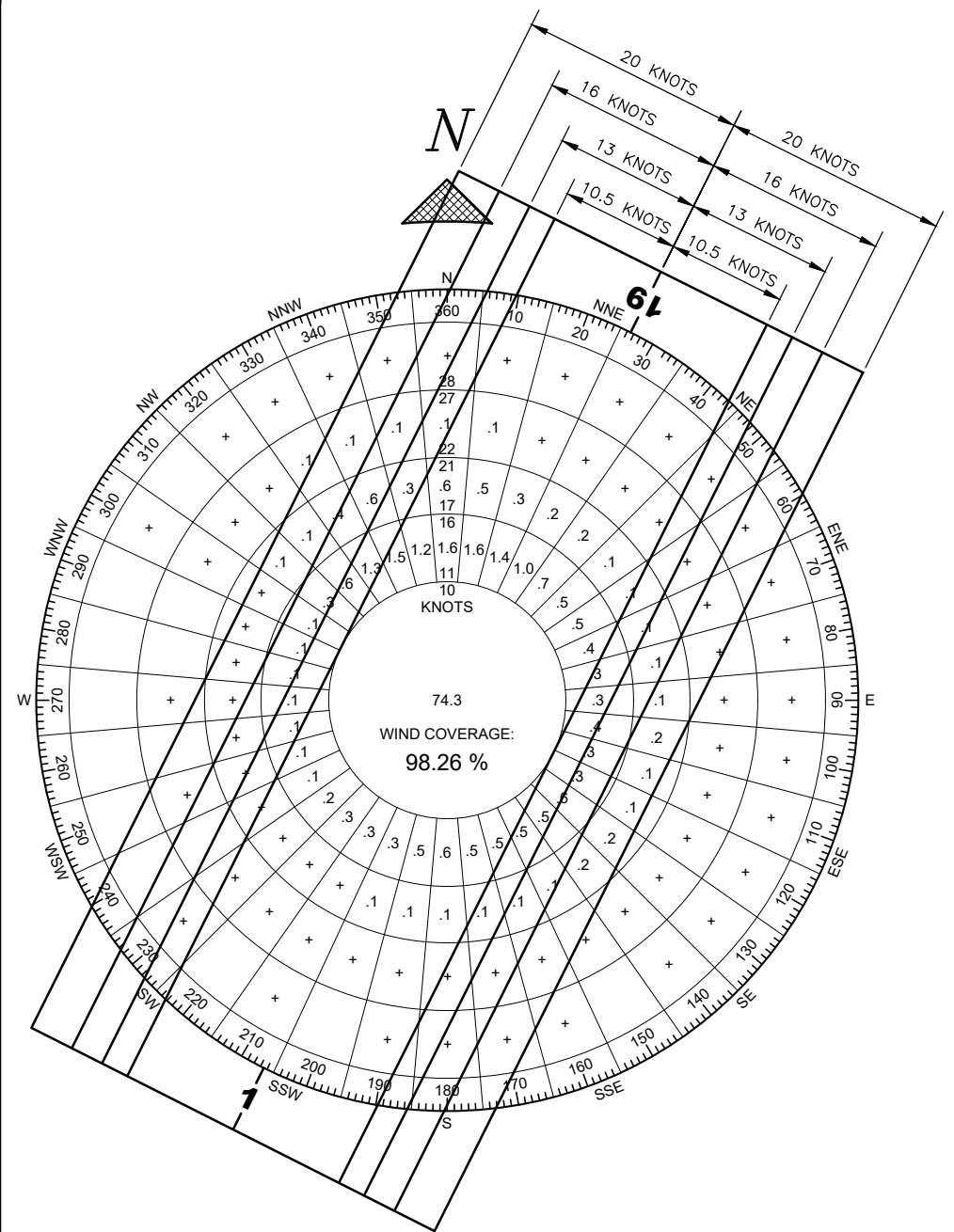

### WIND DATA

NOTE: WIND SPEED IS INDICATED IN KNOTS.

ALL WEATHER WIND DATA				
RUNWAY	10.5 KT	13 KT	16 KT	20 KT
RW 1/19	90.86%	95.07%	98.26%	99.57%

SOURCE: DILLINGHAM WIND DATA  
 FAA GIS NATIONAL CLIMATE DATA CENTER  
 MAY 6, 2021  
 PERIOD: 2011 - 2020

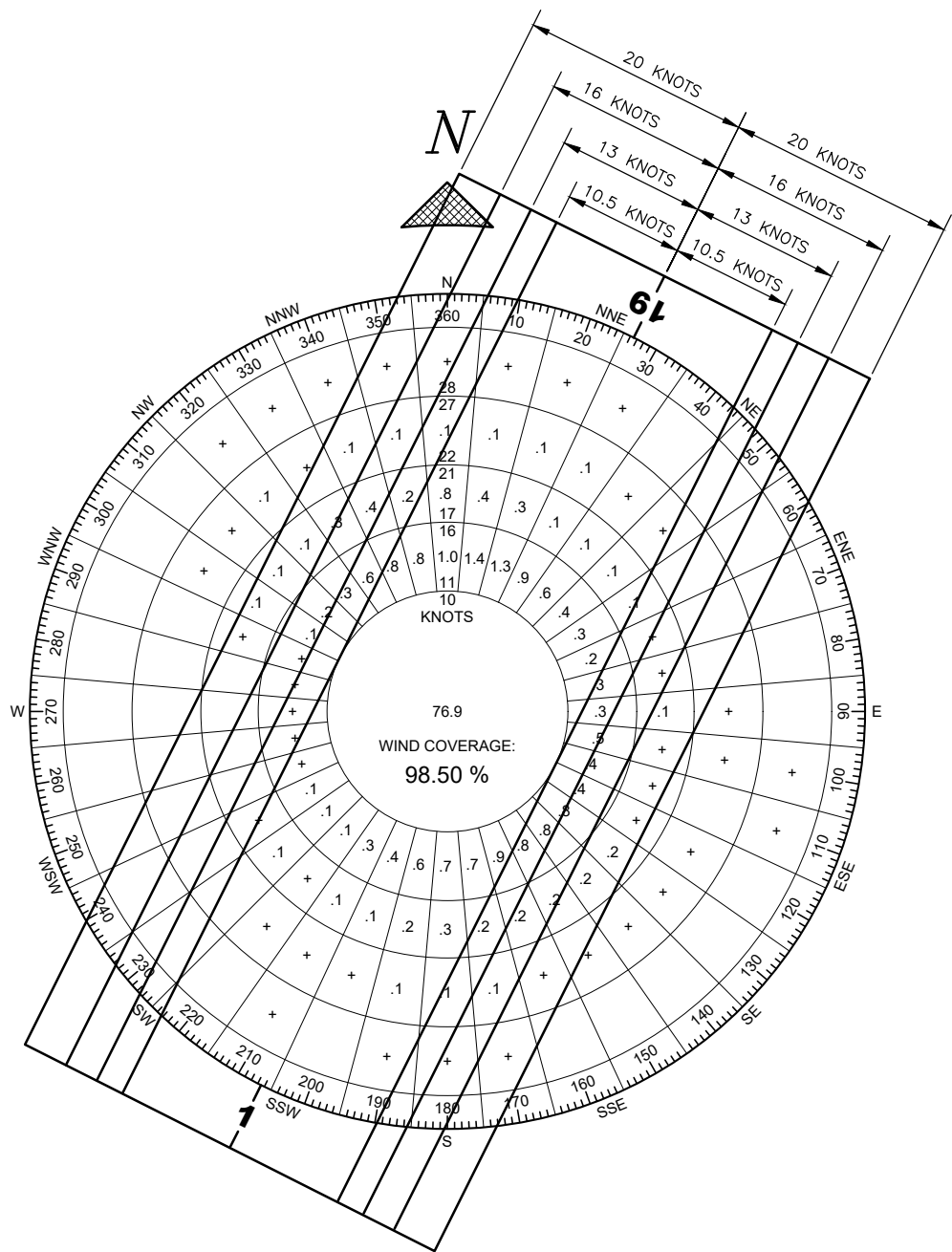

### WIND DATA

NOTE: WIND SPEED IS INDICATED IN KNOTS.

IFR WIND DATA				
RUNWAY	10.5 KT	13 KT	16 KT	20 KT
RW 1/19	91.72%	95.45%	98.50%	99.65%

SOURCE: DILLINGHAM WIND DATA  
 FAA GIS NATIONAL CLIMATE DATA CENTER  
 MAY 6, 2021  
 PERIOD: 2011 - 2020

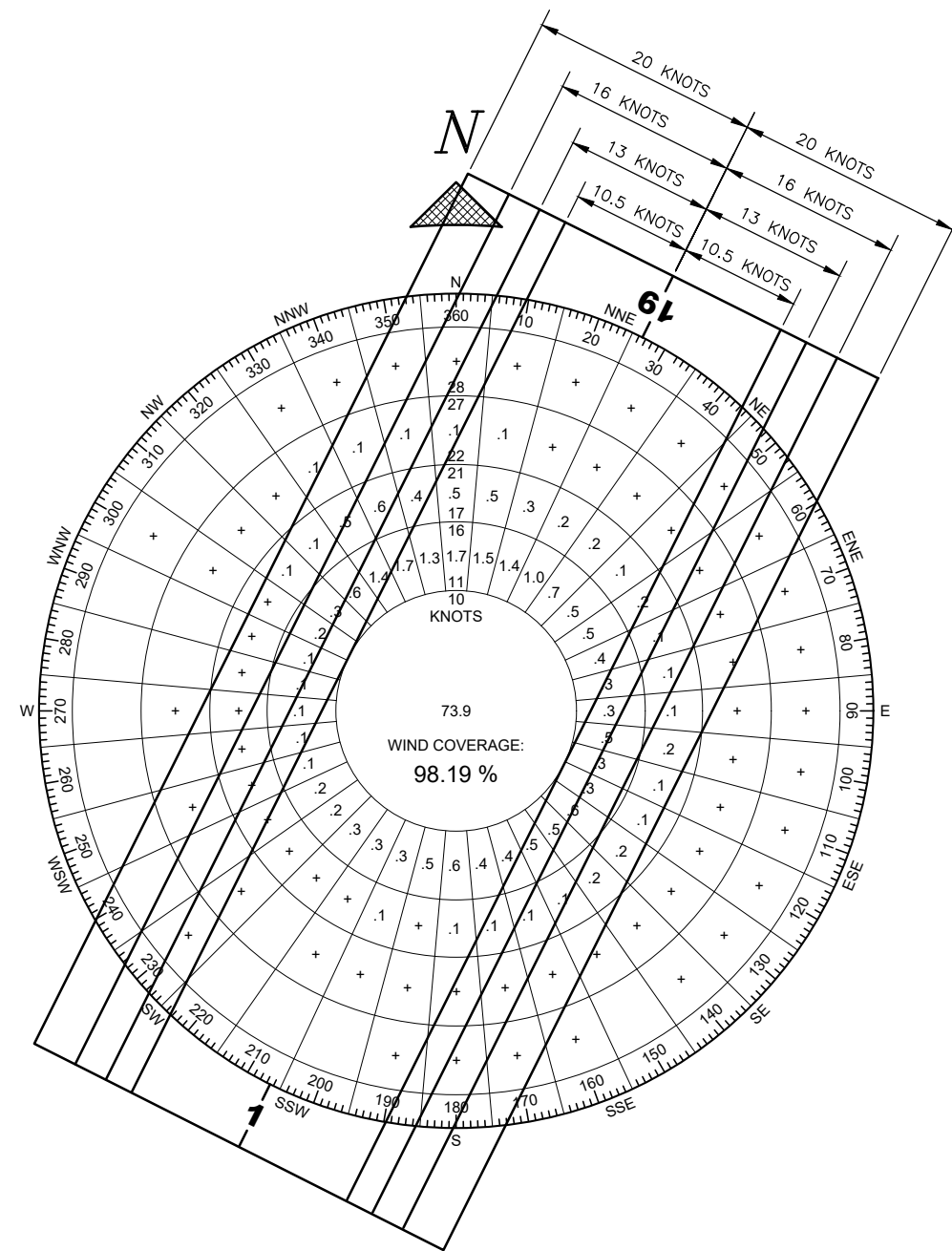

### WIND DATA

NOTE: WIND SPEED IS INDICATED IN KNOTS.

VFR WIND DATA				
RUNWAY	10.5 KT	13 KT	16 KT	20 KT
RW 1/19	90.57%	94.92%	98.19%	99.55%

SOURCE: DILLINGHAM WIND DATA  
 FAA GIS NATIONAL CLIMATE DATA CENTER  
 MAY 6, 2021  
 PERIOD: 2011 - 2020

BY	DATE	REVISION

**STATE OF ALASKA  
 DEPARTMENT OF TRANSPORTATION  
 AND PUBLIC FACILITIES  
 CENTRAL REGION**

**DILLINGHAM AIRPORT**  
 DILLINGHAM, ALASKA  
 AIRPORT LAYOUT PLAN

WIND DATA

DATE: 2/17/2023  
 SHEET: 3 OF 21

**NOTES:**

1. (X) TAXIWAY IDENTIFIER, SEE AIRPORT DATA SHEET.
2. SEE SHEET 5 FOR EXISTING OFA AND OFZ PENETRATIONS.
3. SEE EXISTING TERMINAL PLAN SHEET 10 FOR BUILDING DATA TABLE.
4. CEMETERY TO RUNWAY CENTERLINE SEPARATION DISTANCE IS 165'.

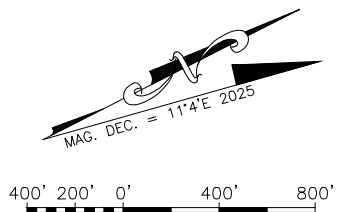

Date Plotted: 2/17/2023, 12:33 PM  
 Plot Number: E5311  
 File Name: Z:\proj\sect\2020\_01\DOI\_C.DLG AMP\proj\CA\111\ACAD\ALP\ALP-DLG-Ex1st1.dwg

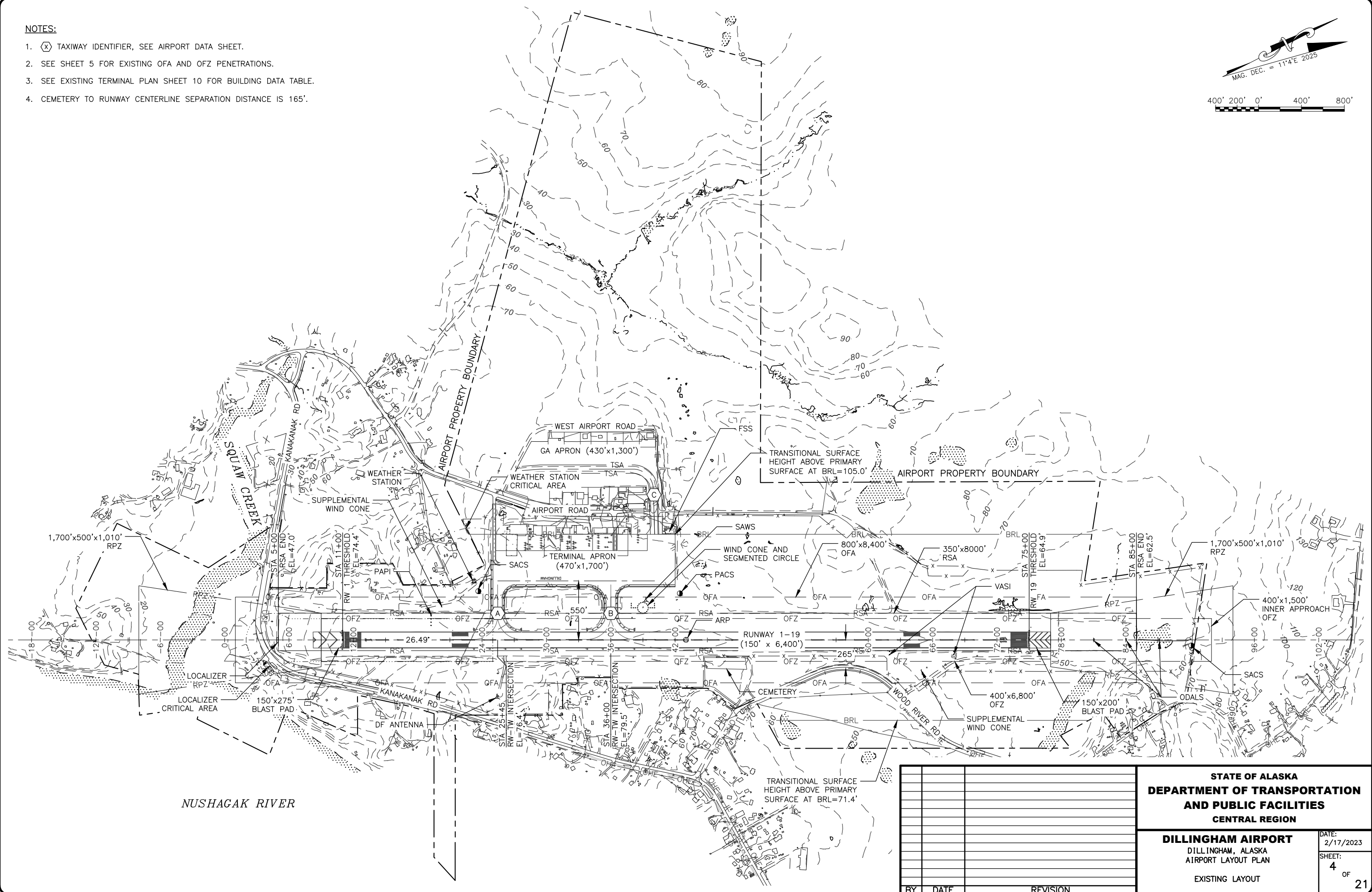

NUSHAGAK RIVER

BY	DATE	REVISION

**STATE OF ALASKA**  
**DEPARTMENT OF TRANSPORTATION**  
**AND PUBLIC FACILITIES**  
**CENTRAL REGION**

**DILLINGHAM AIRPORT**  
 DILLINGHAM, ALASKA  
 AIRPORT LAYOUT PLAN

EXISTING LAYOUT





DATE:  
2/17/2023  
SHEET:  
4  
OF  
21

Designed By: MMW/RLC  
 Drawn By: MMW/RLC  
 Checked By: CLB  
 Date Plotted: 2/17/2023, 12:33 PM  
 Layout Number: EX172  
 File Name: Z:\p03\proj\2020\_01\_D01\_C.BLG AMP\p03\CA\11\ACAD\VALP\ALP-DLG-EXIST.dwg

**NOTE:**

1. (X) TAXIWAY IDENTIFIER, SEE AIRPORT DATA SHEET.

**LEGEND**

	OFA TREE PENETRATIONS		OFZ TREE PENETRATIONS
	OFA TERRAIN PENETRATIONS		OFZ TERRAIN PENETRATIONS

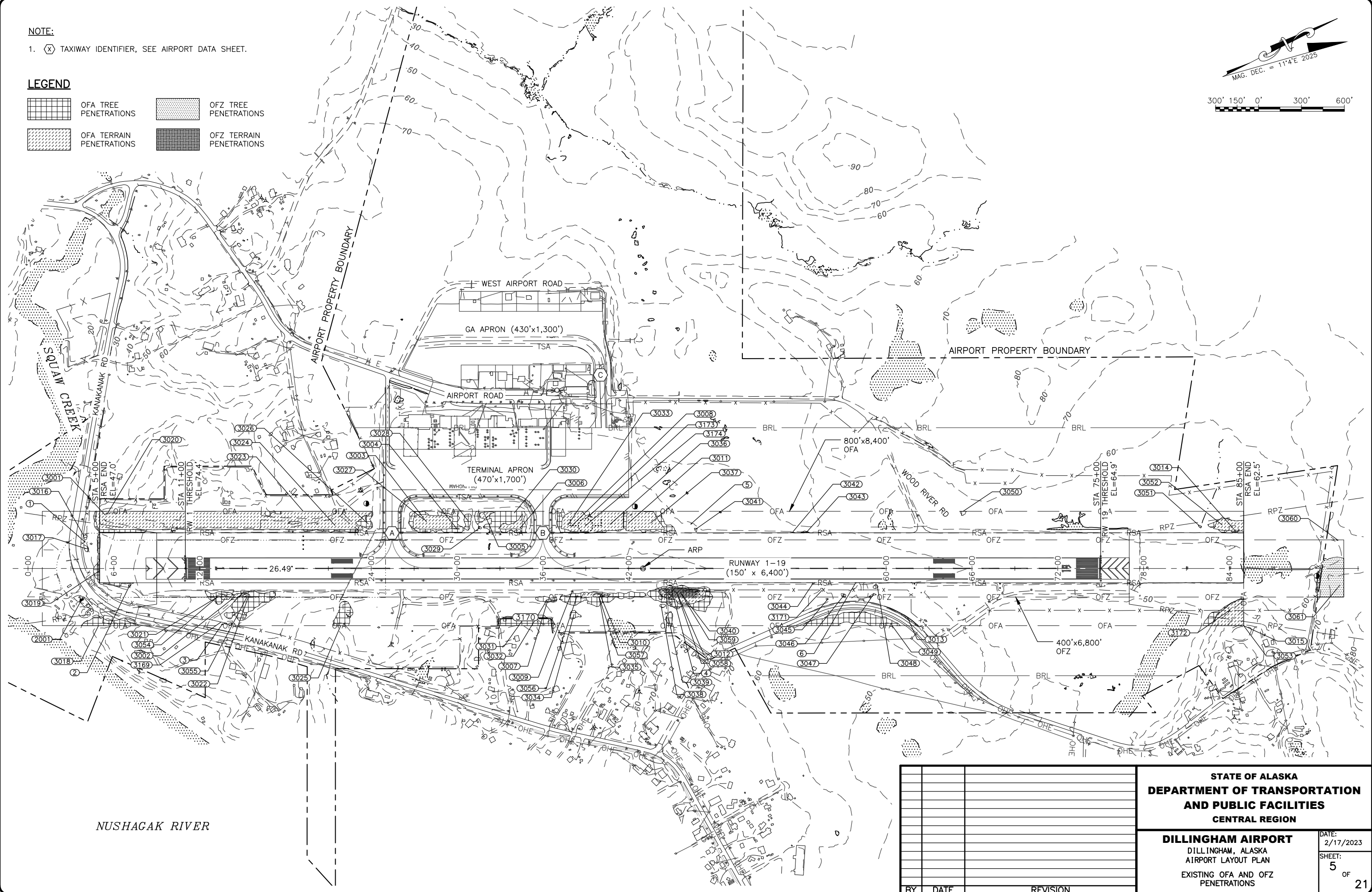
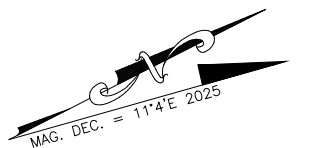

BY	DATE	REVISION

**STATE OF ALASKA  
DEPARTMENT OF TRANSPORTATION  
AND PUBLIC FACILITIES  
CENTRAL REGION**

**DILLINGHAM AIRPORT**  
DILLINGHAM, ALASKA  
AIRPORT LAYOUT PLAN  
EXISTING OFA AND OFZ  
PENETRATIONS

DATE:  
2/17/2023  
SHEET:  
5  
OF  
21





Designed By: MW/RLC  
 Drawn By: MW/RLC  
 Checked By: CJB  
 Date Plotted: 2/17/2023, 12:34 PM  
 Output Name: 14111  
 File Name: Z:\projects\2020\_01 DOI C.D.G. AMP\project\Civil\ACAD\ALP-DUG-Ultimate Layout.dwg

- NOTES:**
1. (X) TAXIWAY IDENTIFIER, SEE AIRPORT DATA SHEET.
  2. SEE SHEET 8 FOR ULTIMATE OFA AND OFZ PENETRATIONS.
  3. SEE ULTIMATE TERMINAL PLAN SHEET 11 FOR BUILDING DATA TABLE.
  4. CEMETERY TO RUNWAY CENTERLINE SEPARATION DISTANCE IS 315'.

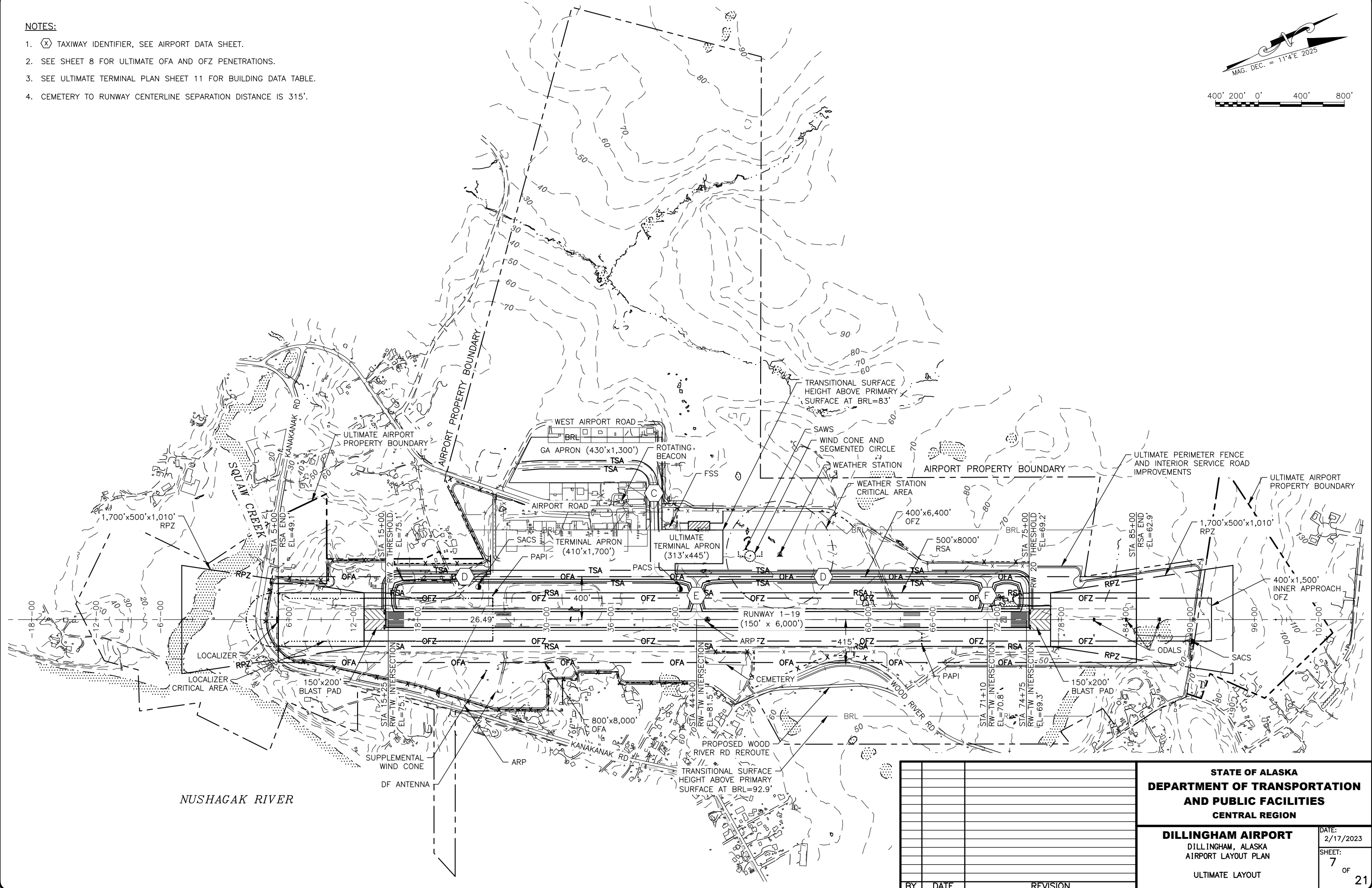
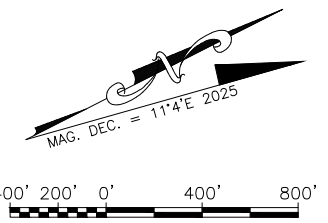

NUSHAGAK RIVER

BY	DATE	REVISION

**STATE OF ALASKA**  
**DEPARTMENT OF TRANSPORTATION**  
**AND PUBLIC FACILITIES**  
**CENTRAL REGION**

**DILLINGHAM AIRPORT**  
 DILLINGHAM, ALASKA  
 AIRPORT LAYOUT PLAN



ULTIMATE LAYOUT

DATE: 2/17/2023  
 SHEET: 7 OF 21

**NOTE:**

- 1. (X) TAXIWAY IDENTIFIER, SEE AIRPORT DATA SHEET.

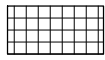
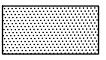
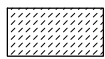
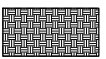
**LEGEND**

	OFA TREE PENETRATIONS		OFZ TREE PENETRATIONS
	OFA TERRAIN PENETRATIONS		OFZ TERRAIN PENETRATIONS
	OFA BUILDING PENETRATIONS		

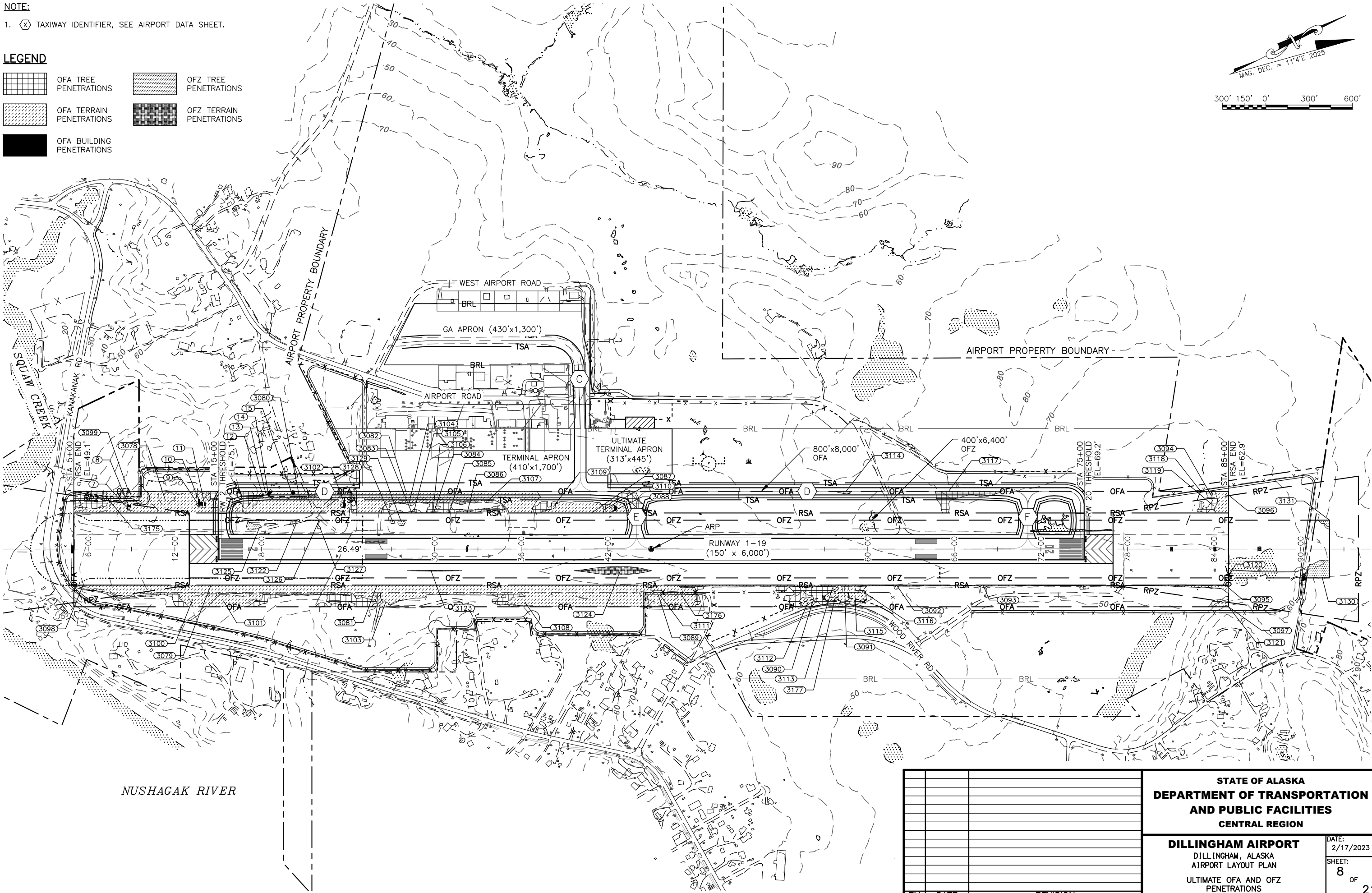
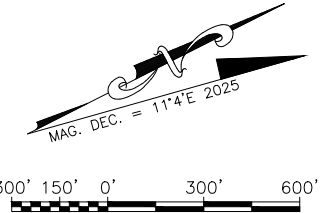

Designed By: MW/RLC  
 Drawn By: MW/RLC  
 Checked By: CJB  
 Date Plotted: 2/17/2023, 12:34 PM  
 Plot Number: 14112  
 File Name: Z:\pfs\pct\2020\_01\DOI\_C.B.G.AMP\pact\Civil\ACAD\VALP-DUG-Ultimate Layout.dwg

BY	DATE	REVISION

**STATE OF ALASKA**  
**DEPARTMENT OF TRANSPORTATION**  
**AND PUBLIC FACILITIES**  
**CENTRAL REGION**

---

**DILLINGHAM AIRPORT**  
 DILLINGHAM, ALASKA  
 AIRPORT LAYOUT PLAN  
 ULTIMATE OFA AND OFZ PENETRATIONS

DATE: 2/17/2023	SHEET: 8 OF 21
--------------------	-------------------



Designed By: MVA/RLC  
 Drawn By: MVA/RLC  
 Checked By: CLB  
 Date Plotted: 2/17/2023, 12:35 PM  
 Plot Number: EFP  
 File Name: Z:\projects\2020\_01\_DOT\_C\_BLG AMP\pilot\CA\Civil\ACAD\ALP-ALP-DUG-Existing Terminal Layout.dwg

BUILDING DATA TABLE						
ID#	DESCRIPTION	STATION	OFFSET	TOP ELEV. (MSL)	DISPOSITION	OBSTRUCTION MARKING
1	ALASKA AIR PRIDE, LLC	27+34.00	1028' LT	89.5'	REMAIN	N
2	FRESH WATER ADVENTURES	29+20.06	1022' LT	90.4'	REMAIN	N
3	ALASKA AIRLINES	30+43.87	1025' LT	89.9'	REMAIN	N
4	BAY AIR, INC.	31+86.77	1017' LT	87.9'	REMAIN	N
5	STARFLITE, INC.	33+30.53	1023' LT	87.1'	REMAIN	N
6	GRANT AVIATION, INC.	35+02.99	1021' LT	86.3'	REMAIN	N
7	AIRCRAFT CONSULTANTS & SERVICES, INC.	37+00.46	1029' LT	86.0'	REMAIN	N
8	FAA - FLIGHT SERVICE STATION	41+46.66	1012' LT	85.0'	REMAIN	N
9	ALASKA AIR ISLAND, INC.	30+78.64	1312' LT	91.2'	REMAIN	N
10	BRISTOL BAY AIR SERVICE, INC.	32+40.25	1364' LT	93.1'	REMAIN	N
11	US FISH AND WILDLIFE SERVICES	33+17.43	1346' LT	93.4'	REMAIN	N
12	TUCKER AVIATION, INC.	34+50.84	1326' LT	93.6'	REMAIN	N
13	SAND STORAGE	37+08.95	1405' LT	92.1'	REMAIN	N
14	MAINTENANCE GARAGE	38+32.53	1400' LT	90.2'	REMAIN	N
15	CONCRETE FOUNDATION SHOP	37+04.05	1347' LT	103.0'	REMAIN	N
16	CITY OF DILLINGHAM BUILDING	36+89.17	1294' LT	90.3'	REMAIN	N
17	ARFF/SREB	38+36.16	1247' LT	89.9'	REMAIN	N
18	BUILDING	31+22.30	1869' LT	89.7'	REMAIN	N
19	ADVENTIST WORLD AVIATION	33+60.49	1900' LT	91.4'	REMAIN	N
20	SHANNON'S AIR TAXI	35+02.18	1895' LT	91.3'	REMAIN	N
21	VAN AIR	36+42.44	1878' LT	91.0'	REMAIN	N
22	MULCHATNA AIR, LLC	39+65.32	1909' LT	86.9'	REMAIN	N

\*NO BUILDING HEIGHT INFORMATION OBTAINED FROM A SURVEY, TOP ELEVATION ESTIMATED AS GROUND PLUS 15 FEET.

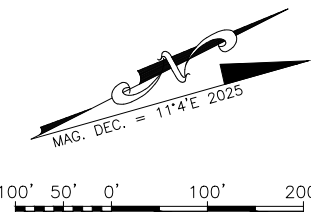
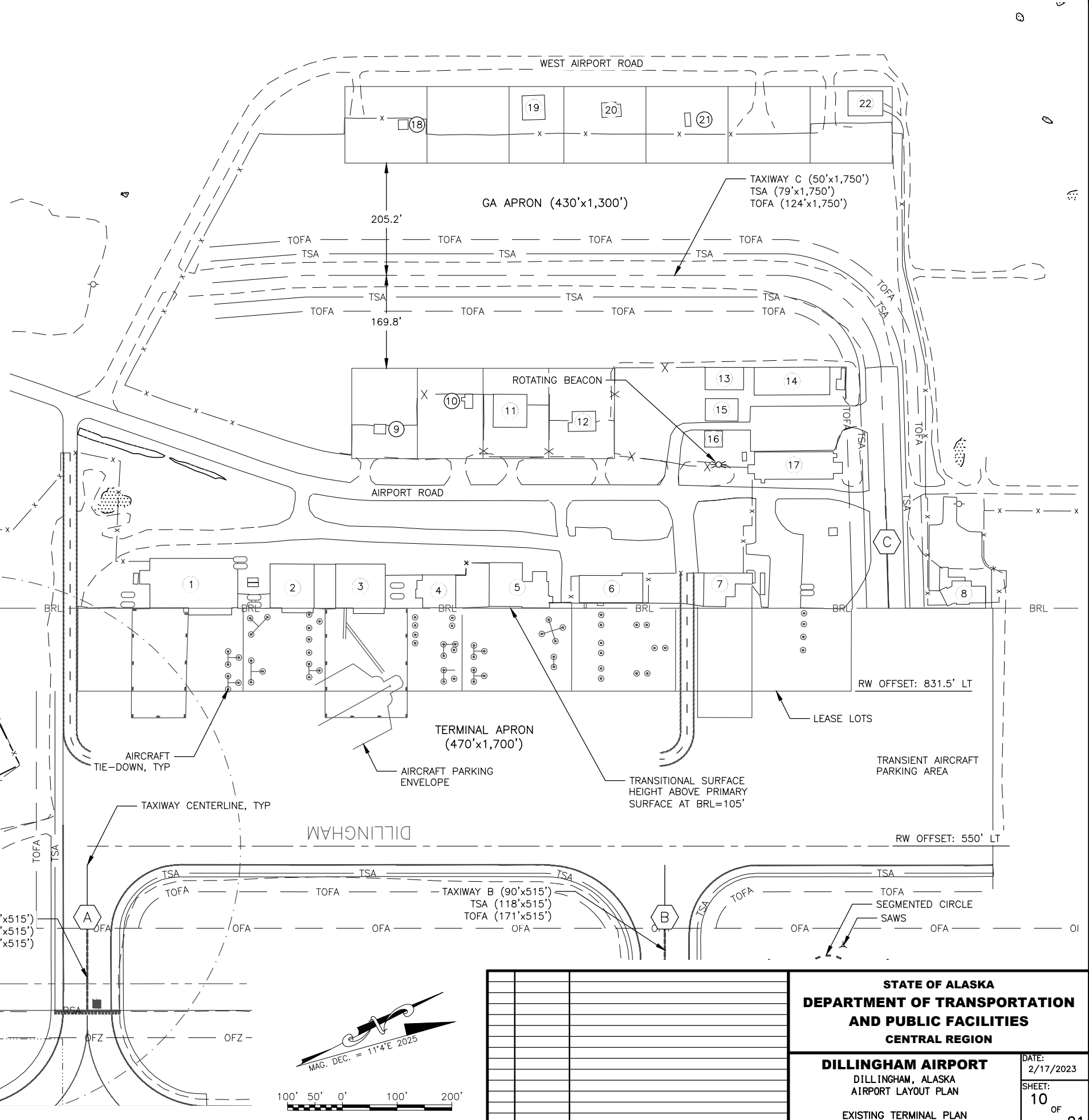

BY	DATE	REVISION

**STATE OF ALASKA**  
**DEPARTMENT OF TRANSPORTATION**  
**AND PUBLIC FACILITIES**  
**CENTRAL REGION**

---

**DILLINGHAM AIRPORT**  
 DILLINGHAM, ALASKA  
 AIRPORT LAYOUT PLAN

---

EXISTING TERMINAL PLAN

DATE:  
2/17/2023

SHEET:  
10  
OF  
21

**BUILDING DATA TABLE**

ID#	DESCRIPTION	STATION	OFFSET	TOP ELEV. (MSL)	DISPOSITION	OBSTRUCTION MARKING
1	ALASKA AIR PRIDE, LLC	27+34.00	1028' LT	89.5'	REMAIN	N
2	FRESH WATER ADVENTURES	29+20.06	1022' LT	90.4'	REMAIN	N
3	ALASKA AIRLINES	30+43.87	1025' LT	89.9'	REMAIN	N
4	BAY AIR, INC.	31+86.77	1017' LT	87.9'	REMAIN	N
5	STARFLITE, INC.	33+30.53	1023' LT	87.1'	REMAIN	N
6	GRANT AVIATION, INC.	35+02.99	1021' LT	86.3'	REMAIN	N
7	AIRCRAFT CONSULTANTS & SERVICES, INC.	37+00.46	1029' LT	86.0'	REMAIN	N
8	FAA - FLIGHT SERVICE STATION	41+46.66	1012' LT	85.0'	REMAIN	N
9	ALASKA AIR ISLAND, INC.	30+78.64	1312' LT	91.2'	REMAIN	N
10	BRISTOL BAY AIR SERVICE, INC.	32+40.25	1364' LT	93.1'	REMAIN	N
11	US FISH AND WILDLIFE SERVICES	33+17.43	1346' LT	93.4'	REMAIN	N
12	TUCKER AVIATION, INC.	34+50.84	1326' LT	93.6'	REMAIN	N
13	SAND STORAGE	37+08.95	1405' LT	92.1'	REMAIN	N
14	MAINTENANCE GARAGE	38+32.53	1400' LT	90.2'	REMAIN	N
15	CONCRETE FOUNDATION SHOP	37+04.05	1347' LT	103.0'	REMAIN	N
16	CITY OF DILLINGHAM BUILDING	36+89.17	1294' LT	90.3'	REMAIN	N
17	ARFF/SREB	38+36.16	1247' LT	89.9'	REMAIN	N
18	BUILDING	31+22.30	1869' LT	89.7'	REMAIN	N
19	ADVENTIST WORLD AVIATION	33+60.49	1900' LT	91.4'	REMAIN	N
20	SHANNON'S AIR TAXI	35+02.18	1895' LT	91.3'	REMAIN	N
21	VAN AIR	36+42.44	1878' LT	91.0'	REMAIN	N
22	MULCHATNA AIR, LLC	39+65.32	1909' LT	86.9'	REMAIN	N
23	SHARED OPERATION BUILDING	44+22.35	875' LT	84.3'	ULTIMATE	N

\*NO BUILDING HEIGHT INFORMATION OBTAINED FROM A SURVEY, TOP ELEVATION ESTIMATED AS GROUND PLUS 15 FEET.

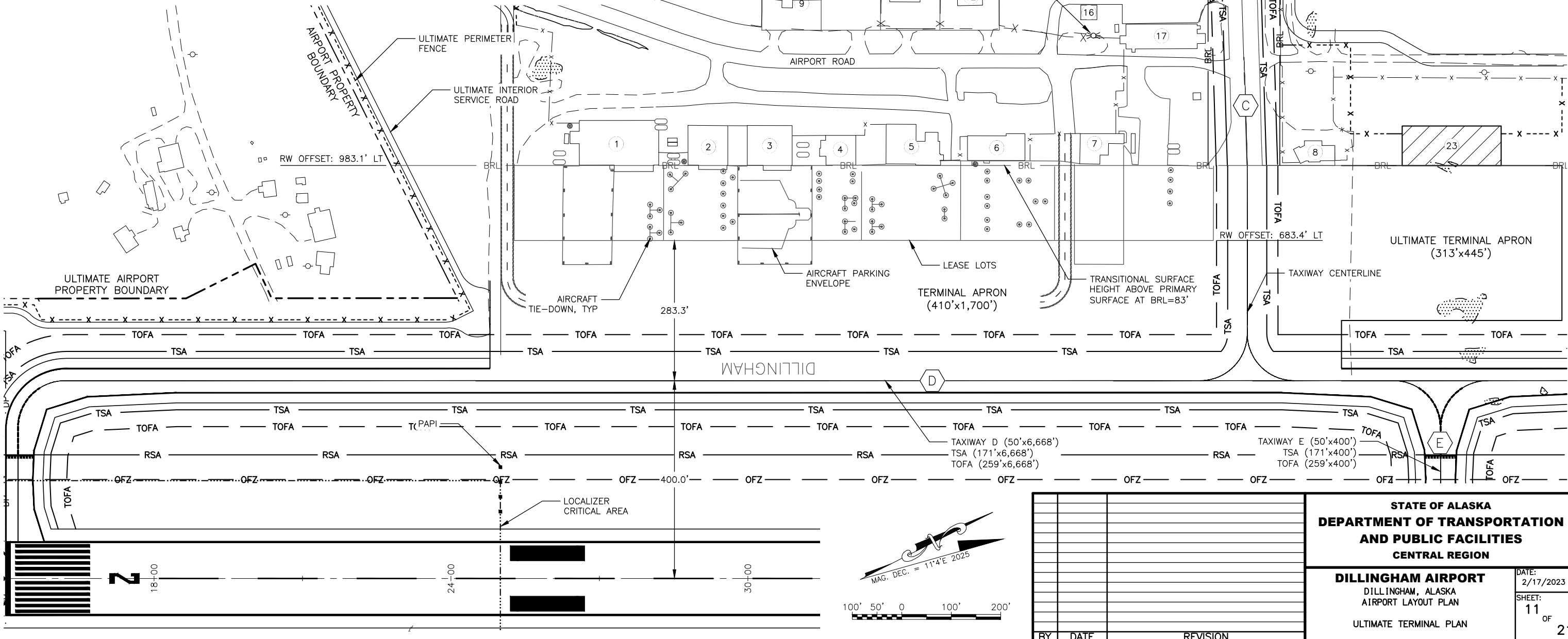

**STATE OF ALASKA  
DEPARTMENT OF TRANSPORTATION  
AND PUBLIC FACILITIES  
CENTRAL REGION**

**DILLINGHAM AIRPORT**  
DILLINGHAM, ALASKA  
AIRPORT LAYOUT PLAN

ULTIMATE TERMINAL PLAN

DATE: 2/17/2023	SHEET: 11 OF 21
-----------------	-----------------

Designed By: AW/RLC  
 Drawn By: AW/RLC  
 Checked By: CUB  
 Date Plotted: 2/17/2023, 12:35 PM  
 Plot Number: 11P  
 File Name: Z:\projects\2620\_01 DOI\_C.B.G.AMP\psect\Civil\ACAD\ALP-DUG-ultimate terminal layout.dwg

Designed By: MW/RLC  
 Drawn By: MW/RLC  
 Checked By: CLB  
 Date Plotted: 2/17/2023, 12:35 PM  
 Plot Number: RW 1-19  
 File Name: Z:\proj\sect\2020\_01\DOI\_C\_BLS AMP\post\Civil\ACAD\VALP-DLG-Ext\Intg Inner Approach.dwg

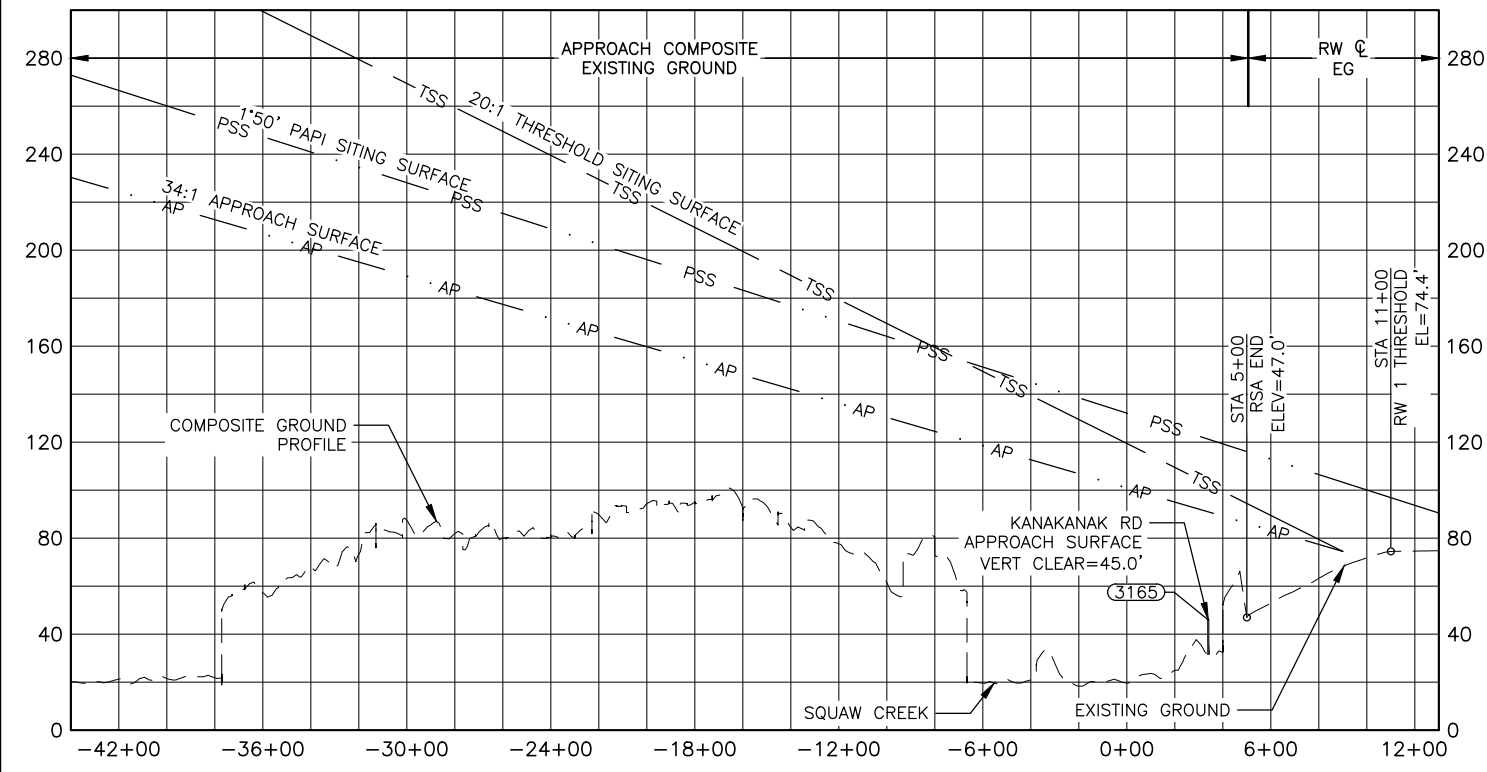
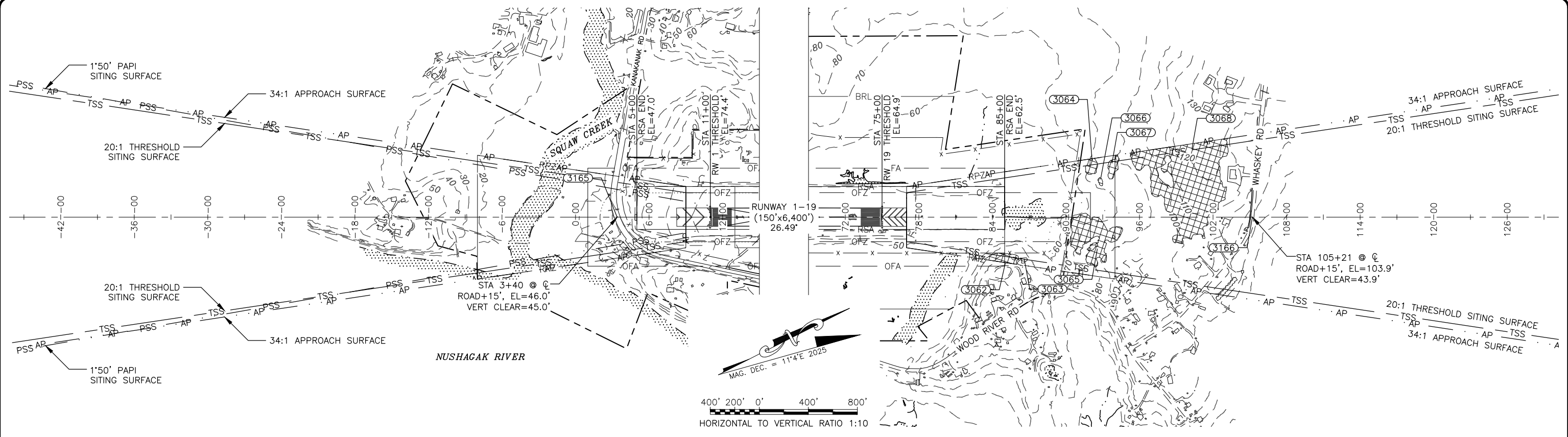

**EXISTING RUNWAY 1 INNER APPROACH**

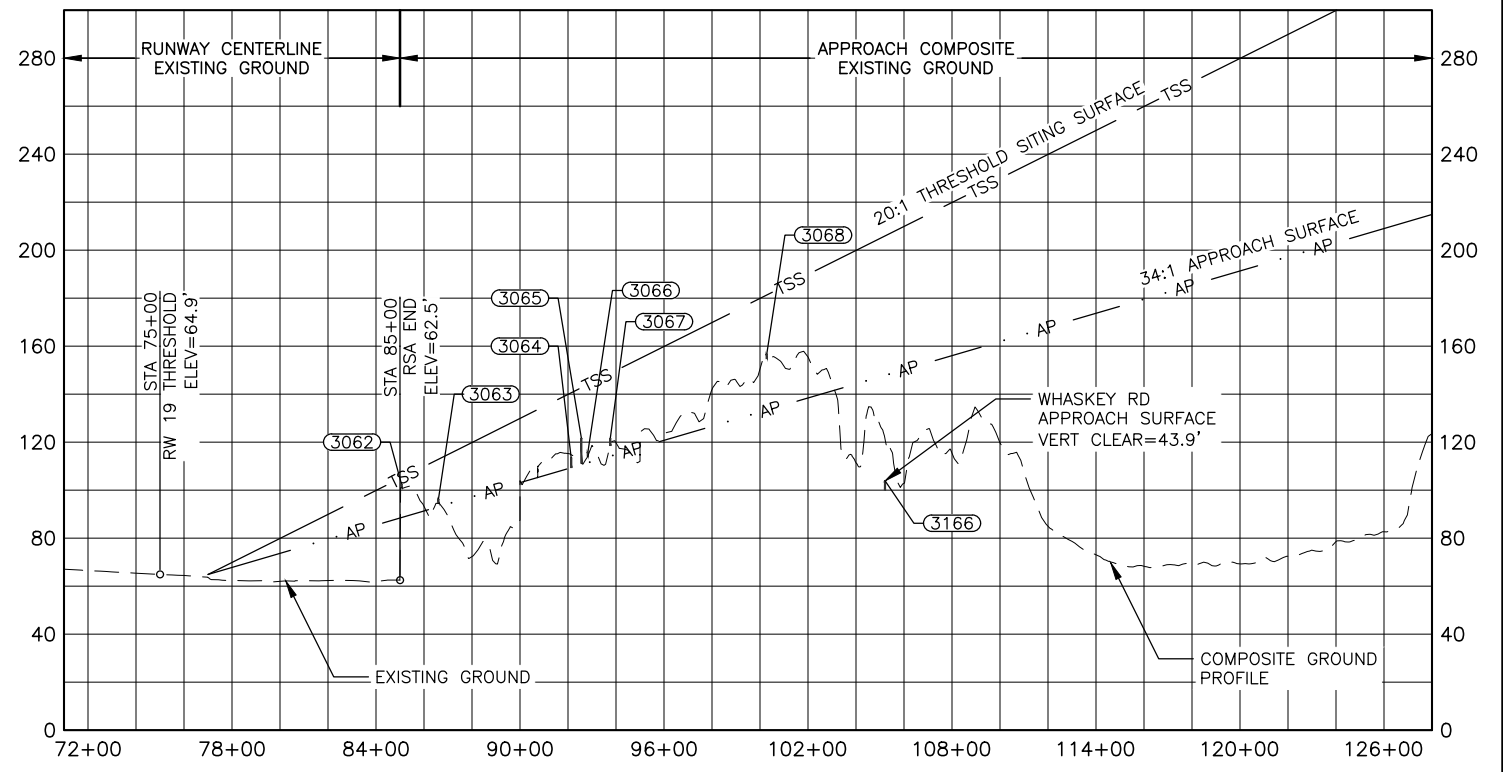

**EXISTING RUNWAY 19 INNER APPROACH**

**NOTES:**

- THRESHOLD SITING CRITERIA FOR RW 1 AND RW 19 IS DEFINED PER FAA AC 150/5300-13B TABLE 3-3 FOR APPROACH ENDS OF RUNWAYS THAT SUPPORT IFR CIRCLING PROCEDURES AND PROCEDURES ONLY PROVIDING LATERAL GUIDANCE AND VISIBILITY MINIMUMS  $\geq 3/4$  STATUTE MILE.
- THERE ARE NO CONTROLLING OBSTRUCTIONS FOR THE APPROACH TO RUNWAY 1. THE OBSTRUCTION CLEARANCE SLOPE IS ESTABLISHED AS 34:1 PER AIRPORT GIS DATA INFORMATION PORTAL (ADIP), AIRPORT MASTER RECORDS DATA DICTIONARY, DATA ELEMENT 57.
- THE CONTROLLING OBSTRUCTION FOR THE APPROACH TO RUNWAY 19 ARE TREES. THE OBSTRUCTION CLEARANCE SLOPE IS ESTABLISHED AS 21:1 PER AIRPORT GIS DATA INFORMATION PORTAL (ADIP), AIRPORT MASTER RECORDS DATA DICTIONARY, DATA ELEMENT 57.
- SEE AIRSPACE PART 77 SHEET FOR OBSTRUCTIONS TO PART 77 SURFACES.
- REFER TO SHEET 9 FOR OBSTRUCTION TABLE.

**LEGEND**

FAR PART 77 TREE PENETRATIONS

BY	DATE	REVISION

**STATE OF ALASKA**  
**DEPARTMENT OF TRANSPORTATION**  
**AND PUBLIC FACILITIES**  
**CENTRAL REGION**

**DILLINGHAM AIRPORT**  
 DILLINGHAM, ALASKA  
 AIRPORT LAYOUT PLAN  
 EXISTING INNER PORTION OF RW  
 1-19 APPROACH SURFACE

DATE: 2/17/2023  
 SHEET: 12 OF 21

Designed By: MM/RLC  
 Drawn By: MM/RLC  
 Checked By: CLB

Date Plotted: 2/17/2023, 12:35 PM  
 Plot Number: E01  
 File Name: Z:\projects\2020\_01 DOI\_C.B.G.AMP\posts\Civil\ACAD\ALP\ALP-DUG-Existing Inner Approach.dwg

EXISTING TSS OBSTRUCTIONS (RW 1)								
ID#	DESCRIPTION	STATION/ OFFSET	ELEVATION	SURFACE PENETRATED	SURFACE ELEVATION	AMOUNT PENETRATED	DISPOSITION	STAGE TO CORRECT
3165	ROAD+15'	3+40 / $\varnothing$	46.0'	NONE	91.0'	NONE	REMAIN	N/A
EXISTING INNER APPROACH OBSTRUCTIONS (RW 1)								
ID#	DESCRIPTION	STATION/ OFFSET	ELEVATION	SURFACE PENETRATED	SURFACE ELEVATION	AMOUNT PENETRATED	DISPOSITION	STAGE TO CORRECT
3165	ROAD+15'	3+40 / $\varnothing$	46.0'	NONE	102.5'	NONE	REMAIN	N/A

EXISTING TSS OBSTRUCTIONS (RW 19)								
ID#	DESCRIPTION	STATION/ OFFSET	ELEVATION	SURFACE PENETRATED	SURFACE ELEVATION	AMOUNT PENETRATED	DISPOSITION	STAGE TO CORRECT
3166	ROAD+15'	105+21 / $\varnothing$	103.9'	NONE	147.8'	NONE	REMAIN	N/A
EXISTING INNER APPROACH OBSTRUCTIONS (RW 19)								
ID#	DESCRIPTION	STATION/ OFFSET	ELEVATION	SURFACE PENETRATED	SURFACE ELEVATION	AMOUNT PENETRATED	DISPOSITION	STAGE TO CORRECT
3062	TREES (HP)	85+06 / 371.0' RT	102.3'	APPROACH	88.6'	13.7'	REMOVE	ULTIMATE
3063	TREES (HP)	86+60 / 341.5' RT	96.1'	APPROACH	93.1'	3.0'	REMOVE	ULTIMATE
3064	TREES (HP)	92+13 / 460.3' LT	113.4'	APPROACH	109.4'	4.0'	REMOVE	ULTIMATE
3065	TREES (HP)	92+55 / 259.1' RT	121.5'	APPROACH	110.6'	10.9'	REMOVE	ULTIMATE
3066	TREES (HP)	92+82 / 310.0' LT	115.8'	APPROACH	111.4'	4.4'	REMOVE	ULTIMATE
3067	TREES (HP)	93+76 / 441.3' LT	121.5'	APPROACH	114.2'	7.3'	REMOVE	ULTIMATE
3068	TREES (HP)	100+28 / 556.8' LT	156.6'	APPROACH	133.3'	23.3'	REMOVE	ULTIMATE
3166	ROAD+15'	105+21 / $\varnothing$	103.9'	NONE	205.9'	NONE	REMAIN	N/A

**OBSTRUCTION NOTE:**

- 1. (HP) = POINT OF HIGHEST PENETRATION.

		<b>STATE OF ALASKA</b> <b>DEPARTMENT OF TRANSPORTATION</b> <b>AND PUBLIC FACILITIES</b> <b>CENTRAL REGION</b>	
		<b>DILLINGHAM AIRPORT</b> DILLINGHAM, ALASKA AIRPORT LAYOUT PLAN EXISTING INNER PORTION OF APPROACH SURFACE OBSTRUCTION TABLES	
		DATE:	2/17/2023
		SHEET:	13
		OF	21
BY	DATE	REVISION	



Designed By: MW/RLC  
 Drawn By: MW/RLC  
 Checked By: CLB  
 Date Plotted: 2/17/2023, 12:36 PM  
 Plot Number: RW 2-20  
 File Name: Z:\projects\2020\_01 DOI\_C.B.G.AMP\project\Civil\ACAD\ALP-DUG-Ultimate\_Inner\_Approach.dwg

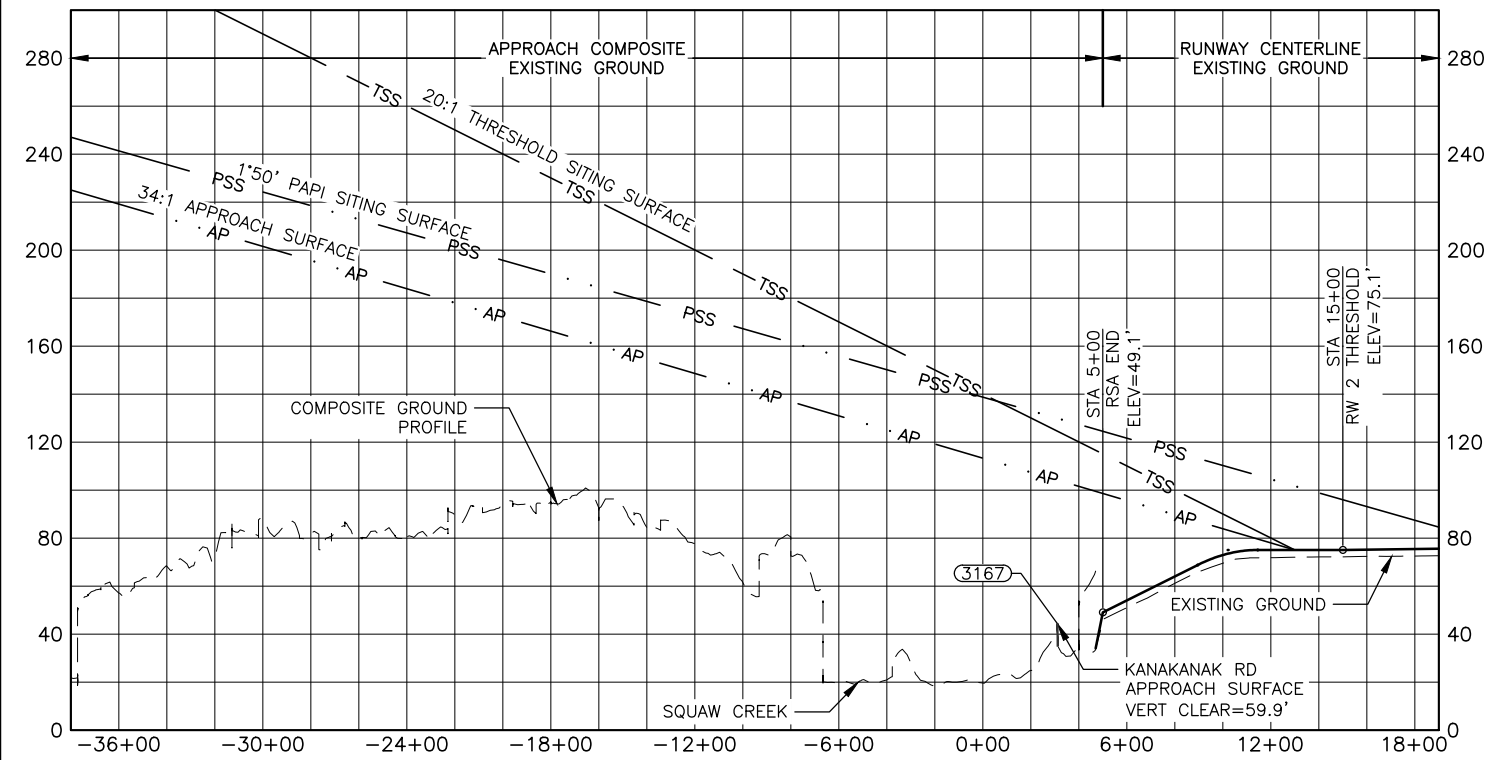
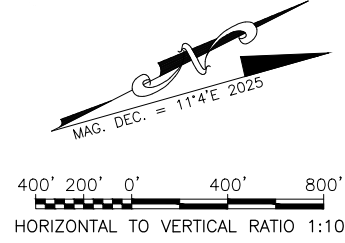
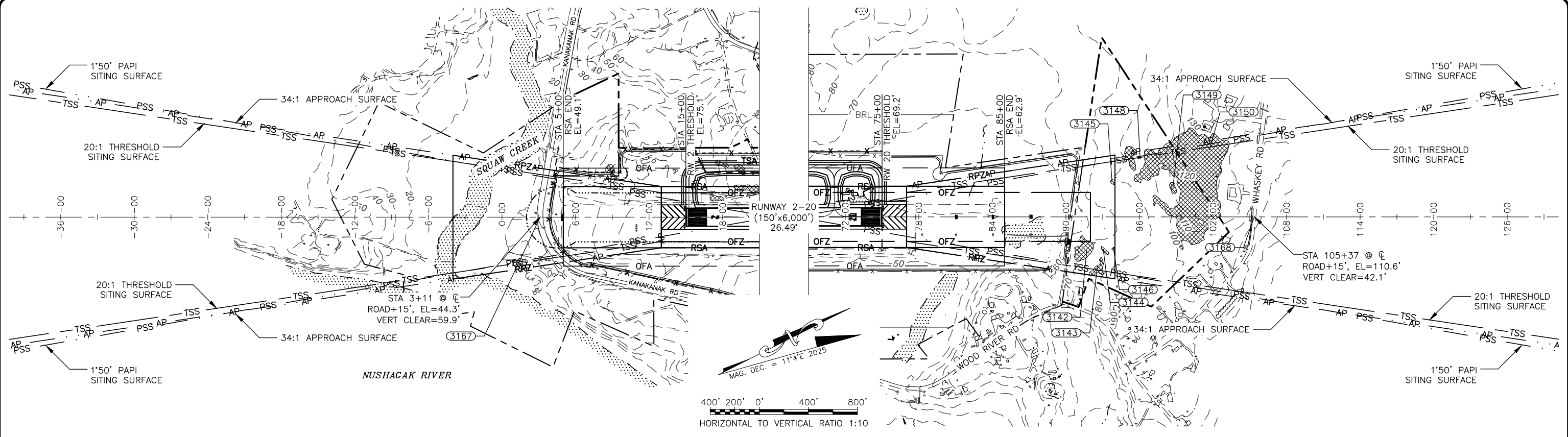

**ULTIMATE RUNWAY 2 INNER APPROACH**

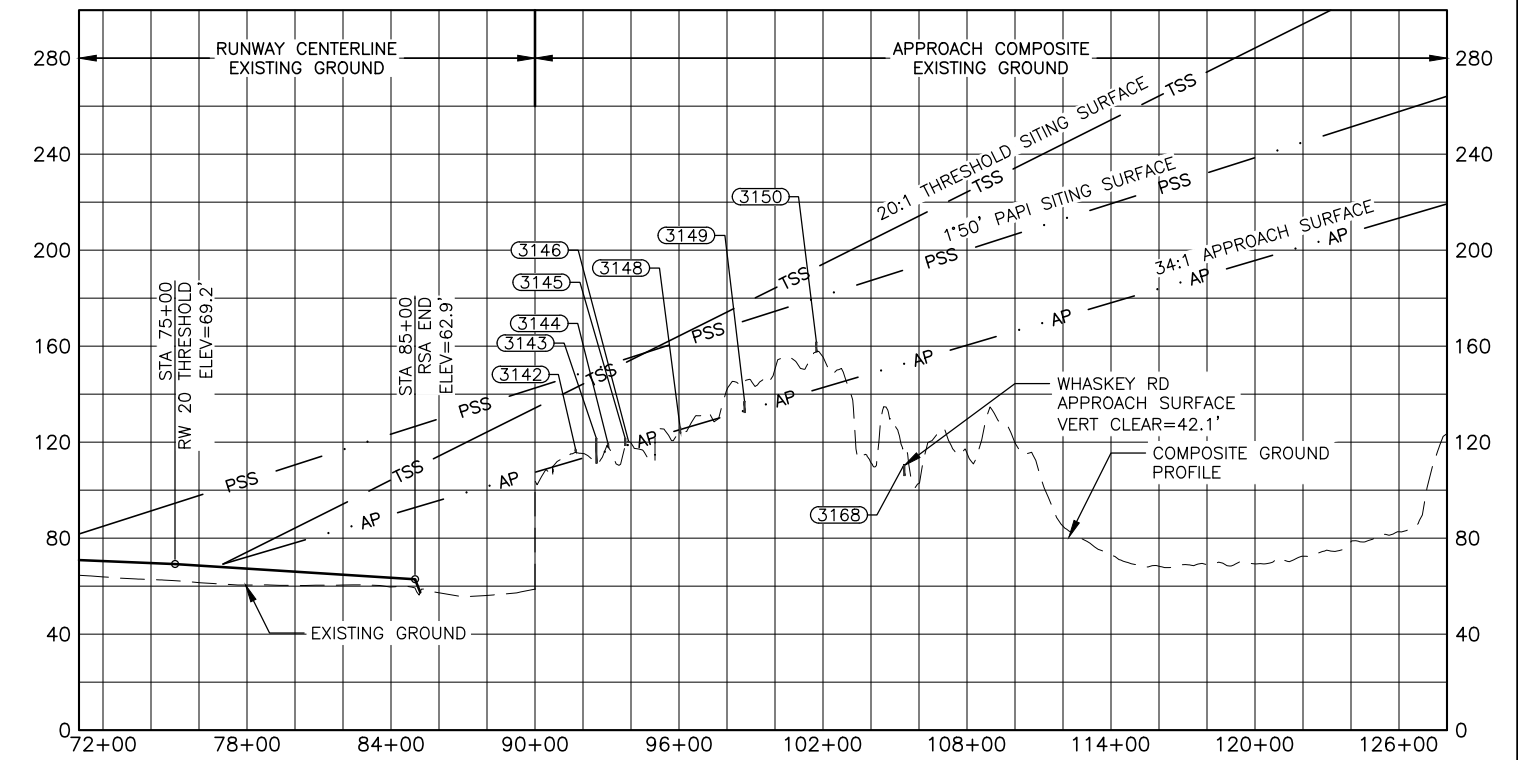

**ULTIMATE RUNWAY 20 INNER APPROACH**

**NOTES:**

- THRESHOLD SITING CRITERIA FOR RW 2 AND RW 20 IS DEFINED PER FAA AC 150/5300-13B TABLE 3-3 FOR APPROACH ENDS OF RUNWAYS THAT SUPPORT IFR CIRCLING PROCEDURES AND PROCEDURES ONLY PROVIDING LATERAL GUIDANCE AND VISIBILITY MINIMUMS  $\geq 3/4$  STATUTE MILE.
- THERE ARE NO CONTROLLING OBSTRUCTIONS FOR THE APPROACH TO RUNWAY 2. THE OBSTRUCTION CLEARANCE SLOPE IS ESTABLISHED AS 34:1 PER AIRPORT GIS DATA INFORMATION PORTAL (ADIP), AIRPORT MASTER RECORDS DATA DICTIONARY, DATA ELEMENT 57.
- THE CONTROLLING OBSTRUCTION FOR THE APPROACH TO RUNWAY 20 ARE TREES. THE OBSTRUCTION CLEARANCE SLOPE IS ESTABLISHED AS 26:1 PER AIRPORT GIS DATA INFORMATION PORTAL (ADIP), AIRPORT MASTER RECORDS DATA DICTIONARY, DATA ELEMENT 57.
- SEE AIRSPACE PART 77 SHEET FOR OBSTRUCTIONS TO PART 77 SURFACES.
- REFER TO SHEET 11 FOR OBSTRUCTION TABLE.

**LEGEND**

FAR PART 77 TREE PENETRATIONS

BY	DATE	REVISION

**STATE OF ALASKA**  
**DEPARTMENT OF TRANSPORTATION**  
**AND PUBLIC FACILITIES**  
**CENTRAL REGION**

**DILLINGHAM AIRPORT**  
 DILLINGHAM, ALASKA  
 AIRPORT LAYOUT PLAN  
 ULTIMATE INNER PORTION OF RW  
 2-20 APPROACH SURFACE

DATE: 2/17/2023  
 SHEET: 14 OF 21

Designed By: MM/RLC  
 Drawn By: MM/RLC  
 Checked By: CLB

Date Plotted: 2/17/2023, 12:36 PM  
 Plot Number: 107  
 File Name: Z:\project\2020\_01 DOI\_C.B.G.AMP\posts\Civil\ACAD\ALP-DUG-ultimate Inner Approach.dwg

ULTIMATE TSS OBSTRUCTIONS (RW 2)								
ID#	DESCRIPTION	STATION/ OFFSET	ELEVATION	SURFACE PENETRATED	SURFACE ELEVATION	AMOUNT PENETRATED	DISPOSITION	STAGE TO CORRECT
3167	ROAD+15'	3+11 / $\varnothing$	44.3'	NONE	104.2'	NONE	REMAIN	N/A
ULTIMATE INNER APPROACH OBSTRUCTIONS (RW 2)								
ID#	DESCRIPTION	STATION/ OFFSET	ELEVATION	SURFACE PENETRATED	SURFACE ELEVATION	AMOUNT PENETRATED	DISPOSITION	STAGE TO CORRECT
3167	ROAD+15'	3+11 / $\varnothing$	44.3'	NONE	124.5'	NONE	REMAIN	N/A

ULTIMATE TSS OBSTRUCTIONS (RW 20)								
ID#	DESCRIPTION	STATION/ OFFSET	ELEVATION	SURFACE PENETRATED	SURFACE ELEVATION	AMOUNT PENETRATED	DISPOSITION	STAGE TO CORRECT
3168	ROAD+15'	105+37 / $\varnothing$	110.6'	NONE	152.7'	NONE	REMAIN	N/A
ULTIMATE INNER APPROACH OBSTRUCTIONS (RW 20)								
ID#	DESCRIPTION	STATION/ OFFSET	ELEVATION	SURFACE PENETRATED	SURFACE ELEVATION	AMOUNT PENETRATED	DISPOSITION	STAGE TO CORRECT
3142	TREE (HP)	91+69 / 276.5' RT	116.7'	APPROACH	112.5'	4.2'	REMOVE	ULTIMATE
3143	TREE (HP)	92+55 / 409.1' RT	121.5'	APPROACH	115.0'	6.5'	REMOVE	ULTIMATE
3144	TREE (HP)	93+04 / 266.1' RT	119.2'	APPROACH	116.4'	2.8'	REMOVE	ULTIMATE
3145	TREE (HP)	93+76 / 291.3' LT	121.5'	APPROACH	118.5'	3.0'	REMOVE	ULTIMATE
3146	TREE (HP)	93+89 / 259.4' RT	120.3'	APPROACH	118.9'	1.4'	REMOVE	ULTIMATE
3148	TREE (HP)	96+04 / 483.1' LT	126.1'	APPROACH	125.2'	0.9'	REMOVE	ULTIMATE
3149	TREE (HP)	98+73 / 235.5' LT	136.9'	APPROACH	133.1'	3.8'	REMOVE	ULTIMATE
3150	TREE (HP)	101+72 / 548.7' LT	161.6'	APPROACH	141.9'	19.7'	REMOVE	ULTIMATE
3168	ROAD+15'	105+37 / $\varnothing$	110.6'	NONE	211.1'	NONE	REMAIN	N/A

**OBSTRUCTION NOTE:**

- (HP) = POINT OF HIGHEST PENETRATION.

		<b>STATE OF ALASKA DEPARTMENT OF TRANSPORTATION AND PUBLIC FACILITIES CENTRAL REGION</b>	
		<b>DILLINGHAM AIRPORT</b> DILLINGHAM, ALASKA AIRPORT LAYOUT PLAN ULTIMATE INNER PORTION OF APPROACH SURFACE OBSTRUCTION TABLES	
		DATE: 2/17/2023	
		SHEET: 15	OF 21
BY	DATE	REVISION	

Designed By: AW/RLC  
 Drawn By: AW/RLC  
 Checked By: CLB

Date Plotted: 2/17/2023, 12:39 PM  
 Plot Name: RW 1-19  
 File Name: Z:\projects\2020\_01 DOI\_C.B.G.A.M.P.\p020\_01 DOI\_C.B.G.A.M.P.\ALP\ALP-DLG-Existing Departure.dwg

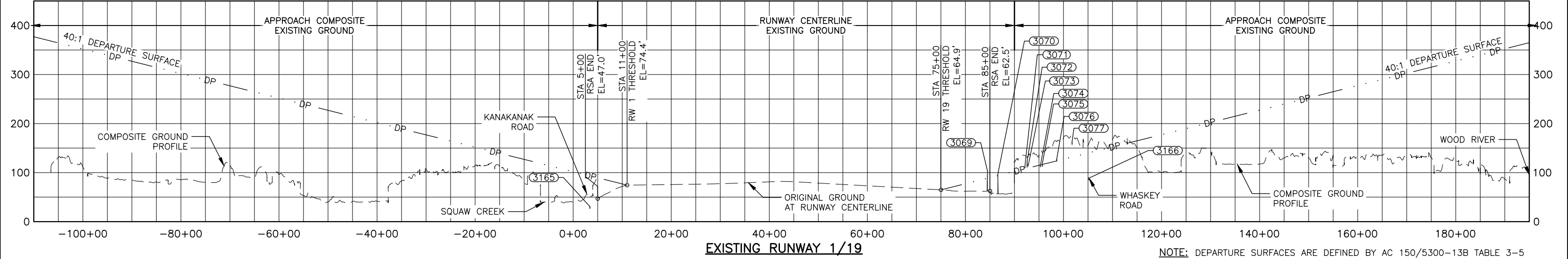
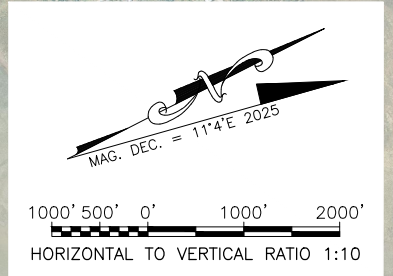
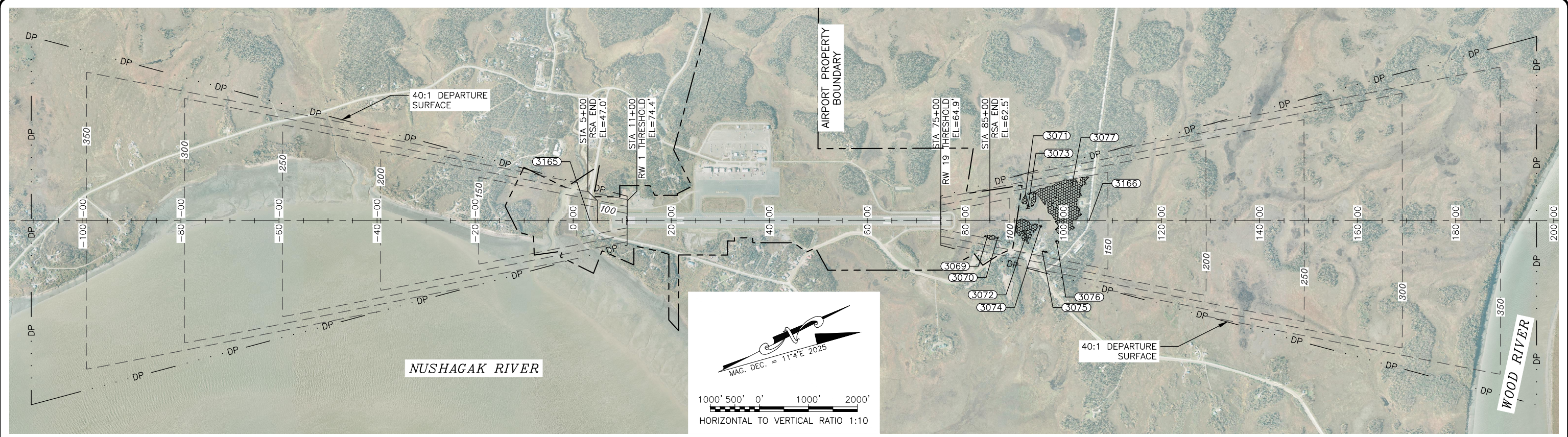

NOTE: DEPARTURE SURFACES ARE DEFINED BY AC 150/5300-13B TABLE 3-5 AND RUNWAY WIDTH OF 150'.

RW 1 DEPARTURE SURFACE OBSTRUCTION & SIGNIFICANT OBJECT TABLE								
ID#	DESCRIPTION	STATION/OFFSET	ELEVATION	SURFACE PENETRATED	SURFACE ELEVATION	AMOUNT PENETRATED	DISPOSITION	STAGE TO CORRECT
3165	ROAD+15'	3+40 / $\varnothing$	46.0'	NONE	93.5'	NONE	REMAIN	N/A

OBSTRUCTION NOTE:  
 1. (HP) = POINT OF HIGHEST PENETRATION

**LEGEND**  
 DEPARTURE SURFACE TREE PENETRATIONS

RW 19 DEPARTURE SURFACE OBSTRUCTION & SIGNIFICANT OBJECT TABLE								
ID#	DESCRIPTION	STATION/OFFSET	ELEVATION	SURFACE PENETRATED	SURFACE ELEVATION	AMOUNT PENETRATED	DISPOSITION	STAGE TO CORRECT
3069	TREE (HP)	84+52 / 310.6' RT	101.9'	DEPARTURE	88.7'	13.2'	REMOVE	ULTIMATE
3070	TREE (HP)	86+60 / 341.5' RT	96.1'	DEPARTURE	93.9'	2.3'	REMOVE	ULTIMATE
3071	TREE (HP)	92+13 / 460.3' LT	113.4'	DEPARTURE	107.7'	5.7'	REMOVE	ULTIMATE
3072	TREE (HP)	92+55 / 259.1' RT	121.5'	DEPARTURE	108.8'	12.7'	REMOVE	ULTIMATE
3073	TREE (HP)	92+82 / 310.0' LT	115.8'	DEPARTURE	109.4'	6.3'	REMOVE	ULTIMATE
3074	TREE (HP)	95+31 / 116.1' RT	115.9'	DEPARTURE	115.7'	0.2'	REMOVE	ULTIMATE
3075	TREE (HP)	95+67 / 629.7' RT	118.0'	DEPARTURE	116.8'	1.2'	REMOVE	ULTIMATE
3076	TREE (HP)	98+60 / 419.2' RT	127.2'	DEPARTURE	123.9'	3.3'	REMOVE	ULTIMATE
3077	TREE (HP)	101+70 / 698.7' LT	161.6'	DEPARTURE	131.7'	29.9'	REMOVE	ULTIMATE
3166	ROAD+15'	105+21 / $\varnothing$	103.9'	NONE	140.4'	NONE	REMAIN	N/A

BY	DATE	REVISION

**STATE OF ALASKA**  
**DEPARTMENT OF TRANSPORTATION**  
**AND PUBLIC FACILITIES**  
**CENTRAL REGION**

**DILLINGHAM AIRPORT**  
 DILLINGHAM, ALASKA  
 AIRPORT LAYOUT PLAN  
 EXISTING RW 1-19 DEPARTURE SURFACE

DATE: 2/17/2023  
 SHEET: 16 OF 21

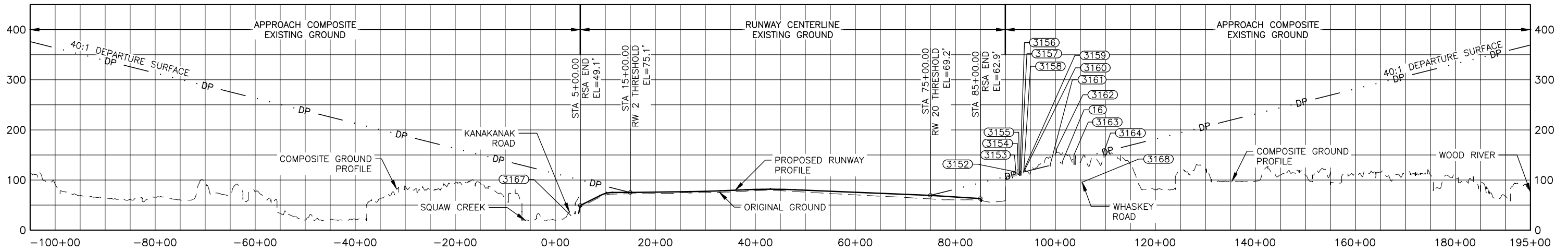
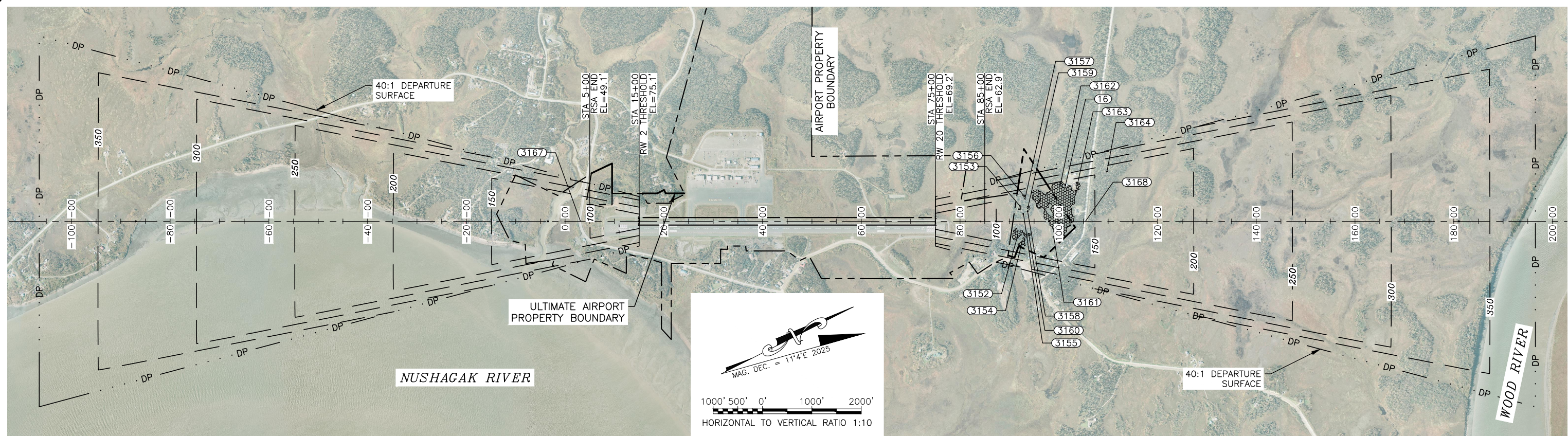

**ULTIMATE RUNWAY 2/20**

NOTE: DEPARTURE SURFACES ARE DEFINED BY AC 150/5300-13B TABLE 3-5 AND RUNWAY WIDTH OF 150'.

RW 2 DEPARTURE SURFACE OBSTRUCTION & SIGNIFICANT OBJECT TABLE								
ID#	DESCRIPTION	STATION/OFFSET	ELEVATION	SURFACE PENETRATED	SURFACE ELEVATION	AMOUNT PENETRATED	DISPOSITION	STAGE TO CORRECT
3167	ROAD+15'	3+11 / ☐	44.3'	NONE	104.9'	NONE	REMAIN	N/A

RW 20 DEPARTURE SURFACE OBSTRUCTION & SIGNIFICANT OBJECT TABLE								
ID#	DESCRIPTION	STATION/OFFSET	ELEVATION	SURFACE PENETRATED	SURFACE ELEVATION	AMOUNT PENETRATED	DISPOSITION	STAGE TO CORRECT
16	BUILDING	101+35 / 737.5' LT	135.6'	DEPARTURE	135.1'	0.5'	REMOVE	ULTIMATE
3152	TREE (HP)	91+72 / 267.1' RT	116.9'	DEPARTURE	111.1'	5.9'	REMOVE	ULTIMATE
3153	TREE (HP)	92+13 / 310.3' LT	113.4'	DEPARTURE	112.1'	1.3'	REMOVE	ULTIMATE
3154	TREE (HP)	92+55 / 409.1' RT	121.5'	DEPARTURE	113.1'	8.4'	REMOVE	ULTIMATE
3155	TREE (HP)	92+82 / 160.0' LT	115.8'	DEPARTURE	113.8'	2.0'	REMOVE	ULTIMATE
3156	TREE (HP)	92+93 / 517.5' LT	115.2'	DEPARTURE	114.1'	1.1'	REMOVE	ULTIMATE
3157	TREE (HP)	93+13 / 453.9' LT	114.8'	DEPARTURE	114.6'	0.2'	REMOVE	ULTIMATE
3158	TREE (HP)	93+67 / 206.3' LT	117.1'	DEPARTURE	115.9'	1.1'	REMOVE	ULTIMATE
3159	TREE (HP)	93+76 / 291.4' LT	121.5'	DEPARTURE	116.2'	5.3'	REMOVE	ULTIMATE
3160	TREE (HP)	93+89 / 259.4' RT	120.3'	DEPARTURE	116.5'	3.8'	REMOVE	ULTIMATE
3161	TREE (HP)	98+98 / 318.3' RT	131.0'	DEPARTURE	129.2'	1.8'	REMOVE	ULTIMATE
3162	TREE (HP)	100+24 / 704.3' LT	162.1'	DEPARTURE	132.4'	29.7'	REMOVE	ULTIMATE
3163	TREE (HP)	103+72 / 728.5' LT	150.3'	DEPARTURE	141.1'	9.3'	REMOVE	ULTIMATE

RW 20 DEPARTURE SURFACE OBSTRUCTION & SIGNIFICANT OBJECT TABLE								
ID#	DESCRIPTION	STATION/OFFSET	ELEVATION	SURFACE PENETRATED	SURFACE ELEVATION	AMOUNT PENETRATED	DISPOSITION	STAGE TO CORRECT
3164	TREE (HP)	109+73 / 1002.2' LT	156.8'	DEPARTURE	156.1'	0.7'	REMOVE	ULTIMATE
3168	ROAD+15'	105+37 / ☐	110.6'	NONE	145.2'	NONE	REMAIN	N/A

**OBSTRUCTION NOTE:**  
 1. (HP) = POINT OF HIGHEST PENETRATION

**LEGEND**  
 DEPARTURE SURFACE  
 TREE PENETRATIONS

BY	DATE	REVISION

**STATE OF ALASKA  
 DEPARTMENT OF TRANSPORTATION  
 AND PUBLIC FACILITIES  
 CENTRAL REGION**

**DILLINGHAM AIRPORT**  
 DILLINGHAM, ALASKA  
 AIRPORT LAYOUT PLAN  
 ULTIMATE RW 2-20 DEPARTURE SURFACE

DATE: 2/17/2023  
 SHEET: 17 OF 17

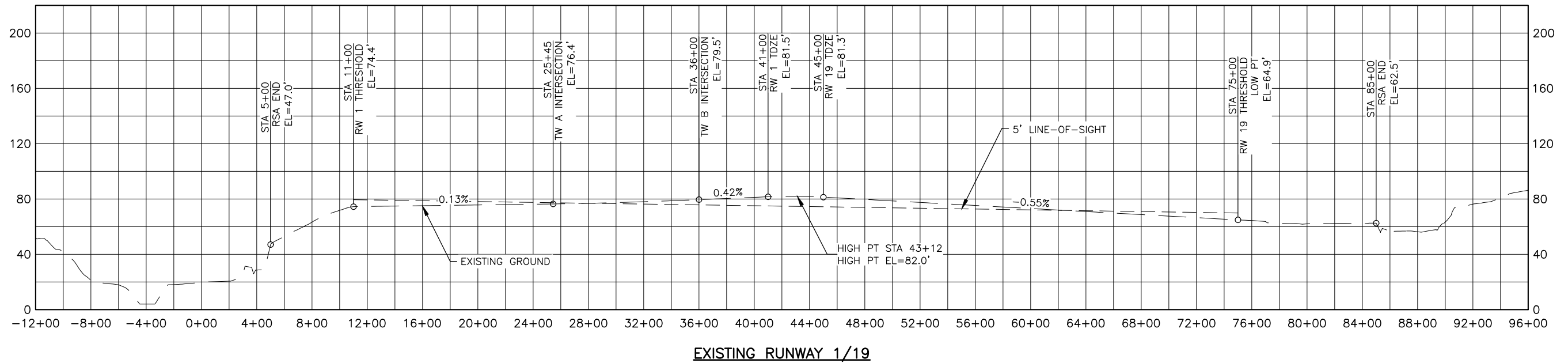

EXISTING RUNWAY 1/19

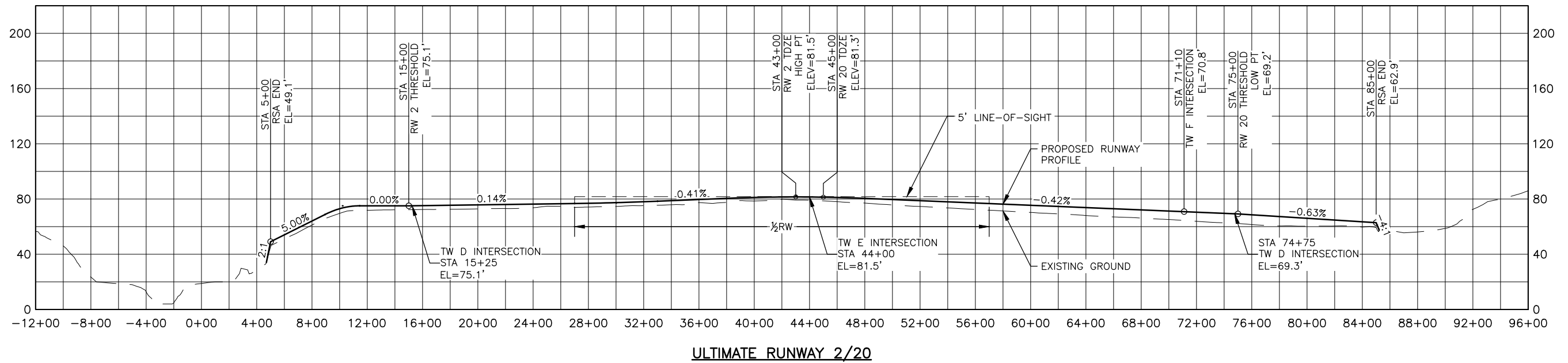

ULTIMATE RUNWAY 2/20

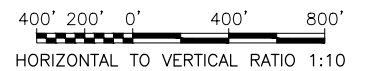

NOTES:

- EXISTING RUNWAY DOES NOT MEET LINE-OF-SIGHT CRITERIA.
- EXISTING RUNWAY GRADES ARE TAKEN FROM DILLINGHAM RUNWAY REHABILITATION (CFAPT00104) AS-BUILT.
- RUNWAY 5' LINE-OF-SIGHT DEPICTS MOST DEMANDING CONDITION IN ULTIMATE CONFIGURATION.

BY	DATE	REVISION

STATE OF ALASKA  
 DEPARTMENT OF TRANSPORTATION  
 AND PUBLIC FACILITIES  
 CENTRAL REGION

**DILLINGHAM AIRPORT**  
 DILLINGHAM, ALASKA  
 AIRPORT LAYOUT PLAN

RUNWAY PROFILES

DATE:  
 2/17/2023  
 SHEET:  
 18  
 OF  
 21

Drawn By: MWA/RLC  
 Checked By: MWA/RLC  
 Date: 2/17/2023

Date Plotted: 2/17/2023 12:41 PM  
 Plot Number: 01  
 File Name: Z:\projects\2020\_01 DOI\_C.B.G.AMP\project\Civil\ACAD\ALP-DUG-Airport-Airspace.dwg

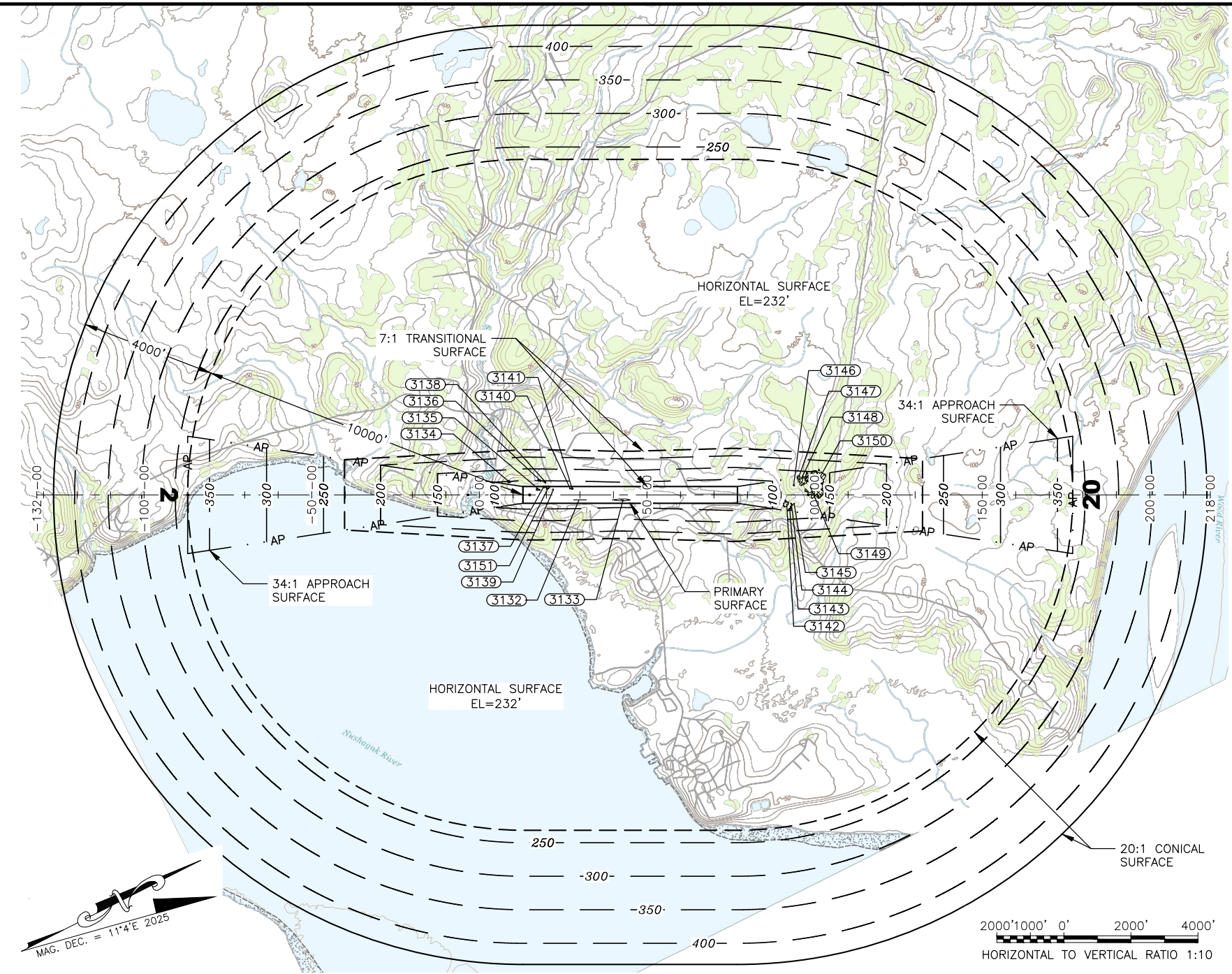

PART 77 AIRSPACE OBSTRUCTIONS TABLE								
ID#	DESCRIPTION	STATION/OFFSET	ELEVATION	SURFACE PENETRATED	SURFACE ELEVATION	AMOUNT PENETRATED	DISPOSITION	STAGE TO CORRECT
3132	TERRAIN	29+74 / 150.0' RT	77.4'	PRIMARY	77.3'	0.04'	REMOVE	ULTIMATE
3133	TERRAIN	42+86 / 150.0' RT	82.0'	PRIMARY	81.5'	0.5'	REMOVE	ULTIMATE
3134	TREE (HP)	8+78 / 400.0' LT	105.4'	TRANSITIONAL	99.9'	5.5'	REMOVE	ULTIMATE
3135	TREE (HP)	17+86 / 150.8' LT	77.2'	TRANSITIONAL	75.5'	1.8'	REMOVE	ULTIMATE
3136	TREE (HP)	18+11 / 431.7' LT	104.1'	TRANSITIONAL	101.5'	2.6'	REMOVE	ULTIMATE
3137	TREE (HP)	19+23 / 250.0' LT	77.3'	PRIMARY	75.7'	1.6'	REMOVE	ULTIMATE
3138	TREE (HP)	19+52 / 404.2' LT	101.7'	TRANSITIONAL	97.7'	3.9'	REMOVE	ULTIMATE
3139	TREE (HP)	22+05 / 148.1' LT	76.3'	PRIMARY	76.1'	0.3'	REMOVE	ULTIMATE
3140	TREE (HP)	27+08 / 195.1' LT	77.5'	PRIMARY	76.8'	0.8'	REMOVE	ULTIMATE
3141	TREE (HP)	27+67 / 191.5' LT	78.0'	PRIMARY	76.9'	1.1'	REMOVE	ULTIMATE
3142	TREE (HP)	91+69 / 276.5' RT	116.7'	APPROACH	112.5'	4.2'	REMOVE	ULTIMATE
3143	TREE (HP)	92+55 / 409.1' RT	121.5'	APPROACH	115.0'	6.5'	REMOVE	ULTIMATE
3144	TREE (HP)	93+04 / 266.1' RT	119.2'	APPROACH	116.4'	2.8'	REMOVE	ULTIMATE
3145	TREE (HP)	93+89 / 259.4' RT	120.3'	APPROACH	118.9'	1.4'	REMOVE	ULTIMATE
3146	TREE (HP)	93+76 / 291.3' LT	121.5'	APPROACH	118.5'	3.0'	REMOVE	ULTIMATE
3147	TREE (HP)	95+30 / 531.5' LT	129.5'	TRANSITIONAL	124.0'	5.5'	REMOVE	ULTIMATE
3148	TREE (HP)	96+04 / 483.1' LT	126.1'	APPROACH	125.2'	0.9'	REMOVE	ULTIMATE
3149	TREE (HP)	98+73 / 235.5' LT	136.9'	APPROACH	133.1'	3.8'	REMOVE	ULTIMATE
3150	TREE (HP)	101+72 / 548.7' LT	161.6'	APPROACH	141.9'	19.7'	REMOVE	ULTIMATE
3151	TERRAIN	20+41 / 179.1' LT	76.1'	PRIMARY	75.8'	0.3'	REMOVE	ULTIMATE

**LEGEND**

- FAR PART 77 TERRAIN PENETRATIONS
- FAR PART 77 TREE PENETRATIONS
- OBSTRUCTION, SEE PLAN VIEW

- NOTES:**
- (HP) = POINT OF HIGHEST PENETRATION.
  - PRIMARY SURFACE WIDTH IS 500'.
  - THERE ARE NO KNOWN HEIGHT RESTRICTIONS.
  - REFER TO INNER PORTION OF THE APPROACH SURFACE (SHEETS 8-11) FOR CLOSE IN OBSTRUCTIONS.
  - USGS QUAD DILLINGHAM (A-7) SQ 2019, ALASKA.
  - AIRPORT AIRSPACE PART 77 SURFACE SHOWN FOR ULTIMATE CONDITION.

**PLAN**

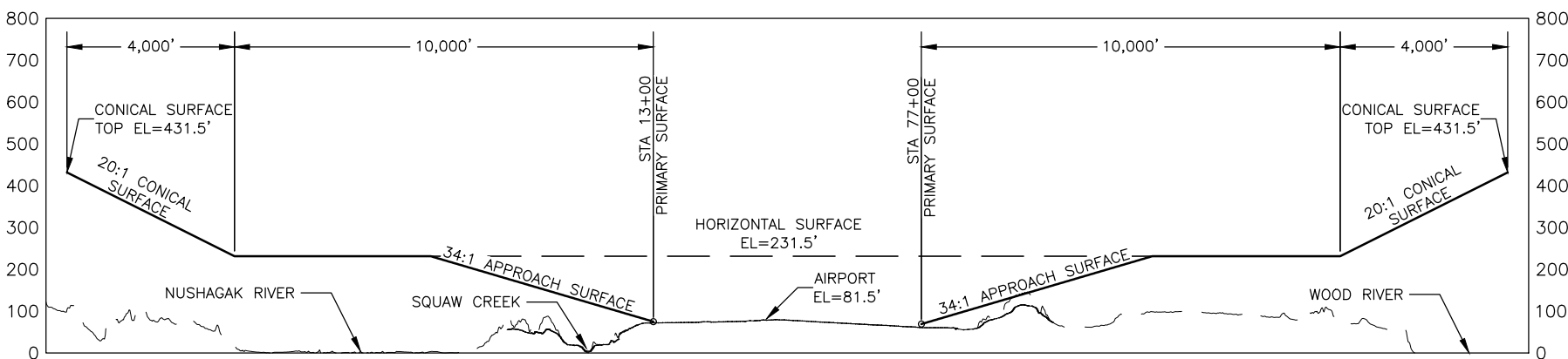

**PROFILE**

<b>STATE OF ALASKA</b> <b>DEPARTMENT OF TRANSPORTATION</b> <b>AND PUBLIC FACILITIES</b> <b>CENTRAL REGION</b>		
<b>DILLINGHAM AIRPORT</b> DILLINGHAM, ALASKA AIRPORT LAYOUT PLAN		DATE: 2/17/2023 SHEET: 19 OF 21
BY	DATE	REVISION

- NOTES:**
- THE INFORMATION PROVIDED IS BASED ON THE DOT&PF AIRPORT PROPERTY PLAN DATED 12/11/2014.
  - TRACT VI WAS NOT INCLUDED AS PART OF THE DILLINGHAM AIRPORT PROPERTY PLAN SURVEY. TRACT VI, WHICH IS A PORTION OF A PUBLIC ROAD RIGHT-OF-WAY, WAS DEDICATED TO THE PUBLIC AND THE CITY OF DILLINGHAM BY MISSION SUBDIVISION, FILED AS PLAT NO. 81-8.
  - TRACT II, PARCEL K WAS NOT INCLUDED AS PART OF THE DILLINGHAM AIRPORT PROPERTY PER DILLINGHAM AIRPORT PROPERTY PLAN. TRACT II, PARCEL K KANAKANAK ROAD ROW.

PROPERTY STATUS								
TRACT	PARCEL	INTEREST	GRANTOR	GRANTEE	PARCEL SIZE (AC)	DATE ACQUIRED	RECORDED DOC NO.	ACQUIRED AIP NO.
I	-	FEE SIMPLE	STATE OF ALASKA, DNR	STATE OF ALASKA, DOT/PF	55.63 ±	5/19/1958	PAT. 1139790	
II	A	FEE SIMPLE 50-85-0054	USA, BLM	STATE OF ALASKA	6.88 ±	11/28/1984	BK 29 PG 27	
	B	FEE SIMPLE-PATENT 50-85-0054	USA, BLM	STATE OF ALASKA	7.36 ±	11/28/1984	BK 29 PG 27	
	C	A & H EASEMENT & ROW	RALPH SORENSEN	STATE OF ALASKA, DOT/PF	4.44 ±	3/15/1985	BK 29 PG 412	
	D	FEE SIMPLE 50-85-0054	USA, BLM	STATE OF ALASKA	1.62 ±	11/28/1984	BK 29 PG 27	
	E1	FEE SIMPLE	RALPH SORENSEN	STATE OF ALASKA, DOT/PF	5.15 ±	5/23/1985	BK 29 PG 756	
	E2	FEE SIMPLE	RALPH SORENSEN	STATE OF ALASKA, DOT/PF	0.0005 ±	5/23/1985	BK 29 PG 756	
	F1	FEE SIMPLE	RALPH SORENSEN	STATE OF ALASKA, DOT/PF	1.95 ±	5/23/1985	BK 29 PG 756	
	F2	A & H EASEMENT & AIR RIGHTS	BIA FOR RALPH SORENSEN ET. AL.	STATE OF ALASKA, DOT/PF	3.67 ±	8/13/1985	BK 30 PG 76	
	G	FEE SIMPLE	BERNARD J. WHEELER, JR ET. AL.	STATE OF ALASKA, DOT/PF	2.15 ±	8/2/1985	BK 30 PG 35	
	H	FEE SIMPLE	USA, BLM	STATE OF ALASKA	2.66 ±	11/28/1994	BK 29 PG 27	
	I	A & H EASEMENT & AIR RIGHTS	BIA FOR KATIE TIMMERMAN	STATE OF ALASKA, DOT/PF	1.68 ±	3/15/1985	BK 29 PG 407	
	J	FEE SIMPLE	KATIE TIMMERMAN	STATE OF ALASKA, DOT/PF	1.52 ±	1/8/1985	BK 29 PG 182	
	L	FEE SIMPLE 50-85-0054	USA, BLM	STATE OF ALASKA	5.53 ±	11/28/1984	BK 29 PG 27	
III	-	FEE SIMPLE	USA, BLM	STATE OF ALASKA	406.03 ±	8/28/1981	BK 24 PG 350	
IV	A	FEE SIMPLE	R. ARMSTRONG, ET. AL.	STATE OF ALASKA, DOT/PF	4.84 ±	6/18/1982	BK 25 PG 627	
	B	FEE SIMPLE	MARTIN JOHNSON	STATE OF ALASKA, DOT/PF	1.14 ±	1/11/1982	BK 25 PG 29	
	C	FEE SIMPLE	CHOGGIUNG LTD.	STATE OF ALASKA, DOT/PF	0.25 ±	4/6/1993	BK 40 PG 336	
	D	FEE SIMPLE	HEIRS OF MICKEY LOPEZ	STATE OF ALASKA, DOT/PF	0.53 ±	11/21/1984	2011-000266-0	
V	A	FEE SIMPLE	USA, BLM 50-85-0054	STATE OF ALASKA, DOT/PF	6.87 ±	11/7/1984	BK 29 PG 27	
	B	FEE SIMPLE	NELS J ANDERSON	STATE OF ALASKA, DOT/PF	0.87 ±	9/12/1985	BK 30 PG 264	
	C	A & H EASEMENT & AIR RIGHTS	BIA FOR NELS J ANDERSON	STATE OF ALASKA, DOT/PF	1.24 ±	9/27/1985	BK 30 PG 763	
VII	-	A & H EASEMENT & ROW	USA, BLM	STATE OF ALASKA, USA	23.64 ±	5/2/1972	BK 21 PG 274	
VIII	A	FEE SIMPLE	CHOGGIUNG LTD. & BRISTOL BAY NATIVE CORP.	STATE OF ALASKA, DOT/PF	21.32 ±	8/3/1984	BK 25 PG 535	
	B	FEE SIMPLE	CHOGGIUNG LTD. & BRISTOL BAY NATIVE CORP.	STATE OF ALASKA, DOT/PF	42.89 ±	8/3/1984	BK 25 PG 535	
	C	FEE SIMPLE	NELS JOHNSON	STATE OF ALASKA, DOT/PF	30.56 ±	9/3/1982	BK 25 PG 700	
	D	A & H EASEMENT & ROW	BIA FOR NELS JOHNSON	STATE OF ALASKA, DOT/PF	4.94 ±	9/3/1982	BK 25 PG 702	
IX	-	A & H EASEMENT & ROW	CHOGGIUNG LTD.	STATE OF ALASKA, DOT/PF	3.11 ±	4/21/1993	BK 40 PG 342	
X	-	FEE SIMPLE	KUZAKIN, ROEHL, ET. AL.	STATE OF ALASKA, DOT/PF	2.32 ±	9/9/1985	BK 30 PG 191-251	
XI	-	A & H EASEMENT & ROW	S OF A, DNR ADL 207091	STATE OF ALASKA, DOT/PF	18.70 ±	11/5/1984	BK 28 PG 940	
XII	-	FEE SIMPLE; A & H EASEMENT	TBD	STATE OF ALASKA, DOT/PF	7.88 ±	TBA	TBD	
XIII	A	FEE SIMPLE	TBD	STATE OF ALASKA, DOT/PF	0.41 ±	TBA	TBD	
	B	FEE SIMPLE	TBD	STATE OF ALASKA, DOT/PF	1.89 ±	TBA	TBD	
	C	FEE SIMPLE	TBD	STATE OF ALASKA, DOT/PF	0.81 ±	TBA	TBD	
XIV	-	FEE SIMPLE; A & H EASEMENT	TBD	STATE OF ALASKA, DOT/PF	35.68 ±	TBA	TBD	

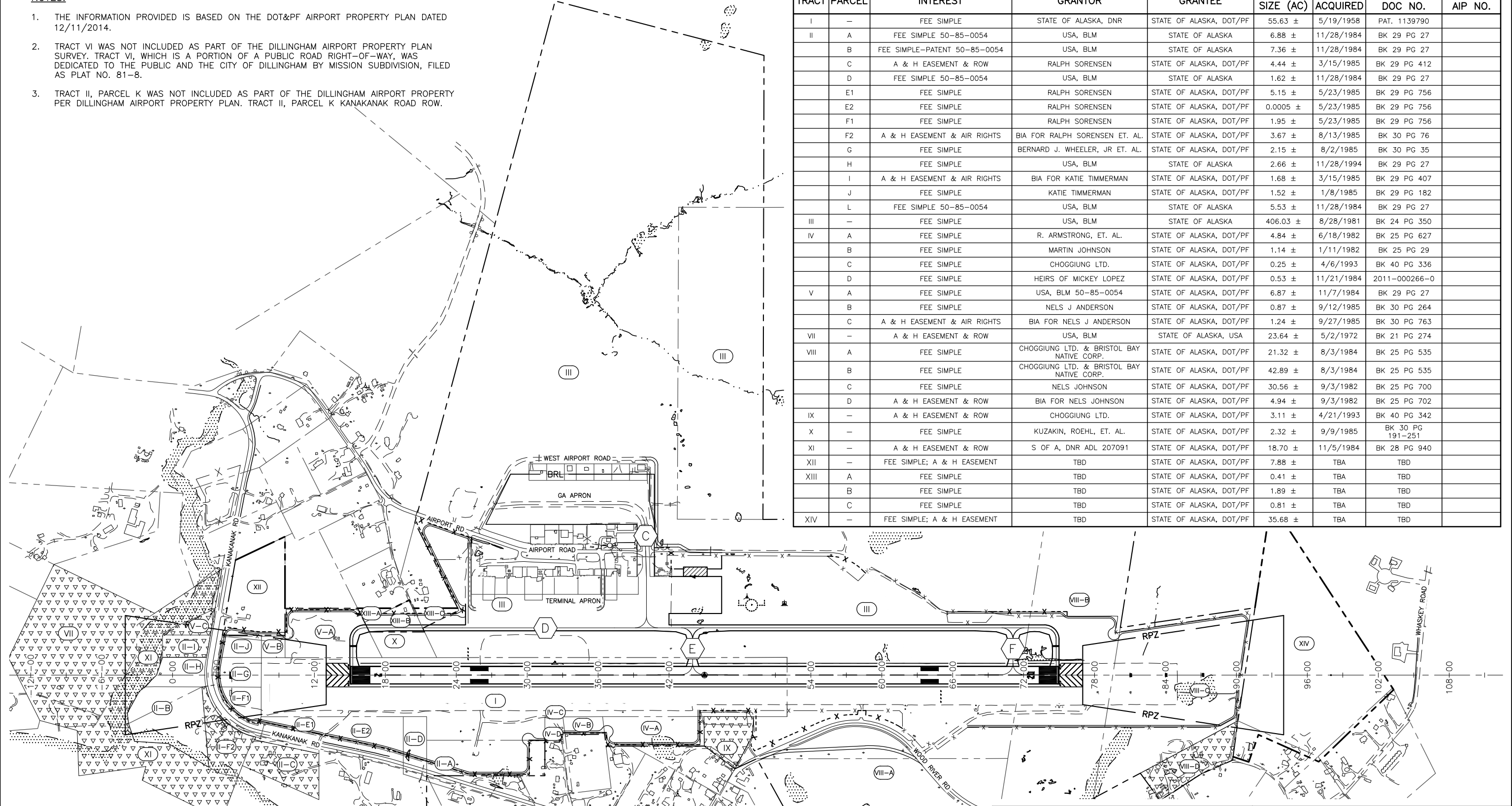

- PROPERTY LEGEND**
- (T-P) TRACT AND PARCEL IDENTIFIER
  - EXISTING PROPERTY BOUNDARY
  - ULTIMATE PROPERTY BOUNDARY
  - ▲▲▲▲ A&H EASEMENT INTEREST

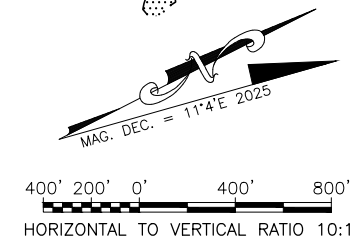





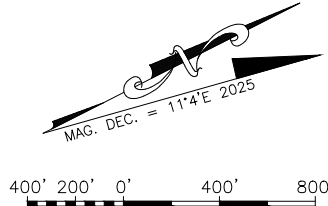

STATE OF ALASKA <b>DEPARTMENT OF TRANSPORTATION          AND PUBLIC FACILITIES</b> CENTRAL REGION		DATE:	2/17/2023
		SHEET:	20
		OF	
PROPERTY MAP		BY	DATE
		REVISION	

Designed By: MMW/RLC  
 Drawn By: MMW/RLC  
 Checked By: CLB  
 Date Plotted: 2/17/2023, 12:42 PM  
 Project Number: 21-1003-01  
 File Name: Z:\proj\sect\2020\_01\DOI\_C.BLG\_AWP\sect\Civil\ACAD\ALP-DUG-Land Use.dwg

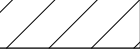
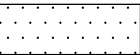
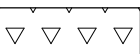
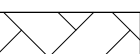

**PROPERTY LEGEND**

	AVIATION USE		EXISTING PROPERTY BOUNDARY
	REVENUE SUPPORT AREA		ULTIMATE PROPERTY BOUNDARY
	NON-AVIATION REVENUE AREA		
	RESIDENTIAL AREA		
	AVIGATION HAZARD EASEMENT		
	AVIATION RESERVE		
	COMMERCIAL MIXED USE		

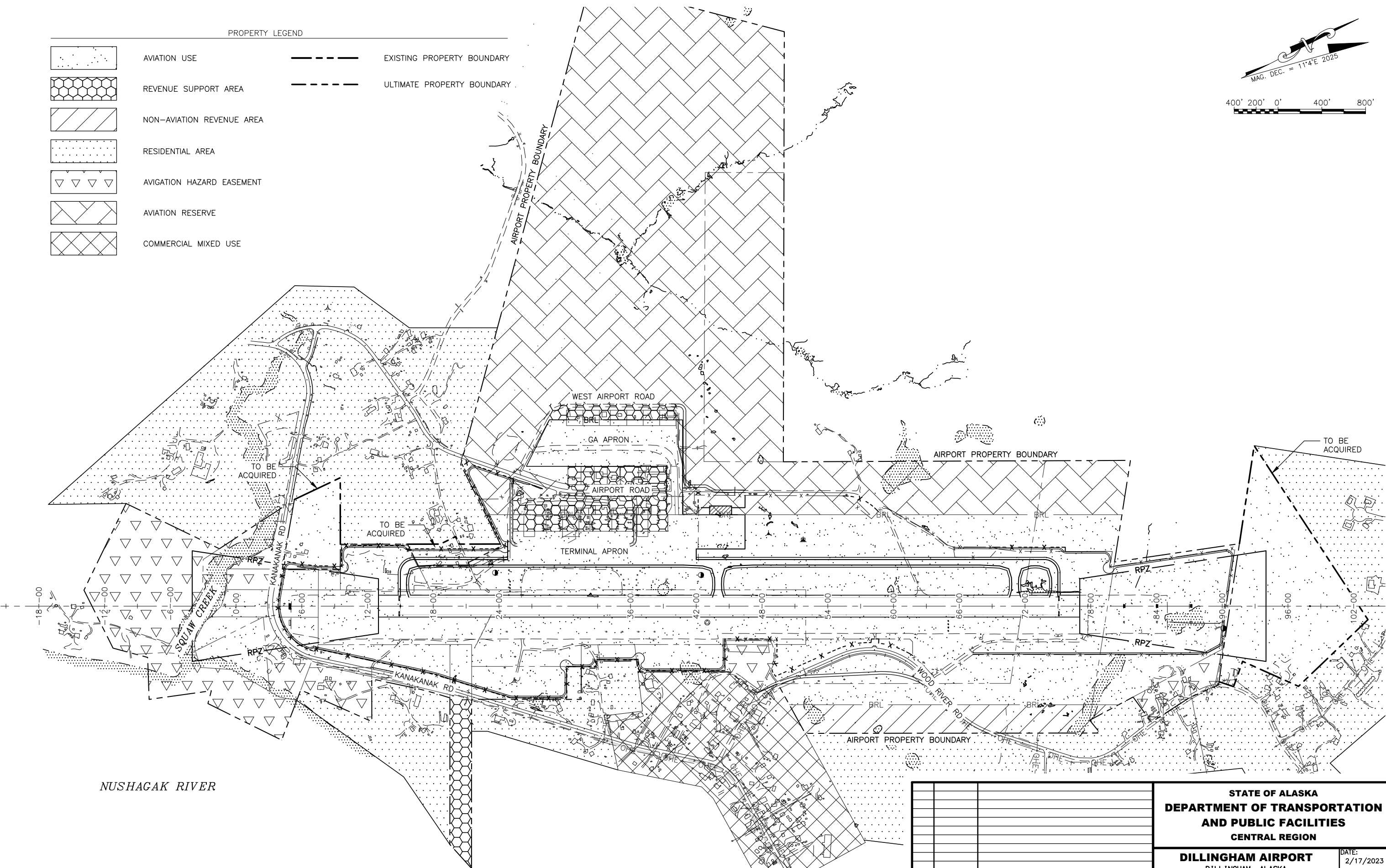

NUSHAGAK RIVER

BY	DATE	REVISION

**STATE OF ALASKA**  
**DEPARTMENT OF TRANSPORTATION**  
**AND PUBLIC FACILITIES**  
**CENTRAL REGION**

**DILLINGHAM AIRPORT**  
 DILLINGHAM, ALASKA  
 AIRPORT LAYOUT PLAN

LAND USE

DATE: 2/17/2023
SHEET: 21
OF 21



## **Appendix B: Demand-Capacity Analysis**

# Demand Capacity Analysis

## Dillingham Airport Master Plan Update

Project No. CFAPT00353/ AIP 3-02-0078-017-2018

Prepared for:



Alaska Department of Transportation & Public Facilities  
4111 Aviation Avenue  
Anchorage, Alaska 99502

Prepared by:

R&M Consultants, Inc.  
9101 Vanguard Drive  
Anchorage AK, 99507

December 2021

The preparation of this document is supported in part with financial assistance through the Airport Improvement Program from the Federal Aviation Administration (AIP Grant Number 3-02-0078-017-2018) as provided under Title 49 USC § 47104. The contents do not necessarily reflect the official views or policy of the FAA. Acceptance of this report by the FAA does not in any way constitute a commitment on the part of the United States to participate in any development depicted therein, nor does it indicate that the proposed development is environmentally acceptable in accordance with the appropriate public laws.

## Table of Contents

Introduction .....	3
Data Sources .....	3
Methodology.....	4
Average Hourly Capacity .....	5
Inputs .....	5
Outputs .....	7
Annual Service Volume .....	8
Inputs .....	8
Outputs .....	8
Summary .....	9
References .....	10

### List of Figures

Figure 1: 5010 Operations Count at DLG (2018).....	4
Figure 2: TranStats: DLG (2019) .....	9

### List of Tables

Table 1: DLG Operating Fleet Mix by Aircraft Classification.....	5
Table 2: FAA Aircraft Classifications.....	6
Table 3: Average Runway Occupancy and Approach Speeds .....	6
Table 4: Arrival-Arrival Separation Requirements .....	7
Table 5: Departure-Departure Separation Requirements .....	7
Table 6: Hourly Capacity at DLG.....	8

### List of Acronyms

ACRP	Airport Cooperative Research Program
AMP	Airport Master Plan
ASV	Annual Service Volume
BTS	Bureau of Transportation Statistics
DLG	Dillingham Airport
DOT&PF	Department of Transportation and Public Facilities
FAA	Federal Aviation Administration
FSS	Flight Service Station
GA	General Aviation
IMC	Instrument Meteorological Conditions
NPIAS	National Plan of Integrated Airport Systems
RW	Runway
VMC	Visual Meteorological Conditions

## Introduction

The following Demand Capacity Analysis for Dillingham Airport (DLG) supports the State of Alaska Department of Transportation & Public Facilities' (DOT&PF) Dillingham Airport Master Plan (AMP) update.

The purpose of this analysis is to determine:

1. DLG's hourly and annual capacity to facilitate air traffic
2. How current demand relates to capacity

Regarding hourly capacity, this analysis estimates that DLG can accommodate 68 mixed operations (arrivals and departures) during Visual Meteorological Conditions (VMC) and 42 mixed operations during Instrument Meteorological Conditions (IMC).

Annual capacity at DLG is estimated at 118,530 operations. On an annual basis, demand is an estimated 20.1% of capacity, although demand increases to 78% of capacity in July—the peak month.

The following sections discuss:

1. Data sources used to determine demand and capacity
2. Methodology used
3. Inputs and outputs associated with estimating DLG's hourly and annual capacities.

## Data Sources

The following data sources were used in determining DLG's demand and capacity.

### **T-100 Dataset**

The Bureau of Transportation Statistics (BTS) T-100 data from 2019<sup>1</sup> was used for the DLG Aviation Activity Forecast. This was used to determine the monthly and annual operations breakdown by aircraft classification. These numbers applied to commercial operations reported by air carriers.

### **5010 Master Record**

Since the T-100 only shows reported commercial operations, the 5010 Master Record was consulted to estimate general aviation (GA) operations. The significant limitation with this data source is that the reported number of GA operations has not been updated since 2007. Operations data in the 5010 are considered less reliable for non-towered airports with fewer than 100,000 enplanements (e.g. DLG), due to being updated less frequently. The 5010 Master Record was accessed for DLG via the Airport Data and Information Portal (ADIP).<sup>2</sup> See Figure 1.

---

<sup>1</sup> "T-100 Domestic Segment," Bureau of Transportation Statistics, 2010-2018.

<sup>2</sup> "(DLG) Dillingham," Airport Data and Information Portal (ADIP), Federal Aviation Administration, October 7, 2021.

Annual Operations	
Air Carrier:	1,323
Air Taxi:	36,489
General Aviation Local:	2,083
General Aviation Itinerant:	10,986
Military:	11
TOTAL OPERATIONS:	50,892
Operations for 12 Months Ending:	12/31/2018

**Figure 1: 5010 Operations Count at DLG (Accessed 2018)**

### **BTS TranStats**

BTS TranStats was used to determine the average amount of delay experienced at DLG in 2019.

### **Spreadsheet Capacity Model**

This Excel spreadsheet model was provided by FAA and is used to calculate the hourly aircraft operations capacity of an airport.

### **Annual Service Volume (ASV) Estimation Model**

This Excel spreadsheet model was provided by FAA and is used to calculate the annual aircraft operations capacity of an airport.

## Methodology

Guidance for estimating airport capacity was provided in the Airport Cooperative Research Program Report 79 (ACRP 79), *Evaluating Airfield Capacity* and the accompanying *Prototype Airfield Capacity Spreadsheet Model User's Guide*.

ACRP 79 was preferred over the 1983 AC 150/5060-5, *Airport Capacity and Delay*, since the latter is more suited to large airports with multiple runways to allow some separation of operations by aircraft class—as opposed to DLG where all operations utilize Runway 1-19. AC 150/5060-5 also has assumptions built into the lookup tables that limit planners' ability to modify capacity calculations when airport variables deviate from those assumptions. For airports like DLG, where utility aircraft comprise most of the fleet mix, AC 150/5060-5 does not adequately capture the actual capacity.

This analysis determines “maximum sustainable throughput” to compare demand and capacity at DLG. Determining maximum sustainable throughput answers the question, “How many aircraft operations can an airfield reasonably accommodate in a given period of time when there is a continuous demand for service during that period?”<sup>3</sup>

DLG capacity estimates include Annual Service Volume (ASV) and average hourly capacity levels. These were estimated using the spreadsheet models developed for ACRP Report 79, *Evaluating Airport Capacity*. ASV utilizes a simpler spreadsheet model that accounts for differences in runway use, aircraft mix, and weather conditions expected to occur over a typical year, whereas the average hourly capacity estimate focuses on the maximum number of operations that DLG can facilitate in one hour.

<sup>3</sup> ACRP Report 79, *Evaluating Airfield Capacity*, The National Academies Press, (2012): 3.

Since robust data were not available to determine the exact fleet mix of GA aircraft when calculating the total fleet mix at DLG, two GA scenarios were tested for sensitivity analysis. In the first scenario, all GA aircraft listed in the 5010 were assumed to be single engine aircraft with a maximum takeoff weight (MTOW) less than 12,500 pounds. In the second scenario, review of the most recent aerial imagery of DLG’s GA apron revealed approximately 13% of the aircraft to be twin-engine aircraft, assumed to have an MTOW less than 12,500 pounds. Both mixes were used in the spreadsheet model to determine whether there was a significant difference in hourly capacity.

## Average Hourly Capacity

Average hourly capacity refers to the number of operations an airport can sustainably facilitate each hour.<sup>4</sup>

Runway (RW) 1-19 is the only runway at DLG, so there is no separation of Class A-D aircraft, which use RW 1-19 for 100% of DLG operations. Some smaller aircraft with tundra tires use the gravel embankment to the adjacent northwest of RW 1-19 to land, although this is not its intended or permitted use. As such, this area is not considered to increase hourly capacity.

RW 1-19 can be accessed via perpendicular taxiways A or B. Since there is no parallel taxiway, aircraft must taxi on the runway and turn around before taking off. This is inefficient and can add to delays, particularly during the summer fishing season when DLG experiences its highest air traffic volumes.

## Inputs

The following variables listed in ACRP 79,<sup>5</sup> were determined for DLG and input into the FAA Airfield Capacity Spreadsheet Model for single-runway airports.

### **Aircraft Fleet Mix**

Table 1 shows the operating fleet mix at DLG by aircraft classification under the first GA aircraft scenario, with 100% of the GA aircraft in the Small-S category. The second scenario, with 87% Small-S and 13% Small-T GA aircraft, resulted in the total Small-S and Small-T operations percentages at 75.4% and 11.9%, respectively. The remaining categories were not affected. Table 2 describes the aircraft categories used in the spreadsheet model.

**Table 1: DLG Operating Fleet Mix by Aircraft Classification (2019)**

Aircraft Class New Category	Small - S	Small - T	Small +	Large-Turboprop	Large-Jet	Large-757	Heavy
Previous FAA Category	A	B	C	C	C	C	D
Percentage of Operations (Scenario 1)	81.4%	5.9%	0.0%	9.2%	3.5%	0.0%	0.0%
Percentage of Operations (Scenario 2)	75.4%	11.9%	0.0%	9.2%	3.5%	0.0%	0.0%

<sup>4</sup> ACRP Report 79, *Evaluating Airfield Capacity*, The National Academies Press, (2012): 3.

<sup>5</sup> Ibid, 49.

**Table 2: FAA Aircraft Classifications**

<b>Aircraft Classification</b>	<b>Small - S</b>	<b>Small - T</b>	<b>Small +</b>	<b>Large-TP</b>	<b>Large-Jet</b>	<b>Large-757</b>	<b>Heavy</b>
<b>New Category</b>							
<b>Previous FAA Category</b>	A	B	C	C	C	C	D
<b>Maximum Gross Takeoff Weight (MTOW)</b>	Less than 12,500 lbs. (Single Engine)	Less than 12,500 lbs. (Twin Engine)	Between 12,500 lbs. and 41,000 lbs.	Between 41,000 lbs. and 255,000 lbs.	Between 41,000 lbs. and 300,000 lbs.	Boeing 757 Series	More than 300,000 lbs.

**VMC vs. IMC**

Excluding no-fly conditions, VMC occurs 81.72% of the time and IMC occurs 18.28% of the time at DLG. Wind data observations at DLG from 2011-2020 were used to determine these percentages.

**Arrival runway occupancy time & approach speeds**

Average runway occupancy times were separated by aircraft class (Table 3).

**Table 3: Average Runway Occupancy and Approach Speeds**

<b>Aircraft Class New Category</b>	<b>Small - S</b>	<b>Small - T</b>	<b>Small +</b>	<b>Large-Turboprop</b>	<b>Large-Jet</b>	<b>Large-757</b>	<b>Heavy</b>
<b>Arrival RW Occupancy Time (Seconds)</b>	32	40	42	45	46	51	55
<b>Average Approach Speeds (Knots)</b>	90	100	120	130	135	140	150

**Runway exit availability**

There are two available runway exits.

**Type of parallel taxiway (i.e. full, partial, or none)**

There is no parallel taxiway.

**Availability of an air traffic control tower**

There is no air traffic control tower.

**Runway crossings**

There are no runway crossings.

**Percent of touch-and-go activity**

0% touch-and-go activity was assumed.

**Length of common approach**

The common approach length used was 12 nautical miles.



**Departure-arrival separation**

Departure-arrival separation inputs were 3.5 nautical miles during VMC and 5 nautical miles during IMC.

**Arrival gap spacing buffer**

The arrival gap spacing buffer input was 10 nautical miles.

**Departure hold buffer**

Departure hold buffer was kept at the spreadsheet default

**Arrival-arrival & departure-departure separation requirements**

The default values were used for arrival-arrival and departure-departure separation requirements (Tables 4 and 5).

**Table 4: Arrival-Arrival Separation Requirements**

Trailing Aircraft	Leading Aircraft	Distance in Nautical Miles	
		VMC	IMC
Small-S --- Heavy	Small-S, Small-T	1.9	3.0
Small-S --- Small+	Small+	1.9	3.0
Large --- Heavy	Small+	1.9	3.0
Small-S --- Small+	Large-TP, Large-Jet	2.7	4.0
Large --- Heavy	Large-TP, Large-Jet	1.9	3.0
Small-S --- Small+	Large-757	3.7	5.0
Large --- Heavy	Large-757	2.7	4.0
Small-S --- Small-T	Heavy	4.6	6.0
Small+ --- 757	Heavy	3.6	5.0
Heavy	Heavy	2.7	4.0

**Table 5: Departure-Departure Separation Requirements**

Trailing Aircraft	Leading Aircraft	Time in Seconds	
		VMC	IMC
Small-S --- Small+	Small-S --- Small+	35	60
Large-TP --- Large-757	Small-S --- Small+	45	60
Heavy	Small-S --- Small+	50	60
Small-S --- Small+	Large-TP, Large-Jet	80	80
Large --- Heavy	Large-TP, Large-Jet	60	60
Small-S --- Large-Jet	Large-757, Heavy	120	120
Large-757, Heavy	Large-757, Heavy	90	90

**Outputs**

Given the inputs used, Table 6 shows the hourly capacity at DLG. The capacity changes based on the given meteorological conditions (i.e. VMC and IMC) and type of operations (i.e. arrivals only, departures only, and mixed operations). Scenarios 1 and 2, depicting different GA aircraft fleet mixes, did not affect hourly capacity at DLG.

**Table 6: Hourly Capacity at DLG**

	<b>VMC</b>	<b>IMC</b>	<b>Average</b>
<b>Arrivals Only Capacity</b>	3	3	3
<b>Arrivals Capacity (including TNG's)</b>	3	3	3
<b>Departures Only Capacity</b>	87	58	81
<b>Mixed Ops – Departure Capacity (including TNG's)</b>	64	39	60
<b>Total Mixed Operations Capacity</b>	68	42	63
<b>Arrivals Percentage</b>	5%	7%	5%

## Annual Service Volume

Annual Service Volume (ASV) refers to an airport's capacity to facilitate operations over a span of one year.<sup>6</sup>

### Inputs

The following variables were determined for DLG and input into the ASV estimation spreadsheet model.

#### **Annual Demand**

Annual demand was 23,841, based on the 2019 T-100 operations for DLG and the 5010 Master Record that showed the estimated general aviation operations. Using 2019 operations ensures consistency with the Aviation Forecast report and is a better source than 2020 data for analysis, since COVID-19 impacts significantly affected 2020 operations.

#### **Average Peak Month Daily Demand**

July is the peak month at DLG with an estimated 2019 demand of 7,750, based on the DLG Flight Service Station (FSS) estimate of 250 average daily operations in July (i.e. 250 operations \* 31 days).

#### **Average Peak Hour Demand**

The estimated average peak hour demand is 10.42, based on dividing the average peak month daily demand by 24 hours. A specific average peak hour demand was not provided.

#### **VMC vs. IMC Occurrence and Hourly Capacity**

Using the average Hourly Capacity inputs and outputs, VMC occurs 81.72% of the time and IMC occurs 18.28%. VMC hourly capacity is 68 operations, and IMC hourly capacity is 42 operations.

#### **Maintenance**

Maintenance activities, such as snow removal, painting, and crack sealing lower the total time that a runway can be used for operations. A 10% reduction in annual service volume was assumed. It is possible that the estimated maintenance reduction is low, affecting the calculated annual capacity.

### Outputs

Given the input values used, the estimated ASV is 118,530. The ASV spreadsheet model shows 131,700 annual operations since the 10% operations reduction for maintenance activities was not included. With

<sup>6</sup> ACRP Report 79, *Evaluating Airfield Capacity*, The National Academies Press, (2012): 3.

an annual demand of 23,841 operations, the annual demand capacity ratio is approximately 0.201, meaning that current demand is 20.1% of available capacity.

Due to the highly seasonal nature of DLG operations, this capacity estimate can be somewhat misleading. In the winter months, operations may be well below demand, whereas demand may meet or exceed capacity during peak hours in the summer months when the fishing industry is most active. BTS TranStats shows an average delay between 30.22 and 51.11 minutes from 2016 to 2021<sup>7</sup> (Figure 2). Delays indicate capacity exceedance.

To further illustrate, an annual capacity of 118,530 indicates a monthly capacity of approximately 9,878 (i.e. 118,530/12). At 7,750 July operations, July’s demand could, on average, be closer to 78% of capacity.

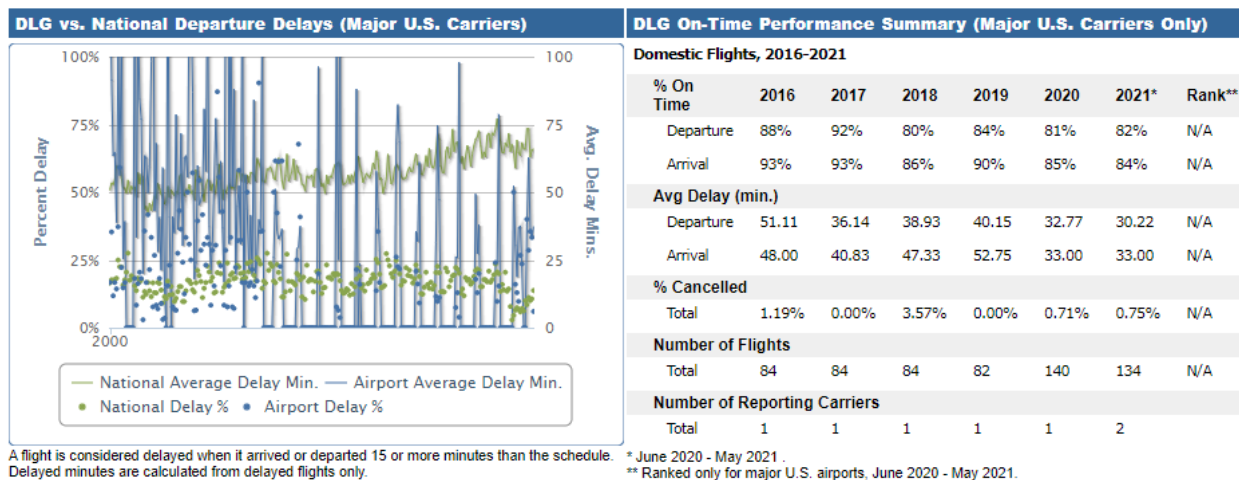

Figure 2: TranStats: DLG (2019)

## Summary

This demand-capacity analysis yielded the average hourly capacity and annual service volume at DLG.

Average hourly capacity analysis estimated that DLG can accommodate 68 mixed operations (arrivals and departures) during Visual Meteorological Conditions (VMC) and 42 mixed operations during Instrument Meteorological Conditions (IMC). Arrivals accounted for 5% and 7% of VMC and IMC hourly capacity, respectively.

Annual capacity at DLG is estimated at 118,530 operations. On an annual basis, demand is an estimated 20.1% of capacity, although demand increases to 78% of capacity in July—the peak month. A limitation of this estimate is that aggregation to yearly or monthly demand does not account for days or hours when demand at DLG may exceed capacity. Airport congestion will affect the movement of fresh fish and game, which is sensitive to delays.

<sup>7</sup> “Dillingham, AK: Dillingham Airport (DLG),” Bureau of Transportation Statistics, December 31, 2019.

## References

- Bureau of Transportation Statistics. 2019. "Dillingham, AK: Dillingham Airport (DLG)." *TransStats*. December. <https://www.transtats.bts.gov/airports.asp?20=E>.
- . 2010-2019. "T-100 Domestic Segment." *United States Department of Transportation*. [https://www.transtats.bts.gov/databases.asp?Z1qr\\_VQ=E&Z1qr\\_Qr5p=N8vn6v10&f7owrp6\\_VQF=D](https://www.transtats.bts.gov/databases.asp?Z1qr_VQ=E&Z1qr_Qr5p=N8vn6v10&f7owrp6_VQF=D).
- Federal Aviation Administration. 2021. "(DLG) Dillingham." *Airport Data and Information Portal (ADIP)*. October 7. <https://adip.faa.gov/agis/public/#/airportData/DLG>.
- Fisher, Leigh; Airport Cooperative Research Program; Transportation Research Board; National Academies of Sciences, Engineering, and Medicine. 2012. *ACRP Report 79, Evaluating Airfield Capacity*. Report, Washington, D.C.: The National Academies Press.

## **Appendix C: DLG RSA Practicability Study**

# Runway Safety Area Practicability Study

## Dillingham Airport Master Plan Update

Project No. CFAPT00353/ AIP 3-02-0078-017-2018

Prepared for:



Alaska Department of Transportation & Public Facilities  
4111 Aviation Avenue  
Anchorage, Alaska 99502

Prepared by:

R&M Consultants, Inc.  
9101 Vanguard Drive  
Anchorage AK, 99507

May 2022

The preparation of this document is supported in part with financial assistance through the Airport Improvement Program from the Federal Aviation Administration (AIP Grant Number 3-02-0078-017-2018) as provided under Title 49 USC § 47104. The contents do not necessarily reflect the official views or policy of the FAA. Acceptance of this report by the FAA does not in any way constitute a commitment on the part of the United States to participate in any development depicted therein, nor does it indicate that the proposed development is environmentally acceptable in accordance with the appropriate public laws.

## Table of Contents

1.0	Introduction .....	1
2.0	Background .....	1
3.0	Purpose and Need.....	1
4.0	Existing Conditions.....	2
4.1	Runway Layout and Facilities .....	2
4.2	Critical Aircraft and Runway Length .....	2
4.3	Runway Safety Area .....	4
4.4	Site Constraints and RSA Impact Considerations.....	6
4.4.1	Community Roads.....	6
4.4.2	Cemetery.....	7
4.4.3	Utilities .....	8
4.4.4	Airport Fence.....	8
4.4.5	Land Use and ROW Considerations .....	8
4.4.6	Airspace Obstructions .....	10
4.4.7	Wetlands and Environmental Background Information .....	10
4.4.8	Geology and Soil Conditions .....	12
4.5	Runway Line of Sight and Parallel Taxiway .....	12
4.5.1	LOS Deficiency.....	12
4.5.2	Parallel Taxiway.....	13
4.5.3	LOS Correction .....	13
4.6	Visual and Navigation Aids, Approach Procedures, and Airport Lighting.....	17
4.6.1	Visual and Navigation Aids.....	17
4.6.2	Approach Procedures.....	17
4.6.3	Airport Lighting .....	18
5.0	RSA Improvement Alternatives.....	18
5.1	Alternative 1: Offset RW 150' West.....	19
5.1.1	Description .....	19
5.1.2	Airport Impacts .....	19
5.1.3	Roadway and Utility Impacts .....	20
5.1.4	Cemetery Impacts .....	20
5.1.5	ROW, Obstruction, and LOS Impacts .....	20
5.1.6	Environmental Impacts and Geology.....	21



---

5.1.7	Costs.....	22
5.2	Alternative 2: Offset RW 150' West, Shift RW 1 Threshold 400' North.....	22
5.2.1	Description.....	22
5.2.2	Airport Impacts.....	22
5.2.3	Roadway and Utility Impacts.....	23
5.2.4	Cemetery Impacts.....	23
5.2.5	ROW, Obstruction, and LOS Impacts.....	23
5.2.6	Environmental Impacts and Geology.....	23
5.2.7	Cost.....	23
5.3	Alternative 3: Expand Existing RSA.....	24
5.3.1	Description.....	24
5.3.2	Airport Impacts.....	24
5.3.3	Roadway and Utility Impacts.....	24
5.3.4	Cemetery Impacts.....	24
5.3.5	ROW, Obstruction, and LOS Impacts.....	24
5.3.6	Environmental Impacts and Geology.....	25
5.3.7	Cost.....	25
5.4	Alternative 4: No Build, Publish Declared Distances.....	26
5.4.1	Description.....	26
5.4.2	Impacts.....	26
6.0	Alternatives Considered and Deemed Not Feasible.....	27
6.1	EMAS.....	27
6.2	Runway Rotation.....	27
6.3	Airport Relocation.....	27
7.0	Preferred Alternative.....	28
8.0	Constructability and Schedule.....	30

**List of Figures**

Figure 1: Existing RSA Dimensions ..... 4  
Figure 2: Airport Layout ..... 5  
Figure 3: Kananak Road within OFA ..... 6  
Figure 4: Wood River Road within OFA..... 6  
Figure 5: Evergreen Cemetery Photo..... 7  
Figure 6: Evergreen Cemetery Aerial ..... 7  
Figure 7: Land Ownership Map ..... 9  
Figure 8: Wetlands Map..... 11  
Figure 9: Full-Length Parallel Taxiway..... 13  
Figure 10: Partial-Length Parallel Taxiway ..... 13  
Figure 11: LOS Profiles ..... 15  
Figure 12: LOS Correction Sections..... 16  
Figure 13: Airport Diagram with NAVAIDs..... 17  
Figure 14: Alternative 1..... 19  
Figure 15: Alternative 2..... 22  
Figure 16: Alternative 3..... 24  
Figure 17: Alternative 4..... 26  
Figure 18: Half-Width Phasing for RW Raise..... 30

**List of Tables**

Table 1: C-III Fleet Mix Operations (2019) ..... 2  
Table 2: Runway Length Determination ..... 3  
Table 3: Existing and C-III Standard RSA ..... 4  
Table 4: LOS and Parallel TW Cost Estimates..... 14  
Table 5: Alternative 1 Cost Estimate..... 22  
Table 6: Alternative 2 Cost Estimate..... 23  
Table 7: Alternative 3 Cost Estimate..... 25  
Table 8: Alternatives Matrix..... 29  
Table 9: RSA & LOS Combined Costs..... 30

**Appendices**

- Appendix A: Alternative Figures
- Appendix B: Cost Estimates
- Appendix C: Runway Length Determination

### List of Acronyms

A&H	Aviation and Hazard
AAC	Aircraft Approach Category
AC	Advisory Circular
ADEC	Alaska Department of Environmental Conservation
ADG	Airplane Design Group
AIP	Airport Improvement Program
AMP	Airport Master Plan
APDES	Alaska Pollutant Discharge Elimination System
ARFF	Airport Rescue and Firefighting
ASDA	Accelerate-Stop Distance Available
AWOS	Automated Weather Observing System
BIA	Bureau of Indian Affairs
CASC	Crushed Aggregate Surface Course
CFR	Code of Federal Regulations
DLG	Dillingham Airport
DME	Distance Measuring Equipment
DOT&PF	Department of Transportation and Public Facilities
EA	Environmental Assessment
EMAS	Engineered Materials Arresting Systems
FAA	Federal Aviation Administration
FAR	Federal Aviation Regulations
FO	Fiber Optic
FONSI	Finding of no Significant Impact
FSS	Flight Service Station
GA	General Aviation
GPS	Global Positioning System
LDA	Landing Distance Available
LIDAR	Light/Laser Detection and Ranging
LOC	Localizer
LOS	Line-of-Sight
MALSR	Medium Intensity Approach Lighting System with Runway Alignment Indicator Lights
MOS	Modification of Standards
M&O	Maintenance & Operation
NAVAIDs	Navigational Aids
NDB	Non-Directional Beacon
NEPA	National Environmental Policy Act
NPI	Non-Precision Instrument
NPIAS	National Plan of Integrated Airport Systems
ODALS	Omni-Direction Approach Lights
OFA	Object Free Area
PAPI	Precision Approach Path Indicator
PFAS	Perfluoroalkyl and Polyfluoroalkyl Substances
PSS/SS	Scrub-Shrub Wetlands

PEM/EM	Emergent Wetlands
RD	Road
RDC	Runway Design Code
RNAV	Area Navigation
ROFA	Runway Object Free Area
ROW	Right of Way
RPZ	Runway Protection Zone
RSA	Runway Safety Area
RW	Runway
SAWS	Stand Alone Weather Station
SHPO	State Historic Preservation Office
TDG	Taxiway Design Group
TODA	Takeoff Distance Available
TOFA	Taxiway Object Free Area
TORA	Takeoff Run Available
TW	Taxiway
USACE	United States Army Corps of Engineers
USC	United States Code
USGS	United States Geological Survey
VASI	Visual Approach Path Indicator
VOR	Very High Frequency Omni-Directional Range

## 1.0 Introduction

This study evaluates alternatives to improve the Runway (RW) 1/19 Runway Safety Area (RSA) to meet dimensions established by the Federal Aviation Administration (FAA) Advisory Circular (AC) 150/5300-13 *Airport Design*, for the Dillingham Airport (DLG).

This study will discuss RSA improvement alternatives and present a preferred alternative. The study will inform the Alaska Department of Transportation and Public Facilities' (DOT&PF) and FAA's determination of an appropriate RSA configuration.

According to FAA Order 5200.8 *Runway Safety Area Program*, the airport sponsor must document alternatives considered and explain why the preferred alternative was selected over others.

## 2.0 Background

The FAA classifies DLG within the National Plan of Integrated Airport System (NPIAS) as a non-hub, primary commercial service airport. DLG is regulated under Title 14 Code of Federal Regulations Part 139 (14 CFR 139).

DLG is a vital air transportation hub for cargo and passengers between Anchorage and communities in the western Bristol Bay region. DLG was built in the 1950s. Initial construction consisted of a 3,750-foot-long, gravel-surfaced runway and access road. Through the 1960s and 1970s, additional land was acquired; the runway was lengthened; and aprons, facilities, roads, and utilities were added. The runway was lengthened to the northeast by 1,000 feet in 1965. The northeast end of the runway was again extended to its current configuration in 1973. The runway was paved in 1980. A project in the early 2000s (AIP 3-02-0078-1003) included the widening of the safety area by 50 ft on both sides.<sup>1</sup>

This RSA Practicability Study supports the Dillingham Airport Master Plan (AMP) Update. The previous master plan was published in 2005 and included an RSA Practicability Study. An RSA Practicability Study and reevaluation was again performed in 2011. The 2012 Dillingham Airport Improvements project [DOT&PF Project No. 59304/Airport Improvement Program (AIP) No. 3-02-0078-013-2012] incrementally improved the RSA by lengthening and widening it (to 250 feet from centerline on the west side). A runway shift project with further RSA expansion is planned but requires vetting by the findings of this study.

## 3.0 Purpose and Need

Under FAA Order 5200.8 *Runway Safety Area Program*, all RSAs at airports certificated under 14 CFR 139 shall conform to the standards in FAA AC 150/5300-13 *Airport Design* to the extent practicable. DLG does not currently meet the RSA standards for Aircraft Approach Category (AAC)-Airplane Design Group (ADG) C-III and requires additional embankment to meet RSA dimensional standards.

---

<sup>1</sup> Dillingham Airport Improvements (59304) Geotechnical Report, DOT&PF Central Region Materials, February 2012

## 4.0 Existing Conditions

### 4.1 Runway Layout and Facilities

DLG is composed of a single, asphalt-surfaced runway, two aprons, and three taxiways. The runway, designated as RW 1/19, is 150 feet wide and 6,400 feet long. The 790,000-square-foot Terminal Apron connects to RW 1/19 near the midpoint via two 500-foot-long taxiways (TWs), designated TW A and TW B. The General Aviation (GA) Apron is situated to the west of the Terminal Apron and connected by TW C. The GA Apron is surfaced with recycled asphalt pavement. Leaseholder facilities are located along the west edge of the Terminal Apron and around the perimeter of the GA Apron. DLG is a Part 139 Certificated airport, Class I, Airport Rescue and Firefighting (ARFF) Index B. Under CFR certification requirements, it has perimeter airport security fencing and firefighting equipment.

### 4.2 Critical Aircraft and Runway Length

The DLG Aviation Activity Forecast and Critical Aircraft Determination was approved by the FAA on March 24, 2021. The existing critical aircraft category is C-III. Combined operations by group C-III aircraft exceed the 500-operation threshold required for a critical aircraft determination under AC 150/5000-17 *Critical Aircraft and Regular Use Determination*. No single C-III aircraft currently achieves 500 annual operations individually. Their operations must be grouped for the critical aircraft and runway length determination.

By 2040, the ultimate critical aircraft is forecasted to be the Lockheed L-100, which is an AAC/ADG C-IV aircraft. Alaska Airlines also anticipates replacing their Boeing 737-700 operations with 737-800s in 2022-2023 and possibly 737-900s (all C-III aircraft) at an undetermined point in the future. Based on the ultimate critical aircraft need, FAA may approve the planned infrastructure needs based on C-IV standards; however, justification for future projects must be based on actual activity levels at the time the project is requested for development. Changes to the aircraft fleet mix are not anticipated to alter the Runway Design Code (RDC) or runway length determination in the near term. For these reasons, C-III standards and existing aircraft operations were used in this study and runway length determination. An updated aircraft operations summary, critical aircraft and runway length determination should be performed at the time of a future project to verify planned airport dimensions and FAA funding eligibility. Table 1 summarizes C-III group aircraft operations at DLG in 2019 from the FAA-approved DLG AMP Aviation Forecast, originally reported by the Bureau of Transportation Statistics T-100 database.

**Table 1: C-III Fleet Mix Operations (2019)<sup>2</sup>**

AAC - ADG	Aircraft	Annual Operations
C-III	Boeing 737-100/200	15
	Boeing 737-300	175
	Boeing 737-400	88
	Boeing 737-700/700LR/Max 7	264
	McDonnell Douglas DC-9-30	78
	McDonnell Douglas DC9 Super 80/MD81/82/83/88	199
<b>C-III Total</b>		<b>819</b>

<sup>2</sup>Dillingham Airport Master Plan Update Aviation Forecast; Bureau of Transportation Statistics: T-100 Domestic Segment, January-December 2019.

The existing runway length is 6,400 feet, which is longer than required for the critical aircraft. Runway length requirements for group C-III aircraft were determined under AC 150/5325-4B *Runway Length Requirements for Airport Design*. Airport elevation, temperature, aircraft characteristics, aircraft operational weights, and runway gradient were used to extrapolate or adjust runway lengths from aircraft planning manual FAR charts. The FAR runway takeoff length required by the critical aircraft group achieving 500 cumulative annual operations is 6,000 feet.

Table 2 provides a summary of the runway length determination process. The length required by each aircraft in the critical aircraft grouping was determined from manufacturer planning FAR charts utilizing the adjustment factors mentioned above. The runway length must be required by 500 operations by the critical aircraft grouping for FAA funding eligibility. The table is sorted in descending order by runway length required by each aircraft. The runway length was selected from the first column where 500 cumulative operations are achieved. Additional backup documentation on the runway length determination is available in Appendix C.

A reduction in runway length is not popular with airport users. A common request from air carriers during the master plan interviews was to not reduce the runway length. However, FAA will not participate in a runway reconstruction beyond the length determined under AC 150/5325-4B *Runway Length Requirements for Airport Design* and AC 150/5000-17 *Critical Aircraft and Regular Use Determination*. A runway length reduction has the additional benefit of increasing existing embankment length available for the RSA.

**Table 2: Runway Length Determination<sup>3</sup>**

Aircraft	737-200	MD-82	737-400	737-700	DC-9-41 (30)	737-300
<b>Annual Operations</b>	15	199	88	264	78	175
<b>Cumulative Operations</b>	15	214	302	566	644	819
<b>AAC-ADG</b>	C-III	C-III	C-III	C-III	C-III	C-III
<b>MTOW (lbs.)</b>	115,500	149,500	150,000	154,500	114,000	139,500
<b>Operational TOW (lbs.)</b>	112,500	137,000	129,000	132,500	107,500	117,500
<b>Takeoff Length Requirement (ft.)</b>	9,000	6,400	6,200	6,000	6,000	5,700

<sup>3</sup> FAA AC 150/5325-4B; Airplane Characteristics for Airport Planning, various manufactures; See Appendix C

### 4.3 Runway Safety Area

RSA dimension standards are established by the FAA and published in Table 3-5 of AC 150/5300-13A *Airport Design*. The runway safety area is graded and sized to enhance the safety of aircraft that overshoot, underrun, or veer off the runway. It prevents structural damage to the aircraft or injury to occupants and provides accessibility to rescue and firefighting equipment in the case of an accident. The size of the RSA embankment is dependent upon the AAC/ADG of the critical aircraft using the runway. The RSA dimensional standards for a C-III runway are 500 feet wide (centered on the runway centerline), extending 1,000 feet beyond the runway departure end and 600 feet prior to the threshold.

The existing RSA is undersized and non-standard. It is too narrow, is not centered around the runway, and does not extend far enough beyond the south runway end. The current RSA dimensions are 350 feet by 8,000 feet. Its width extends 250 feet west of the runway centerline and only 100 feet to the east. The south RSA length beyond the RW 19 end is 600 feet. The current north RSA length beyond the RW 1 end meets standards at 1,000 feet. See Table 3 and Figure 1 for current RSA dimensions. Because there are no published reduced declared distances at DLG, the runway departure ends are coincident with the runway thresholds.

**Table 3: Existing and C-III Standard RSA<sup>4</sup>**

	Existing	Standard	Meets Standard
<b>RSA Width</b>	350 ft (250 West, 100 ft East of CL)	500 ft	No
<b>RSA Length</b>			
<b>Beyond End of RW 1 (North)</b>	1,000 ft	1,000 ft Beyond Departure End / 600 ft Prior to Threshold	Yes
<b>Beyond End of RW 19 (South)</b>	600 ft	1,000 ft Beyond Departure End / 600 ft Prior to Threshold	No

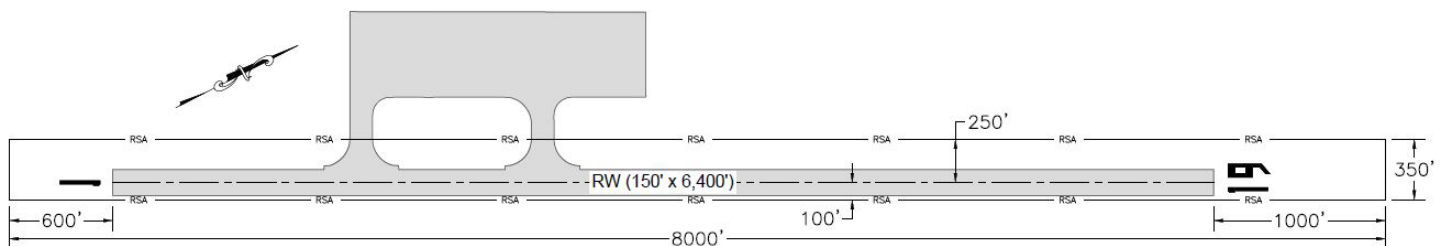

**Figure 1: Existing RSA Dimensions**

<sup>4</sup> Standard C-III RSA dimensions from FAA AC 150/5300-13A, Table 3-5





Figure 2: Airport Layout

#### 4.4 Site Constraints and RSA Impact Considerations

There are several site constraints around the airport that limit the expansion of the existing RSA. The existing airport layout and surrounding site constraints are depicted on Figure 2 and discussed in the following sections.

##### 4.4.1 Community Roads

Dillingham is not on the statewide road system. Kakanak Road is the main road connection to downtown Dillingham. Kakanak Road loops around the south end of the runway and continues along the southeast side of the runway, through airport property and within the Runway Object Free Area (OFA). See Figure 3. There is a significant elevation difference of 18 feet between the south RSA and the road elevation and steep embankment slopes off the RSA end (2 horizontal: 1 vertical).

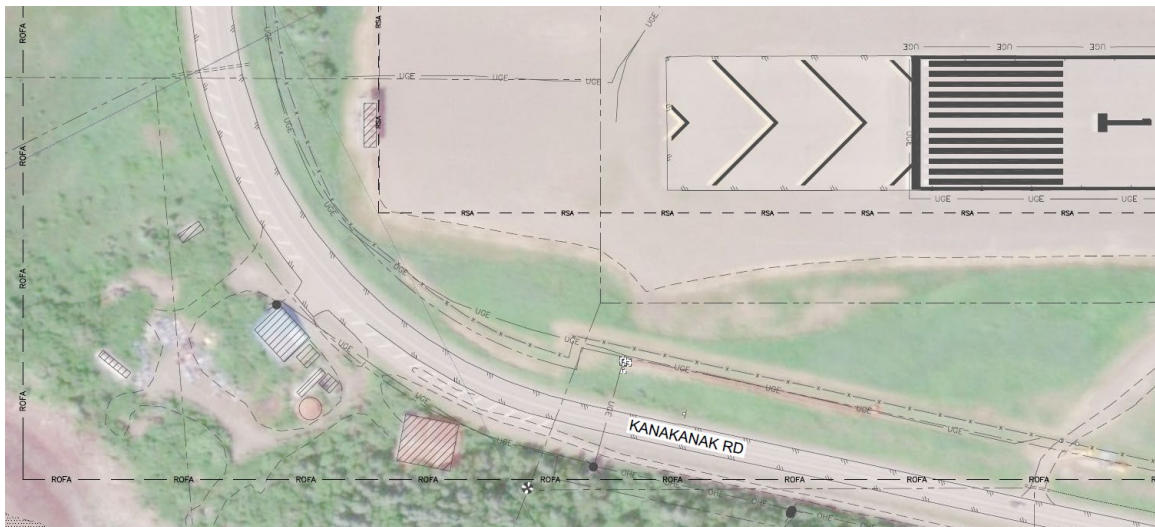

**Figure 3: Kakanak Road within OFA**

A portion of Wood River Road curves towards the east edge of the runway, entering airport property and the OFA (Figure 4). These road constraints limit RSA expansion to the south and east.

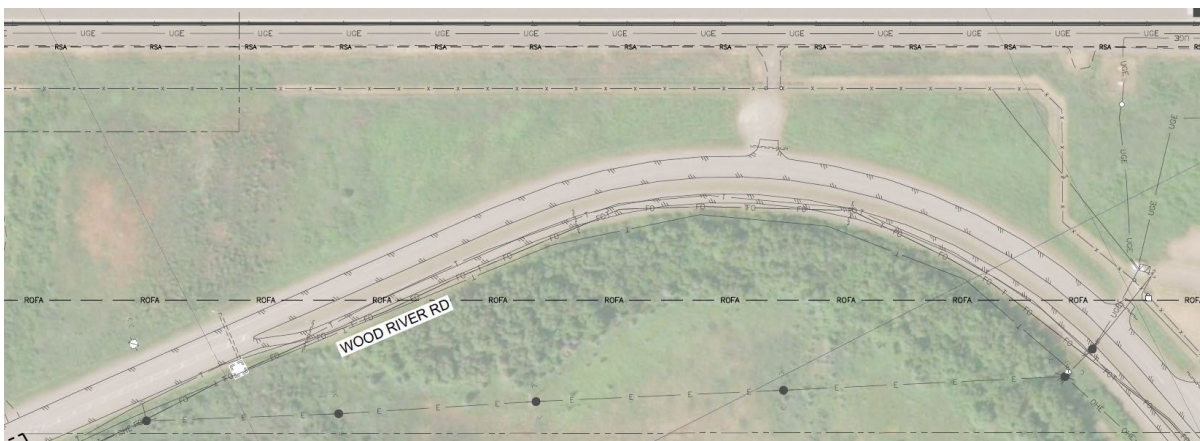

**Figure 4: Wood River Road within OFA**

#### 4.4.2 Cemetery

The Evergreen Cemetery is located on a knoll east of the runway and within the OFA (Figures 5 & 6). The cemetery boundary begins directly east of a road just outside the airport fence. The cemetery is within the airport property interest as fee property and an easement. Airport fee property (Tract I) extends 50 feet east of the fence line into the cemetery. DOT&PF holds an Avigation and Hazard (A&H) and right-of-way (ROW) easement (Tract IV) for the remainder of cemetery land from Choggiung Limited.

The cemetery would be within the RSA if it were expanded to standards around the existing runway. This would require embankment to be built over the current cemetery and necessitate its relocation. There would likely be strong public opposition to relocating the cemetery.

This study recommends that the Evergreen Cemetery be closed to new burials within 100 feet of the existing fence line paralleling the runway except for prearranged interments such as immediate family members, regardless of which RSA alternative is selected. There are alternate sites for new burials. Four other active cemeteries currently exist in Dillingham, and the city has recently purchased land to begin a new cemetery. DOT&PF does not have the outright authority over the portion of the cemetery outside airport fee property and within the easement. Mitigation efforts, including closure would require DOT&PF cooperation with the city, community, and landowner.



Figure 5: Evergreen Cemetery Photo

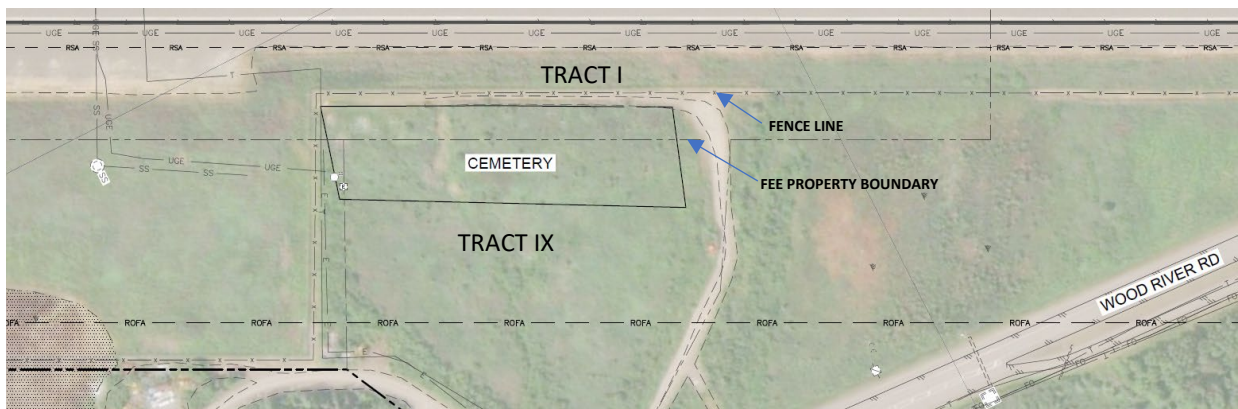

Figure 6: Evergreen Cemetery Aerial

#### 4.4.3 Utilities

There are existing utilities at and around the airport that may be affected by RSA expansion. Nushagak Electric and Telephone Incorporated owns the electrical power and telecommunications lines that run along roadways in the vicinity and provide service to airport facilities. Power and telecommunication are provided via a combination of underground and overhead lines. Electrical circuits are on 3-phase power. Telecommunication lines are a combination of copper, coaxial, and fiber optic cables.

Sewer service to the airport is owned by the City of Dillingham. Electric, telecom and sanitary sewer services to the airport cross the runway immediately north of the apron. There are culverts under the runway and taxiway.

Relocation of three spans of overhead electric lines on poles along Kakanak Road (south of the Runway 1 end) to underground lines was performed with the Dillingham Airport Improvements project (Project No. 59304) in conjunction with RSA expansion and LOC/DME relocation. Utility relocation has already occurred along the curve on Wood River Road in anticipation of a future road realignment. More information is provided in the Utilities Inventory prepared for the Master Plan. A utility conflict report, utility agreements, and relocation design will be required for a future project that corrects the RSA.

#### 4.4.4 Airport Fence

Fencing surrounding several areas of the airport is difficult to access for repairs. Much of the land is wet, densely vegetated, and not suitable for breach identification and repair access by vehicle. A portion of the airport fence is situated at the bottom of the south RSA embankment slope, limiting access for maintenance, and causing the accumulation of snow from plowing operations. Snow drifts at multiple locations accumulate to the point where they overtop the fence. There is a project in the design phase for fence improvements and construction of a service road to bring the fence into compliance with 49 CFR § 1542.203.

#### 4.4.5 Land Use and ROW Considerations

DLG property is surrounded by residential development on all sides except the northeast. Much of the surrounding parcels are held as Alaska Native Allotments. Most residential development is centered around the major road corridors of Kakanak Road and Wood River Road. There are also homes and parcels along Waskey Road, which intersects the RW 19 approach. Two residences are adjacent to the airport property boundary to the northwest and are only accessible by Airport Road. There is a cluster of residences along the southeast edge of the runway. The Dillingham Airport Land Occupancy drawing identifies an encroachment east of the runway.

The Bureau of Indian Affairs (BIA) effectively controls the platting process for sub-dividing allotment properties for partial parcel acquisition. BIA control over this process can lower the likelihood of project success, increase project costs, and cause significant delays for partial property acquisition. For these reasons, full-parcel acquisition is recommended for required airport property acquisition of Native Allotments. For the purposes of this study, full acquisition of allotment properties is assumed to fully contain and protect the Runway Protection Zones (RPZs) and OFAs within airport property.

The ultimate decision to acquire full or partial parcels will be made closer to an RSA expansion project. The final determination should consider the necessity of the acquisition to protect the RPZs/OFAs/RW approaches, parcel ownership/allotment restricted status, likelihood of success, timeline, costs, existing site development, and BIA control over the subdividing/platting process. The acquisition of A&H easements should also be considered, especially where airspace obstructions are the only deficiency.

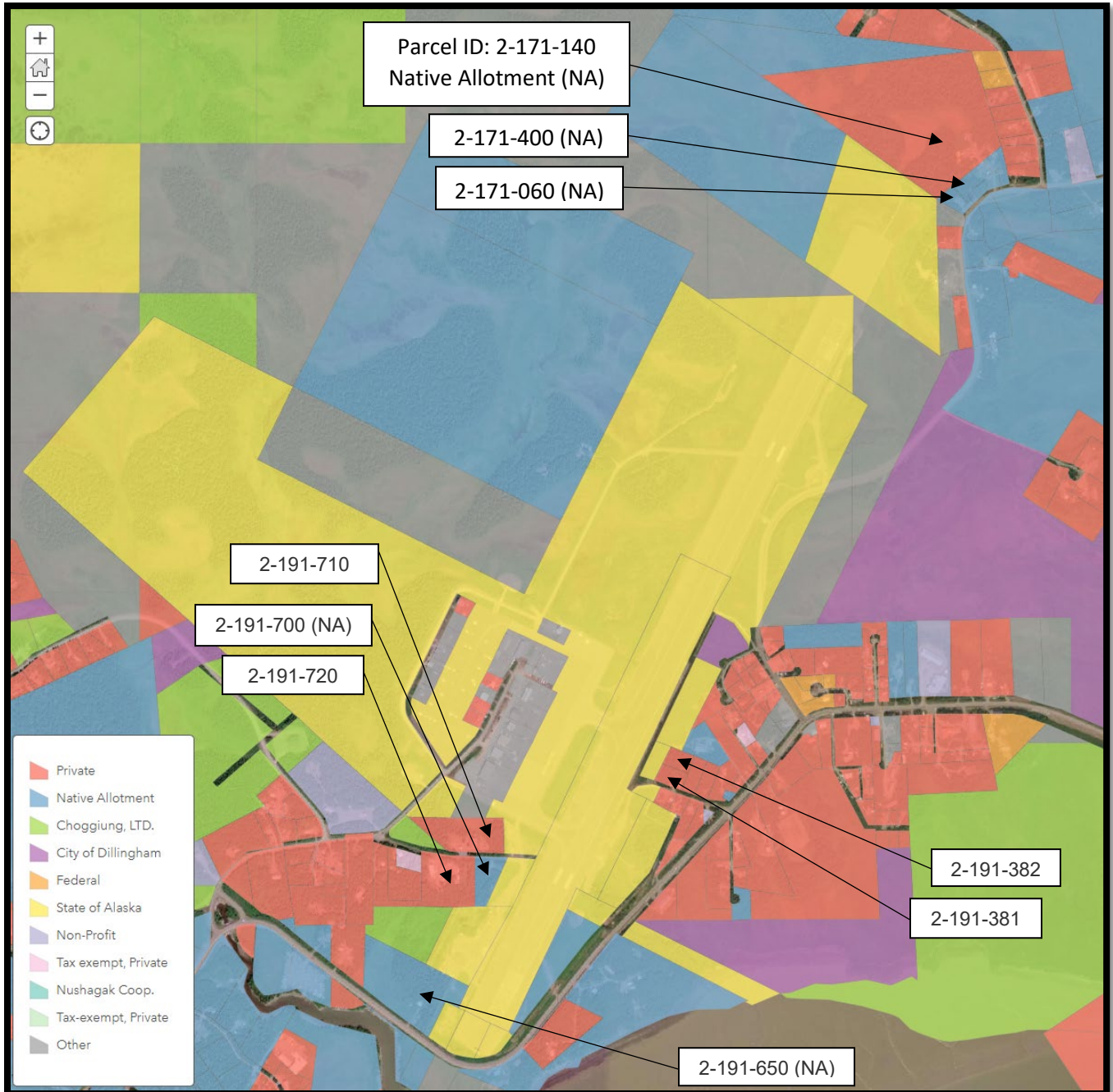

Figure 7: Land Ownership Map<sup>5</sup>

<sup>5</sup> City of Dillingham/Arc GIS, Parcels Online, <https://city-of-dillingham-dillingham.hub.arcgis.com/datasets/parcelsonline/>

#### 4.4.6 Airspace Obstructions

There are existing obstructions to the RW 19 approach. It is not practicable to clear all the identified existing and ultimate obstructions. Some obstructions are located on privately held land, including residential development and Alaska Native Allotments. A&H easements may be acquired for the topping or clearing of obstructing trees.

From AC 150/5300-13A *Airport Design*:

*“Land acquisition to protect all possible airspace intrusions is generally not feasible, and is usually supplemented by local zoning, easements, or other means to mitigate potential incompatible land uses and potential obstacle conflicts... At a minimum for new runways, land acquisition should include Object Free Areas (OFAs) and Runway Protection Zones (RPZs). To the extent practicable, land acquisition should include adequate areas surrounding the runway(s) to protect the runway approach and departure surfaces identified in paragraph 303, and for existing and planned runway OFAs and RPZs.”*

For the figures and cost estimates under this study, property would be acquired for RPZs and OFAs; obstructions would be cleared only within airport property.

#### 4.4.7 Wetlands and Environmental Background Information

There are United States Army Corps of Engineers mapped wetlands on and around airport property, most prevalently around the north end of the airport (Figure 8). Squaw Creek drains into the Nushagak River south of the airport.

An Environmental Assessment (EA) was prepared for the Dillingham Airport Improvements project, which widened and extended the RSA to its current configuration. This was “the maximum extent practicable” at the time of project. The EA resulted in a Finding of no Significant Impact (FONSI). The project was found to be in accordance with National Environmental Policy Act (NEPA) and approved by FAA in 2012. The State Historic Preservation Office (SHPO) concurred with a determination of no historic properties affected. Required permits pursuant to the Clean Water Act included: APDES Construction General Permit, Alaska Wastewater General Permit for any construction dewatering in the vicinity of contaminated sites, and a USACE wetlands permit.<sup>6</sup>

The 2012 Dillingham Airport Improvements project included 12.7 acres of unavoidable wetland impacts. Wetland avoidance and minimization measures for the project included: minimizing the wetland fill footprint by steepening side slopes to 2:1 in areas and stabilizing side slopes with native vegetation to prevent stormwater pollution. The proposed RSA widening alternatives would have similar environmental documentation and permit requirements. The magnitude of wetland impacts is similar between the previous RSA expansion and the proposed RSA widening.

The Alaska Department of Environmental Conservation (ADEC) Contaminated Sites Database shows three active contaminated sites on the DLG aprons, including one PFAS site.<sup>7</sup> The report of PFAS may complicate projects involving excavation and will require coordination with ADEC.

---

<sup>6</sup> Dillingham Airport Improvements (59304) Final Environmental Assessment, DOT&PF, May 2012

<sup>7</sup> Alaska DEC Contaminated Sites, Alaska Department of Environmental Contamination, <https://dec.alaska.gov/spar/csp/>.



Figure 8: Wetlands Map<sup>8</sup>

<sup>8</sup> US Fish and Wildlife Service National Wetland Inventory, <https://fwsprimary.wim.usgs.gov/wetlands/apps/wetlands-mapper/>

#### 4.4.8 Geology and Soil Conditions

The ground surrounding the runway to the northwest is comprised of compressible peat, underlain by silt. Geotechnical investigations were performed for RSA embankment expansion under the Dillingham Airport Improvements project. The following is summarized from the Geotechnical Report for the project: In upland areas in the airport vicinity, there is a thick layer of silt overlying sand or gravel deposits. The minimum depth to coarse-grained soils is 20 feet. The native soils in lowland terrain are generally poorly drained muskeg terrain underlain by peat deposits. Peat thickness north and west of RW 19 is as thick as 21.5 feet. The peat deposits are typically wet (saturated to ground surface), low density, and highly compressible. The underlying silt subgrade materials are highly frost susceptible, but no permafrost was encountered during drilling. Embankment materials are sand and gravel from local sources.<sup>9</sup>

Northwest RSA expansion under that project was composed of geotextile stabilization over undisturbed ground, borrow contained within a geogrid envelope, and crushed aggregate surface course (CASC). Surcharge and muck excavation were considered in the geotechnical recommendations. Muck excavation was cost prohibitive due to significant peat depths. A surcharge height was deemed to constitute an airspace obstruction to the runway. Consolidation was anticipated, with staged construction recommended. Primary consolidation was expected to occur during the first construction, while secondary, lesser consolidation was expected to continue through the life of the embankment.<sup>10</sup>

To date, the northwest RSA embankment is experiencing concerning levels of differential settlement and instability. A berm has emerged in the muskeg outside the embankment edge with surface irregularities and cracks exceeding a four-foot depth in certain areas.

### 4.5 Runway Line of Sight and Parallel Taxiway

#### 4.5.1 LOS Deficiency

In addition to the substandard RSA and OFA penetrations, the runway also has a significant line-of-sight (LOS) deficiency. The LOS deficiency is caused by long-term embankment settlement at the northeast end after the runway was lengthened back in the 1970s.<sup>11</sup> The elevations of both thresholds are below the elevation at the runway mid-point. The crest curve in the middle of the runway forms a hump that blocks the ability to view the other runway end when a plane is positioned at the opposite threshold.

For airports without a full-length parallel taxiway, AC 150/5300-13 *Airport Design* requires that “any point 5 feet (1.5 m) above the runway centerline must be mutually visible with any other point 5 feet (1.5 m) above the runway centerline.” In the existing runway profile configuration, the crest curve near the midpoint of the runway profile violates the five-foot LOS line by 7.2 feet. To fully correct the runway LOS, the RW 19 threshold would need to be raised by 15.7 feet. Elevating the RW 1 threshold is restricted due to maximized embankment slopes and the proximity to Kakanak Road. The elevation of the crest curve is limited from significant cut by the need to tie into TWs A and B and the apron at acceptable grades.

---

<sup>9</sup> Dillingham Airport Improvements (59304) Geotechnical Report, DOT&PF Central Region Materials, February 2012

<sup>10</sup> Dillingham Airport Improvements (59304) Geotechnical Recommendations, DOT&PF Central Region Materials, April 2012

<sup>11</sup> Dillingham Airport Improvements (9304) Runway Safety Area Practicability Study Memorandum, DOWL HKM, January 2011



#### 4.5.2 Parallel Taxiway

With the addition of a full-length parallel taxiway, the AC 150/5300-13A line-of-sight requirement is lessened to visibility between any two points on the runway separated by half the runway length. Adding a parallel taxiway would reduce RW 19's elevation raise requirement to 4.3 feet.

A full parallel taxiway would run the full length of the runway, intersecting the apron and connecting at both thresholds. Construction of a full-length parallel taxiway would require acquisition of private and Native Allotment land south of the apron for the taxiway, TOFA, and perimeter fencing south of the apron. Property acquisition may take 3 – 5 years or more. The costs for full parcel acquisition may range from \$300,000 - \$500,000, depending on the relative ease or contentiousness of acquisition for the individual parcels. Approximately three parcels would be impacted, including two private parcels (Parcel IDs 2-191-710 & 2-191-720) and one Native Allotment (2-191-700).

Regarding environmental impacts, constructing a parallel taxiway would place fill into 9 acres of wetlands.

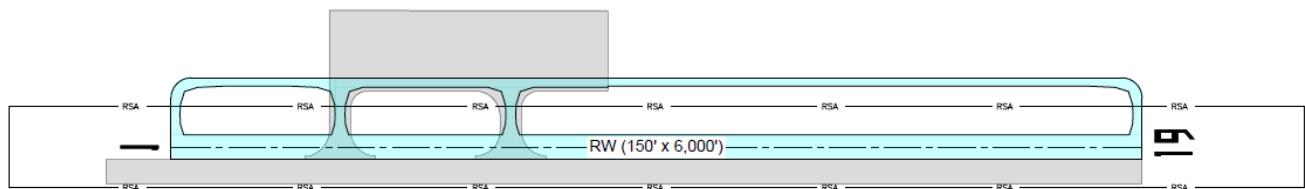

Figure 9: Full-Length Parallel Taxiway

A partial-length parallel taxiway would also provide safety mitigation and increased operational capacity by allowing aircraft to move off the runway more quickly. Property acquisition would not be required for a partial parallel taxiway that extends north from the apron to the RW 19 threshold; however, a partial parallel taxiway would not relax the LOS requirements.

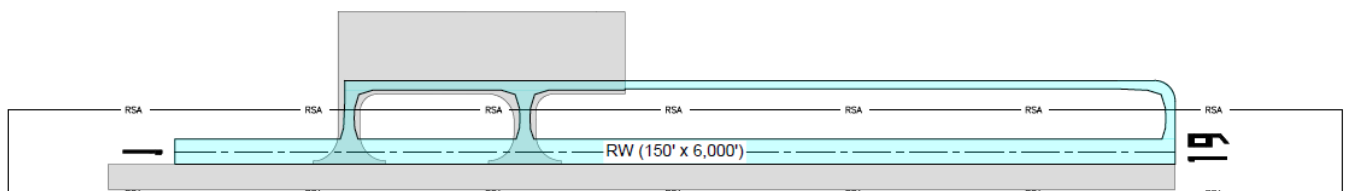

Figure 10: Partial-Length Parallel Taxiway

The parallel taxiway would be built to a 50-foot width in accordance with design standards for the Taxiway Design Group (TDG) 3 critical aircraft. DOT&PF Maintenance and Operation (M&O) personnel have expressed concerns about snow berms limiting usable taxiway width in the winter; however, FAA will only participate in funding new taxiways sized to the standard dimensions stated for the critical aircraft group. An additional benefit of the full parallel taxiway is that it could be used as a temporary runway during future runway projects, including projects to correct LOS; however, the narrow taxiway width will limit which aircraft are able to utilize it as a temporary runway.

#### 4.5.3 LOS Correction

The LOS deficiency may be resolved in one of two ways: by raising the RW 19 threshold with nearly 16 feet of fill or by placing approximately 4 feet of fill at the RW 19 threshold and constructing a full-length parallel taxiway. Full

LOS correction without a full-length taxiway is not possible over one construction season. It would have to be completed incrementally over several seasons or several projects. In contrast, once a full-length parallel taxiway is constructed, the RW 19 threshold elevation will only need to be raised by 4.3 feet which would still be challenging to construct all-at-once next to an open runway.

The existing runway profile and LOS correction scenarios are depicted in Figure 11. Cross sections are shown in Figure 12. The extent to which the proposed runway can be raised is limited by safety and airspace surfaces around the existing runway used in a temporary half-width configuration to maintain operations during construction. This limitation could be eliminated by constructing the full parallel taxiway for use as a temporary runway during runway LOS correction construction.

The estimated costs of full and partial taxiway construction and LOS correction are provided in Table 4. The threshold elevation could also be raised incrementally beginning with the runway shift, followed by adding materials during each successive pavement and rehabilitation project. It would take over ten years for the LOS to be resolved using the incremental method. The costs would be higher over time due to mobilization and administrative costs for each project.

Construction of a partial-length parallel taxiway for safety mitigation should be evaluated while property acquisition is being pursued for the construction of a full-length parallel taxiway.

**Table 4: LOS and Parallel TW Cost Estimates**

Option	LOS Resolved	RW Fill Material	ROW Needed	Added Cost
<b>LOS Correction w/o TW</b>	Yes	1,382,430 Tons	No	\$13.3 Million+
<b>Partial Parallel TW</b>	No	-	No	\$6.7 Million+
<b>Full Parallel TW</b>	LOS Correction w/ TW	-	Yes	\$9.1 Million+
<b>LOS Correction w/ TW</b>	w/ Full Parallel TW	293,420 Tons	No	\$2.1 Million+

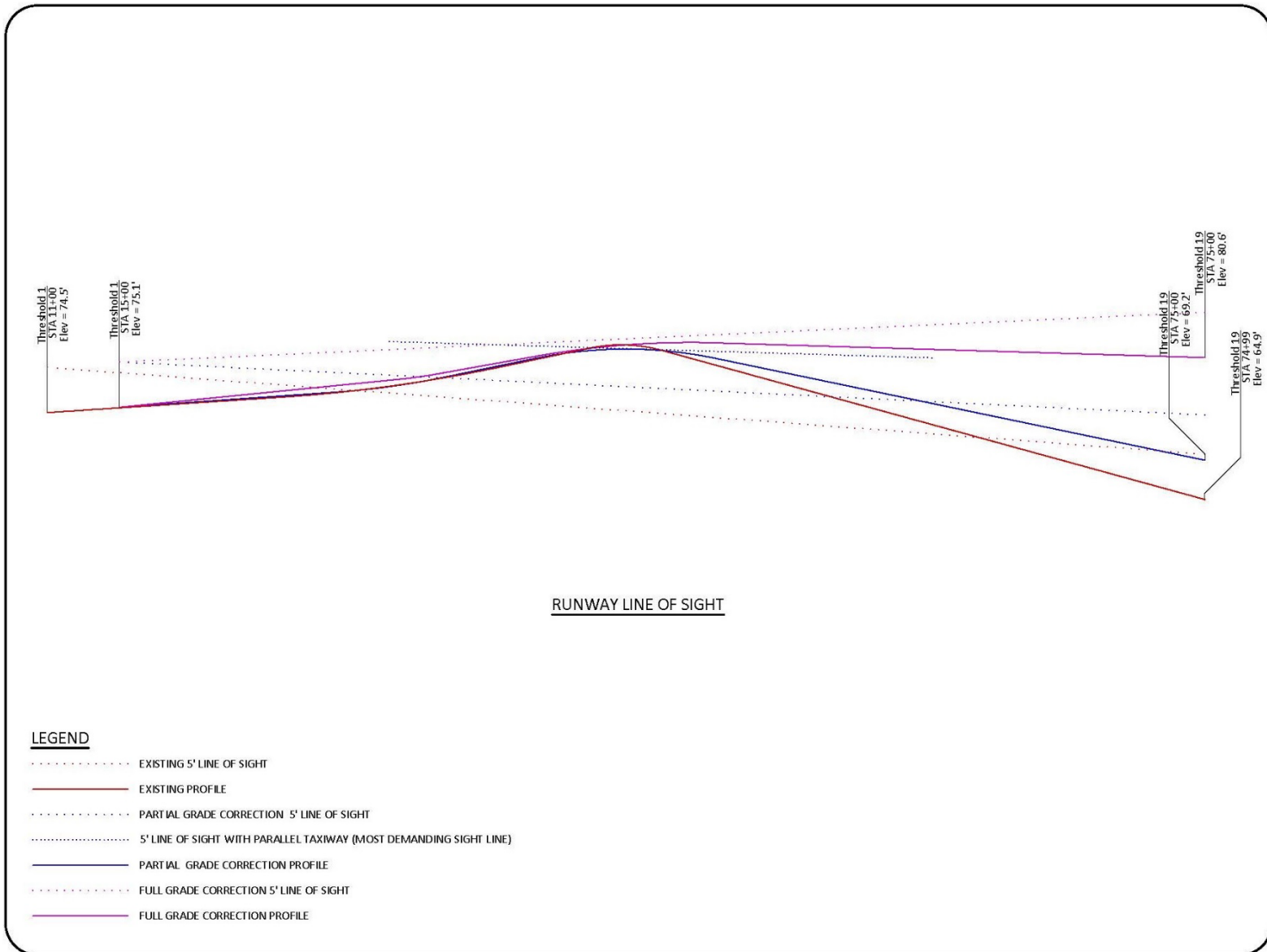

Figure 11: LOS Profiles

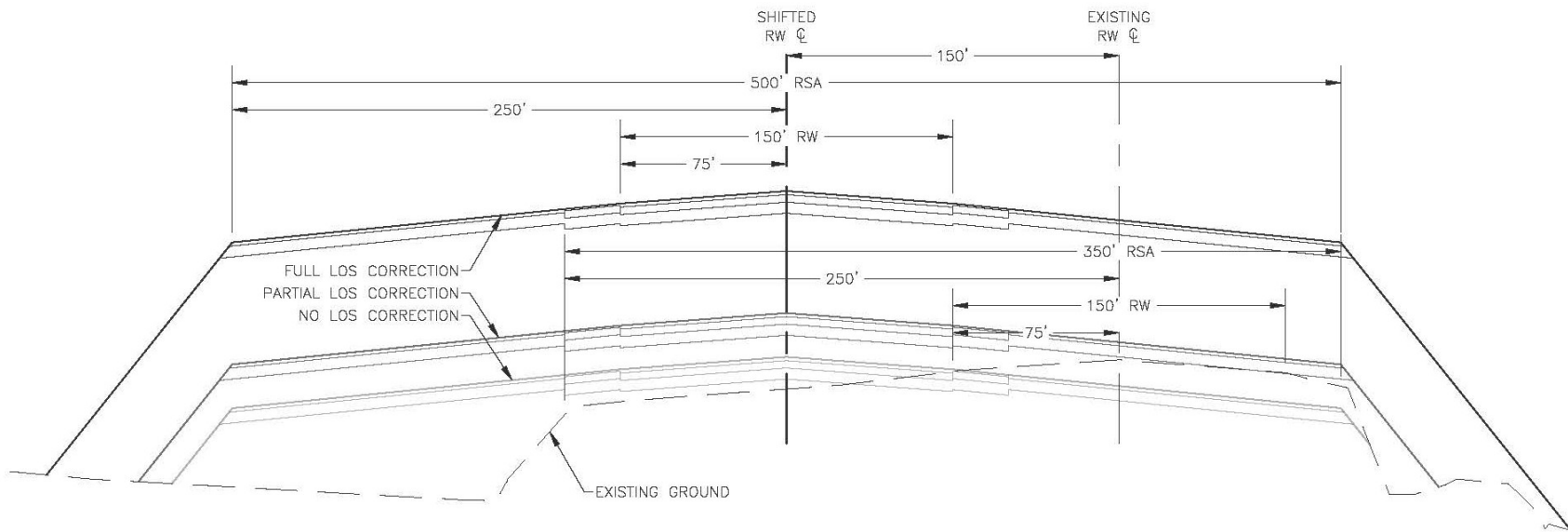

Figure 12: LOS Correction Sections

## 4.6 Visual and Navigation Aids, Approach Procedures, and Airport Lighting

### 4.6.1 Visual and Navigation Aids

There are visual and navigational aids (NAVAIDs) in place for DLG. NAVAIDs and equipment at the airport consist of: omni-directional approach lights (ODALs), rotating airport beacon, localizer, precision approach path indicator (PAPI), visual approach path indicator (VASI), wind cones/segmented circle, Stand Alone Weather Station (SAWS), and an automated weather observing system (AWOS). The AWOS is located immediately south of the Terminal Apron, outside the existing OFA. There is an FAA flight service station (FSS) located near TW C and north of the Terminal Apron.

The localizer is positioned at the end of the south RSA on a steel platform. Very high frequency omni-directional range (VOR), distance measuring equipment (DME), and non-directional beacon (NDB) facilities are located off site, approximately 3 miles south of the airport. The location of the other airport NAVAIDs is shown on the airport diagram below.

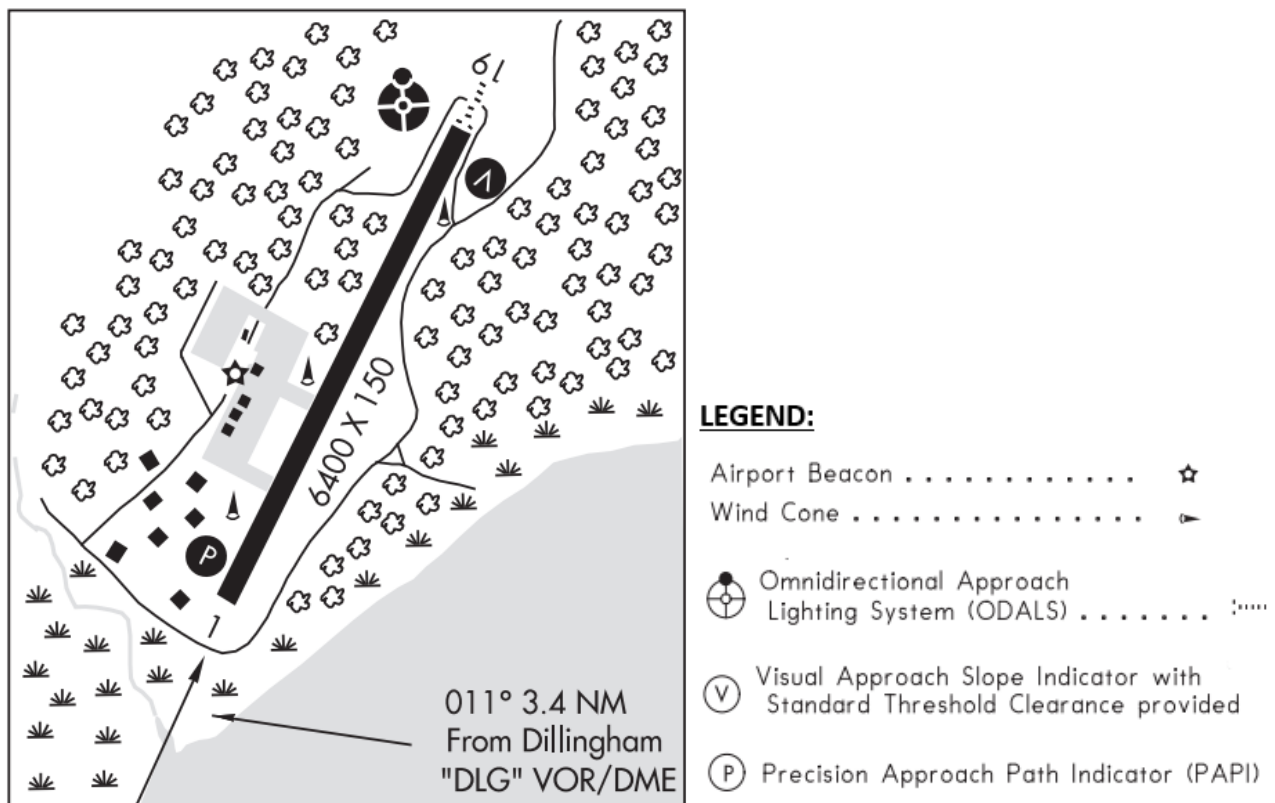

Figure 13: Airport Diagram with NAVAIDs<sup>12</sup>

### 4.6.2 Approach Procedures

The localizer allows for a non-precision instrument (NPI) approach to RW 19. The VOR enables a NPI approach to RW 1. There are also RNAV (GPS) approaches to both runway ends published in the Alaska volume of the FAA U.S. Terminal Procedures Publication. RW 1 is the primary runway direction used for airport approach and departure.

<sup>12</sup> FAA Chart Supplement Alaska, DLG, Effective 1/27/22 to 3/24/2022

### 4.6.3 Airport Lighting

The Dillingham Airport lighting system is comprised of high-intensity runway lighting and medium-intensity taxiway lighting. The airport lighting system is failing and should be replaced. All the lighting components have degraded including the regulator, connections, insulation, wiring, and transformers. The lighting system is approximately 16 years old. This is beyond the 10-year minimum useful life defined in Table 3-8 of FAA Order 5100.38D *Airport Improvement Program Handbook*, meaning it is eligible for replacement. Ohm resistance testing performed on the runway and taxiway lighting systems revealed values well below standards in Specification L-108, indicating degradation of the conductor insulation.

## 5.0 RSA Improvement Alternatives

This study has determined that it is practicable to shift the runway 150 feet west towards the apron and expand the RSA. FAA Order 5200.8 *Runway Safety Area Program* provides guidance in determining considered alternatives for the RSA to conform to AC 150/5300-13A standards:

*The first alternative to be considered in every case is constructing the traditional graded area surrounding the runway. Where it is not practicable to obtain the entire safety area in this manner, as much as possible should be obtained. Then, the following alternatives shall be addressed in the supporting documentation. The applicability of these alternatives will vary, depending on the location.*

- a. Relocation, shifting, or realignment of the runway*
- b. Reduction in runway length where the existing runway length exceeds that which is required for the existing or projected design aircraft*
- c. A combination of runway relocation, shifting, grading, realignment, or reduction*
- d. Declared distances*
- e. Engineered Materials Arresting Systems (EMAS)*

The following RSA alternatives would use a combination of methods and improvements as determined during the design of a future project to correct the RSA and other airport deficiencies. Each alternative sets the adjusted runway profile similar to existing elevations and assumes additional fill would be placed on the RW 19 end in a future project to address the LOS deficiency. Each alternative also assumes that Modifications of Standards (MOS) would be obtained as needed for LOS and OFA deficiencies not corrected by the RSA project. Line-of-sight resolution methodology should be considered based on the evaluation and cost estimates provided in section 4.5.

The following four alternatives were considered for their practicability:

- Alternative 1: Offset RW 150' west
- Alternative 2: Offset RW 150' west, shift RW 1 threshold 400' north
- Alternative 3: Expand existing RSA
- Alternative 4: No build, publish declared distances

## 5.1 Alternative 1: Offset RW 150' West

### 5.1.1 Description

This alternative consists of offsetting the runway 150 feet west of the current location. The new west runway edge will be at the current west edge of the RSA so the RSA will need to be widened 150 feet to the west to meet standards. The runway length would remain 6,400 feet, exceeding the required runway length for the critical aircraft. The safety area to the south would meet standards by the implementation of declared distances. The RW 19 Landing Distance Available (LDA) and Accelerate-Stop Distance Available (ASDA) would be decreased to 6,000 feet.

The alternative figure below shows the proposed runway relocation and RSA in relation to the existing airport. See Appendix A: Alternative Figures for more detail, including runway profiles and surrounding impacts.

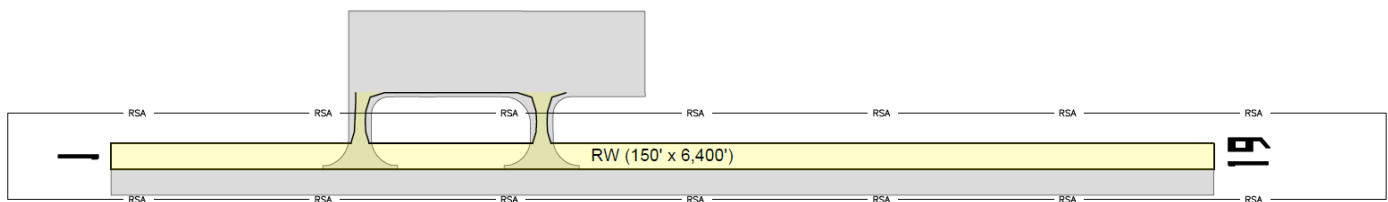

Figure 14: Alternative 1

### 5.1.2 Airport Impacts

Moving the runway would be a full reconstruction with complete runway demolition, a new structural section composed of subbase, stabilized base course, and asphalt pavement. Additional fill would be added during reconstruction to reduce the line-of-sight deficiency. The runway offset would shorten TW A and TW B to 400 feet. The taxiways would be reconstructed back to the apron to accommodate the runway shift. The taxiways would be updated to current FAA fillet geometry standards and their width would be reduced to 50 feet in accordance with TDG 3 standards.

Offsetting the runway would allow the existing RSA to be widened to the 500-foot standard by constructing an additional 150 feet of embankment to the west. RSA embankment expansion would not be required to the east. This would minimize disruption of existing infrastructure east of the runway.

This alternative proposes a 6,400-foot-long runway to match existing length. FAA will only participate in reconstructing a 6,000' runway due to the change in critical aircraft. As the airport sponsor, DOT&PF would be responsible for the costs of constructing a runway length exceeding an FAA approved runway length determination.

Implementing declared distances would provide the required 1,000-foot safety area beyond the RW 19 departure end with the existing 600-foot RSA embankment and 400 feet of remaining runway pavement beyond the RW 19 LDA and ASDA. This would allow the RSA to meet length standards without needing to relocate Kananak Road.

The runway does not currently have paved shoulders, but they are recommended for ADG III aircraft and would be added at a width of 25 feet.<sup>13</sup> No displaced thresholds, clearways, or stop ways are proposed. 200 x 200-foot blast pads would be reconstructed beyond the runway thresholds within the RSA length. Shoulders and blast pads would be constructed at a reduced pavement section, as they are not intended to be structural pavement. Runway pavement markings would be applied to the shifted runway, similar to existing dimensions.

Runway edge and threshold lighting, as well as connecting taxiway lighting would be replaced. The ODALS, PAPI/VASI, and localizer would be replaced in-line with the offset runway. FAA may elect to replace the ODALS with MALSR and not replace the PAPI/VASI, in accordance with current NAVAID standard installations. FAA electrical equipment enclosures, the primary wind cone and segmented circle, SAWS antenna, supplemental wind cone, and AWOS would be relocated, because they are within the shifted runway OFA. The two culverts crossing under the runway and RSA would be extended. The TW A and B cross culverts would be removed and relocated to near the toe of the proposed runway embankment.

#### 5.1.3 Roadway and Utility Impacts

Wood River Road would be realigned to outside the OFA. The overhead electric line along this portion of the road has already been relocated in advance of the road realignment. Buried telephone and fiber optic (FO) lines remain along the existing Wood River Road curve and would be relocated. The utilities are owned by Nushagak Electric and Telephone Cooperative. The FO line runs from their downtown Dillingham office to a hut on Waskey Road. FO will not allow for additional splices to be added. The FO relocation would need to tie into existing nodes outside airport property. There is fish processor at the end of Wood River Road operating during the summer months with substantial loads and will require coordination if utility services are interrupted.

Several underground utilities cross underneath the runway embankment near the midpoint, including telephone, FO, electric, and sanitary sewer lines. Airport base maps indicate there is an electrical vault and sanitary sewer manhole within the existing west RSA, but their existence has not been field verified. These surface structures would need to be relocated, because they conflict with the proposed runway location.

#### 5.1.4 Cemetery Impacts

The Evergreen Cemetery is located within airport fee property and an easement. The cemetery is an OFA penetration. Based on USGS LIDAR data, the cemetery and fence would remain an OFA penetration with the 150-foot west runway shift, but to a lesser extent than in the existing configuration.

The study recommends the cemetery be closed to new burials within 100 feet of the existing fence line paralleling the runway except for prearranged interments such as immediate family members. Previous mitigation measures surrounding the cemetery included fencing and tree clearing. Continued tree clearing is recommended to reduce OFA penetrations. MOS would need to be applied for the cemetery remaining an OFA penetration as required under FAA Order 5300.1G.

#### 5.1.5 ROW, Obstruction, and LOS Impacts

Right-of-way acquisition for this alternative would impact four Native Allotment parcels. Acquisition is required to fully contain the RPZs and OFA within airport property. Full acquisition of allotment parcels is assumed.

Airport property does not encompass the entirety of the existing north RPZ. The RPZ footprint would shift with the runway. Property acquisition is required to fully contain the north RPZ. Approximately 7.25 acres of the RPZ would

---

<sup>13</sup> FAA AC 150.5300-13A Airport Design, Section 304c & Table 3-5



be outside airport property and within Parcel IDs 2-171-140 and 2-171-060. A review of the record's office records revealed both parcels are likely in restricted allotment status. The total acreage of these two Parcels is 35 acres.

With the runway shift, the OFA extends 35 feet outside airport property on the west side, south of the apron. Two allotment parcels (Parcel IDs 2-191-700 and 2-191-650) would be acquired. For full parcel take, approximately 12 acres would be acquired to contain the shifted OFA. The airport perimeter fence should be relocated to encompass the OFA and newly acquired property. Property acquisition would allow for a full parallel taxiway to mitigate the LOS deficiency.

Trees penetrate the existing RW 19 Part 77 approach surface by 23 feet. With the runway shift under this alternative, these penetrations would remain at 23 feet. There are existing terrain penetrations along most of the existing runway OFA. This alternative would level the proposed OFA based on the shifted runway location and elevation.

OFA and airspace obstructions would be reduced by raising the RW 19 threshold elevation associated with the LOS improvements. The LOS correction with parallel taxiway option introduced in Section 4.5 would reduce RW 19 Part 77 approach surface tree penetrations to 19 feet. The RW 19 raise associated with the LOS correction without a parallel taxiway added would further reduce these penetrations to 7 feet.

Following the RPZ parcel acquisition, runway airspace obstructions could be cleared. Tree cleaning (and minor terrain leveling) would occur to clear obstructions to RW 19 Part 77 approach and transitional surfaces and the departure surface within the expanded airport property. Based on available data, additional obstructions would remain outside the acquired parcel limits. It is not considered feasible to acquire property and clear all obstructions within the runway approach and departure surfaces.

Identified obstructions are shown on the alternative figures in Appendix A, identified by obstruction type (trees vs terrain) and which surface they penetrate.

#### 5.1.6 Environmental Impacts and Geology

The primary environmental impact for RSA expansion is placement of fill into wetlands. There are existing wetlands west of the runway (Figure 4). Fill for expanding the RSA into this area would impact wetlands. Approximately 14 acres of wetland impacts are estimated for the safety area embankment expansion.

RSA expansion into the northwest wetland areas would require stabilization techniques to combat settlement, such as over-excavation, allowing for embankment consolidation, and the placement of geotextiles, among other methods.

### 5.1.7 Costs

The cost for this alternative broken out by element is shown in the table below. Estimate justification is contained within Appendix B.

**Table 5: Alternative 1 Cost Estimate**

Phase	Phase Estimate
<b>Design</b>	\$4,800,571
<b>ROW</b>	\$5,804,000
<b>Obstruction Removal &amp; Clearing</b>	\$950,000
<b>Utilities</b>	\$1,525,000
<b>RW &amp; RSA Construction</b>	\$36,523,077
<b>Airport Lighting</b>	\$1,421,940
<b>Approach Lights &amp; Nav aids</b>	\$1,278,690
<b>Road Realignment</b>	\$503,000
Total Estimate:	<b>\$52,806,278</b>

## 5.2 Alternative 2: Offset RW 150' West, Shift RW 1 Threshold 400' North

### 5.2.1 Description

Like Alternative 1, this alternative achieves RSA width through offsetting the runway and expanding the RSA embankment width 150 to the west. In addition, the RW 1 threshold would be shifted 400 feet north along this new runway centerline, resulting in a runway length of 6,000 feet.

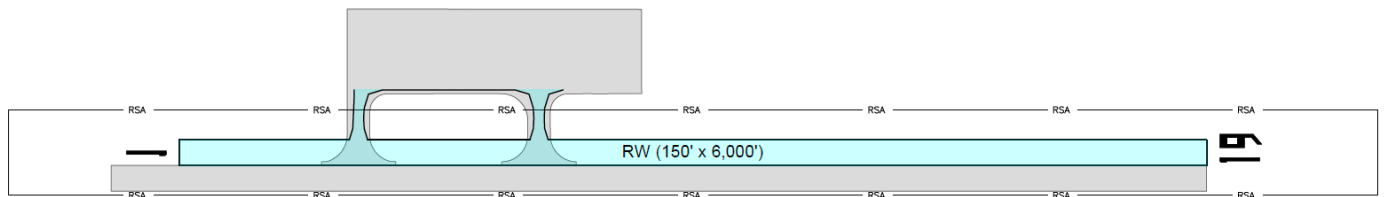

**Figure 15: Alternative 2**

### 5.2.2 Airport Impacts

This alternative has similar impacts to Alternative 1 but achieves the required RSA length by a shortening the runway through a northern RW 1 threshold shift and without implementing declared distances. Offsetting the runway and shifting the RW 1 threshold would provide the 500-foot RSA width and 1,000-foot RSA length beyond the threshold.

Complete runway and taxiway demolition and reconstruction would be required with new airport lighting, markings, approach lighting, visual aid and NAV AID (ODALs, PAPI/VASI, wind cones and segmented circle, SAWS antenna, AWOS) relocation. TW A and B length would be decreased to 400 feet long and 50 feet wide with fillet geometry. Paved runway shoulders and blast pads at both ends would be provided. Extension of the runway cross culverts would be required.

### 5.2.3 Roadway and Utility Impacts

Impacts to Kananak Road are avoided through the northern RW 1 threshold shift. Wood River Road would be relocated to outside the ROFA. Telephone and FO lines along Wood River Road would also be relocated. Utility surface structures for lines crossing under the airport that conflict with the proposed runway location would be relocated.

### 5.2.4 Cemetery Impacts

No RSA embankment construction is proposed towards the Evergreen Cemetery. The proposed runway offset moves the OFA away from the cemetery, but it would remain an OFA penetration. Like Alternative 1, the cemetery is recommended to be closed to most new burials within 100 feet of the existing fence line parallel to the runway and an MOS obtained for the remaining OFA violation.

### 5.2.5 ROW, Obstruction, and LOS Impacts

This alternative would require the same ROW acquisition as Alternative 1. Airport property would need to be obtained for the RW 19 RPZ and west runway OFA. The acquisition of four Native Allotment parcels is required. Total ROW acquisition is estimated at 47 acres. Property acquisition would allow for a full parallel taxiway to mitigate the LOS deficiency.

RW 19 airspace obstructions are the same under this alternative as Alternative 1. Tree obstructions within the proposed RPZ would be cleared once property is acquired. Terrain leveling would be required within the OFA to eliminate penetrations.

### 5.2.6 Environmental Impacts and Geology

This alternative would also fill 14 acres into the northwest wetland areas for RSA expansion. RSA expansion into the peat area would require stabilization techniques to combat settlement.

### 5.2.7 Cost

The cost for this alternative broken out by element is shown in the table below. Estimate justification is contained within Appendix B.

**Table 6: Alternative 2 Cost Estimate**

Phase	Phase Estimate
<b>Design</b>	\$4,743,813
<b>ROW</b>	\$5,804,000
<b>Obstruction Removal &amp; Clearing</b>	\$1,116,000
<b>Utilities</b>	\$1,525,000
<b>RW &amp; RSA Construction</b>	\$35,789,501
<b>Airport Lighting</b>	\$1,421,940
<b>Approach Lights &amp; Nav aids</b>	\$1,278,690
<b>Road Realignment</b>	\$503,000
Total Estimate:	<b>\$52,181,944</b>

### 5.3 Alternative 3: Expand Existing RSA

#### 5.3.1 Description

This alternative consists of expanding the RSA embankment around the existing runway.

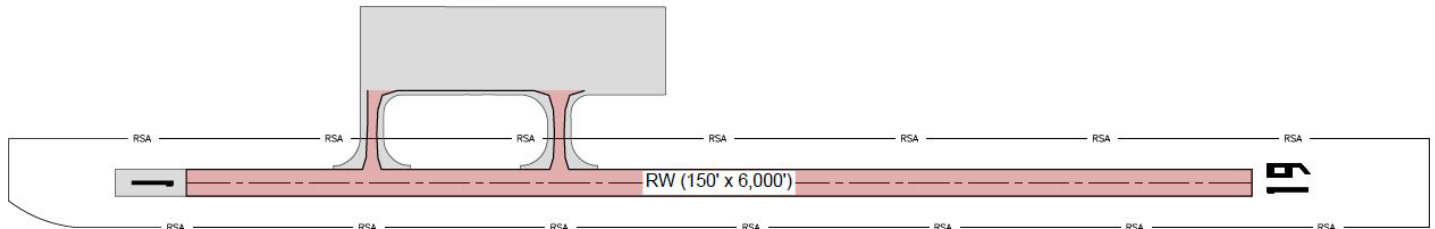

Figure 16: Alternative 3

#### 5.3.2 Airport Impacts

The RW 1 threshold would be shifted 400 feet to reduce the runway length to 6,000 feet and achieve 1,000-foot RSA length to the south. The east RSA width would be expanded to obtain a total RSA width of 500 feet, centered around the current runway.

The runway would be shortened by removing and re-marking pavement. Existing pavement may remain south of the relocated RW 1 threshold for use as the blast pad. There is not an immediate need to reconstruct the runway if it is not relocated. The taxiways may also remain unaltered. Without a runway reconstruction, there is no opportunity to adjust the runway profile elevations to improve LOS. The airport lighting system is failing and should be replaced. Most visual aids and NAVAIDs can remain in place. The SAWS antenna, wind cones and segmented circle would be relocated to outside the runway OFA. The RW 1 PAPI would be relocated with the shifted threshold. Runway cross culverts would be extended under the new RSA embankment to the east.

#### 5.3.3 Roadway and Utility Impacts

The proposed RSA would be chamfered at the south end to avoid impacts to Kananak Road. The RW 19 threshold shift and the chamfered RSA widening would make incremental improvements to RSA but would require an MOS for the RSA slightly below standards. Unlike Alternatives 1 and 2, the runway would not be offset from Wood River Road. The road would penetrate the runway OFA, to a greater extent than the other alternatives. Wood River Road and associated utilities would be relocated to outside the OFA.

#### 5.3.4 Cemetery Impacts

Expansion of the RSA embankment fill to the east would cover a portion of the cemetery. A portion of the burial sites would have to be exhumed and relocated under this alternative. This is likely not feasible.

#### 5.3.5 ROW, Obstruction, and LOS Impacts

Right-of-way acquisition for this alternative will impact approximately five parcels, including two private parcels and three Native Allotments. The entirety of the RW 19 RPZ is not within airport property at the current runway alignment. Acquisition for the RW 19 RPZ would impact one additional allotment (Parcel ID 2-171-400) beyond Alternatives 1 and 2. Acquisition of two private parcels (Parcel IDs 2-191-381 & 2-191-382), situated to the east of the runway, would be required to fully contain the OFA around the existing runway. The OFA property acquisition west of the runway under Alternatives 1 and 2 is not needed under this alternative. 36 acres of property acquisition

would be required. Property acquisition under alternative would not allow for a full parallel taxiway. LOS mitigation options would be extremely limited.

The current runway location has airspace (RW 19 Part 77 and departure surface tree penetrations up to 30 feet) and OFA penetrations. These would be cleared within the property to be acquired.

### 5.3.6 Environmental Impacts and Geology

This alternative would expand the RSA to east rather than the west. There are wetlands to the east of the current runway embankment as shown in Figure 4. This alternative would place fill into five acres into wetlands.

The existing ground conditions are generally more stable and less susceptible to settlement east of the current runway. The runway would not be relocated so as to make the best use of recently constructed RSA embankment like it would under the previous alternatives.

### 5.3.7 Cost

The cost for this alternative broken out by element is shown in the table below. Estimate justification is contained within Appendix B.

**Table 7: Alternative 3 Cost Estimate**

Phase	Phase Estimate
<b>Design</b>	\$2,610,677
<b>ROW</b>	\$4,560,000
<b>Obstruction Removal &amp; Clearing</b>	\$938,000
<b>Utilities</b>	\$1,366,000
<b>RW &amp; RSA Construction</b>	\$17,030,250
<b>Airport Lighting</b>	\$1,395,300
<b>Approach Lights &amp; Nav aids</b>	\$314,220
<b>Road Realignment</b>	\$503,000
Total Estimate:	<b>\$28,717,447</b>

## 5.4 Alternative 4: No Build, Publish Declared Distances

### 5.4.1 Description

This alternative would provide no constructed improvements to the existing conditions of the airport. The RSA embankment width would remain below FAA AC 150/5300-13A *Airport Design* standards at 350 feet and not centered around the runway. Declared distances may be published to improve the south RSA length beyond the RW 19 departure end to meet standards.

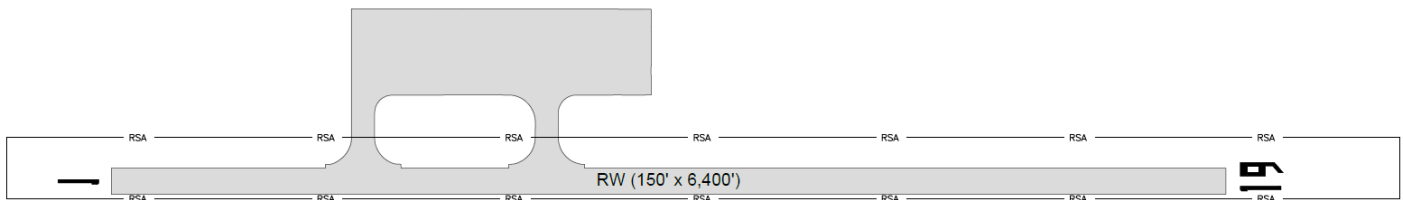

Figure 17: Alternative 4

### 5.4.2 Impacts

The RW 19 LDA and ASDA may be reduced by 400 feet to provide 1,000 feet of safety area to the south; however, this would reduce the usable portion of RW 19. All other declared distances remain at 6,400 feet. Because the RSA is not being physically improved and the runway is not being reconstructed, the runway is not required to be shortened.

Substandard RSA width and all other existing deficiencies would remain. Evergreen Cemetery and Wood River Road would remain as OFA penetrations. Departure and Part 77 approach surface tree penetrations would remain. Airport property would not fully encompass the north RPZ or east OFA. No property would be acquired. This alternative would not allow for a full parallel taxiway. LOS mitigation options would be extremely limited.

This alternative would make incremental improvements to the RSA by implementing declared distances but would not improve the RSA width or address other deficiencies.

## 6.0 Alternatives Considered and Deemed Not Feasible

Other alternatives considered under this study but determined not feasible include:

### 6.1 EMAS

An Engineered Materials Arresting System (EMAS) can be installed to stop errant aircraft when there is insufficient safety area beyond the runway end available. Runway Safe is the sole manufacturer of EMAS products that meet the FAA requirements of AC 150-5220-22B *Engineered Materials Arresting Systems for Aircraft Overruns*.

These systems have ongoing maintenance and replacement costs and require specialized equipment to clear snow. The crushable panels must be repaired or replaced when damaged by aircraft, vehicles, or wildlife. The premanufactured EMAS panels must be shipped to Dillingham, adding costs over local materials for the other alternatives. The Dillingham barge landing facility is a tidal harbor and only for seasonal use, complicating any panel replacement needed over the winter months. The EMAS installation has strict foundation stability requirements and will require deep site preparation to mitigate the differential settlement experienced at DLG.

According to FAA Order 5200.8 *Runway Safety Area Program*, EMAS is the last alternative consideration for addressing RSA deficiencies. It should only be considered and implemented when there are no feasible alternatives. Due to availability of the other presented alternatives to address the south deficient safety area length (such as reduced runway length and declared distances), an EMAS was deemed not feasible.

### 6.2 Runway Rotation

While a northwestern runway rotation would shift the runway partially away from Evergreen Cemetery and other RSA and OFA constraints to the east of the runway, it would shift the RW 19 approach further into the hillside and increase obstructions. This option would violate Federal Regulation Title 14 Part 77 *Safe, Efficient Use, and Preservation of Navigable Airspace*. It would also increase the need for the acquisition of allotment properties and decrease wind coverage of the runway.

### 6.3 Airport Relocation

A complete airport relocation would be more cost prohibitive than any of the presented alternatives and cause the most environmental impacts. The other alternatives maintain the current apron, taxiways, embankment, access road, and facilities, which would have to be reconstructed if the airport is relocated. Dillingham is not on the road system, and there is limited buildable land available for an airport relocation. Full private parcels, including Native Allotments, would need to be acquired to construct a new airport and access road. Construction would also take many years due to soil conditions and embankment consolidation needs.

## 7.0 Preferred Alternative

A matrix comparing the alternatives and impacts is presented in Table 8. Alternatives 1 and 2 have a similar disposition, impacts, and costs. They differ in the proposed runway length. Based on the runway length determined from the current fleet mix, only a 6,000-foot runway is required and fundable under the FAA Airport Improvement Program. Alternative 1 only achieves the south RSA length through declared distances, which is inferior to the RW 1 threshold shift and runway shortening under Alternative 2.

Alternative 3 maintains the runway in the current location and expands the RSA to the east to meet width standards. The eastward RSA embankment expansion increases impacts and proximity to surrounding community infrastructure. The increased proximity to site constraints limits any future airport expansion. Leaving the runway in place does not provide an opportunity to correct the LOS deficiency. This alternative requires relocation of the cemetery, which would be highly contentious and is not considered feasible.

Alternative 4, the no-build alternative, does not make significant improvements to the deficient RSA. RSA length could be achieved by implementing declared distances, but the RSA width would remain significantly undersized and not symmetric around the runway.

Alternative 2 is the preferred alternative because it obtains standard RSA dimensions, is in conformance with the runway length determination, and limits impacts to surrounding infrastructure.



**Table 8: Alternatives Matrix**

Component	Alternative 1	Alternative 2	Alternative 3	Alternative 4
<b>Basic Description</b>	Offset RW 150' West	Offset RW 150' West, Shift RW 1 Threshold 400' North	Expand Existing RSA	No Build
<b>RW Length</b>	6,400'	6,000'	6,000'	6,400'
<b>RW &amp; RSA Construction</b>	RW offset 150' west, RSA widened westward to meet 500' standard width. TW A & B shortened to 400'. Declared distances shorten LDA and ASDA to 6,000'	RW offset 150' west, RSA widened westward to meet 500' standard width. TW A & B shortened to 400'. RW 1 threshold shifted 400' north to create 1,000' RSA length to the south	Build RSA around existing RW; RW 1 threshold shifted 400' north to create 1,000' RSA length to the south; Extend RSA east to meet 500' standard width	None. Declared distances shorten LDA and ASDA to 6,000'
<b>RSA Meets Standards?</b>	Yes	Yes	RSA chamfered to avoid impacts to Kananak Rd	No
<b>Re-Align Wood River Road</b>	Yes, due to minor OFA penetration after RW offset	Yes, due to minor OFA penetration after RW offset	Yes, relocated. Greater OFA penetration without RW offset	No, remains OFA penetration
<b>Re-Align Kananak Road</b>	No	No	RSA chamfered to avoid impacts	No
<b>Utility Impacts</b>	Relocate telecom & FO lines along Wood River Rd. Relocate electrical vault and SS manholes for lines crossing under the RW.	Relocate telecom & FO lines along Wood River Rd. Relocate electrical vault and SS manholes for lines crossing under the RW.	Relocate telecom & FO lines along Wood River Rd. No impacts to utilities crossing under the RW midpoint.	None
<b>Airport Lighting</b>	Runway edge, threshold, and connecting TW lighting replaced	Runway edge, threshold, and connecting TW lighting replaced	Existing lighting system replaced in kind due to failure, age	Lighting system should be replaced under separate project
<b>Nav aids</b>	ODALs, PAPI/VASI, localizer, and wind cone & segmented circle replaced	ODALs, PAPI/VASI, localizer, and wind cone & segmented circle replaced	Wind cone and segmented circle relocated outside RW OFA (existing deficiency).	No impacts
<b>Evergreen Cemetery Disposition</b>	Remains an OFA penetration; close to new burials, clear trees	Remains an OFA penetration; close to new burials, clear trees	Within the expanded RSA, relocate	No change, remains OFA penetration
<b>Obstruction Clearing</b>	Part 77 and departure surface tree obstructions to the north. OFA terrain leveling.	Part 77 and departure surface tree obstructions to the north. OFA terrain leveling.	Part 77 and departure surface tree obstructions to the north. OFA terrain leveling (existing deficiencies).	Existing obstructions remain
<b>Property Acquisition</b>	For OFA to the southwest; north RPZ	For OFA to the southwest; north RPZ	For OFA to the east; north RPZ	None

## 8.0 Constructability and Schedule

The preferred RSA alternative should also consider the compatibility of correcting other deficiencies at the airport. Other than the RSA size, the other primary deficiency at DLG is the runway LOS as discussed in Section 4.5. The LOS correction scenario with the construction of a parallel taxiway is the most cost-effective and useful solution to bring the runway into LOS compliance. Combined with Alternative 2, the total cost of RSA and LOS correction would be \$63.5 million.

**Table 9: RSA & LOS Combined Costs**

Element	Estimate
Alternative 2 (Preferred Alternative):	\$52,181,944
Full Parallel TW:	\$9,178,290
LOS Correction w/ TW:	\$2,168,210
<b>Total Estimate:</b>	<b>\$63,528,444</b>

It is not feasible to close the airport during construction because of essential medevac service and economic impacts from the fishing industry. Corrections to the runway LOS for the shifted runway are limited by the need to maintain safe, temporary operations on the current runway during construction. The embankment raise required to correct the runway LOS would constitute an airspace (Part 77 primary and transitional surfaces) and safety surface (OFA, Obstacle Free Zone) obstruction to the current runway. These surfaces do not allow elevations or positive slopes extending above the elevation of the in-use runway. The dimensions of these surfaces would have to be reduced temporarily during construction to the extent safe for the operating aircraft. The amount the runway can be raised concurrently with an RSA expansion and runway shift project should be vetted through the development of the project's Construction Safety and Phasing Plan. The figure below shows half-width phasing for a runway elevation raise scenario.

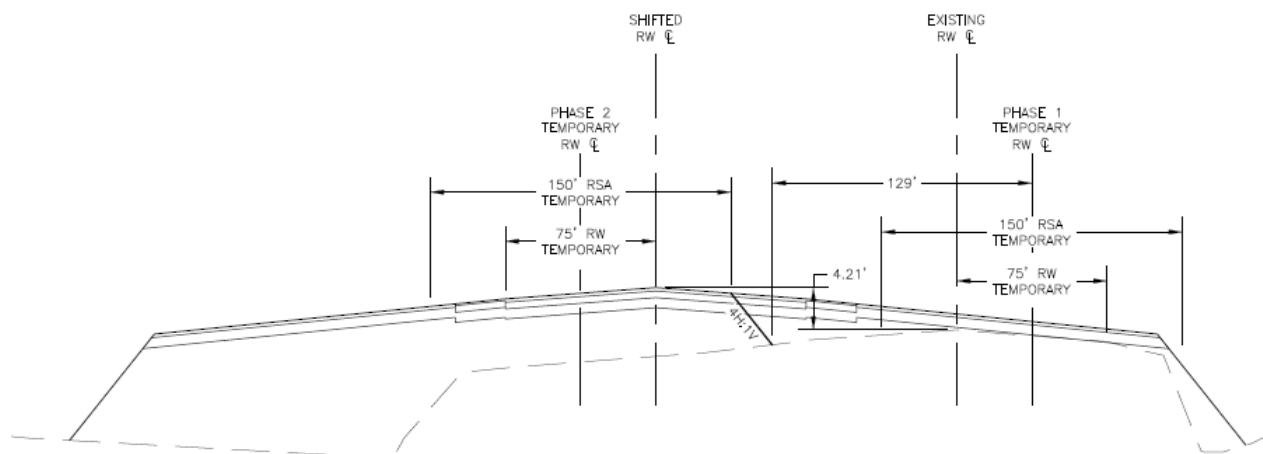

*Figure 18: Half-Width Phasing for RW Raise*

It is not anticipated that the LOS can be safely corrected under the same project that will improve the RSA and shift the runway. Instead, it is recommended to first construct the RSA improvements, followed by a parallel taxiway for use as a temporary runway during construction of the LOS improvements. Property acquisitions are required for the full parallel taxiway and estimated to take up to 5 years or more. The partial parallel taxiway should be constructed while property acquisitions are pursued for the south leg of the full parallel taxiway.

It is also recommended that the RSA improvements be constructed as a two-phase project. The RSA embankment fill should be expanded to required dimensions. Due to continued settlement concerns, further geotechnical investigations and recommendations should be performed. The newly expanded, full RSA should be allowed to consolidate prior to construction of the runway shift. The RSA improvement and runway shift also requires acquisition of allotment properties to fully contain the RPZ and shifted OFA. MOS's would be required for the project for remaining LOS and property deficiencies, with the understanding they would be corrected under the subsequent projects.

# APPENDIX A

Alternative Figures

Date Revised: 3/15/2022, 10:31 AM  
 Layout Name: ALL\_OVM 1  
 File Path and Name: Z:\project\2820.01 DOT\_C DIG AMP Update\Civil\ACAD\Alternatives\Alt\_Overview\03053-DIG\_Design\Alt\_Overview\_edit.dwg  
 Designed By: MM  
 Drawn By: AWA/RLC  
 Checked By: CJB

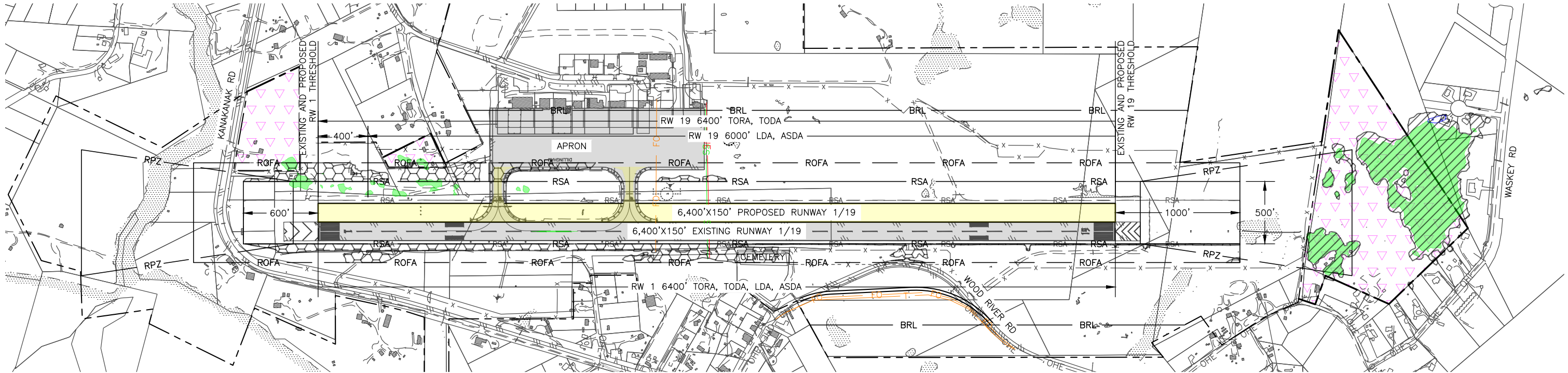

**ALTERNATIVE 1 – OFFSET RW 150' WEST**  
NTS

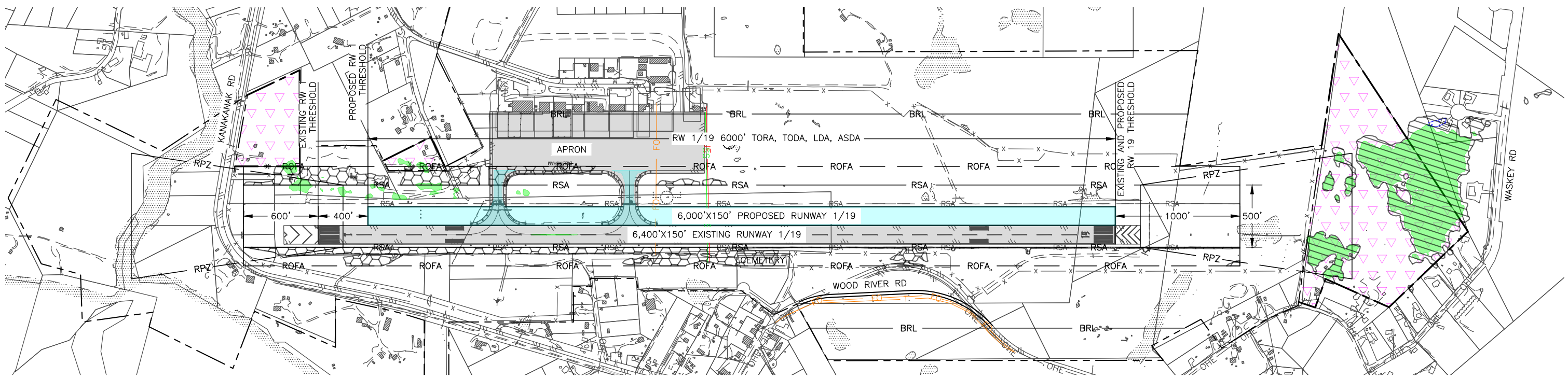

**ALTERNATIVE 2 – OFFSET RW 150' WEST, SHIFT RW 1 THRESHOLD 400' NORTH**  
NTS

- LEGEND:**
- PART 77 OBSTRUCTIONS
  - DEPARTURE SURFACE TERRAIN OBSTRUCTION
  - DEPARTURE SURFACE TREE OBSTRUCTIONS
  - OFA PENETRATIONS
  - EXISTING AIRPORT PROPERTY
  - ULTIMATE AIRPORT PROPERTY (FEE/A&H EASEMENT)
  - ▽ PROPERTY ACQUISITION

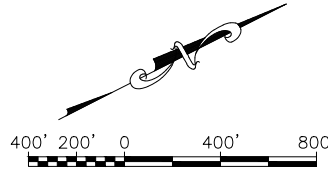

<b>PLANS DEVELOPED BY:</b> <b>R&amp;M CONSULTANTS, INC.</b> <b>9101 VANGUARD DR.</b> <b>ANCHORAGE, AK 99507</b> <b>(907) 522-1707</b> <b>CERT. OF AUTH. NO. AECC111</b>			BY	DATE	REVISION

**STATE OF ALASKA**  
**DEPARTMENT OF TRANSPORTATION**  
**AND PUBLIC FACILITIES**  
 4111 AVIATION AVE., ANCHORAGE ALASKA 99502  
 PHONE (907) 269-0590

**DILLINGHAM AIRPORT**  
 DILLINGHAM, ALASKA  
 AIRPORT MASTER PLAN  
 PROJECT No. CFAPT00353  
 AIP No. 3-02-0078-017-2018  
 ALTERNATIVE OVERVIEW

DATE:  
 3/15/2022  
 SHEET:  
 1 OF 2

Date Revised: 3/15/2022, 10:31 AM  
 Layout Name: ALL\_OVW\_2  
 File Path and Name: Z:\Project\2820.01 DOT\_C DIG AMP Update\Civil\ACAD\Alternatives\Alt\_Overview\030353-DIG\_Design\Alt\_Overview\_edit.dwg  
 Designed By: MM  
 Drawn By: AWA/RLC  
 Checked By: CJB

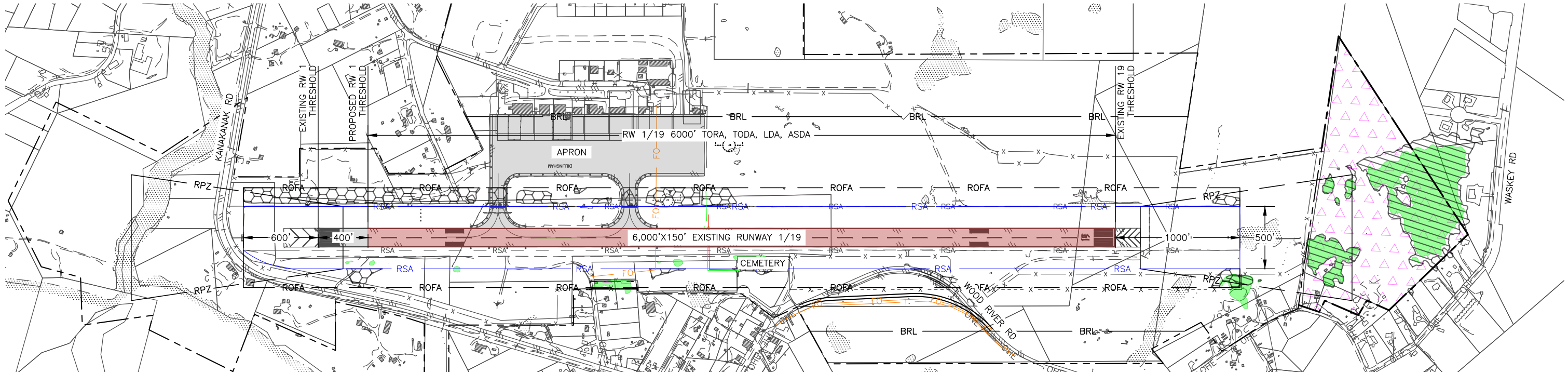

**ALTERNATIVE 3 – EXPAND EXISTING RW RSA, SHIFT RW 1 THRESHOLD 400' NORTH**  
NTS

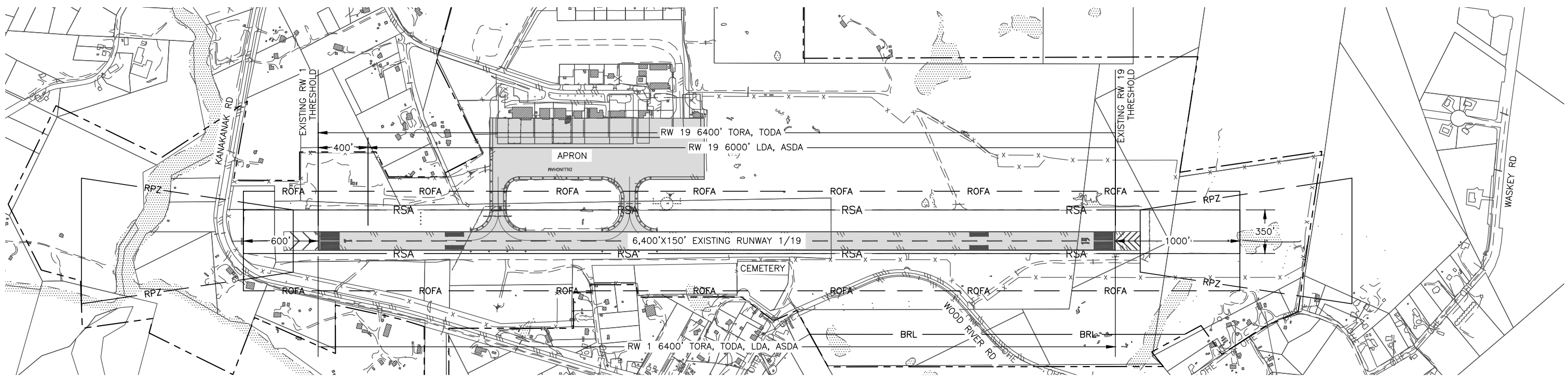

**ALTERNATIVE 4 – NO BUILD, PUBLISH DECLARED DISTANCES**  
NTS

- LEGEND:**
- PART 77 OBSTRUCTIONS
  - PROPERTY ACQUISITION
  - DEPARTURE SURFACE TREE OBSTRUCTIONS
  - EXISTING AIRPORT PROPERTY
  - OFA PENETRATIONS
  - ULTIMATE AIRPORT PROPERTY (FEE/A&H EASEMENT)

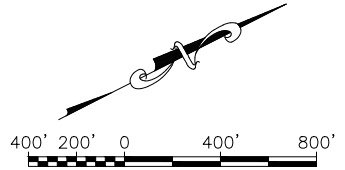

PLANS DEVELOPED BY: R&M CONSULTANTS, INC. 9101 VANGUARD DR. ANCHORAGE, AK 99507 (907) 522-1707 CERT. OF AUTH. NO. AECC111		
BY	DATE	REVISION

**STATE OF ALASKA**  
**DEPARTMENT OF TRANSPORTATION**  
**AND PUBLIC FACILITIES**  
 4111 AVIATION AVE., ANCHORAGE ALASKA 99502  
 PHONE (907) 269-0590

**DILLINGHAM AIRPORT**  
 DILLINGHAM, ALASKA  
 AIRPORT MASTER PLAN  
 PROJECT No. CFAPT00353  
 AIP No. 3-02-0078-017-2018  
 ALTERNATIVE OVERVIEW

DATE:  
3/15/2022  
 SHEET:  
2 OF 2

Date Revised: 3/22/2022, 11:05 AM  
 Layout Name: 1  
 File Path and Name: Z:\Project\2820.01 DOT\_C DLG AMP Update\Civil\ACAD\Alternatives\Alternative 1\2021-09-22\_Design\3D\_2021\_00353-DLG-Alternative\_1.dwg  
 Designed By: MM  
 Drawn By: AWA/RLC  
 Checked By: CJB

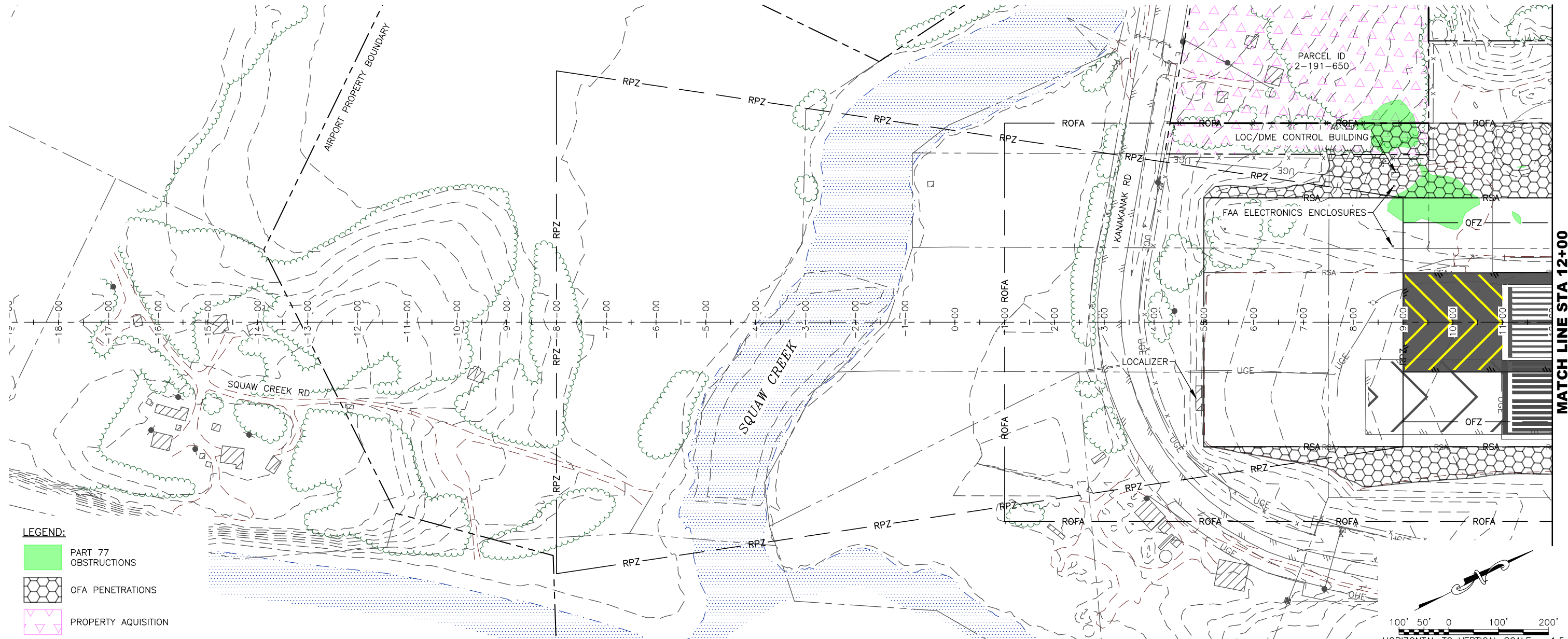

- LEGEND:**
- PART 77 OBSTRUCTIONS
  - OFA PENETRATIONS
  - PROPERTY ACQUISITION

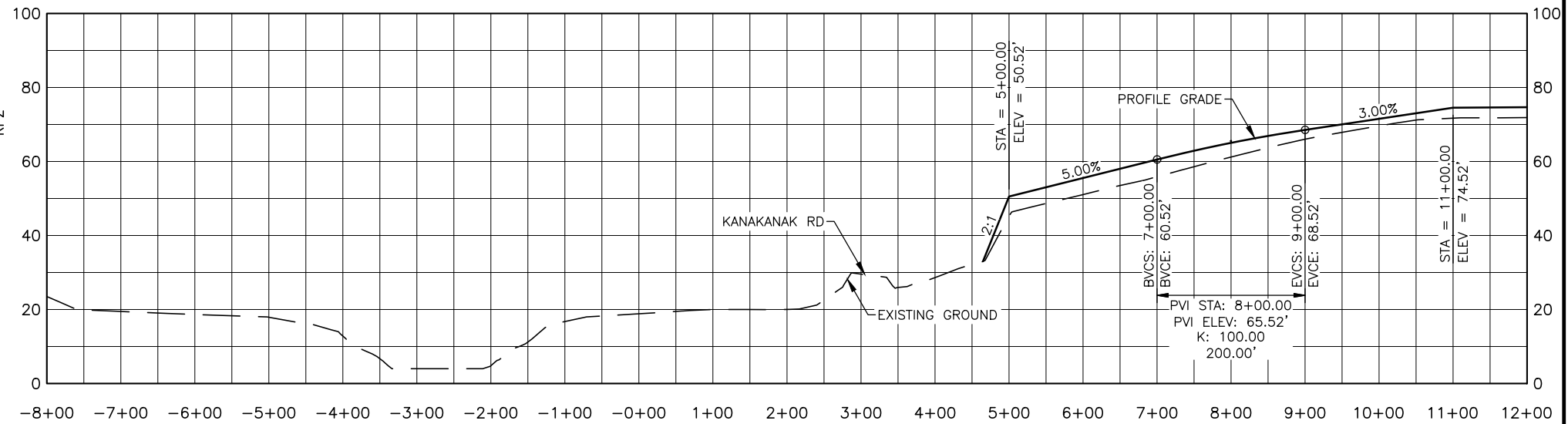
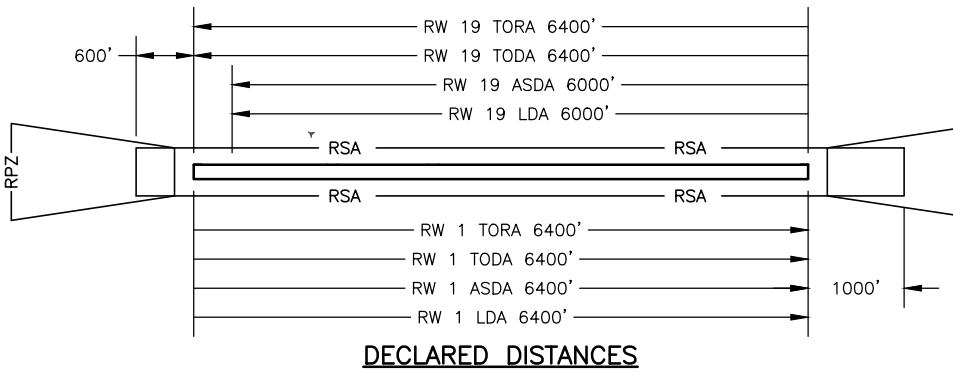

- IMPACTS:**
1. RUNWAY OFFSET 150' WEST OF EXISTING POSITION.
  2. CONSTRUCT EMBANKMENT FOR RSA ON WEST SIDE.
  3. ADJUST LOC POSITION TO ALIGN WITH OFFSET RUNWAY.
  4. LOC/DME CONTROL BUILDING TO BE RELOCATED OUTSIDE OF ROFA.
  5. FAA ELECTRONICS ENCLOSURES TO BE RELOCATED OUTSIDE OF ROFA.
  6. PROPERTY ACQUISITION TO CONTROL ROFA.
  7. ADJUST AIRPORT PERIMETER FENCING.
  8. TERRAIN REMOVAL.
  9. OBSTRUCTION REMOVAL.
  10. REPLACE AIRPORT LIGHTING SYSTEM.

PLANS DEVELOPED BY: R&M CONSULTANTS, INC. 9101 VANGUARD DR. ANCHORAGE, AK 99507 (907) 522-1707 CERT. OF AUTH. NO. AECC111		
BY	DATE	REVISION

**STATE OF ALASKA**  
**DEPARTMENT OF TRANSPORTATION**  
**AND PUBLIC FACILITIES**  
**CENTRAL REGION**  
 4111 AVIATION AVE., ANCHORAGE ALASKA 99502  
 PHONE (907) 269-0590

**DILLINGHAM AIRPORT**  
 DILLINGHAM, ALASKA  
 AIRPORT MASTER PLAN  
 PROJECT No. CFAPT00353  
 AIP No. 3-02-0078-017-2018  
 ALTERNATIVE No. 1  
 NO GRADE CORRECTION

DATE:  
 3/22/2022  
 SHEET:  
 1 OF 4

MATCH LINE STA 12+00

Date Revised: 3/22/2022, 11:05 AM  
 Layout Name: 2  
 File Path and Name: Z:\project\2820.01 DOT\_C DLG AMP Update\Civil\ACAD\Alternatives\Alternative 1\2021-09-22\_Design\3D\2021\_00353-DLG-Alternative\_1.dwg  
 Designed By: MM  
 Drawn By: AWA/RLC  
 Checked By: CJB

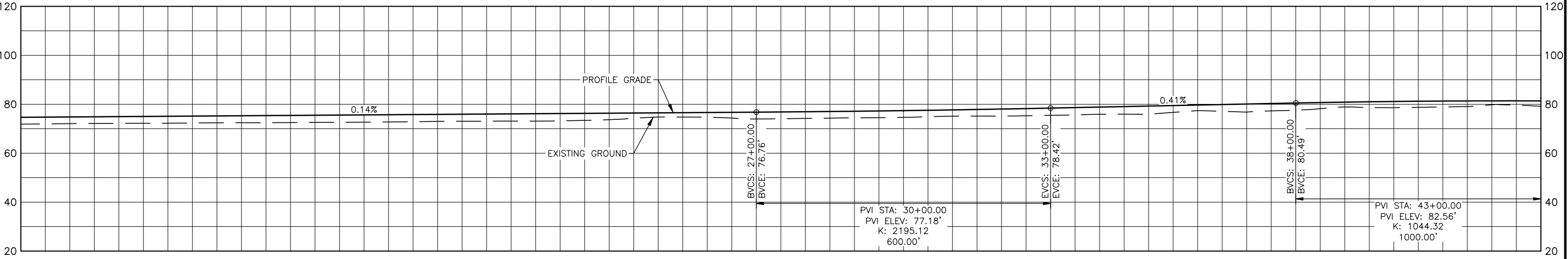
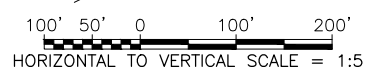
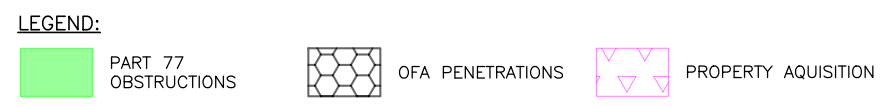
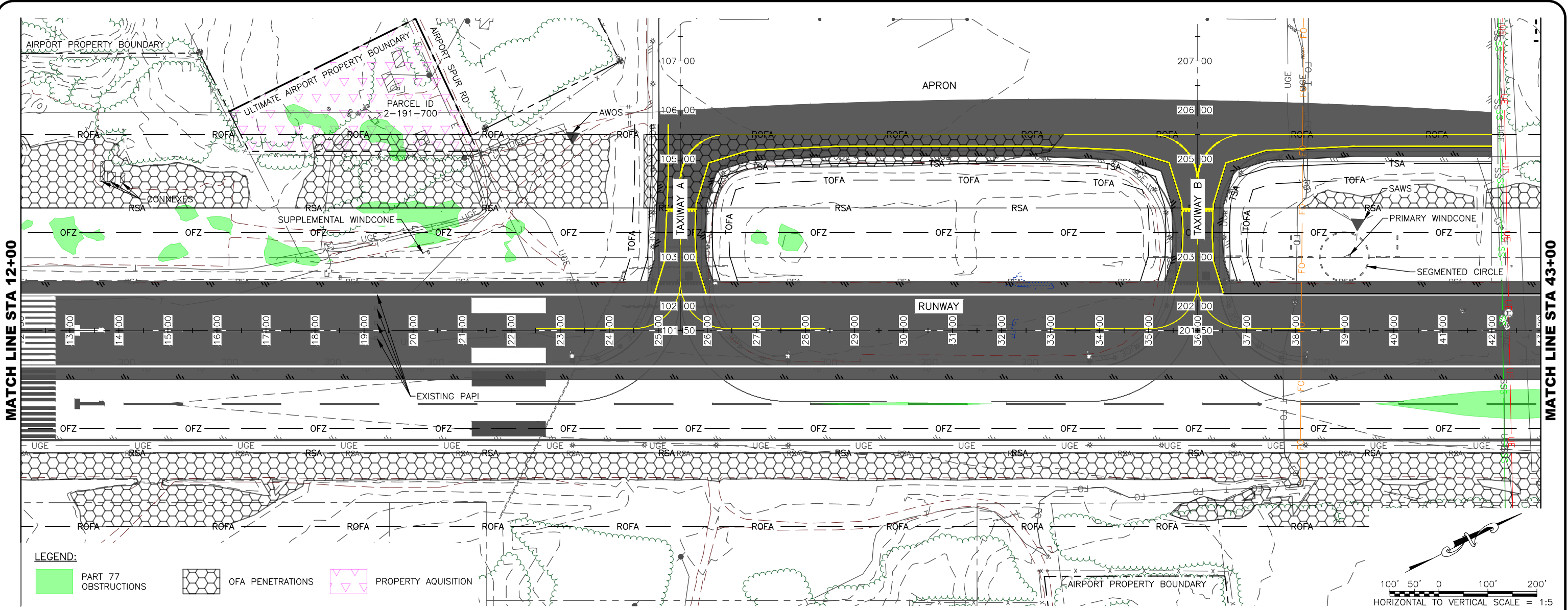

**IMPACTS:**

1. RUNWAY OFFSET 150' WEST OF EXISTING POSITION.
2. CONSTRUCT EMBANKMENT FOR RSA ON WEST SIDE.
3. RELOCATE AWOS, SAWS ANTENNA, PRIMARY WINDCONE, SEGMENTED CIRCLE, AND SUPPLEMENTAL WINDCONE.
4. RELOCATE AIRPORT SPUR ROAD AND BUILDINGS OUTSIDE OF ROFA.
5. PAPI RELOCATION.
6. SANITARY SEWER SYSTEM, UNDERGROUND ELECTRIC, AND FIBER OPTIC ADJUSTMENTS.
7. PROPERTY ACQUISITION TO CONTROL ROFA.
8. ADJUST AIRPORT PERIMETER FENCING.
9. TERRAIN REMOVAL.
10. OBSTRUCTION REMOVAL.
11. REPLACE AIRPORT LIGHTING SYSTEM.
12. EXTEND 42" DIA. RUNWAY CROSS CULVERT 150'.
13. REPLACE TAXIWAY A AND TAXIWAY B 42" DIA. CROSS CULVERTS.

PLANS DEVELOPED BY: R&M CONSULTANTS, INC. 9101 VANGUARD DR. ANCHORAGE, AK 99507 (907) 522-1707 CERT. OF AUTH. NO. AECC111		
BY	DATE	REVISION

**STATE OF ALASKA**  
**DEPARTMENT OF TRANSPORTATION**  
**AND PUBLIC FACILITIES**  
 4111 AVIATION AVE., ANCHORAGE ALASKA 99502  
 PHONE (907) 269-0590

**DILLINGHAM AIRPORT**  
 DILLINGHAM, ALASKA  
 AIRPORT MASTER PLAN  
 PROJECT No. CFAPT00353  
 AIP No. 3-02-0078-017-2018  
 ALTERNATIVE No. 1  
 NO GRADE CORRECTION

DATE: 3/22/2022  
 SHEET: 2 OF 4



Date Revised: 3/22/2022, 11:05 AM  
 Layout Name: 3  
 File Path and Name: Z:\project\2820.01 DOT\_C DIG AMP Update\Civil\ACAD\Alternatives\Alternative 1\2021-09-22\_Design\3D\_2021\_00353-DIG-Alternative\_1.dwg  
 Designed By: MM  
 Drawn By: AWA/RLC  
 Checked By: CJB

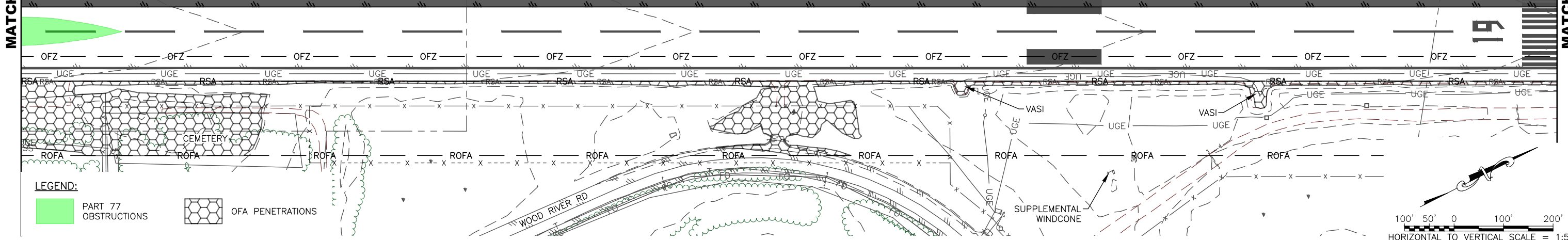
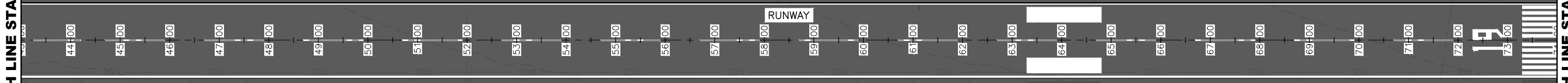
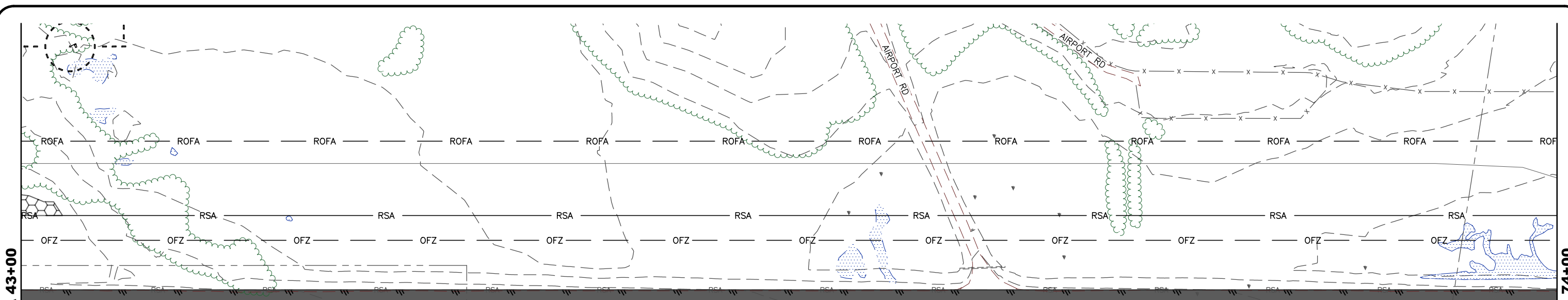

**LEGEND:**

PART 77 OBSTRUCTIONS  
 OFA PENETRATIONS

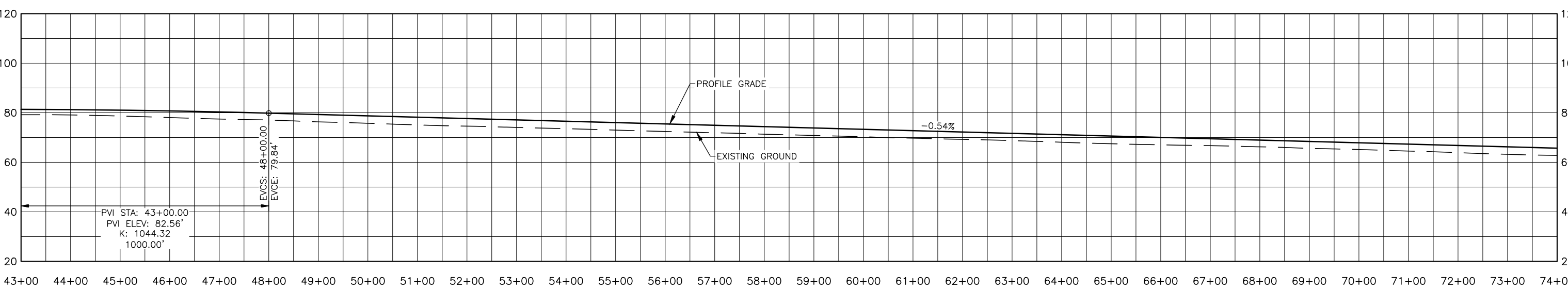
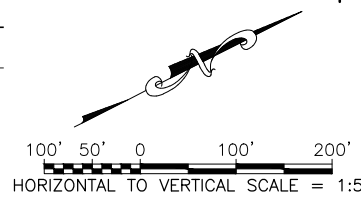

- IMPACTS:**
1. RUNWAY OFFSET 150' WEST OF EXISTING POSITION.
  2. CONSTRUCT EMBANKMENT FOR RSA ON WEST SIDE.
  3. REPLACE VASI SYSTEM WITH PAPI SYSTEM.
  4. REALIGN WOOD RIVER RD AND ADJACENT FIBER OPTIC AND TELEPHONE UTILITY OUTSIDE OF ROFA.
  5. ADJUST AIRPORT PERIMETER FENCING.
  6. TERRAIN REMOVAL.
  7. REPLACE AIRPORT LIGHTING SYSTEM.

PLANS DEVELOPED BY: R&M CONSULTANTS, INC. 9101 VANGUARD DR. ANCHORAGE, AK 99507 (907) 522-1707 CERT. OF AUTH. NO. AECC111		
BY	DATE	REVISION

**STATE OF ALASKA**  
**DEPARTMENT OF TRANSPORTATION**  
**AND PUBLIC FACILITIES**  
 4111 AVIATION AVE., ANCHORAGE ALASKA 99502  
 PHONE (907) 269-0590

**DILLINGHAM AIRPORT**  
 DILLINGHAM, ALASKA  
 AIRPORT MASTER PLAN  
 PROJECT No. CFAPT00353  
 AIP No. 3-02-0078-017-2018  
 ALTERNATIVE No. 1  
 NO GRADE CORRECTION

DATE: 3/22/2022  
 SHEET: 3 OF 4

Date Revised: 3/22/2022, 11:05 AM  
 Layout Name: 4  
 File Path and Name: Z:\project\2820.01 DOT\_C DUG AMP Update\Civil\ACAD\Alternatives\Alternative 1\2021-09-22\_Design\3D\_2021\_00353-DLG-Alternative\_1.dwg  
 Designed By: MM  
 Drawn By: AWA/RLC  
 Checked By: CJB

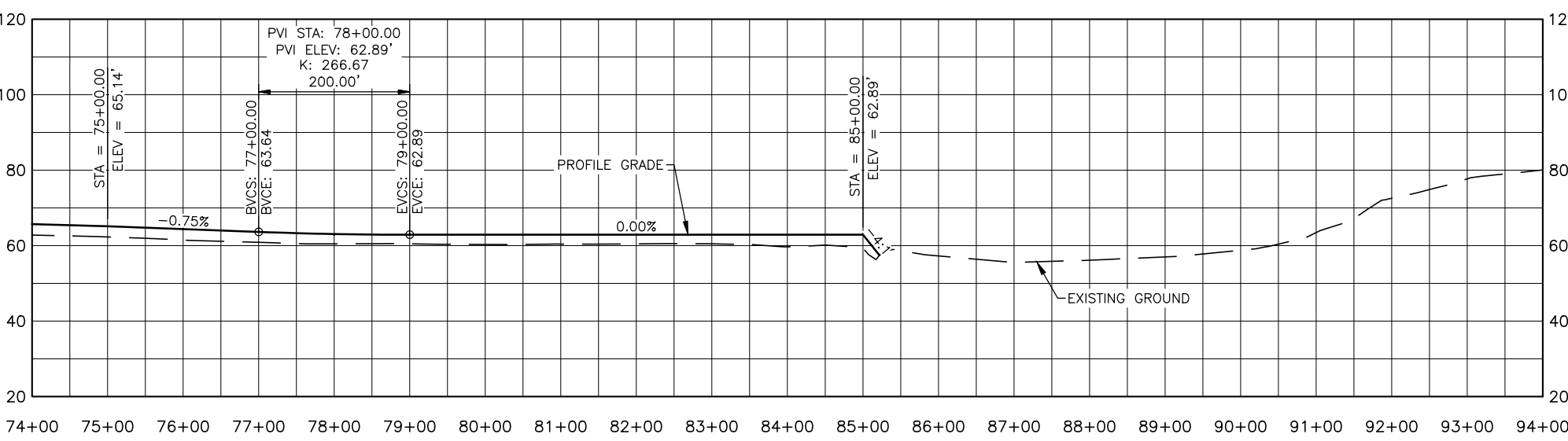
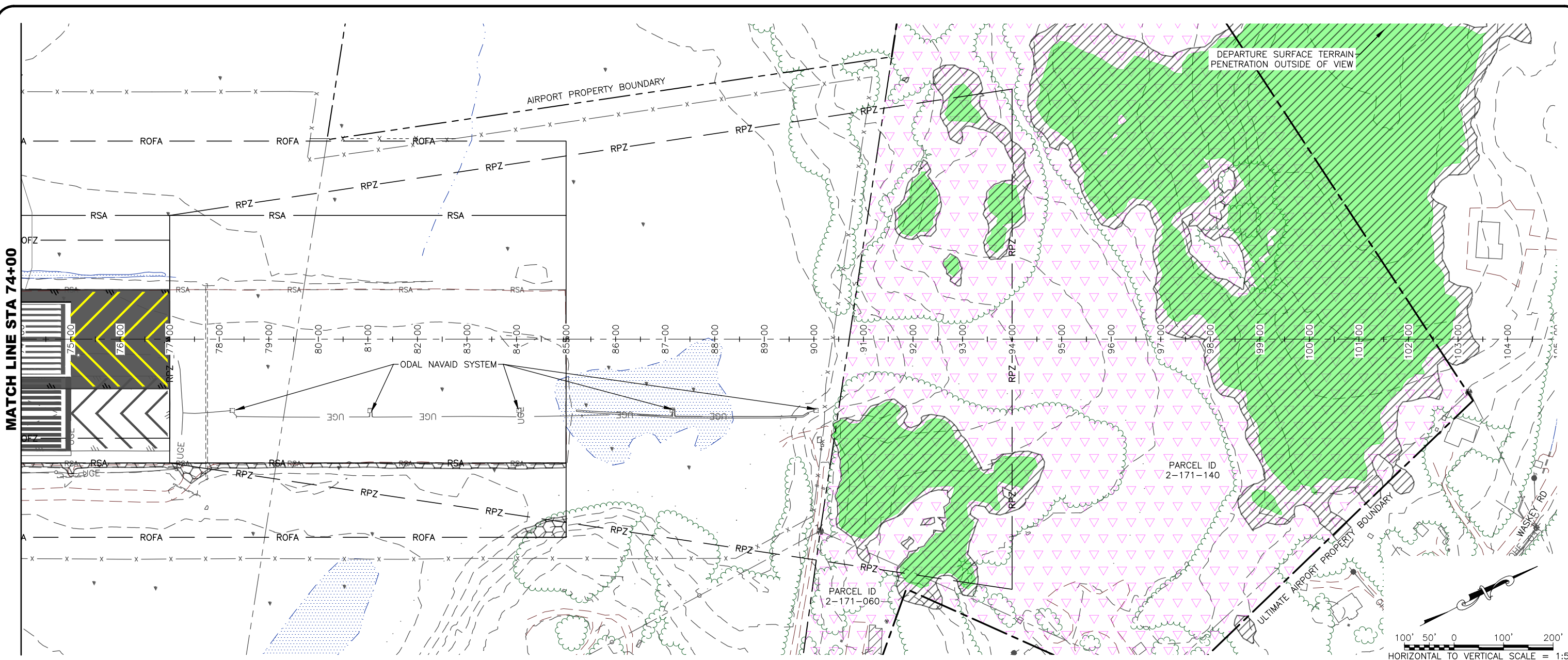

- LEGEND:**
- PART 77 TREE OBSTRUCTIONS
  - DEPARTURE SURFACE TREE OBSTRUCTIONS
  - OFA PENETRATIONS
  - PROPERTY ACQUISITION

- IMPACTS:**
1. RUNWAY OFFSET 150' WEST OF EXISTING POSITION.
  2. CONSTRUCT EMBANKMENT FOR RSA ON WEST SIDE.
  3. RELOCATE ODAL NAVD SYSTEM.
  4. OBSTRUCTION REMOVAL.
  5. TERRAIN REMOVAL.
  6. PROPERTY ACQUISITION FOR CONTROL OF RPZ.
  7. ADJUST AIRPORT PERIMETER FENCING.
  8. REPLACE AIRPORT LIGHTING SYSTEM.
  9. EXTEND 42" DIA. RUNWAY CROSS CULVERT 150'.

**PLANS DEVELOPED BY:**  
**R&M CONSULTANTS, INC.**  
 9101 VANGUARD DR.  
 ANCHORAGE, AK 99507  
 (907) 522-1707  
 CERT. OF AUTH. NO. AECC111

BY	DATE	REVISION

**STATE OF ALASKA**  
**DEPARTMENT OF TRANSPORTATION**  
**AND PUBLIC FACILITIES**  
 4111 AVIATION AVE., ANCHORAGE ALASKA 99502  
 PHONE (907) 269-0590

**DILLINGHAM AIRPORT**  
 DILLINGHAM, ALASKA  
 AIRPORT MASTER PLAN  
 PROJECT No. CFAPT00353  
 AIP No. 3-02-0078-017-2018  
 ALTERNATIVE No. 1  
 NO GRADE CORRECTION

DATE:  
 3/22/2022  
 SHEET:  
 4 OF 4

Date Revised: 3/22/2022, 10:56 AM  
 Layout Name: 1  
 File Path and Name: Z:\project\2820.01 DOT\_C DLG AMP Update\Civil\ACAD\Alternatives\Alternative 2\00353-DLG-Alternative\_2.dwg  
 Designed By: MM  
 Drawn By: AWA/RLC  
 Checked By: CJB

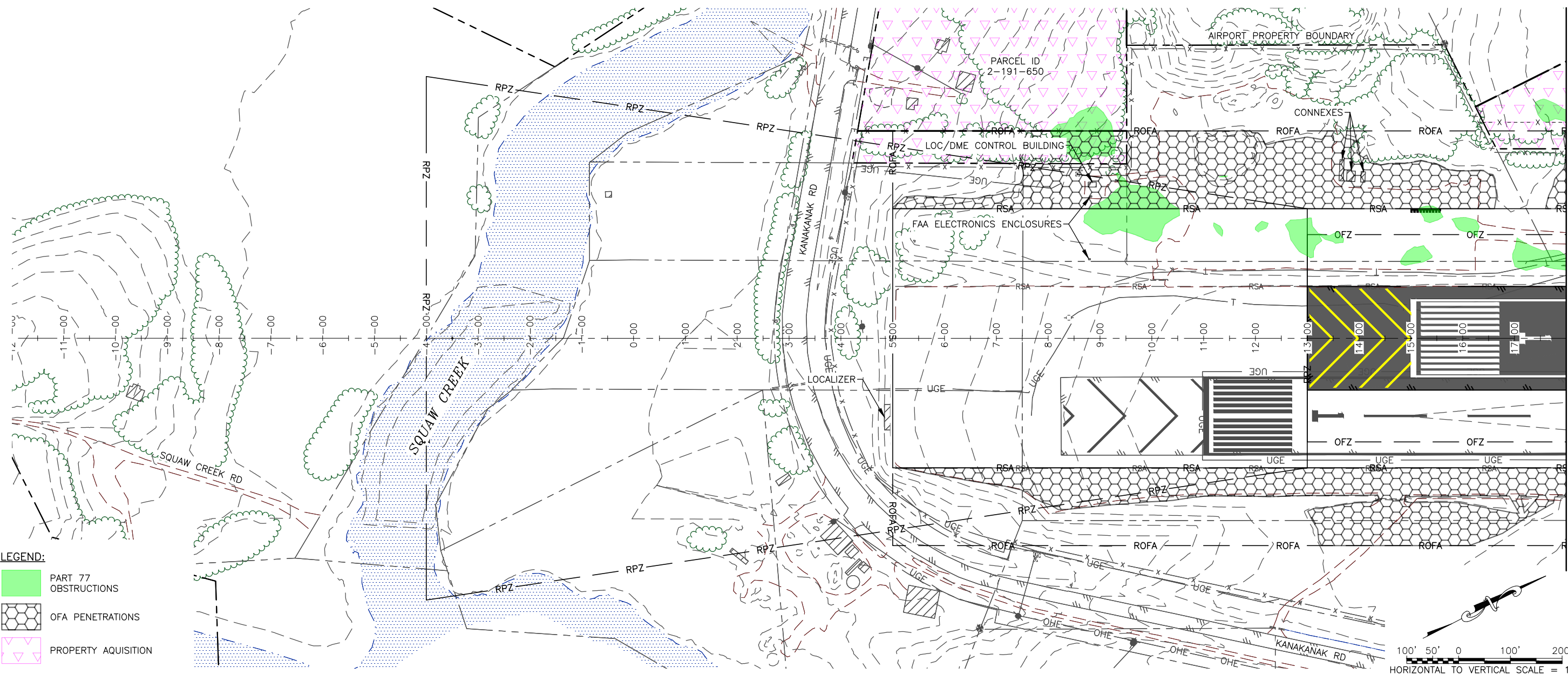

**LEGEND:**

- PART 77 OBSTRUCTIONS
- OFA PENETRATIONS
- PROPERTY ACQUISITION



- IMPACTS:**
1. RUNWAY OFFSET 150' WEST OF EXISTING POSITION AND RW 1 THRESHOLD SHIFTED 400' TO THE NORTH.
  2. CONSTRUCT EMBANKMENT FOR RSA ON WEST SIDE.
  3. ADJUST LOC POSITION TO ALIGN WITH OFFSET RUNWAY.
  4. LOC/DME CONTROL BUILDING TO BE RELOCATED OUTSIDE OF ROFA.
  5. FAA ELECTRONICS ENCLOSURES TO BE RELOCATED OUTSIDE OF ROFA.
  6. PROPERTY ACQUISITION TO CONTROL ROFA.
  7. ADJUST AIRPORT PERIMETER FENCING.
  8. TERRAIN REMOVAL.
  9. OBSTRUCTION REMOVAL.
  10. REPLACE AIRPORT LIGHTING SYSTEM.

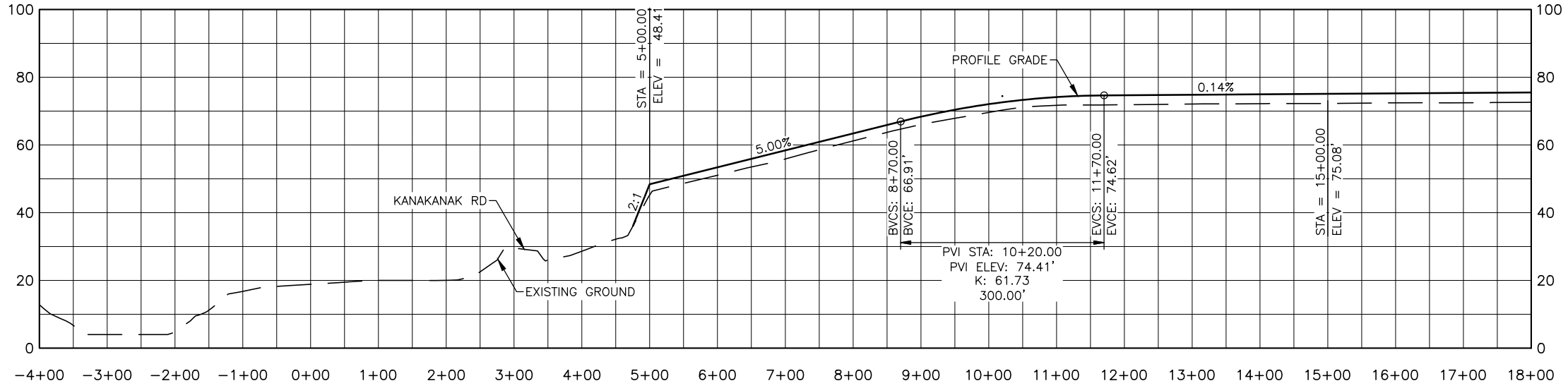

PLANS DEVELOPED BY: R&M CONSULTANTS, INC. 9101 VANGUARD DR. ANCHORAGE, AK 99507 (907) 522-1707 CERT. OF AUTH. NO. AECC111		
BY	DATE	REVISION

**STATE OF ALASKA**  
**DEPARTMENT OF TRANSPORTATION**  
**AND PUBLIC FACILITIES**  
 CENTRAL REGION  
 4111 AVIATION AVE., ANCHORAGE ALASKA 99502  
 PHONE (907) 269-0590

**DILLINGHAM AIRPORT**  
 DILLINGHAM, ALASKA  
 AIRPORT MASTER PLAN  
 PROJECT No. CFAPT00353  
 AIP No. 3-02-0078-017-2018  
 ALTERNATIVE No. 2  
 NO GRADE CORRECTION

DATE:  
 3/22/2022  
 SHEET:  
 1 OF 4

MATCH LINE STA 18+00

Designed By: MM  
 Drawn By: AWA/RLC  
 Checked By: CJB

Date Revised: 3/22/2022, 10:56 AM  
 Layout Name: 2  
 File Path and Name: Z:\project\2820\01 DOT\_C DIG AMP Update\Civil\ACAD\Alternatives\Alternative 2\00053-DIG-Alternative\_2.dwg

MATCH LINE STA 18+00

MATCH LINE STA 48+00

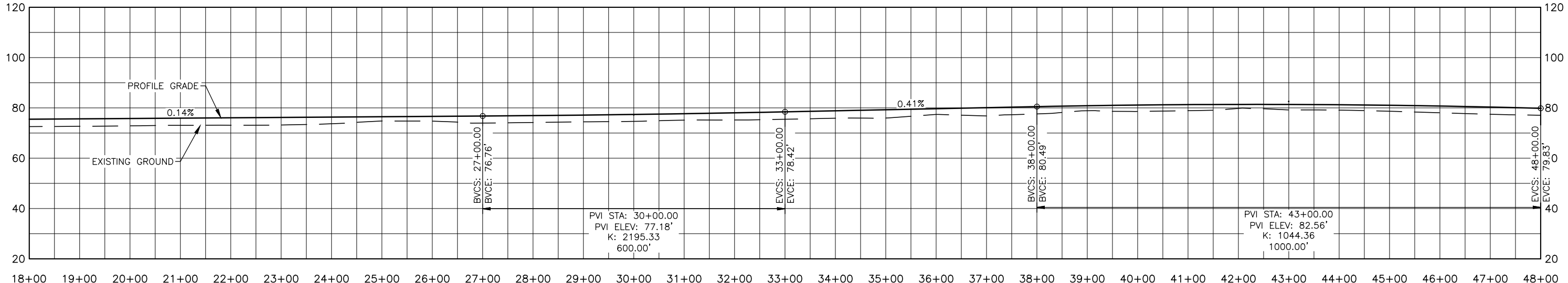
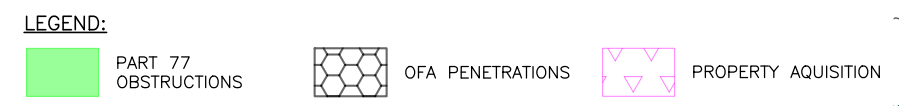
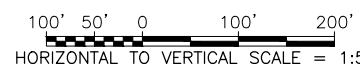
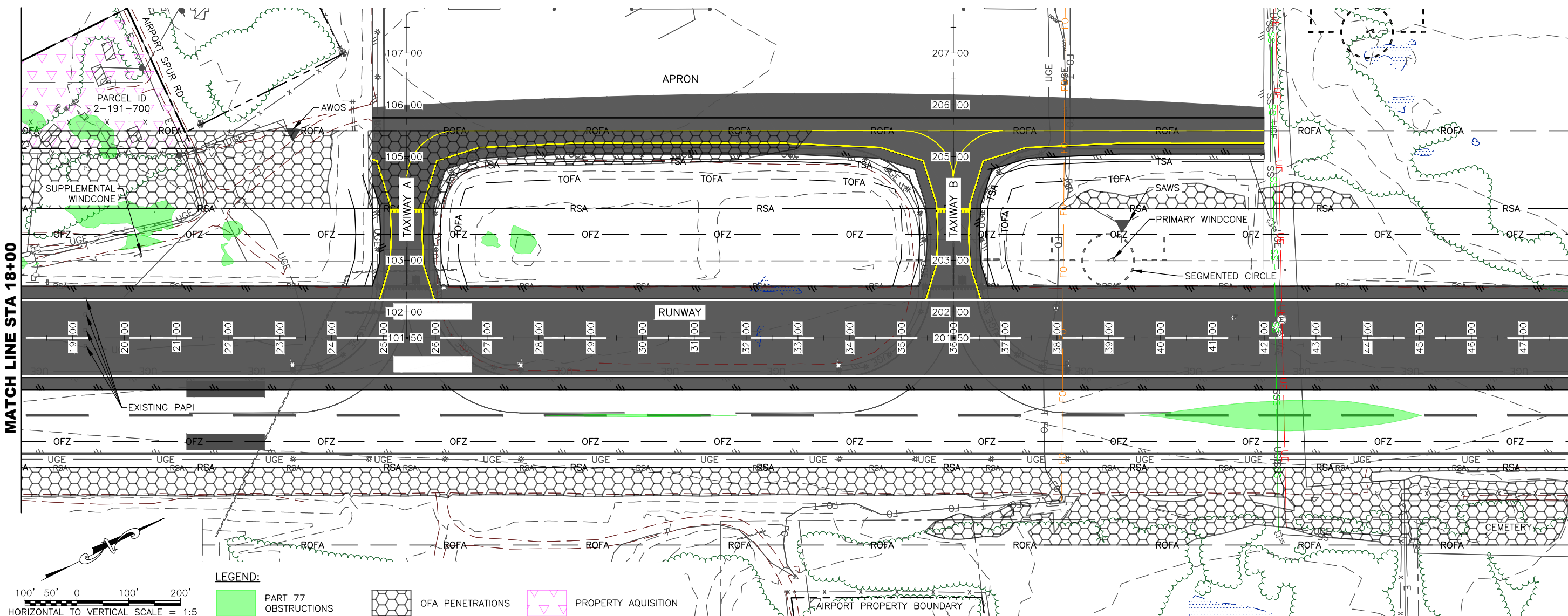

**IMPACTS:**

- |  |  |                                      |  |
|--|--|--------------------------------------|--|
| 1. RUNWAY OFFSET 150' WEST OF EXISTING POSITION.   | 5. PAPI RELOCATION.  | 10. OBSTRUCTION REMOVAL.             | 12. EXTEND 42" DIA. RUNWAY CROSS CULVERT 150'.               |
| 2. CONSTRUCT EMBANKMENT FOR RSA ON WEST SIDE.  | 6. SANITARY SEWER SYSTEM, UNDERGROUND ELECTRIC, AND FIBER OPTIC ADJUSTMENTS. | 11. REPLACE AIRPORT LIGHTING SYSTEM. | 13. REPLACE TAXIWAY A AND TAXIWAY B 42" DIA. CROSS CULVERTS. |
| 3. RELOCATE AWOS, SAWS ANTENNA, PRIMARY WINDCONE, SEGMENTED CIRCLE, AND SUPPLEMENTAL WINDCONE. | 7. PROPERTY ACQUISITION TO CONTROL ROFA.                                     |                                      |  |
| 4. RELOCATE AIRPORT SPUR ROAD AND BUILDINGS OUTSIDE OF ROFA.                                   | 8. ADJUST AIRPORT PERIMETER FENCING.   |                                      |  |
|  | 9. TERRAIN REMOVAL.  |                                      |  |

PLANS DEVELOPED BY: R&M CONSULTANTS, INC. 9101 VANGUARD DR. ANCHORAGE, AK 99507 (907) 522-1707 CERT. OF AUTH. NO. AECC111		
BY	DATE	REVISION

**STATE OF ALASKA  
 DEPARTMENT OF TRANSPORTATION  
 AND PUBLIC FACILITIES**  
 4111 AVIATION AVE., ANCHORAGE ALASKA 99502  
 PHONE (907) 269-0590

**DILLINGHAM AIRPORT  
 DILLINGHAM, ALASKA**  
 AIRPORT MASTER PLAN  
 PROJECT No. CFAPT00353  
 AIP No. 3-02-0078-017-2018  
 ALTERNATIVE No. 2  
 NO GRADE CORRECTION

DATE:  
3/22/2022  
SHEET:  
2 OF 4

Date Revised: 3/22/2022, 10:56 AM  
 Layout Name: 3  
 File Path and Name: Z:\project\2820\01 DOT\_C DIG AMP Update\Civil\ACAD\Alternatives\Alternative 2\002853-DLG-Alternative\_2.dwg  
 Designed By: MM  
 Drawn By: AWA/RLC  
 Checked By: CJB

MATCH LINE STA 48+00

MATCH LINE STA 78+00

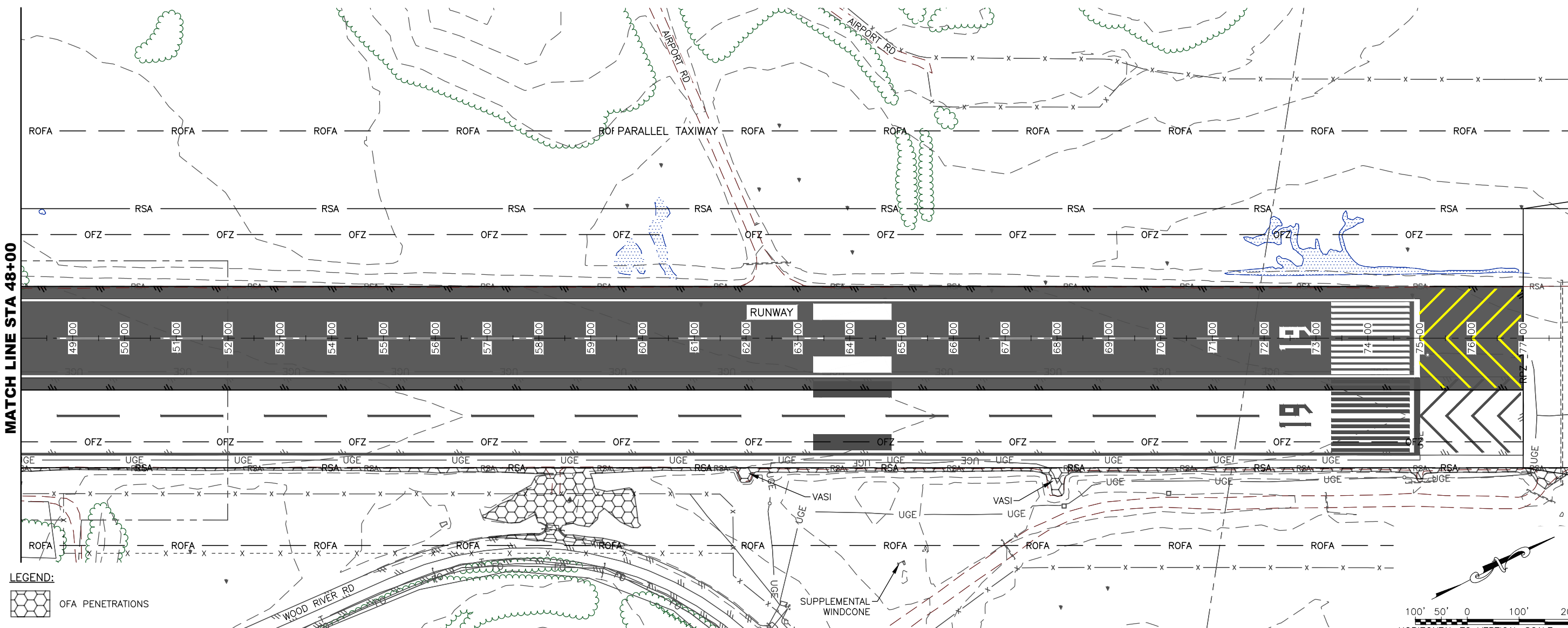

**LEGEND:**  
 OFA PENETRATIONS

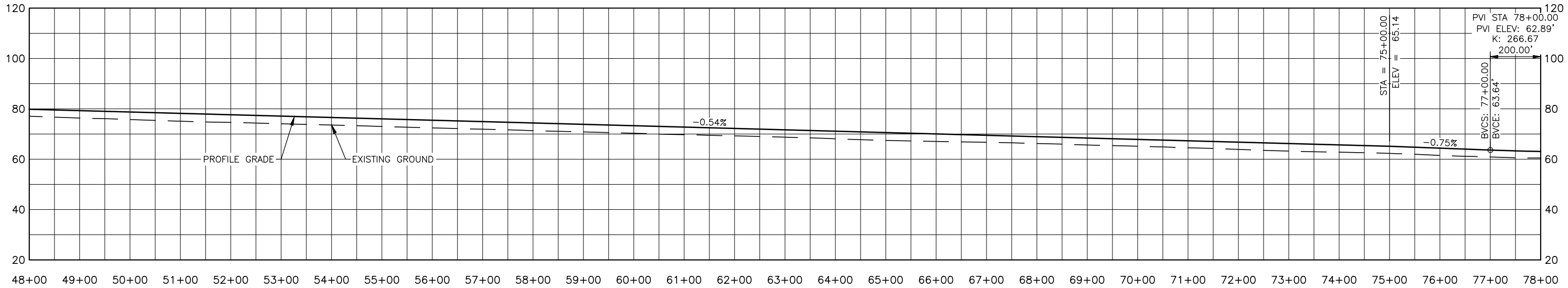
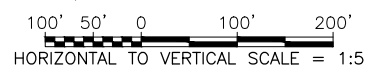

**IMPACTS:**

1. RUNWAY OFFSET 150' WEST OF EXISTING POSITION.
2. CONSTRUCT EMBANKMENT FOR RSA ON WEST SIDE.
3. RELOCATE VASI SYSTEM.
4. REALIGN WOOD RIVER RD AND ADJACENT FIBER OPTIC AND TELEPHONE UTILITY OUTSIDE OF ROFA.
5. ADJUST AIRPORT PERIMETER FENCING.
6. TERRAIN REMOVAL.
7. REPLACE AIRPORT LIGHTING SYSTEM.
8. EXTEND 42" DIA. RUNWAY CROSS CULVERT 150'.

BY	DATE	REVISION

**STATE OF ALASKA**  
**DEPARTMENT OF TRANSPORTATION**  
**AND PUBLIC FACILITIES**  
 4111 AVIATION AVE., ANCHORAGE ALASKA 99502  
 PHONE (907) 269-0590

**DILLINGHAM AIRPORT**  
 DILLINGHAM, ALASKA  
 AIRPORT MASTER PLAN  
 PROJECT No. CFAPT00353  
 AIP No. 3-02-0078-017-2018  
 ALTERNATIVE No. 2  
 NO GRADE CORRECTION

DATE: 3/22/2022  
 SHEET: 3 OF 4

**PLANS DEVELOPED BY:**  
**R&M CONSULTANTS, INC.**  
 9101 VANGUARD DR.  
 ANCHORAGE, AK 99507  
 (907) 522-1707  
 CERT. OF AUTH. NO. AECC111

Date Revised: 3/22/2022, 10:56 AM  
 Layout Name: 4  
 File Path and Name: Z:\project\2820\01 DOT\_C DIG AMP Update\Civil\ACAD\Alternatives\Alternative 2\00353-DLG-Alternative\_2.dwg  
 Designed By: MM  
 Drawn By: AWA/RLC  
 Checked By: CJB

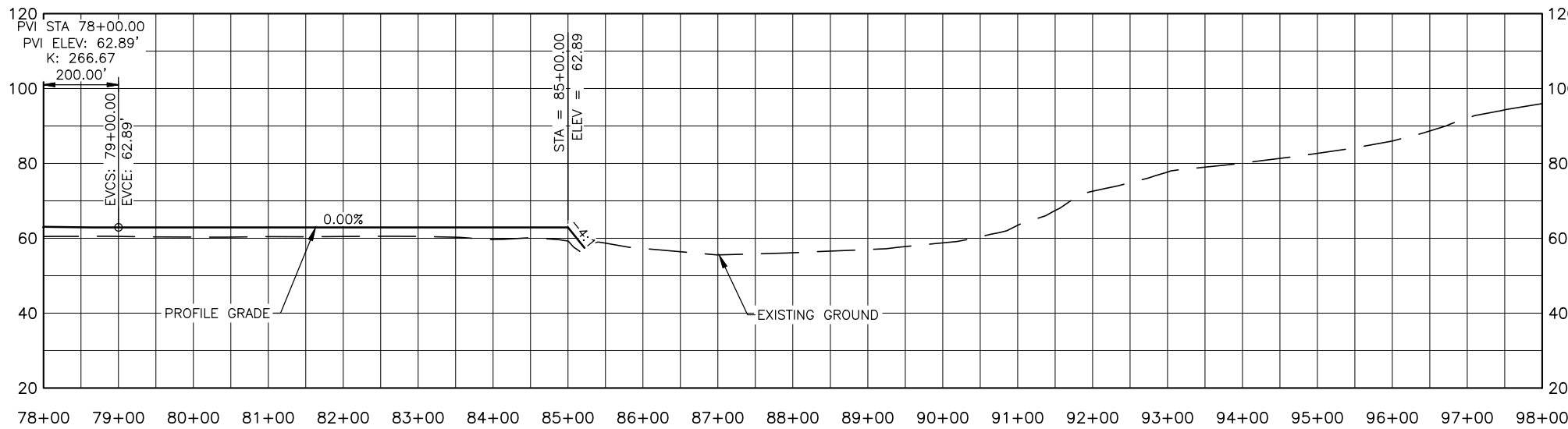
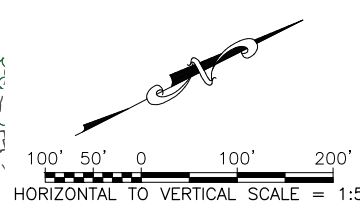
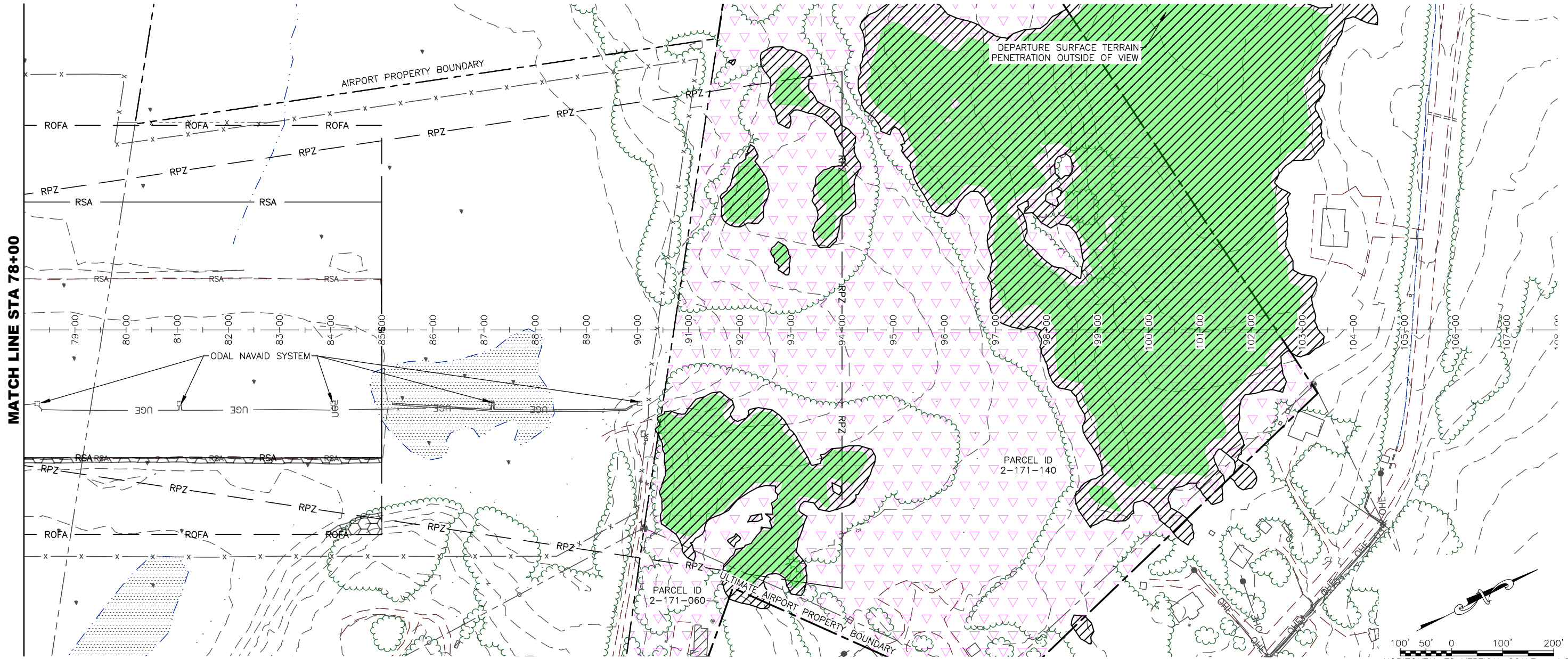

**LEGEND:**

- PART 77 TREE OBSTRUCTIONS
- DEPARTURE SURFACE TREE OBSTRUCTIONS
- OFA PENETRATIONS
- PROPERTY ACQUISITION

**IMPACTS:**

1. RUNWAY OFFSET 150' WEST OF EXISTING POSITION.
2. CONSTRUCT EMBANKMENT FOR RSA ON WEST SIDE.
3. RELOCATE ODAL NAVAID SYSTEM.
4. OBSTRUCTION REMOVAL.
5. TERRAIN REMOVAL.
6. PROPERTY ACQUISITION FOR CONTROL OF RPZ.
7. ADJUST AIRPORT PERIMETER FENCING.
8. REPLACE AIRPORT LIGHTING SYSTEM.

**PLANS DEVELOPED BY:**  
**R&M CONSULTANTS, INC.**  
 9101 VANGUARD DR.  
 ANCHORAGE, AK 99507  
 (907) 522-1707  
 CERT. OF AUTH. NO. AECC111

BY	DATE	REVISION

**STATE OF ALASKA**  
**DEPARTMENT OF TRANSPORTATION**  
**AND PUBLIC FACILITIES**  
 4111 AVIATION AVE., ANCHORAGE ALASKA 99502  
 PHONE (907) 269-0590

**DILLINGHAM AIRPORT**  
 DILLINGHAM, ALASKA  
 AIRPORT MASTER PLAN  
 PROJECT No. CFAPT00353  
 AIP No. 3-02-0078-017-2018  
 ALTERNATIVE No. 2  
 NO GRADE CORRECTION

DATE: 3/22/2022  
 SHEET: 4 OF 4

Date Revised: 3/22/2022, 11:14 AM  
 Layout Name: 1  
 File Path and Name: Z:\project\2820\01 DOT\_C DLG AMP Update\Civil\ACAD\Alternatives\Alternative 3\00053-DLG-Alternative\_3.dwg  
 Designed By: MM  
 Drawn By: AWA/RLC  
 Checked By: CJB

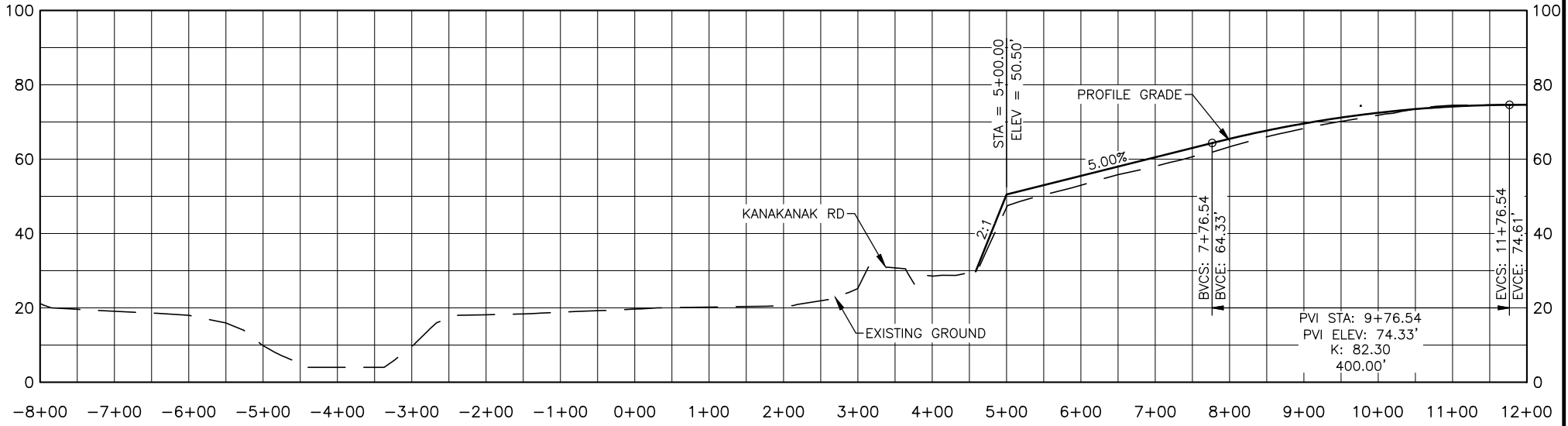
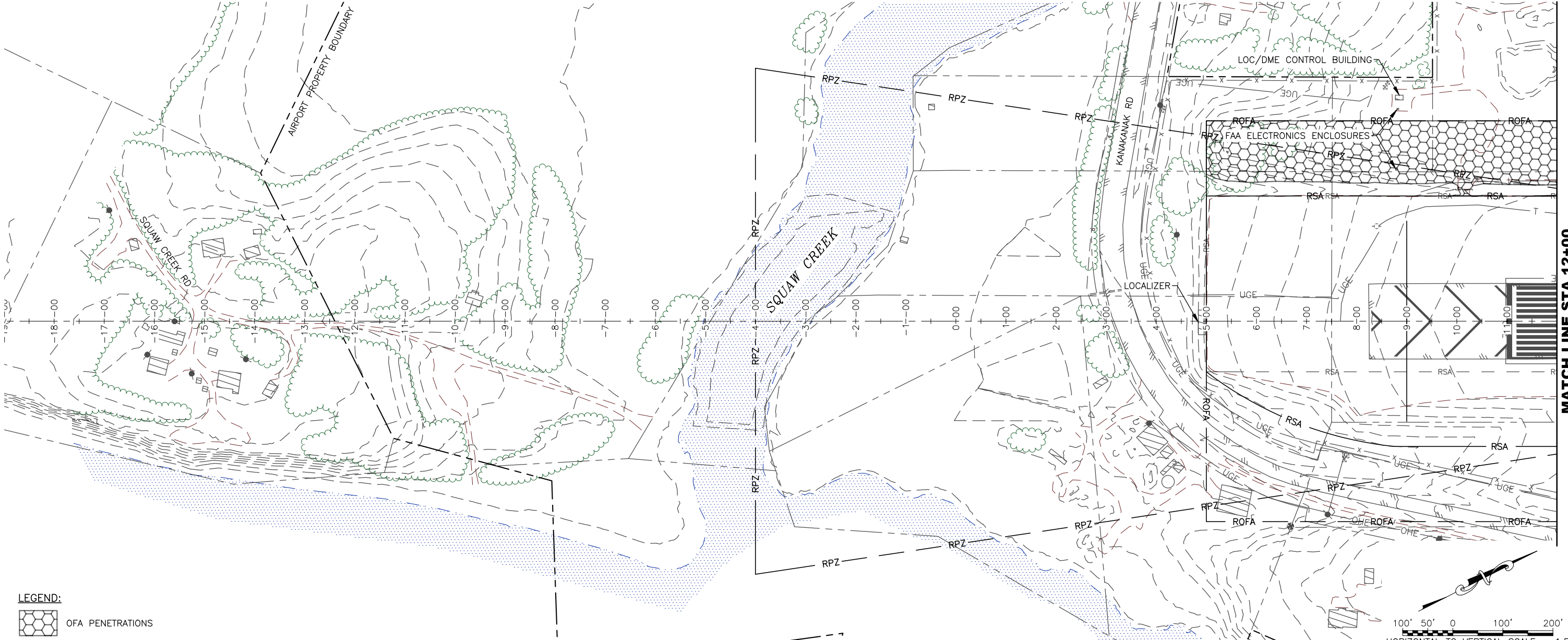

**PLANS DEVELOPED BY:**  
**R&M CONSULTANTS, INC.**  
 9101 VANGUARD DR.  
 ANCHORAGE, AK 99507  
 (907) 522-1707  
**CERT. OF AUTH. NO. AECC111**

BY	DATE	REVISION

**STATE OF ALASKA**  
**DEPARTMENT OF TRANSPORTATION**  
**AND PUBLIC FACILITIES**  
**CENTRAL REGION**  
 4111 AVIATION AVE., ANCHORAGE ALASKA 99502  
 PHONE (907) 269-0590

**DILLINGHAM AIRPORT**  
 DILLINGHAM, ALASKA  
 AIRPORT MASTER PLAN  
 PROJECT No. CFAPT00353  
 AIP No. 3-02-0078-017-2018  
 ALTERNATIVE No. 3  
 NO GRADE CORRECTION

DATE:  
 3/22/2022  
 SHEET:  
 1 OF 4

Date Revised: 3/22/2022, 11:14 AM  
 Layout Name: 2  
 File Path and Name: Z:\project\2820\01 DOT\_C DLG AMP Update\Civil\ACAD\Alternatives\Alternative 3\00353-DLG-Alternative\_3.dwg  
 Designed By: MM  
 Drawn By: AW/RLC  
 Checked By: CJB

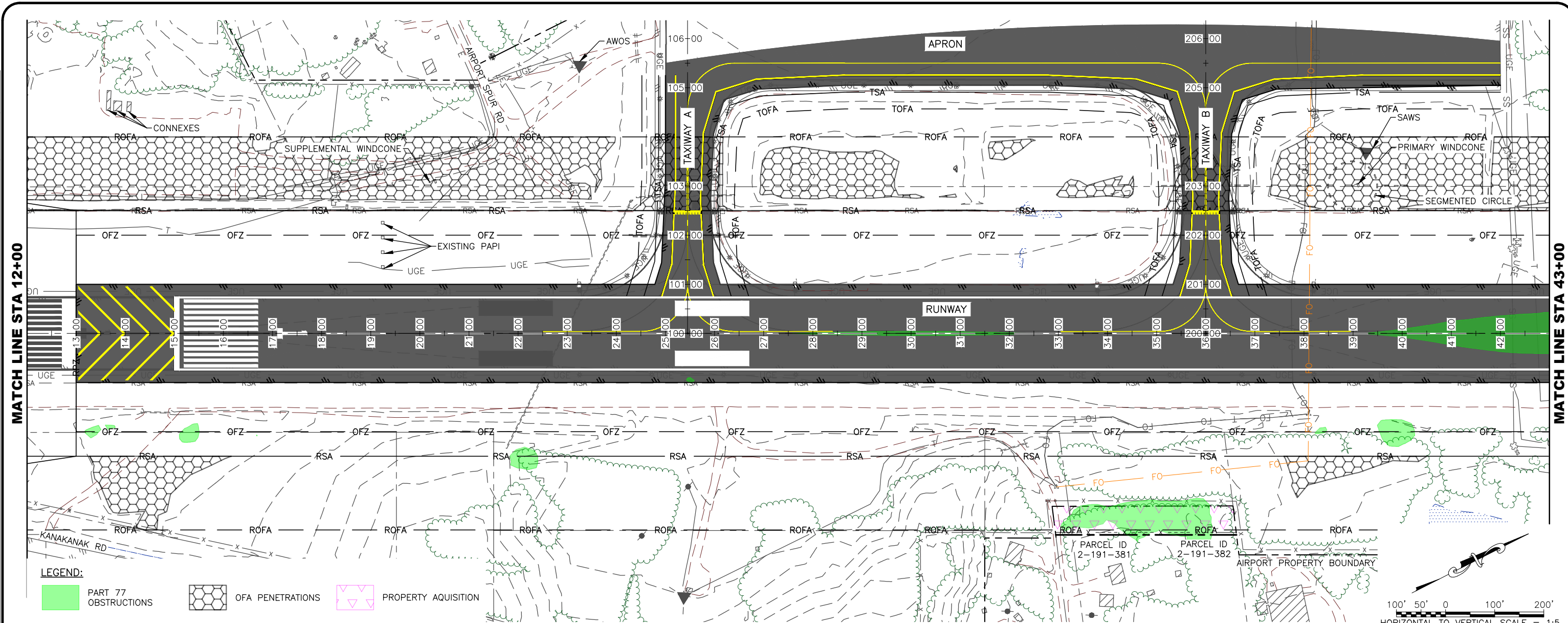

**LEGEND:**  
 PART 77 OBSTRUCTIONS  
 OFA PENETRATIONS  
 PROPERTY ACQUISITION

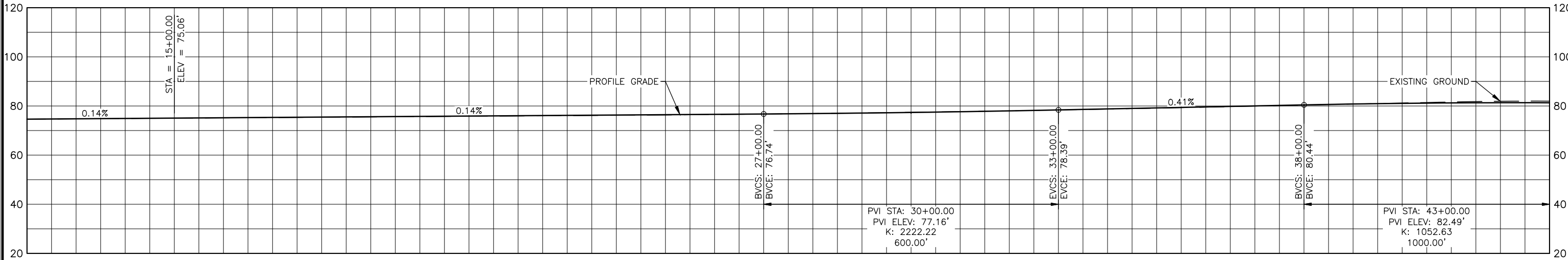
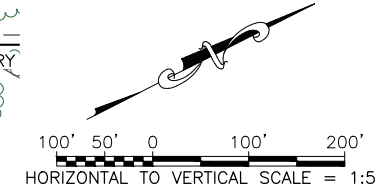

12+00 13+00 14+00 15+00 16+00 17+00 18+00 19+00 20+00 21+00 22+00 23+00 24+00 25+00 26+00 27+00 28+00 29+00 30+00 31+00 32+00 33+00 34+00 35+00 36+00 37+00 38+00 39+00 40+00 41+00 42+00 43+00

- IMPACTS:**
- CONSTRUCT EMBANKMENT FOR RSA ON EAST SIDE.
  - FIBER OPTIC ADJUSTMENTS.
  - RELOCATE PAPIs TO ACCOMMODATE RW 1 THRESHOLD SHIFT.
  - RELOCATE SAWS ANTENNA, PRIMARY WIND CONE, SEGMENTED CIRCLE, AND SUPPLEMENTAL WIND CONE OUTSIDE OF ROFA.
  - ADJUST AIRPORT PERIMETER FENCING.
  - ACQUIRE PROPERTY FOR ROFA CONTROL.
  - PART 77 OBSTRUCTION REMOVAL.
  - REPLACE AIRPORT LIGHTING SYSTEM.
  - EXTEND 42" DIA. RUNWAY CROSS CULVERT 150'.

PLANS DEVELOPED BY: R&M CONSULTANTS, INC. 9101 VANGUARD DR. ANCHORAGE, AK 99507 (907) 522-1707 CERT. OF AUTH. NO. AECC111		
BY	DATE	REVISION

**STATE OF ALASKA**  
**DEPARTMENT OF TRANSPORTATION**  
**AND PUBLIC FACILITIES**  
 4111 AVIATION AVE., ANCHORAGE ALASKA 99502  
 PHONE (907) 269-0590

**DILLINGHAM AIRPORT**  
 DILLINGHAM, ALASKA  
 AIRPORT MASTER PLAN  
 PROJECT No. CFAPT00353  
 AIP No. 3-02-0078-017-2018  
 ALTERNATIVE No. 3  
 NO GRADE CORRECTION

DATE:  
 3/22/2022  
 SHEET:  
 2 OF 4



Date Revised: 3/22/2022, 11:14 AM  
 Layout Name: 3  
 File Path and Name: Z:\project\2820\01 DOT\_C DIG AMP Update\Civil\ACAD\Alternatives\Alternative 3\00353-DLG-Alternative\_3.dwg  
 Designed By: MM  
 Drawn By: AWA/RLC  
 Checked By: CJB

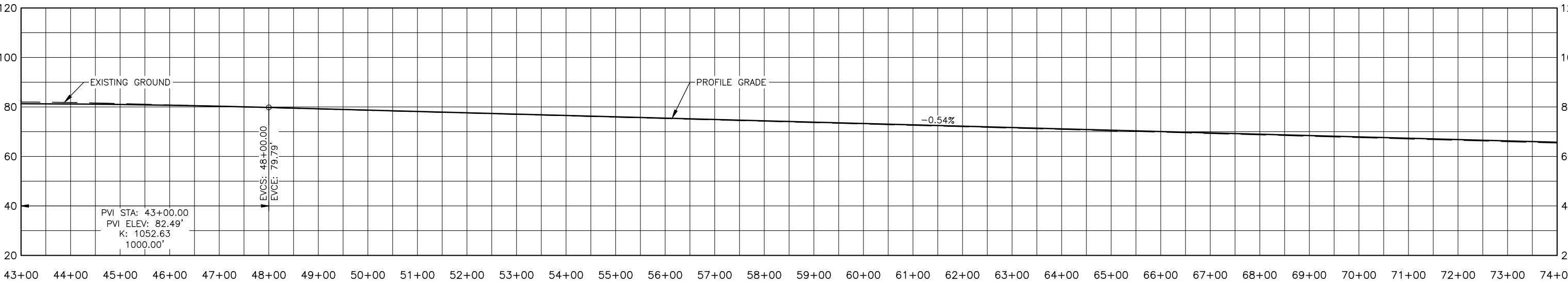
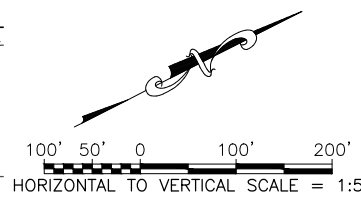
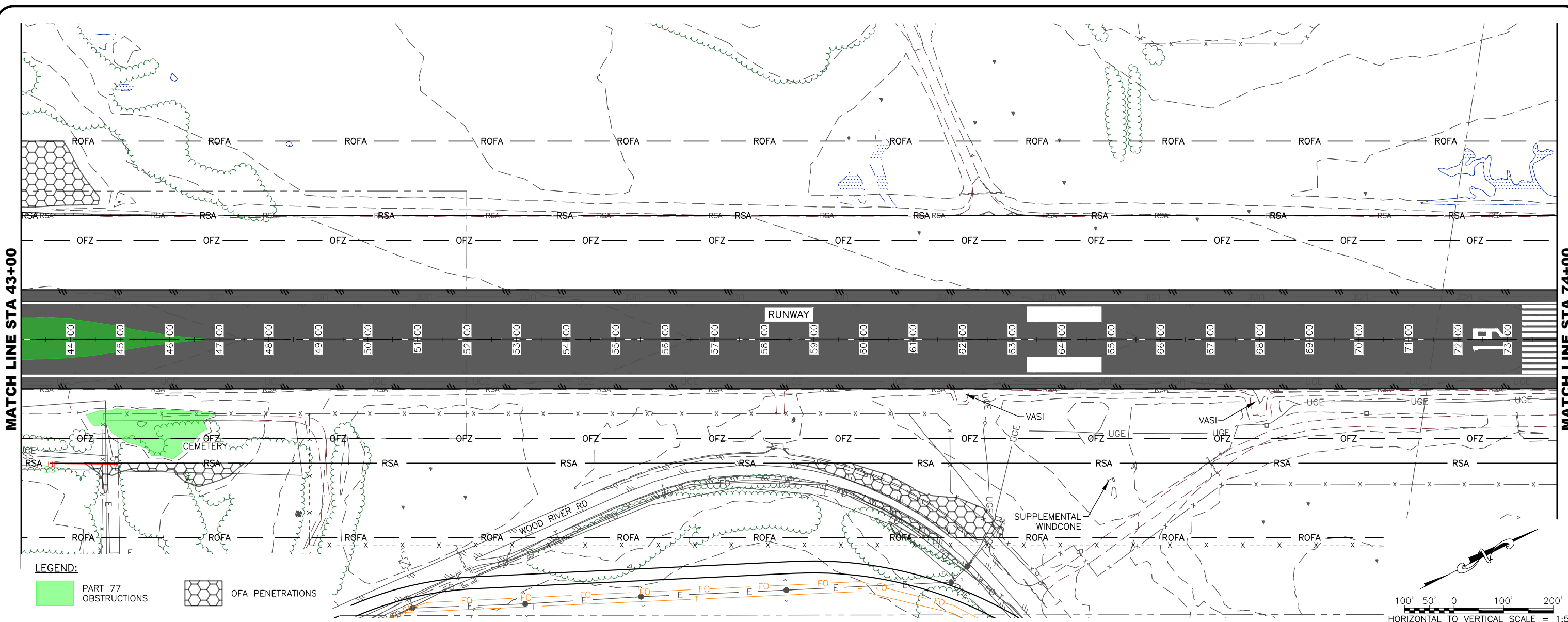

- IMPACTS:**
1. CONSTRUCT EMBANKMENT FOR RSA ON EAST SIDE.
  2. RELOCATE SUPPLEMENTAL WIND CONE.
  3. PART 77 OBSTRUCTION REMOVAL.

4. REALIGN WOOD RIVER RD AND ADJACENT FIBER OPTICE AND TELEPHONE OUTSIDE OF ROFA.
5. ADJUST AIRPORT PERIMETER FENCING.
6. ADJUST AIRPORT MAINTENANCE ROADS.
7. REPLACE AIRPORT LIGHTING SYSTEM.

PLANS DEVELOPED BY: R&M CONSULTANTS, INC. 9101 VANGUARD DR. ANCHORAGE, AK 99507 (907) 522-1707 CERT. OF AUTH. NO. AECC111		
BY	DATE	REVISION

**STATE OF ALASKA**  
**DEPARTMENT OF TRANSPORTATION**  
**AND PUBLIC FACILITIES**  
 4111 AVIATION AVE., ANCHORAGE ALASKA 99502  
 PHONE (907) 269-0590

**DILLINGHAM AIRPORT**  
 DILLINGHAM, ALASKA  
 AIRPORT MASTER PLAN  
 PROJECT No. CFAPT00353  
 AIP No. 3-02-0078-017-2018  
 ALTERNATIVE No. 3  
 NO GRADE CORRECTION

DATE: 3/22/2022  
 SHEET: 3 OF 4

Date Revised: 3/22/2022, 11:14 AM  
 Layout Name: 4  
 File Path and Name: Z:\project\2820.01 DOT\_C DIG AMP Update\Civil\ACAD\Alternatives\Alternative 3\00353-DLG-Alternative\_3.dwg  
 Designed By: MM  
 Drawn By: AWA/RLC  
 Checked By: CJB

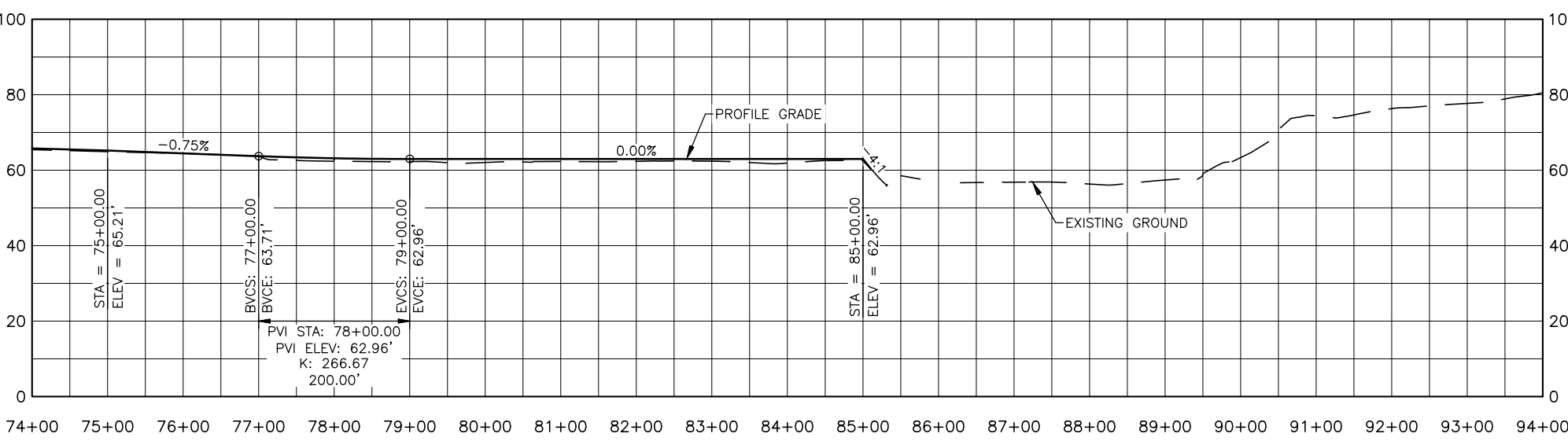
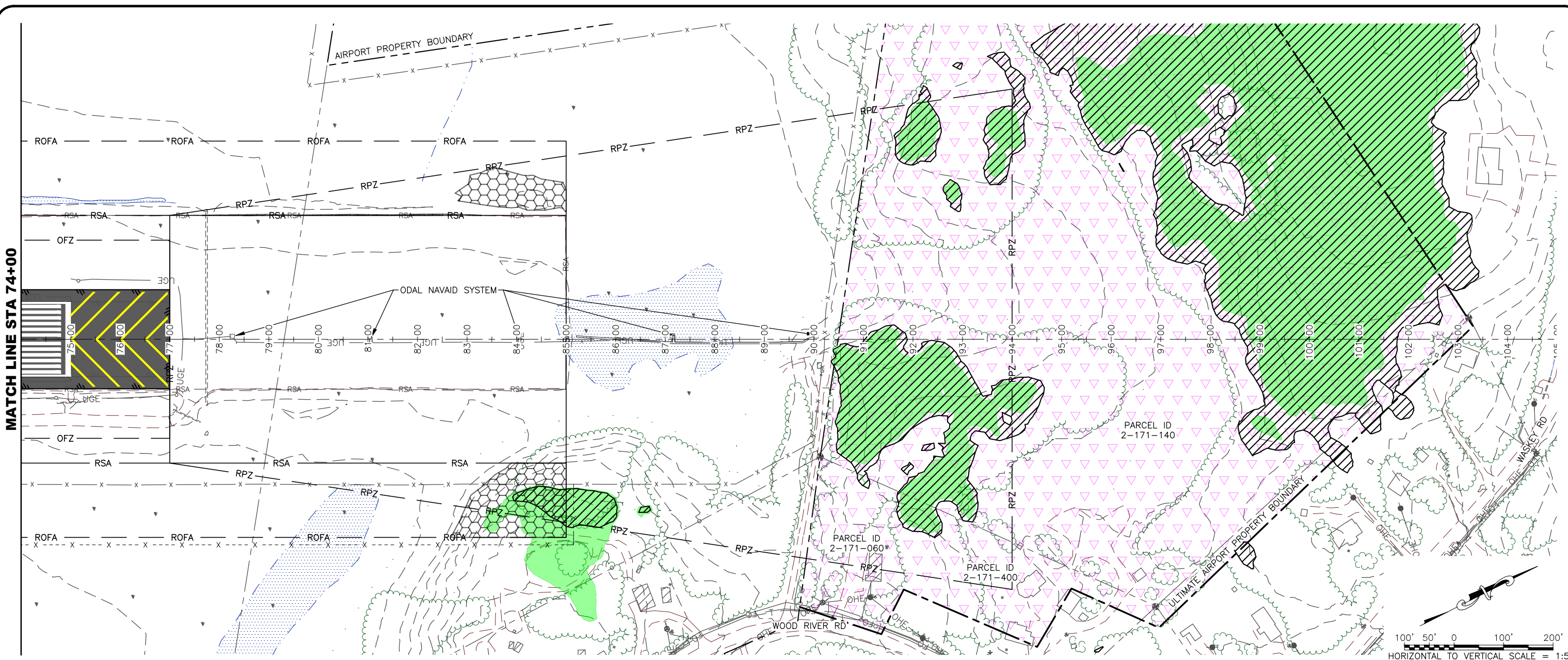

- LEGEND:**
- PART 77 TREE OBSTRUCTIONS
  - DEPARTURE SURFACE TREE OBSTRUCTIONS
  - OFA PENETRATIONS
  - PROPERTY ACQUISITION
- IMPACTS:**
1. CONSTRUCT EMBANKMENT FOR RSA ON EAST SIDE.
  2. OBSTRUCTION REMOVAL.
  3. PROPERTY ACQUISITION FOR CONTROL OF RPZ.
  4. ADJUST AIRPORT PERIMETER FENCING.
  5. ADJUST AIRPORT MAINTENANCE ROADS.
  6. REPLACE AIRPORT LIGHTING SYSTEM.
  7. EXTEND 42" DIA. RUNWAY CROSS CULVERT 150'.

PLANS DEVELOPED BY: R&M CONSULTANTS, INC. 9101 VANGUARD DR. ANCHORAGE, AK 99507 (907) 522-1707 CERT. OF AUTH. NO. AECC111		
BY	DATE	REVISION

**STATE OF ALASKA**  
**DEPARTMENT OF TRANSPORTATION**  
**AND PUBLIC FACILITIES**  
 4111 AVIATION AVE., ANCHORAGE ALASKA 99502  
 PHONE (907) 269-0590

**DILLINGHAM AIRPORT**  
 DILLINGHAM, ALASKA  
 AIRPORT MASTER PLAN  
 PROJECT No. CFAPT00353  
 AIP No. 3-02-0078-017-2018  
 ALTERNATIVE No. 3  
 NO GRADE CORRECTION

DATE:  
3/22/2022  
 SHEET:  
4 OF 4

# APPENDIX B

Cost Estimates

**Engineer's Estimate Summary**  
**State of Alaska - Department of Transportation and Public Facilities**  
**Central Region**  
**Dillingham Airport Master Plan**  
**Project No. CFAPT00353 / Federal No. AIP 3-02-0078-017-2018**  
**Alternative No. 1 - Base Estimate**

<i>Item No.</i>	<i>Pay Item</i>	<i>Pay Unit</i>	<i>Quantity</i>	<i>Unit Price</i>	<i>Amount</i>
D701.010.0042	CS PIPE, 42-INCH	LINEAR FOOT	400	\$ 450.00	\$ 180,000.00
F162.010.0008	8-FEET CHAIN-LINK FENCE	LINEAR FOOT	3,689	\$ 100.00	\$ 368,880.00
F170.010.0000	STEEL BOLLARDS	EACH	12	\$ 1,300.00	\$ 15,600.00
F171.020.0000	RELOCATE POWER GATE OPERATOR SYSTEM	LUMP SUM	All Req'd	\$ 100,000.00	\$ 100,000.00
G100.010.0000	MOBILIZATION AND DEMOBILIZATION	LUMP SUM	All Req'd	\$ 4,000,000.00	\$ 4,000,000.00
G115.010.0000	WORKERS MEALS AND LODGING, OR PER DIEM	LUMP SUM	All Req'd	\$ 1,000,000.00	\$ 1,000,000.00
G130.010.0000	FIELD OFFICE	LUMP SUM	All Req'd	\$ 70,000.00	\$ 70,000.00
G130.020.0000	FIELD LABORATORY	LUMP SUM	All Req'd	\$ 40,000.00	\$ 40,000.00
G130.060.0000	NUCLEAR TESTING EQUIPMENT STORAGE SHED	EACH	1	\$ 8,500.00	\$ 8,500.00
G130.110.0000	FIELD COMMUNICATIONS	CONTINGENT SUM	All Req'd	\$ 20,000.00	\$ 20,000.00
G131.010.0000	ENGINEERING TRANSPORTATION (TRUCK)	EACH	3	\$ 45,000.00	\$ 135,000.00
G135.010.0000	CONSTRUCTION SURVEYING BY THE CONTRACTOR	LUMP SUM	All Req'd	\$ 250,000.00	\$ 250,000.00
G300.010.0000	CPM SCHEDULING	LUMP SUM	All Req'd	\$ 10,000.00	\$ 10,000.00
G700.010.0000	AIRPORT FLAGGER	CONTINGENT SUM	All Req'd	\$ 75,000.00	\$ 75,000.00
G700.040.0000	TRAFFIC CONTROL FOR AIRPORTS	CONTINGENT SUM	All Req'd	\$ 50,000.00	\$ 50,000.00
L100.0X0.0000	AIRPORT LIGHTING	LUMP SUM	All Req'd	\$ 1,421,940.00	\$ 1,421,940.00
L100.0Y0.0000	APPROACH LIGHTING & NAVIGATIONAL AIDS	LUMP SUM	All Req'd	\$ 1,278,690.00	\$ 1,278,690.00
O100.0X0.0000	OBSTRUCTION REMOVAL & CLEARING	LUMP SUM	All Req'd	\$ 950,000.00	\$ 950,000.00
P152.010.0000	UNCLASSIFIED EXCAVATION	CUBIC YARD	326,920	\$ 10.00	\$ 3,269,200.00
P154.020.0000	SUBBASE COURSE	TON	357,960	\$ 20.00	\$ 7,159,200.00
P160.010.0000	EXCAVATION OF PAVEMENT	SQUARE YARD	130,420	\$ 5.00	\$ 652,100.00
P209.020.0000	CRUSHED AGGREGATE BASE COURSE	TON	20,300	\$ 40.00	\$ 812,000.00
P299.020.0000	CRUSHED AGGREGATE SURFACE COURSE	TON	76,550	\$ 55.00	\$ 4,210,250.00
P318.020.0000	FOAMED ASPHALT STABILIZED BASE COURSE	SQUARE YARD	135,550	\$ 10.00	\$ 1,355,500.00
P318.040.0000	ASPHALT BINDER	TON	1,424	\$ 1,400.00	\$ 1,993,600.00
P318.050.0000	PORTLAND CEMENT	TON	854	\$ 700.00	\$ 597,800.00
P401.010.0030	HOT MIX ASPHALT TYPE II, CLASS A	TON	37,070	\$ 140.00	\$ 5,189,800.00

**Engineer's Estimate Summary**  
**State of Alaska - Department of Transportation and Public Facilities**  
**Central Region**  
**Dillingham Airport Master Plan**  
**Project No. CFAPT00353 / Federal No. AIP 3-02-0078-017-2018**  
**Alternative No. 1 - Base Estimate**

<i>Item No.</i>	<i>Pay Item</i>	<i>Pay Unit</i>	<i>Quantity</i>	<i>Unit Price</i>	<i>Amount</i>
P401.030.5240	ASPHALT BINDER, PG 52-40V	TON	2,039	\$ 1,400.00	\$ 2,854,600.00
P401.080.0000	HOT MIX ASPHALT PRICE ADJUSTMENT	CONTINGENT SUM	All Req'd	\$ 210,000.00	\$ 210,000.00
P401.090.0000	ASPHALT MATERIAL PRICE ADJUSTMENT	CONTINGENT SUM	All Req'd	\$ -	\$ -
P603.010.0010	TACK COAT, STE-1	TON	91	\$ 1,550.00	\$ 141,050.00
P620.010.0000	RUNWAY & TAXIWAY PAINTING	SQUARE FOOT	95,240	\$ 2.25	\$ 214,290.00
P620.075.0000	TEMPORARY RUNWAY & TAXIWAY PAINTING	SQUARE FOOT	117,050	\$ 2.00	\$ 234,100.00
P621.010.0000	SAW-CUT GROOVES	SQUARE YARD	106,667	\$ 1.75	\$ 186,667.25
P640.020.0000	SEGMENTED CIRCLE (PANEL-TYPE)	LUMP SUM	All Req'd	\$ 100,000.00	\$ 100,000.00
P641.010.0000	EROSION, SEDIMENT, AND POLLUTION CONTROL ADMINISTRATION	LUMP SUM	All Req'd	\$ 20,000.00	\$ 20,000.00
P641.050.0000	TEMPORARY EROSION, SEDIMENT, AND POLLUTION CONTROL BY DIRECTIVE	CONTINGENT SUM	All Req'd	\$ 350,000.00	\$ 350,000.00
P641.060.0000	WITHOLDING	CONTINGENT SUM	All Req'd	\$ -	\$ -
P641.070.0000	SWPPP MANAGER	LUMP SUM	All Req'd	\$ 125,000.00	\$ 125,000.00
P670.010.0000	HAZARD MARKER BARRIER, PLASTIC	EACH	84	\$ 460.00	\$ 38,640.00
P671.010.0000	RUNWAY CLOSURE MARKER, VINYL MESH	EACH	7	\$ 1,900.00	\$ 13,300.00
P671.020.0000	RUNWAY CLOSURE MARKER, ILLUMINATED	EACH	2	\$ 35,000.00	\$ 70,000.00
P671.040.0000	TAXIWAY CLOSURE MARKER, VINYL	EACH	4	\$ 1,900.00	\$ 7,600.00
R100.0X0.0000	RIGHT-OF-WAY ACQUISITION	LUMP SUM	All Req'd	\$ 5,804,000.00	\$ 5,804,000.00
T901.010.0000	SEEDING	ACRE	15.0	\$ 7,000.00	\$ 105,000.00
T905.010.0020	TOPSOILING, CLASS B	SQUARE YARD	58,080	\$ 3.50	\$ 203,280.00
T908.010.0000	MULCHING	SQUARE YARD	58,080	\$ 1.50	\$ 87,120.00
U100.0X0.0000	UTILITY RELOCATION	LUMP SUM	All Req'd	\$ 1,525,000.00	\$ 1,525,000.00
Z100.0X0.0000	ROAD RE-ALIGNMENT	LUMP SUM	All Req'd	\$ 503,000.00	\$ 503,000.00

Total Basic Bid: \$ 48,005,707.25

Construction Engineering @ 20%: \$ 9,601,141.45

ICAP @ 5.88%: \$ 3,387,282.70

Project Total: \$ 60,994,131.40

**Engineer's Estimate Summary**  
**State of Alaska - Department of Transportation and Public Facilities**  
**Central Region**  
**Dillingham Airport Master Plan**  
**Project No. CFAPT00353 / Federal No. AIP 3-02-0078-017-2018**  
**Alternative No. 2 - Base Estimate**

<i>Item No.</i>	<i>Pay Item</i>	<i>Pay Unit</i>	<i>Quantity</i>	<i>Unit Price</i>	<i>Amount</i>
D701.010.0042	CS PIPE, 42-INCH	LINEAR FOOT	400	\$ 450.00	\$ 180,000.00
F162.010.0008	8-FEET CHAIN-LINK FENCE	LINEAR FOOT	3,689	\$ 100.00	\$ 368,880.00
F170.010.0000	STEEL BOLLARDS	EACH	12	\$ 1,300.00	\$ 15,600.00
F171.020.0000	RELOCATE POWER GATE OPERATOR SYSTEM	LUMP SUM	All Req'd	\$ 100,000.00	\$ 100,000.00
G100.010.0000	MOBILIZATION AND DEMOBILIZATION	LUMP SUM	All Req'd	\$ 4,000,000.00	\$ 4,000,000.00
G115.010.0000	WORKERS MEALS AND LODGING, OR PER DIEM	LUMP SUM	All Req'd	\$ 1,000,000.00	\$ 1,000,000.00
G130.010.0000	FIELD OFFICE	LUMP SUM	All Req'd	\$ 70,000.00	\$ 70,000.00
G130.020.0000	FIELD LABORATORY	LUMP SUM	All Req'd	\$ 40,000.00	\$ 40,000.00
G130.060.0000	NUCLEAR TESTING EQUIPMENT STORAGE SHED	EACH	1	\$ 8,500.00	\$ 8,500.00
G130.110.0000	FIELD COMMUNICATIONS	CONTINGENT SUM	All Req'd	\$ 20,000.00	\$ 20,000.00
G131.010.0000	ENGINEERING TRANSPORTATION (TRUCK)	EACH	3	\$ 45,000.00	\$ 135,000.00
G135.010.0000	CONSTRUCTION SURVEYING BY THE CONTRACTOR	LUMP SUM	All Req'd	\$ 250,000.00	\$ 250,000.00
G300.010.0000	CPM SCHEDULING	LUMP SUM	All Req'd	\$ 10,000.00	\$ 10,000.00
G700.010.0000	AIRPORT FLAGGER	CONTINGENT SUM	All Req'd	\$ 75,000.00	\$ 75,000.00
G700.040.0000	TRAFFIC CONTROL FOR AIRPORTS	CONTINGENT SUM	All Req'd	\$ 50,000.00	\$ 50,000.00
L100.0X0.0000	AIRPORT LIGHTING	LUMP SUM	All Req'd	\$ 1,421,940.00	\$ 1,421,940.00
L100.0Y0.0000	APPROACH LIGHTING & NAVIGATIONAL AIDS	LUMP SUM	All Req'd	\$ 1,278,690.00	\$ 1,278,690.00
O100.0X0.0000	OBSTRUCTION REMOVAL & CLEARING	LUMP SUM	All Req'd	\$ 1,116,000.00	\$ 1,116,000.00
P152.010.0000	UNCLASSIFIED EXCAVATION	CUBIC YARD	337,180	\$ 10.00	\$ 3,371,800.00
P152.200.0000	BORROW	TON	0	\$ 10.00	\$ -
P154.020.0000	SUBBASE COURSE	TON	355,780	\$ 20.00	\$ 7,115,600.00
P160.010.0000	EXCAVATION OF PAVEMENT	SQUARE YARD	124,670	\$ 5.00	\$ 623,350.00
P209.020.0000	CRUSHED AGGREGATE BASE COURSE	TON	19,116	\$ 40.00	\$ 764,637.60
P299.020.0000	CRUSHED AGGREGATE SURFACE COURSE	TON	78,940	\$ 55.00	\$ 4,341,706.38
P318.020.0000	FOAMED ASPHALT STABILIZED BASE COURSE	SQUARE YARD	128,000	\$ 10.00	\$ 1,280,000.00
P318.040.0000	ASPHALT BINDER	TON	1,365	\$ 1,400.00	\$ 1,911,000.00
P318.050.0000	PORTLAND CEMENT	TON	819	\$ 700.00	\$ 573,300.00
P401.010.0030	HOT MIX ASPHALT TYPE II, CLASS A	TON	34,130	\$ 140.00	\$ 4,778,200.00
P401.030.5240	ASPHALT BINDER, PG 52-40V	TON	1,878	\$ 1,400.00	\$ 2,629,200.00
P401.080.0000	HOT MIX ASPHALT PRICE ADJUSTMENT	CONTINGENT SUM	All Req'd	\$ 210,000.00	\$ 210,000.00
P401.090.0000	ASPHALT MATERIAL PRICE ADJUSTMENT	CONTINGENT SUM	All Req'd	\$ -	\$ -

**Engineer's Estimate Summary**  
**State of Alaska - Department of Transportation and Public Facilities**  
**Central Region**  
**Dillingham Airport Master Plan**  
**Project No. CFAPT00353 / Federal No. AIP 3-02-0078-017-2018**  
**Alternative No. 2 - Base Estimate**

<i>Item No.</i>	<i>Pay Item</i>	<i>Pay Unit</i>	<i>Quantity</i>	<i>Unit Price</i>	<i>Amount</i>
P603.010.0010	TACK COAT, STE-1	TON	92	\$ 1,550.00	\$ 142,600.00
P620.010.0000	RUNWAY & TAXIWAY PAINTING	SQUARE FOOT	87,150	\$ 2.25	\$ 196,087.50
P620.075.0000	TEMPORARY RUNWAY & TAXIWAY PAINTING	SQUARE FOOT	117,050	\$ 2.00	\$ 234,100.00
P621.010.0000	SAW-CUT GROOVES	SQUARE YARD	100,000	\$ 1.75	\$ 175,000.00
P640.020.0000	SEGMENTED CIRCLE (PANEL-TYPE)	LUMP SUM	All Req'd	\$ 100,000.00	\$ 100,000.00
P641.010.0000	EROSION, SEDIMENT, AND POLLUTION CONTROL ADMINISTRATION	LUMP SUM	All Req'd	\$ 20,000.00	\$ 20,000.00
P641.050.0000	TEMPORARY EROSION, SEDIMENT, AND POLLUTION CONTROL BY DIRECTIVE	CONTINGENT SUM	All Req'd	\$ 350,000.00	\$ 350,000.00
P641.060.0000	WITHHOLDING	CONTINGENT SUM	All Req'd	\$ -	\$ -
P641.070.0000	SWPPP MANAGER	LUMP SUM	All Req'd	\$ 125,000.00	\$ 125,000.00
P670.010.0000	HAZARD MARKER BARRIER, PLASTIC	EACH	84	\$ 460.00	\$ 38,640.00
P671.010.0000	RUNWAY CLOSURE MARKER, VINYL MESH	EACH	7	\$ 1,900.00	\$ 13,300.00
P671.020.0000	RUNWAY CLOSURE MARKER, ILLUMINATED	EACH	2	\$ 35,000.00	\$ 70,000.00
P671.040.0000	TAXIWAY CLOSURE MARKER, VINYL	EACH	4	\$ 1,900.00	\$ 7,600.00
R100.0X0.0000	RIGHT-OF-WAY ACQUISITION	LUMP SUM	All Req'd	\$ 5,804,000.00	\$ 5,804,000.00
T901.010.0000	SEEDING	ACRE	15	\$ 7,000.00	\$ 105,000.00
T905.010.0020	TOPSOILING, CLASS B	SQUARE YARD	58,080	\$ 3.50	\$ 203,280.00
T908.010.0000	MULCHING	SQUARE YARD	58,080	\$ 1.50	\$ 87,120.00
U100.0X0.0000	UTILITY ADJUSTMENTS OR RELOCATION	LUMP SUM	All Req'd	\$ 1,525,000.00	\$ 1,525,000.00
Z100.0X0.0000	ROAD REALIGNMENT	LUMP SUM	All Req'd	\$ 503,000.00	\$ 503,000.00

Total Basic Bid: \$ 47,438,131.48

Construction Engineering @ 20%: \$ 9,487,626.30

ICAP @ 5.88%: \$ 3,347,234.56

Project Total: \$ 60,272,992.33

**Engineer's Estimate Summary**  
**State of Alaska - Department of Transportation and Public Facilities**  
**Central Region**  
**Dillingham Airport Master Plan**  
**Project No. CFAPT00353 / Federal No. AIP 3-02-0078-017-2018**  
**Alternative No. 3 - Base Estimate**

<i>Item No.</i>	<i>Pay Item</i>	<i>Pay Unit</i>	<i>Quantity</i>	<i>Unit Price</i>	<i>Amount</i>
F162.010.0008	8-FEET CHAIN-LINK FENCE	LINEAR FOOT	5,266	\$ 100.00	\$ 526,560.00
F170.010.0000	STEEL BOLLARDS	EACH	12	\$ 1,300.00	\$ 15,600.00
F171.020.0000	RELOCATE POWER GATE OPERATOR SYSTEM	LUMP SUM	All Req'd	\$ 100,000.00	\$ 100,000.00
G100.010.0000	MOBILIZATION AND DEMOBILIZATION	LUMP SUM	All Req'd	\$ 4,000,000.00	\$ 4,000,000.00
G115.010.0000	WORKERS MEALS AND LODGING, OR PER DIEM	LUMP SUM	All Req'd	\$ 1,000,000.00	\$ 1,000,000.00
G130.010.0000	FIELD OFFICE	LUMP SUM	All Req'd	\$ 70,000.00	\$ 70,000.00
G130.020.0000	FIELD LABORATORY	LUMP SUM	All Req'd	\$ 40,000.00	\$ 40,000.00
G130.060.0000	NUCLEAR TESTING EQUIPMENT STORAGE SHED	EACH	1	\$ 8,500.00	\$ 8,500.00
G130.110.0000	FIELD COMMUNICATIONS	CONTINGENT SUM	All Req'd	\$ 20,000.00	\$ 20,000.00
G131.010.0000	ENGINEERING TRANSPORTATION (TRUCK)	EACH	3	\$ 45,000.00	\$ 135,000.00
G135.010.0000	CONSTRUCTION SURVEYING BY THE CONTRACTOR	LUMP SUM	All Req'd	\$ 250,000.00	\$ 250,000.00
G300.010.0000	CPM SCHEDULING	LUMP SUM	All Req'd	\$ 10,000.00	\$ 10,000.00
G700.010.0000	AIRPORT FLAGGER	CONTINGENT SUM	All Req'd	\$ 75,000.00	\$ 75,000.00
G700.040.0000	TRAFFIC CONTROL FOR AIRPORTS	CONTINGENT SUM	All Req'd	\$ 50,000.00	\$ 50,000.00
L100.0X0.0000	AIRPORT LIGHTING	LUMP SUM	All Req'd	\$ 1,395,300.00	\$ 1,395,300.00
L100.0Y0.0000	APPROACH LIGHTING & NAVIGATIONAL AIDS	LUMP SUM	All Req'd	\$ 314,220.00	\$ 314,220.00
O100.0X0.0000	OBSTRUCTION REMOVAL & CLEARING	LUMP SUM	All Req'd	\$ 938,000.00	\$ 938,000.00
P152.010.0000	UNCLASSIFIED EXCAVATION	CUBIC YARD	38,090	\$ 10.00	\$ 380,900.00
P152.200.0000	BORROW	TON	425,150	\$ 17.00	\$ 7,227,550.00
P160.010.0000	EXCAVATION OF PAVEMENT	SQUARE YARD	7,340	\$ 5.00	\$ 36,700.00
P299.020.0000	CRUSHED AGGREGATE SURFACE COURSE	TON	34,550	\$ 55.00	\$ 1,900,250.00
P620.010.0000	RUNWAY & TAXIWAY PAINTING	SQUARE FOOT	93,240	\$ 2.25	\$ 209,790.00
P640.020.0000	SEGMENTED CIRCLE (PANEL-TYPE)	LUMP SUM	All Req'd	\$ 100,000.00	\$ 100,000.00
P641.010.0000	EROSION, SEDIMENT, AND POLLUTION CONTROL ADMINISTRATION	LUMP SUM	All Req'd	\$ 20,000.00	\$ 20,000.00
P641.050.0000	TEMPORARY EROSION, SEDIMENT, AND POLLUTION CONTROL BY DIRECTIVE	CONTINGENT SUM	All Req'd	\$ 250,000.00	\$ 250,000.00
P641.060.0000	WITHOLDING	CONTINGENT SUM	All Req'd	\$ -	\$ -
P641.070.0000	SWPPP MANAGER	LUMP SUM	All Req'd	\$ 125,000.00	\$ 125,000.00
P671.020.0000	RUNWAY CLOSURE MARKER, ILLUMINATED	EACH	2	\$ 35,000.00	\$ 70,000.00
R100.0X0.0000	RIGHT-OF-WAY ACQUISITION	LUMP SUM	All Req'd	\$ 4,560,000.00	\$ 4,560,000.00
T901.010.0000	SEEDING	ACRE	17.0	\$ 7,000.00	\$ 119,000.00
T905.010.0020	TOPSOILING, CLASS B	SQUARE YARD	58,080	\$ 3.50	\$ 203,280.00



**Engineer's Estimate Summary**  
**State of Alaska - Department of Transportation and Public Facilities**  
**Central Region**  
**Dillingham Airport Master Plan**  
**Project No. CFAPT00353 / Federal No. AIP 3-02-0078-017-2018**  
**Alternative No. 3 - Base Estimate**

<i>Item No.</i>	<i>Pay Item</i>	<i>Pay Unit</i>	<i>Quantity</i>	<i>Unit Price</i>	<i>Amount</i>
T908.010.0000	MULCHING	SQUARE YARD	58,080	\$ 1.50	\$ 87,120.00
U100.0X0.0000	UTILITY RELOCATION	LUMP SUM	All Req'd	\$ 1,366,000.00	\$ 1,366,000.00
Z100.0X0.0000	ROAD RE-ALIGNMENT	LUMP SUM	All Req'd	\$ 503,000.00	\$ 503,000.00

Total Basic Bid: \$ 26,106,770.00

Construction Engineering @ 20%: \$ 5,221,354.00

ICAP @ 5.88%: \$ 1,842,093.69

Project Total: \$ 33,170,217.69

# **APPENDIX C**

## **Runway Length Determination**

Dillingham Airport

Airport Elevation (NAVD88) = 82<sup>5</sup>

Mean Max Temperature, Hottest Month = 62.5°F, July<sup>5</sup>

Existing Runway Length = 6,400'

Standard Day Temp = 59.0°F

ANC-DLG is approx. 330 miles. Use this value for Payload/Range charts. It's assumed most large aircraft are based out of ANC.

High Point = 81.99', Low Point = 64.89'; Runway gradient correction equals 10 x (81.99-64.89) = 171<sup>6</sup>

MTOW - Maximum takeoff weight

MLW - Maximum landing weight

TOW - Takeoff weight

Runway Length Determination per FAA AC 150/5325-4B Runway Length Requirements for Airport Design														
Aircraft <sup>1</sup>	Operations <sup>1</sup>	Cumulative Operations	AAC-ADG	TDG	MTOW (lbs) <sup>2,3</sup>	Operational TOW (lbs) <sup>4,7</sup>	MLW (lbs) <sup>3,4,10</sup>	FAR Takeoff Length Requirement (ft) <sup>4,7,8</sup>	- with Gradient Correction, Rounded (ft)	FAR Landing Length Requirement (ft) <sup>4,7,8,9</sup>	Jane's Operational TOW (lbs) <sup>10</sup>	Jane's Takeoff Length (ft) <sup>10</sup>	Jane's Landing Length (ft) <sup>10</sup>	
Boeing 737-200	15	15	C-III	3	115,500	112,500	103,000	8,750	9,000	5,400	109,000	6,650	4,500	
McDonnell Douglas DC9 MD82	199	214	C-III	4	149,500	137,000	130,000	6,200	6,400	5,500	-	7,450	4,920	
Boeing 737-400	88	302	C-III	3	150,000	129,000	124,000	6,000	6,200	6,000	150,000	8,740	5,050	
Boeing 737-700/700LR/Max 7	264	566	C-III	3	154,500	132,500	134,000	5,800	6,000	5,600	-	-	-	
McDonnell Douglas DC-9-41 (30)	78	644	C-III	2	114,000	107,500	100,000	5,800	6,000	5,500	121,000	6,850	4,720	
Boeing 737-300	175	819	C-III	3	139,500	117,500	114,000	5,500	5,700	5,350	138,500	7,500	4,700	
Lockheed L-382E	168	987	C-IV	2	164,000	-	130,000	-	-	3,100	155,000	3,580	2,750	
									Average:	6,550	Average:			7,438
									Rounded up to nearest 100':	6,600	Rounded up to nearest 100':			7,500
									Average weighted by operations:	6,110	Average weighted by operations:			7,564
									Rounded up to nearest 100':	6,200	Rounded up to nearest 100':			7,600
Runway Length Determination per FAA AC 150/5325-4B Runway Length Requirements for Airport Design for Potential Future Aircraft														
Boeing 737-800	0	0	C-III	3	174,200	151,000	146,300	5,900	6,100	6,700	-	-	-	
Boeing 737-900	0	0	C-III	3	174,200	151,000	146,300	6,900	7,100	6,700	-	-	-	
Boeing 737-900ER	0	0	C-III	3	187,700	162,500	157,300	6,900	7,100	6,400	-	-	-	

<sup>1</sup>R&M Consultants, Inc. DLG Master Plan Update - Aviation Forecast, 2021 from BTS T-100 Dataset, 2019 Operations

<sup>2</sup>FAA Aircraft Characteristics Database v2, 2018

<sup>3</sup>Everts Air - About - Our Fleet, 2021

<sup>4</sup>Boeing 737 Airplane Characteristics for Airport Planning Rev A, 2020

<sup>5</sup>DLG Airport Layout Plan, 2016

<sup>6</sup>CFAPT00104 DLG Runway Rehabilitation Construction Plans

<sup>7</sup>DC-9 Airplane Characteristics for Airport Planning, 1984

<sup>8</sup>MD-80 Series Airplane Characteristics for Airport Planning, 1990

<sup>9</sup>LM-100J Brochure, 2018

<sup>10</sup>Jane's All the World's Aircraft In Service, 2020

### 3.2 PAYLOAD/RANGE FOR LONG RANGE CRUISE

#### 3.2.1 Payload/Range for Long Range Cruise: Model 737-100 (JT8D-7 Engines)

NOTES:

- \* DOMESTIC RESERVES
- \* JT9D-7 ENGINES
- \* STANDARD DAY, ZERO WIND
- \* LRC AT 30,000 FEET (9,150 METERS)
- \* CONSULT WITH USING AIRLINE FOR SPECIFIC OPERATING PROCEDURE PRIOR TO FACILITY DESIGN

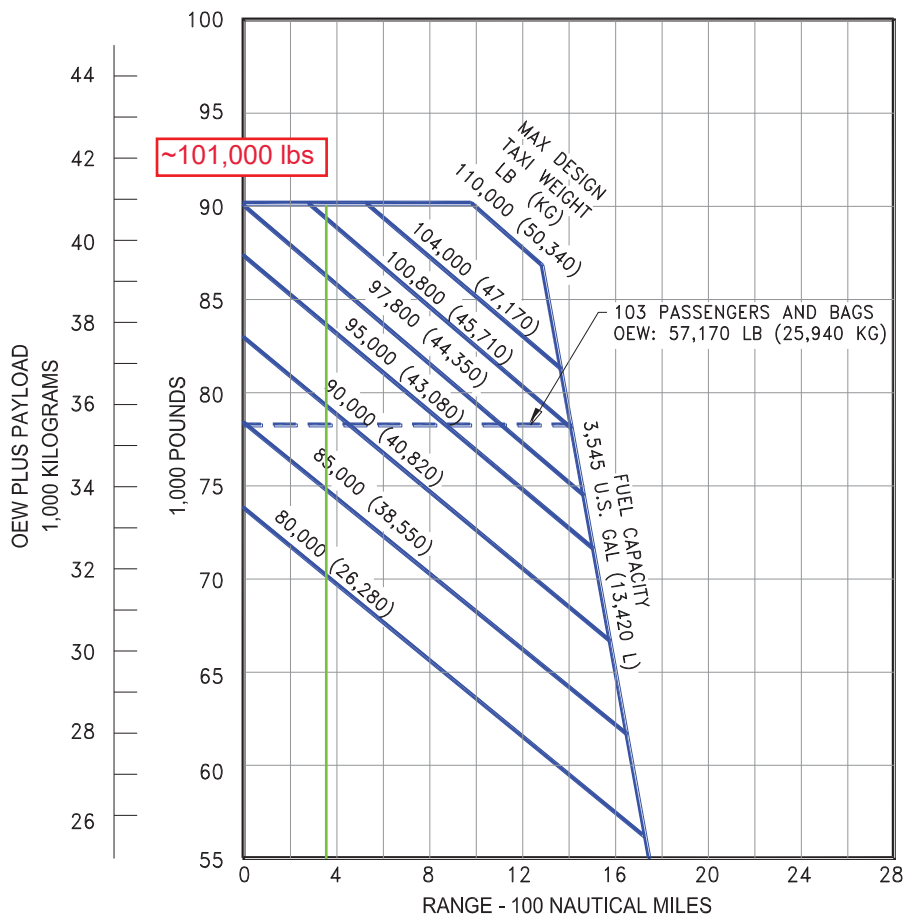

\* FOR TAKEOFF WEIGHT, SUBTRACT 500 LB (227 KG) FROM TAXI WEIGHT

Assume range at 350 miles for ANC - DLG

### 3.2.2 Payload/Range for Long Range Cruise: Model 737-200 (JT8D-9/9A Engines)

NOTES:

- \* DOMESTIC RESERVES
- \* JT9D-9/9A ENGINES
- \* STANDARD DAY, ZERO WIND
- \* LRC AT 30,000 FEET (9,150 METERS)
- \* CONSULT WITH USING AIRLINE FOR SPECIFIC OPERATING PROCEDURE PRIOR TO FACILITY DESIGN

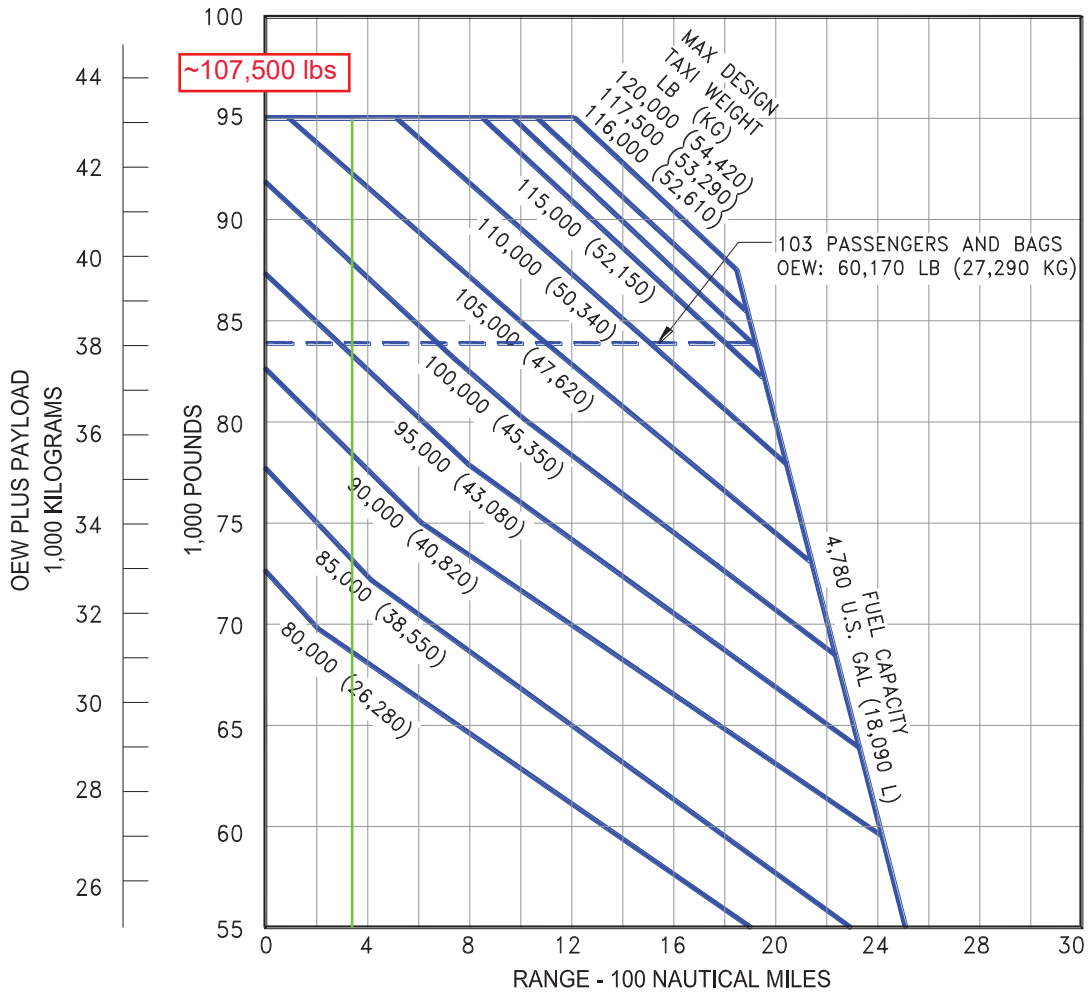

\* FOR TAKEOFF WEIGHT, SUBTRACT 500 LB (227 KG) FROM TAXI WEIGHT

### 3.2.3 Payload/Range for Long Range Cruise: Model 737-200 (JT8D-15/15A Engines)

NOTES:

- \* DOMESTIC RESERVES
- \* JT9D-15/15A ENGINES
- \* STANDARD DAY, ZERO WIND
- \* LRC AT 30,000 FEET (9,150 METERS)
- \* CONSULT WITH USING AIRLINE FOR SPECIFIC OPERATING PROCEDURE PRIOR TO FACILITY DESIGN

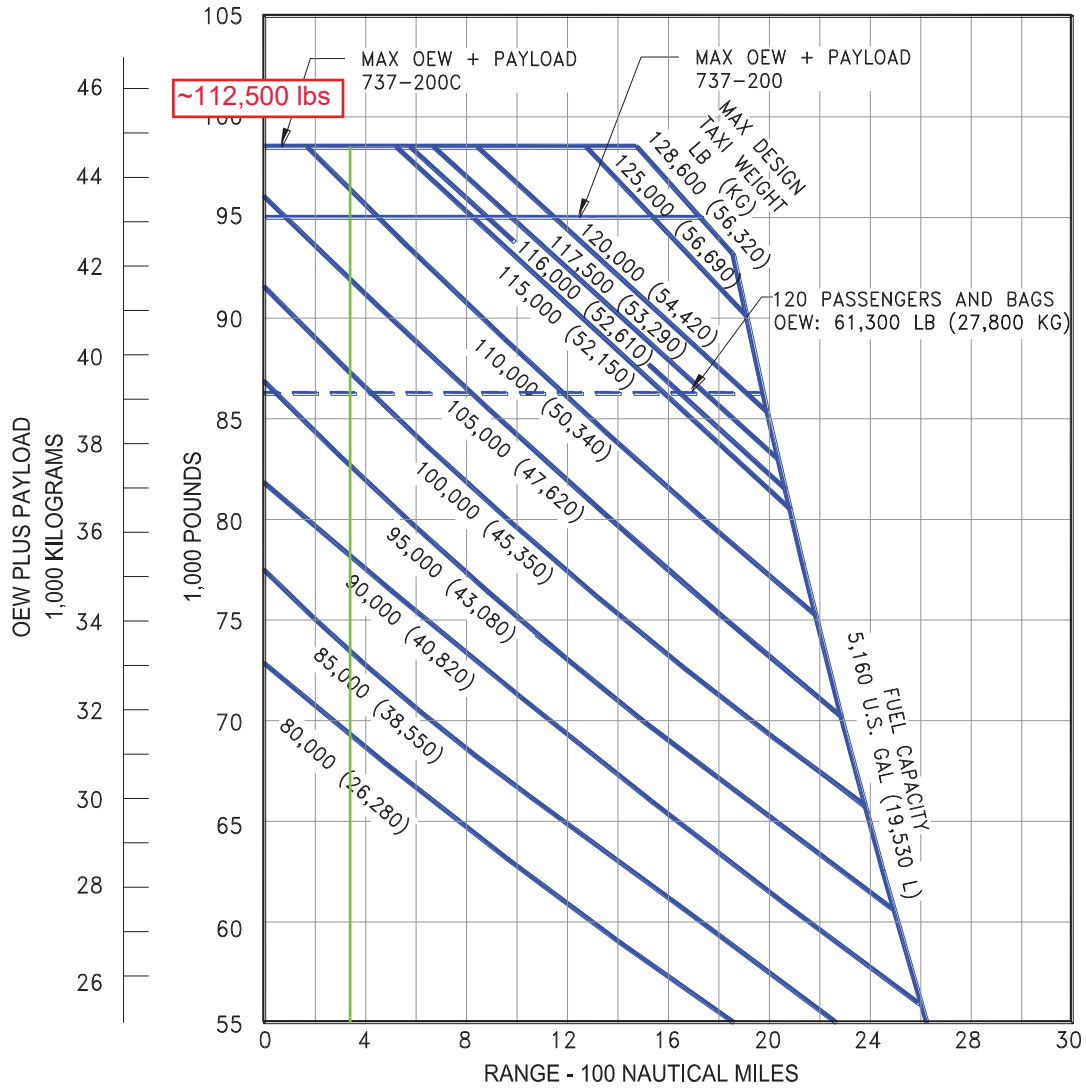

\* FOR TAKEOFF WEIGHT, SUBTRACT 500 LB (227 KG) FROM TAXI WEIGHT

### 3.2.6 Payload/Range for Long Range Cruise: Model 737-300

NOTES:

- \* DOMESTIC RESERVES
- \* CFM56-3B-1 OR CFM56-3B-2 ENGINES
- \* STANDARD DAY, ZERO WIND
- \* LRC AT 31,000/35,000 FEET
- \* CONSULT USING AIRLINE FOR SPECIFIC OPERATING PROCEDURE PRIOR TO FACILITY DESIGN

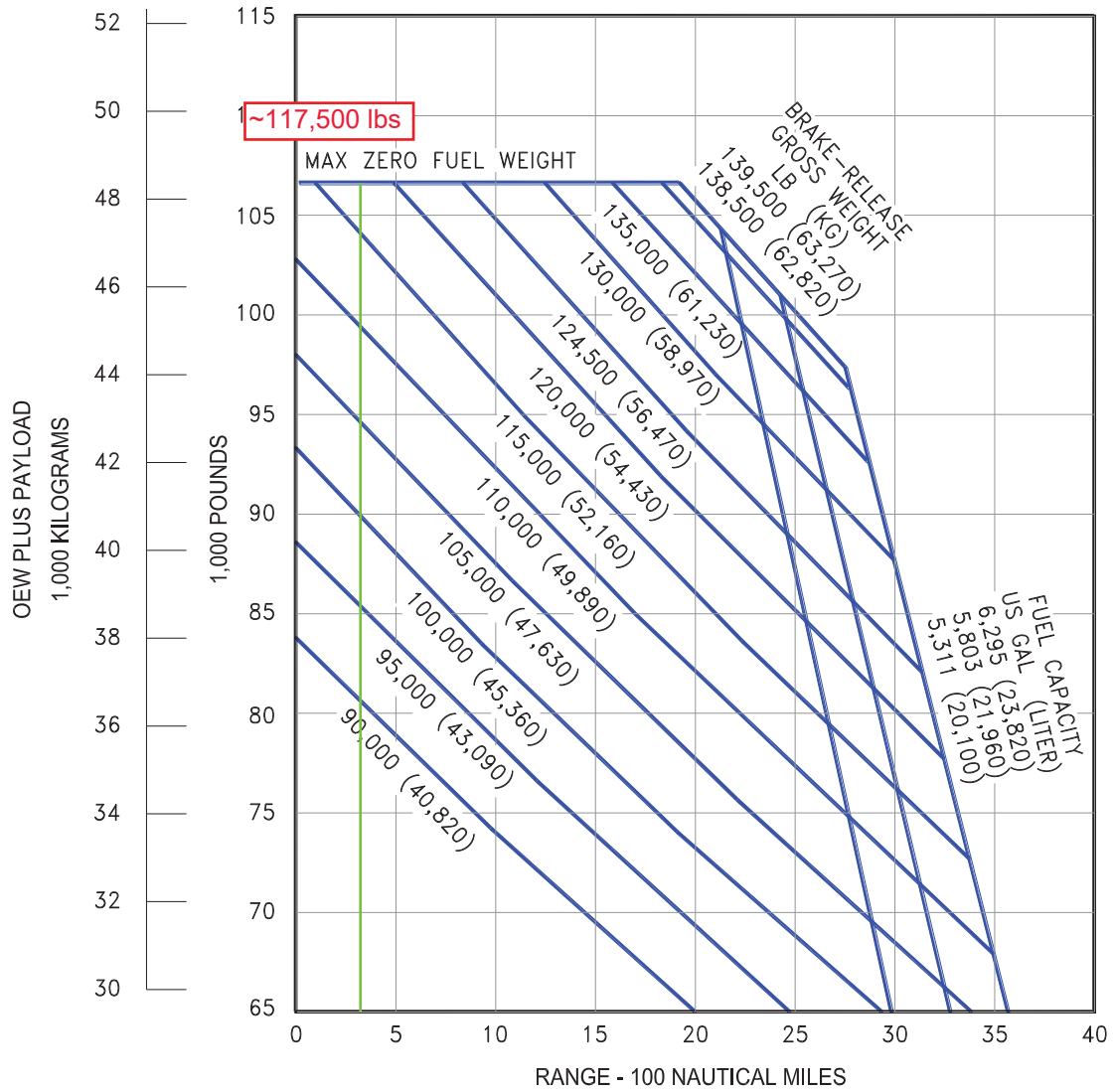

### 3.2.7 Payload/Range for Long Range Cruise: Model 737-400

NOTES:

- \* DOMESTIC RESERVES
- \* CFM56-3B-2 OR CFM56-3C-1 ENGINES
- \* STANDARD DAY, ZERO WIND
- \* LRC AT 31,000/35,000 FEET
- \* CONSULT USING AIRLINE FOR SPECIFIC OPERATING PROCEDURE PRIOR TO FACILITY DESIGN

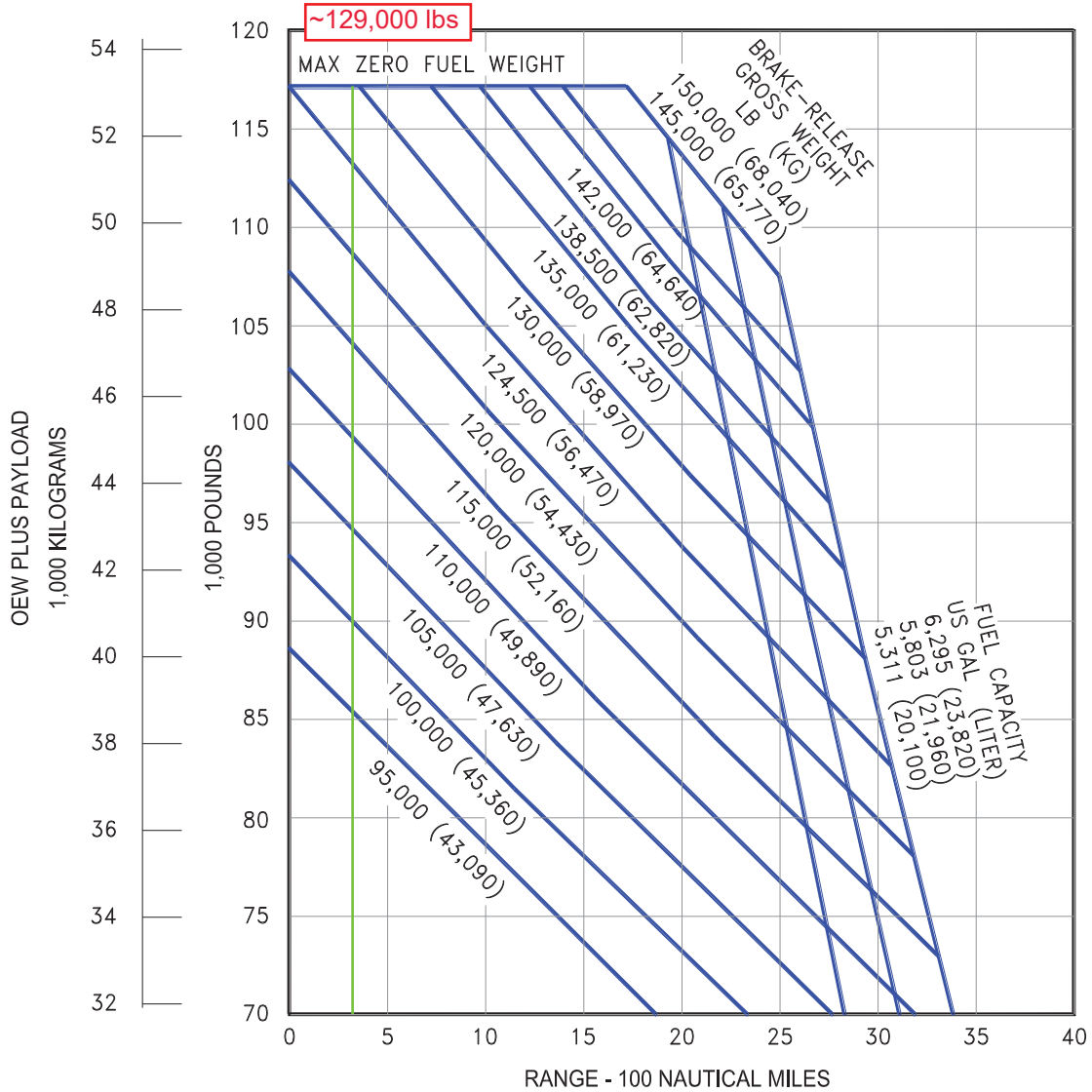



### 3.2.10 Payload/Range for Long Range Cruise: Model 737-700

DO NOT USE FOR DISPATCH

Payload/Range  
737-700/-700W (CFM56-7B Series)

- STANDARD DAY, ZERO WIND
- CRUISE MACH = LRC
- NORMAL POWER EXTRACTION AND AIR CONDITIONING BLEEDS
- TYPICAL MISSION RULES
- NON-WINGLET PERFORMANCE SHOWN. WINGLET AIRCRAFT WILL HAVE SLIGHTLY GREATER RANGE.
- CONSULT USING AIRLINE FOR SPECIFIC OPERATING PROCEDURE AND OEW PRIOR TO FACILITY DESIGN.

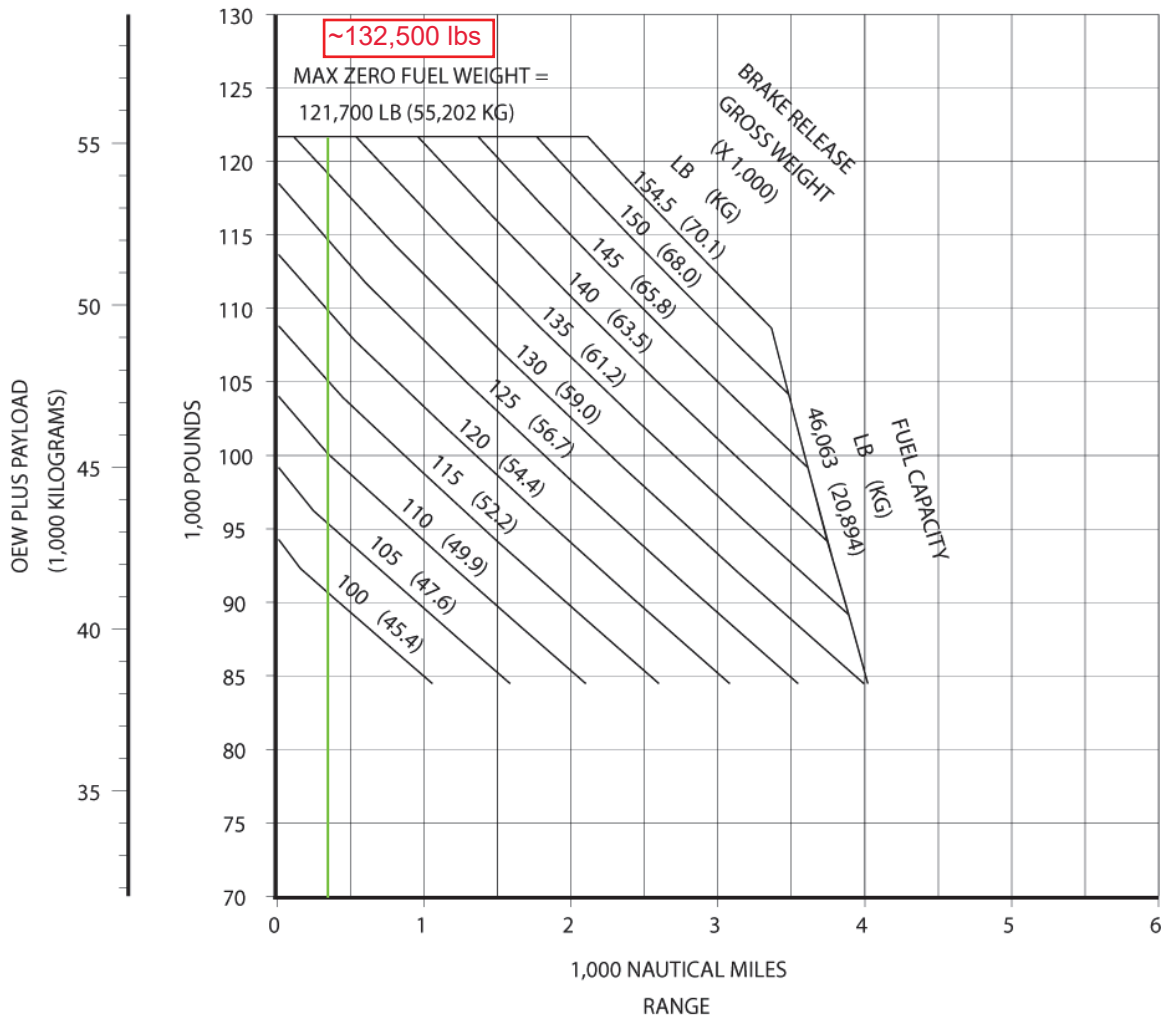

### 3.3.2 F.A.R. Takeoff Runway Length Requirements - Standard Day + 27°F (STD + 15°C): Model 737-100 (JT8D-7 Engines)

NOTES:

- \* NO ENGINE AIRBLEED FOR AIR CONDITIONING
- \* ZERO WIND, ZERO RUNWAY GRADIENT
- \* CONSULT USING AIRLINE FOR SPECIFIC OPERATING PROCEDURE PRIOR TO FACILITY DESIGN
- \* JT8D-7 ENGINES

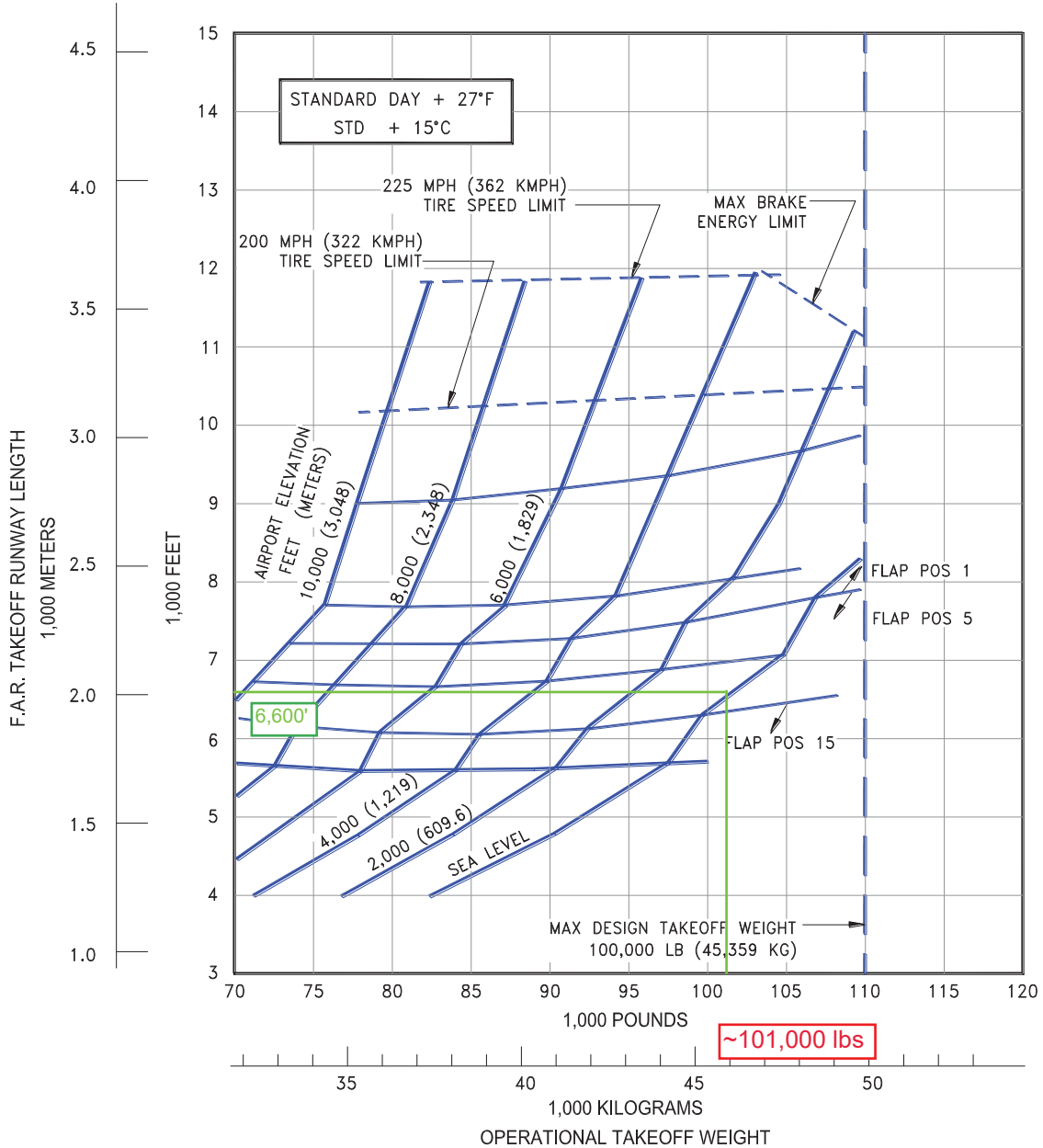

### 3.3.4 F.A.R. Takeoff Runway Length Requirements - Standard Day + 27°F (STD + 15°C): Model 737-200 (JT8D-9/9A Engines)

NOTES:

- \* NO ENGINE AIRBLEED FOR AIR CONDITIONING
- \* ZERO WIND, ZERO RUNWAY GRADIENT
- \* CONSULT USING AIRLINE FOR SPECIFIC OPERATING PROCEDURE PRIOR TO FACILITY DESIGN
- \* JT8D-9/9A ENGINES

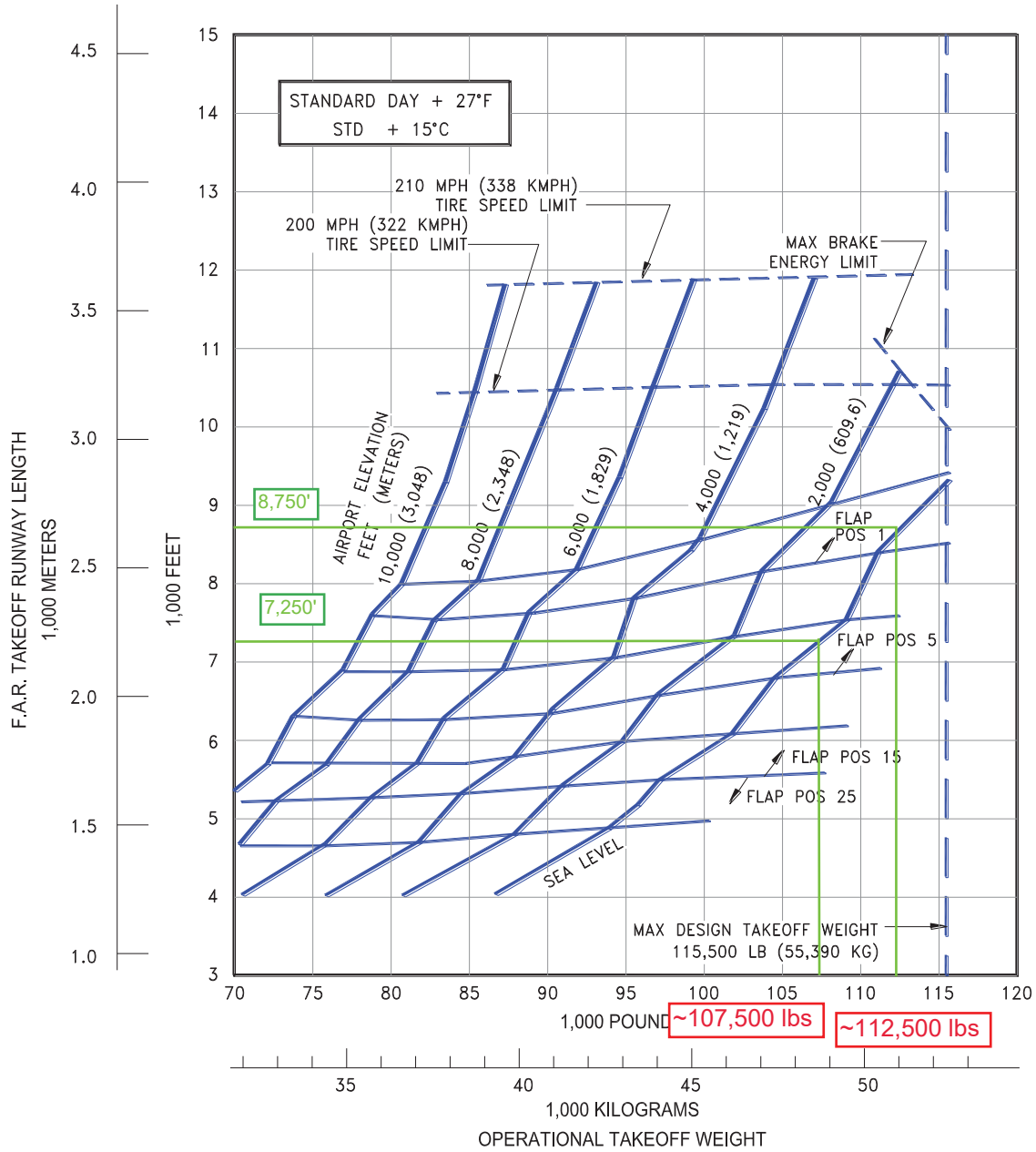

### 3.3.12 F.A.R. Takeoff Runway Length Requirements - Standard Day + 27°F (STD + 15°C): Model 737-300 (CFM56-3B1 Engines at 20,000 LB SLST)

NOTES:

- \* NO ENGINE AIRBLEED FOR AIR CONDITIONING
- \* ZERO WIND, ZERO RUNWAY GRADIENT
- \* CONSULT USING AIRLINE FOR SPECIFIC OPERATING PROCEDURE PRIOR TO FACILITY DESIGN
- \* CFM 56-3B1 ENGINES RATED AT 20,000 LB SLST

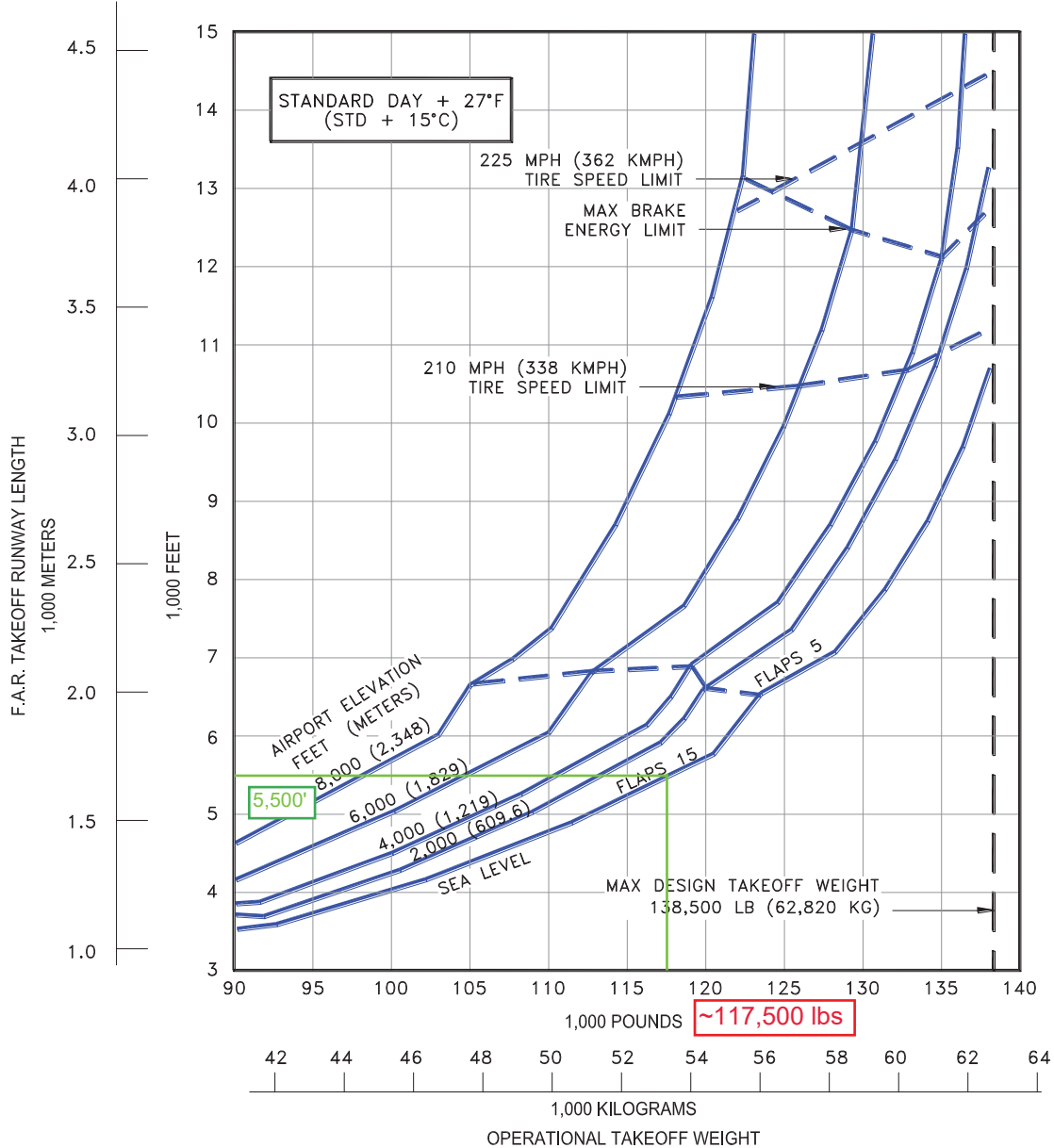

### 3.3.14 F.A.R. Takeoff Runway Length Requirements - Standard Day + 27°F (STD + 15°C): Model 737-300 (CFM56-3B-2 Engines at 22,000 LB SLST)

NOTES:

- \* NO ENGINE AIRBLEED FOR AIR CONDITIONING
- \* ZERO WIND, ZERO RUNWAY GRADIENT
- \* CONSULT USING AIRLINE FOR SPECIFIC OPERATING PROCEDURE PRIOR TO FACILITY DESIGN
- \* CFM 56-3B2 ENGINES RATED AT 22,000 LB SLST

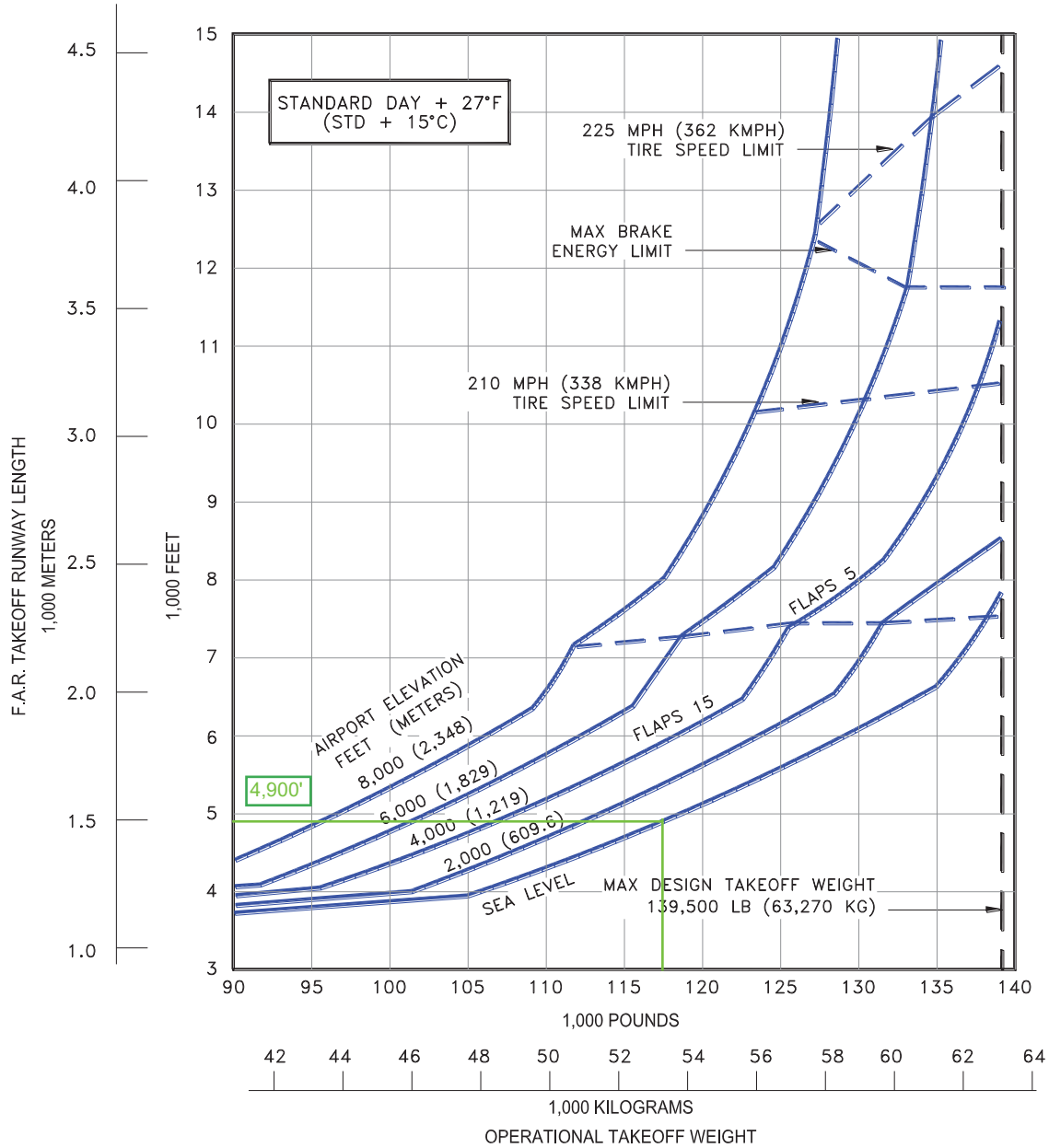

### 3.3.16 F.A.R. Takeoff Runway Length Requirements - Standard Day + 27°F (STD + 15°C): Model 737-400 (CFM56-3B-2 Engines at 22,000 LB SLST)

NOTES:

- \* NO ENGINE AIRBLEED FOR AIR CONDITIONING
- \* ZERO WIND, ZERO RUNWAY GRADIENT
- \* CONSULT USING AIRLINE FOR SPECIFIC OPERATING PROCEDURE PRIOR TO FACILITY DESIGN
- \* CFM 56-3B2 ENGINES RATED AT 22,000 LB SLST

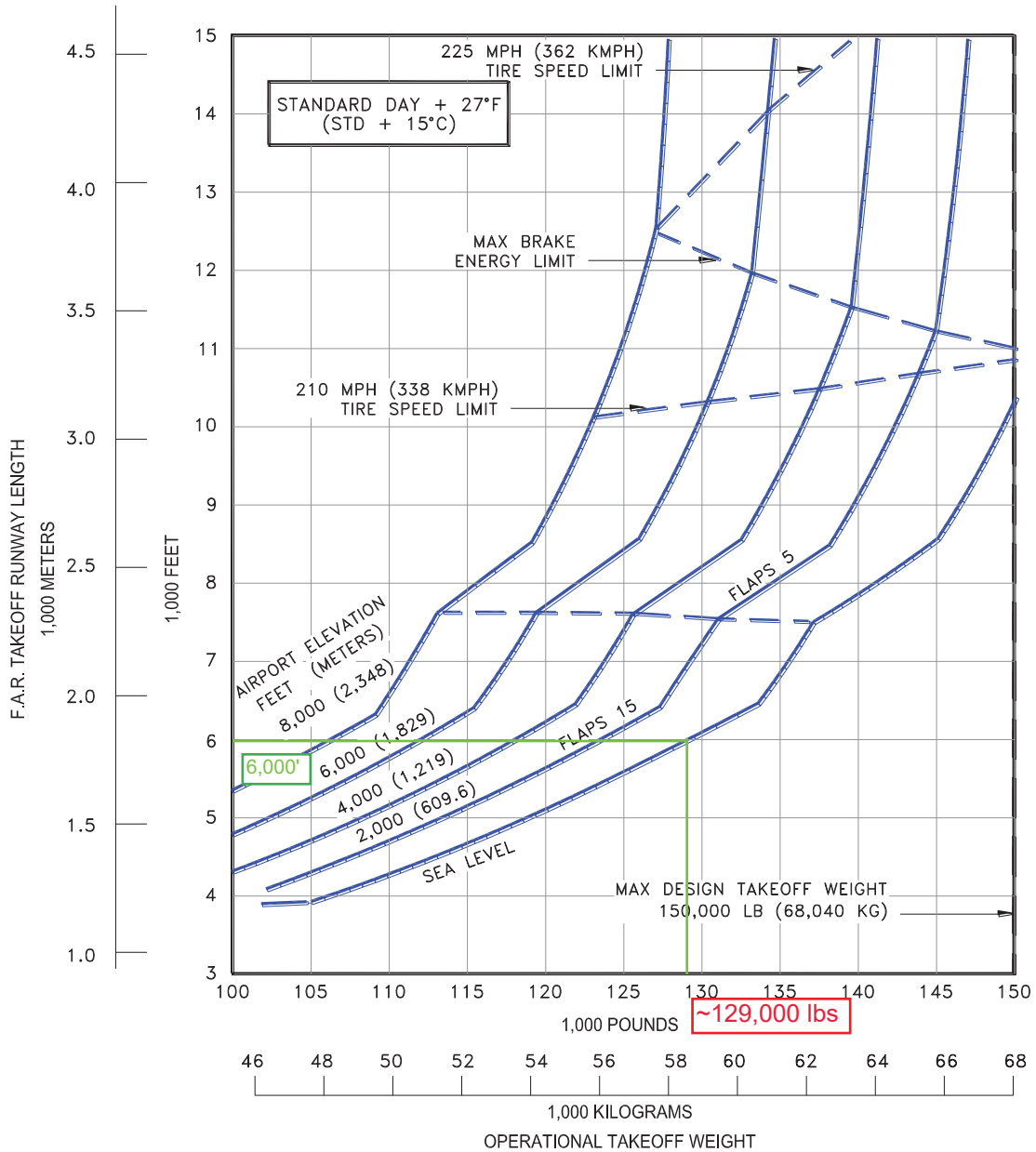

### 3.3.18 F.A.R. Takeoff Runway Length Requirements - Standard Day + 27°F (STD + 15°C): Model 737-400 (CFM56-3C1 Engines at 23,500 LB SLST)

NOTES:

- \* NO ENGINE AIRBLEED FOR AIR CONDITIONING
- \* ZERO WIND, ZERO RUNWAY GRADIENT
- \* CONSULT USING AIRLINE FOR SPECIFIC OPERATING PROCEDURE PRIOR TO FACILITY DESIGN
- \* CFM 56-3C1 ENGINES RATED AT 23,500 LB SLST

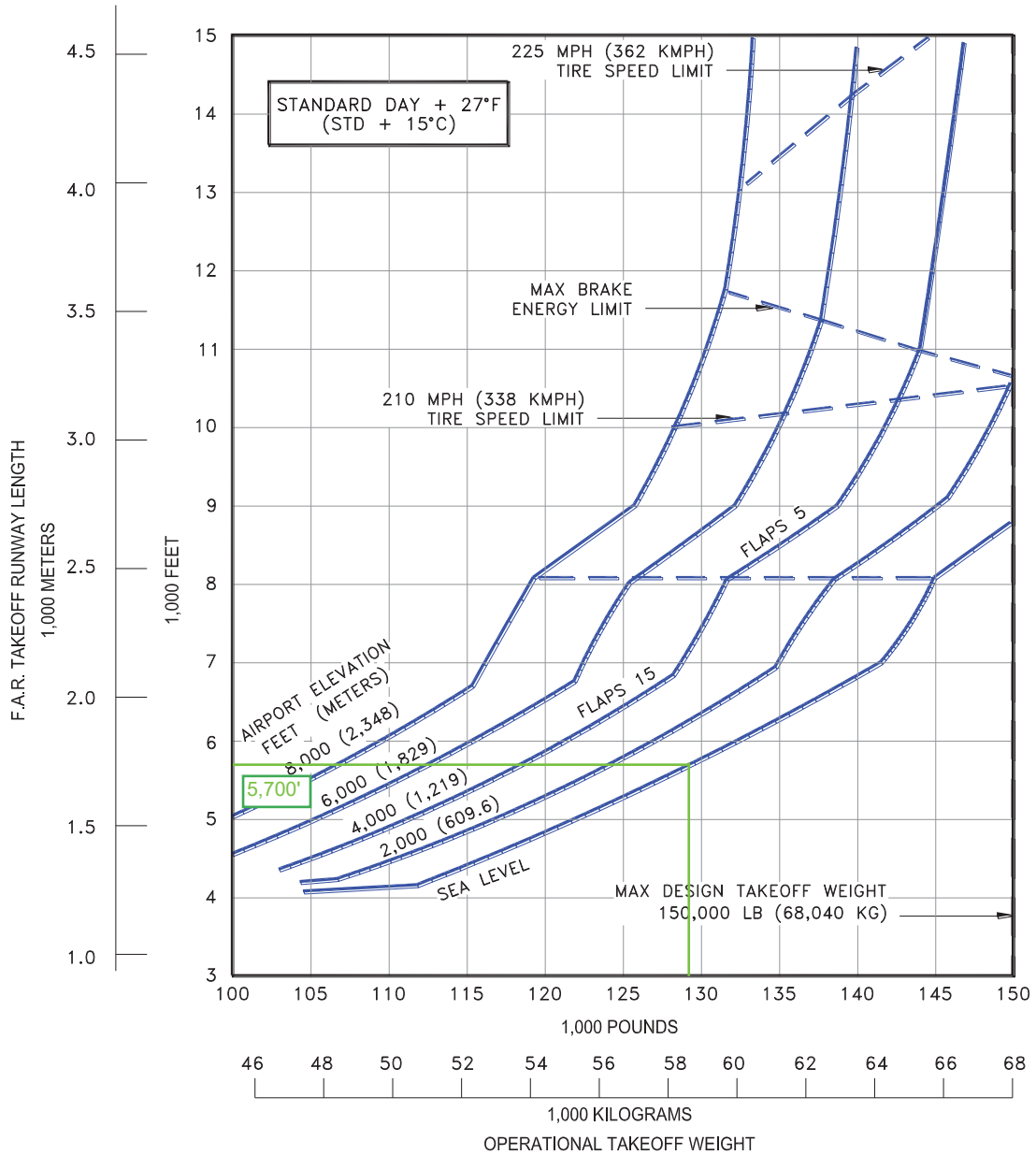

**3.3.32 F.A.R. Takeoff Runway Length Requirements - Standard Day + 27°F (STD + 15°C), Dry Runway: Model 737-700 (CFM56-7B20/-7B22/-7B24 Engines at 20,000 LB SLST)**

**DO NOT USE FOR DISPATCH**

**Takeoff Runway Length Requirements  
737-700/-700W (CFM56-7B20/-7B22/-7B24)**

- NON-WINGLET PERFORMANCE SHOWN. WINGLET AIRCRAFT WILL HAVE SLIGHTLY IMPROVED PERFORMANCE.
- CONSULT USING AIRLINE FOR SPECIFIC OPERATING PROCEDURE PRIOR TO FACILITY DESIGN.

DRY RUNWAY  
ZERO WIND  
ZERO RUNWAY GRADIENT  
AIR CONDITIONING OFF  
OPTIMUM FLAP SETTING

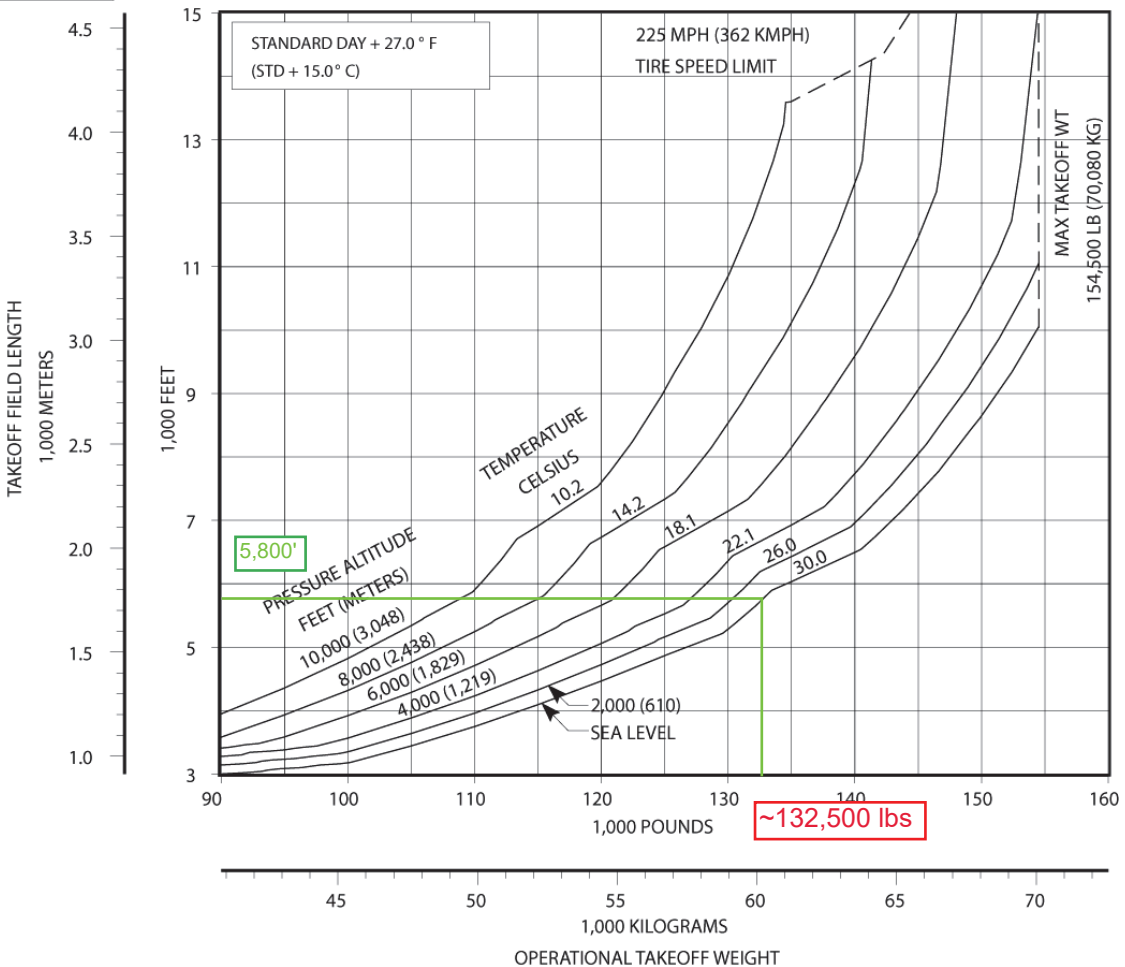



**3.3.36 F.A.R. Takeoff Runway Length Requirements - Standard Day, +27°F (STD + 15°C), Dry Runway: Model 737-700/-700W (CFM56-7B26 Engines at 26,000 LB SLST**

**DO NOT USE FOR DISPATCH**  
**Takeoff Runway Length Requirements**  
**737-700/-700W (CFM56-7B26)**

- NON-WINGLET PERFORMANCE SHOWN. WINGLET AIRCRAFT WILL HAVE SLIGHTLY IMPROVED PERFORMANCE.  
 - CONSULT USING AIRLINE FOR SPECIFIC OPERATING PROCEDURE PRIOR TO FACILITY DESIGN.

DRY RUNWAY  
 ZERO WIND  
 ZERO RUNWAY GRADIENT  
 AIR CONDITIONING OFF  
 OPTIMUM FLAP SETTING

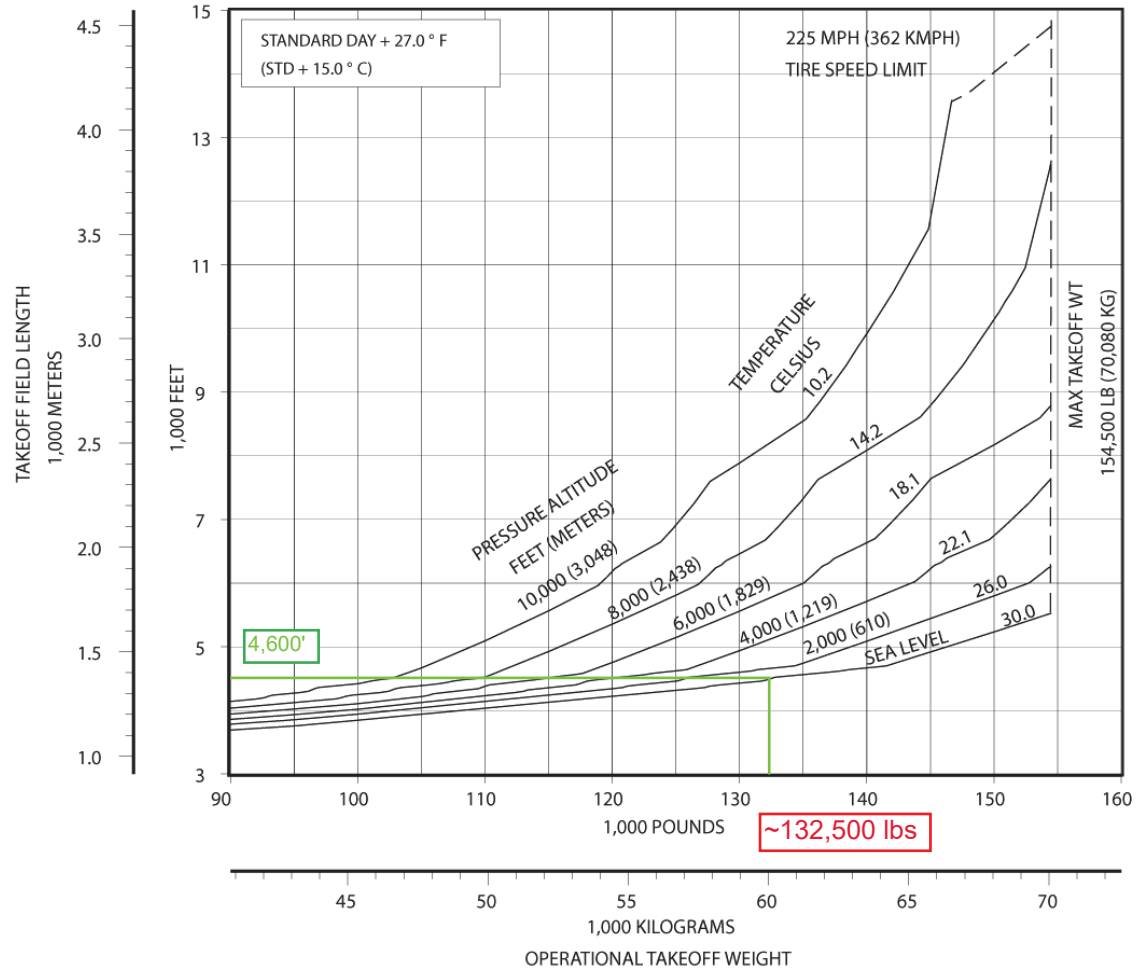

### 3.4 F.A.R. AND J.A.R. LANDING RUNWAY LENGTH REQUIREMENTS

#### 3.4.1 F.A.R. Landing Runway Length Requirements - Flaps 40: Model 737-100

NOTES:

- \*  $V_{APP} = 1.3V_s$
- \* ZERO WIND
- \* FLAP POSITION 40
- \* AUTOMATIC SPEED BRAKES
- \* CONSULT WITH USING AIRLINE FOR SPECIFIC PROCEDURE PRIOR TO FACILITY DESIGN

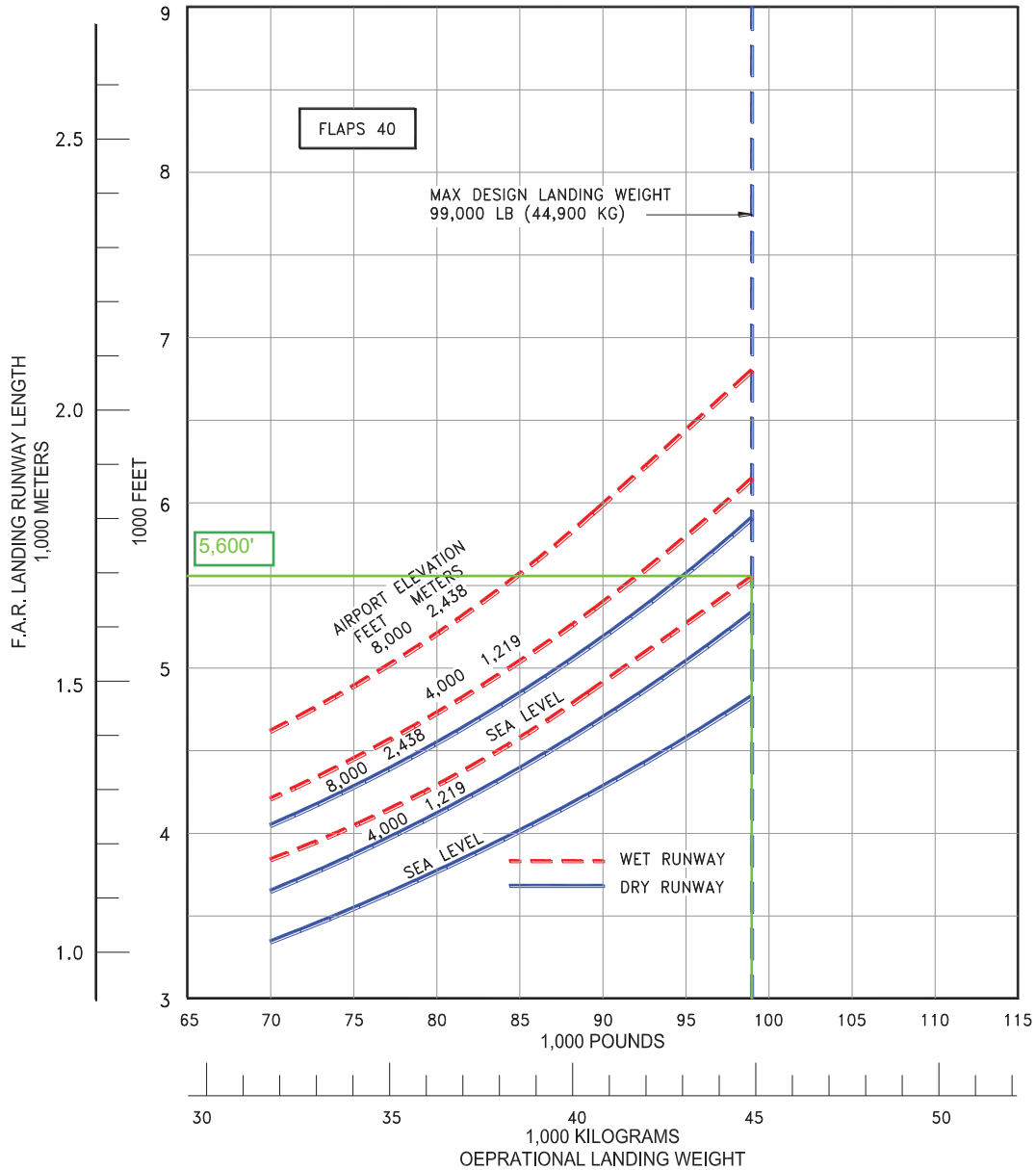

### 3.4.4 F.A.R. Landing Runway Length Requirements - Flaps 40: Model 737-200, -200C

NOTES:

- \*  $V_{APP} = 1.3V_S$
- \* ZERO WIND
- \* FLAP POSITION 40
- \* AUTOMATIC SPEED BRAKES
- \* CONSULT WITH USING AIRLINE FOR SPECIFIC PROCEDURE PRIOR TO FACILITY DESIGN

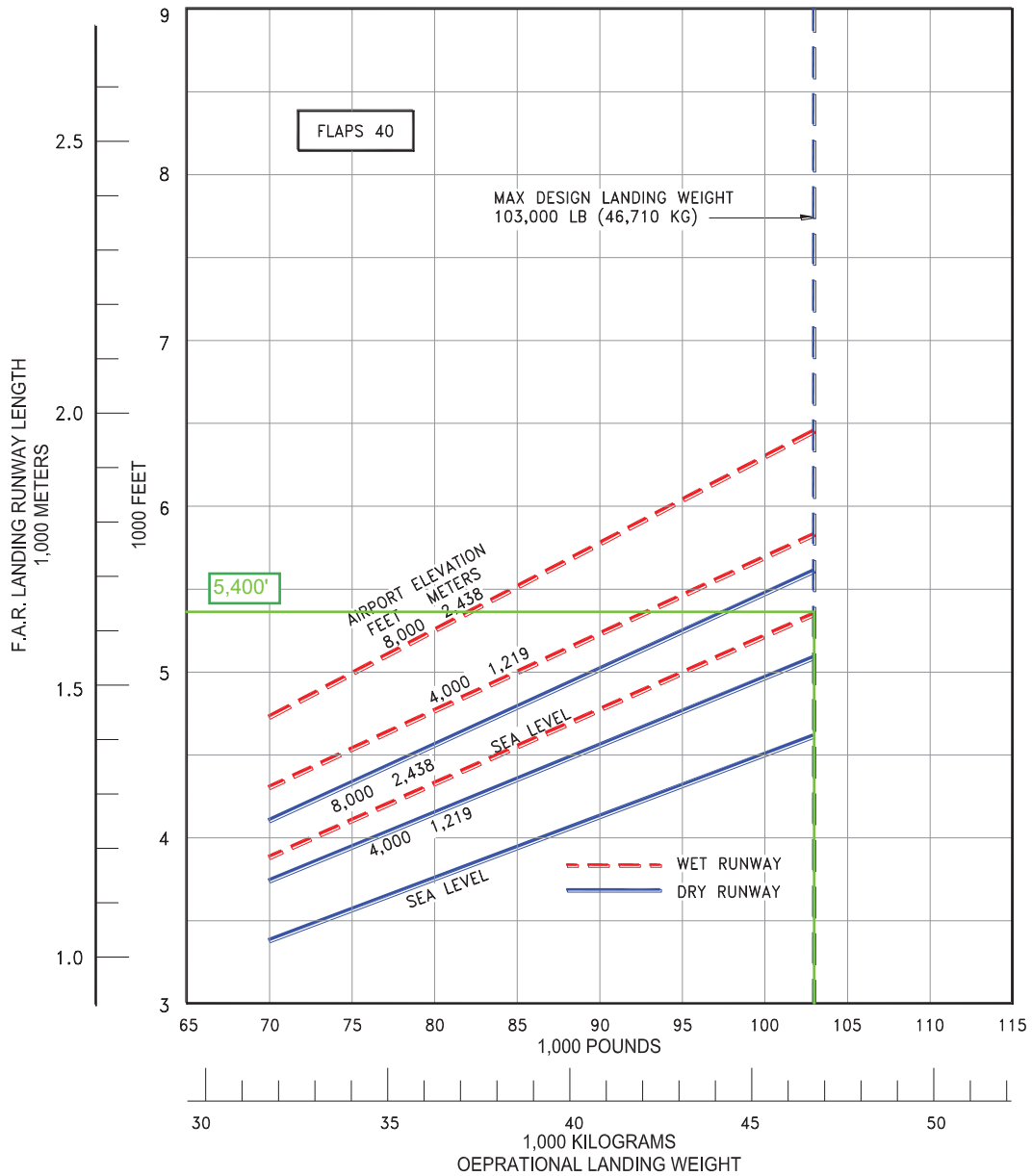

### 3.4.10 F.A.R. Landing Runway Length Requirements - Flaps 40: Model 737-300

NOTES:

- \*  $V_{APP} = 1.3V_S$
- \* ZERO WIND, ZERO RUNWAY GRADIENT
- \* FLAP POSITION 40
- \* AUTOMATIC SPEED BRAKES
- \* CONSULT WITH USING AIRLINE FOR SPECIFIC PROCEDURE PRIOR TO FACILITY DESIGN

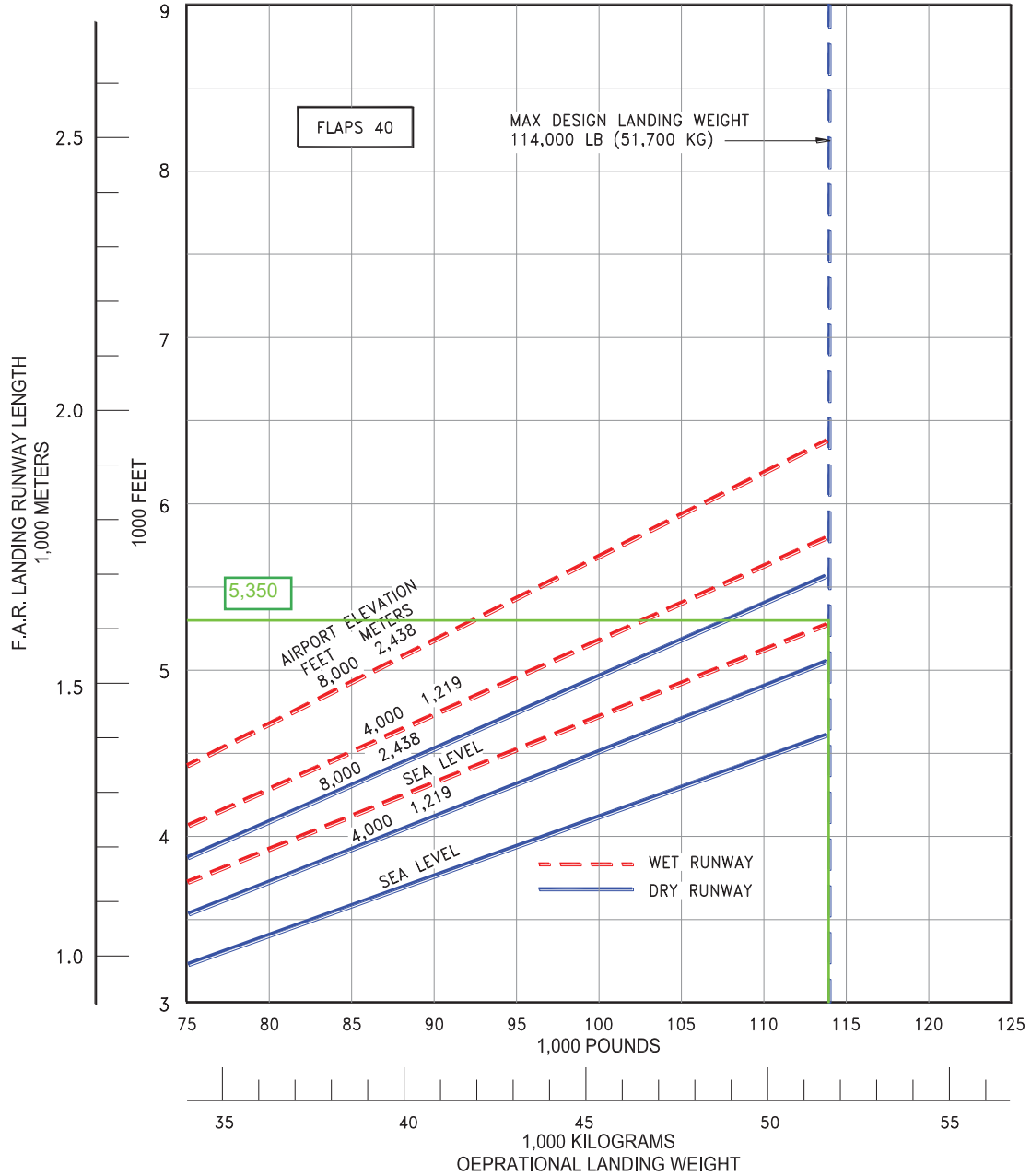

### 3.4.13 F.A.R. Landing Runway Length Requirements - Flaps 40: Model 737-400

NOTES:

- \*  $V_{APP} = 1.3V_S$
- \* ZERO WIND, ZERO RUNWAY GRADIENT
- \* FLAP POSITION 40
- \* AUTOMATIC SPEED BRAKES
- \* CONSULT WITH USING AIRLINE FOR SPECIFIC PROCEDURE PRIOR TO FACILITY DESIGN

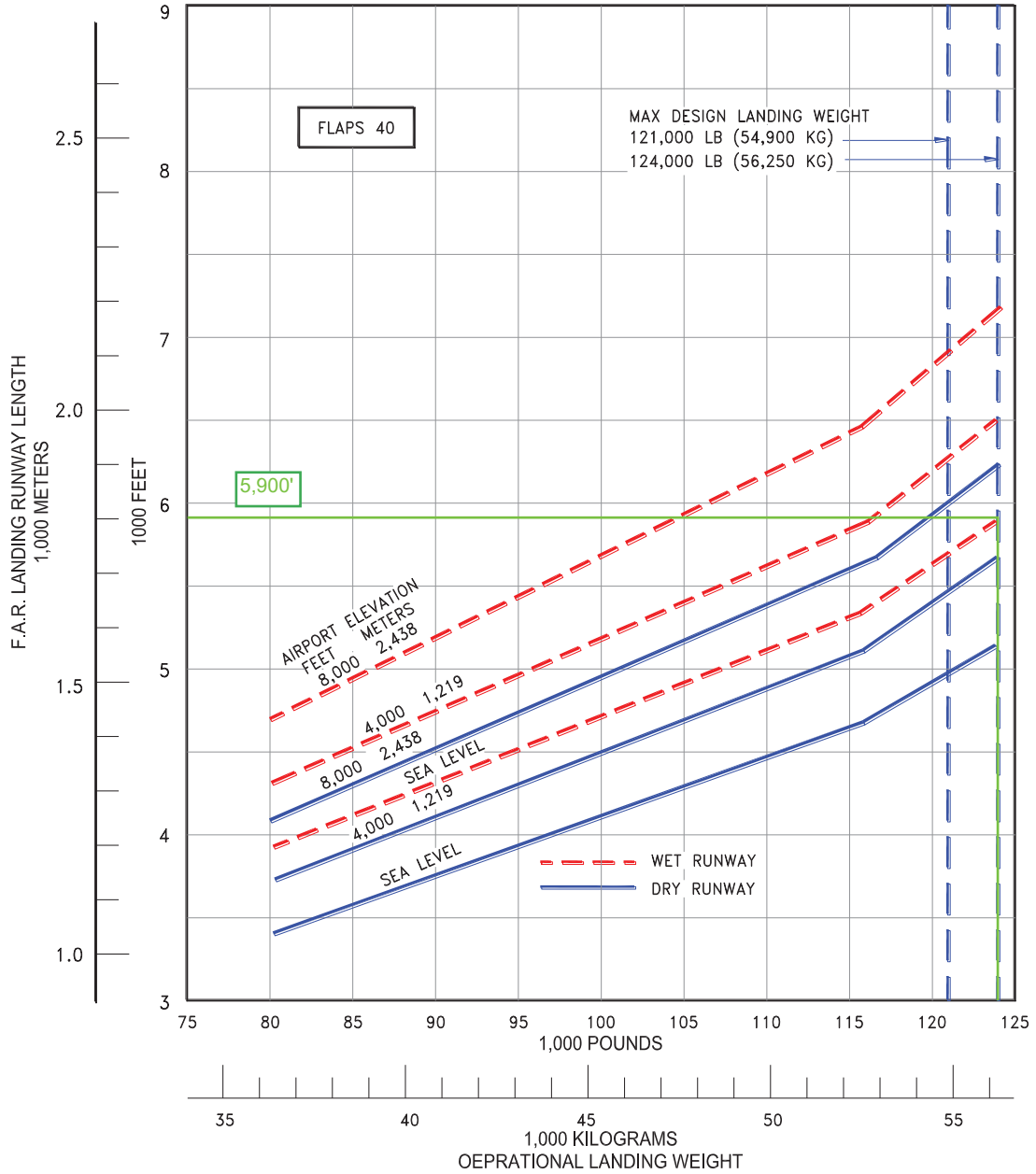

### 3.4.20 F.A.R. Landing Runway Length Requirements - Flaps 30: Model 737-700ER

DO NOT USE FOR DISPATCH

Landing Field Length  
737-700/-700W/-700ER/-700ERW/-700C/-700CW/BBJ1 (CFM56-7B Series)

- STANDARD DAY, ZERO WIND
- AUTO SPOILERS OPERATIVE
- ANTI-SKID OPERATIVE
- ZERO RUNWAY GRADIENT
- CONSULT USING AIRLINE FOR SPECIFIC OPERATING PROCEDURE PRIOR TO FACILITY DESIGN

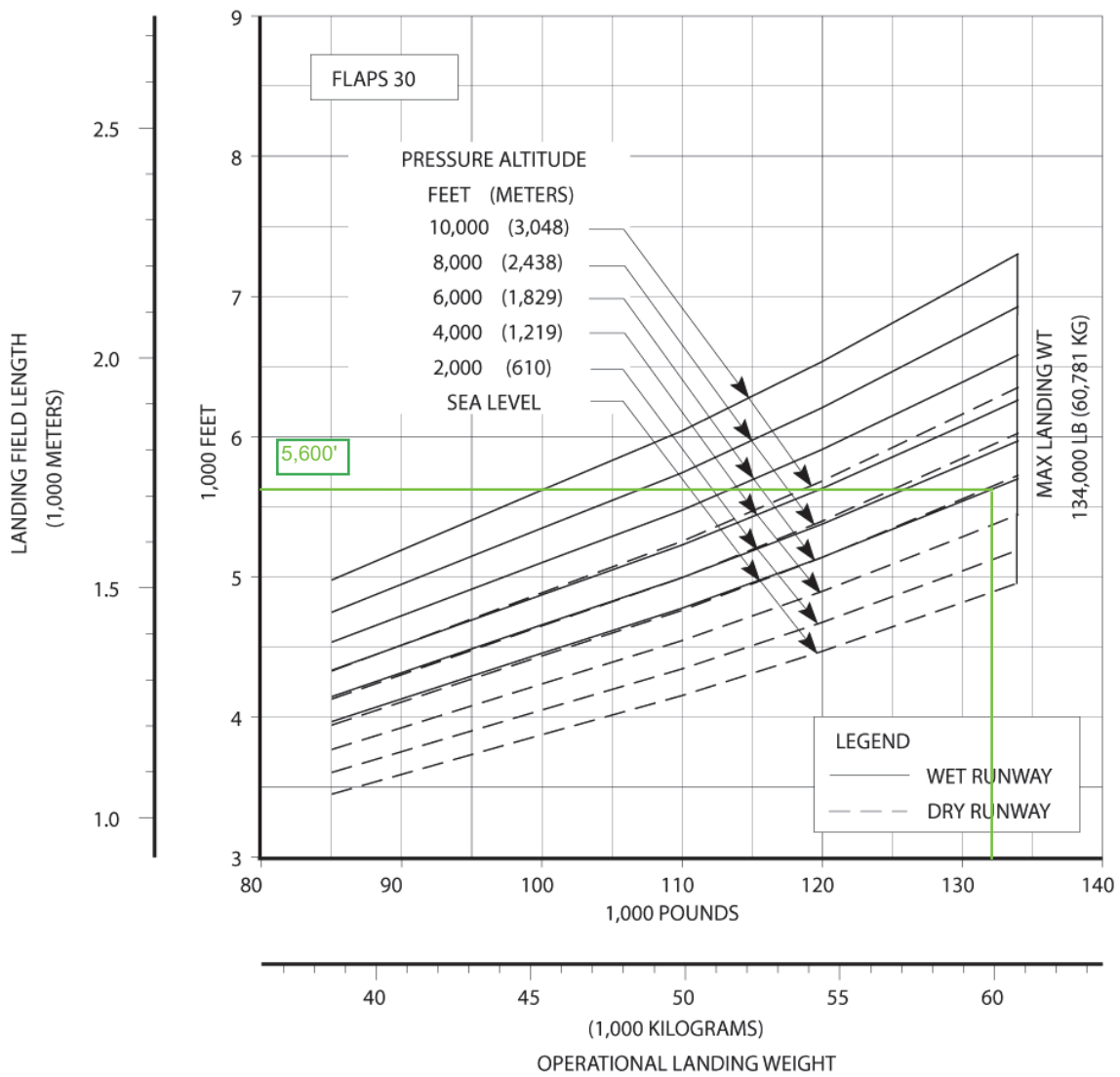

NOTE: DOMESTIC RESERVES AT  
200 NAUTICAL MILES ALTERNATE  
PLUS 45 MINUTES AT LRC

- STANDARD DAY
- NO WIND
- OEW = 61,335 POUNDS
- JT8D - 15 ENGINES

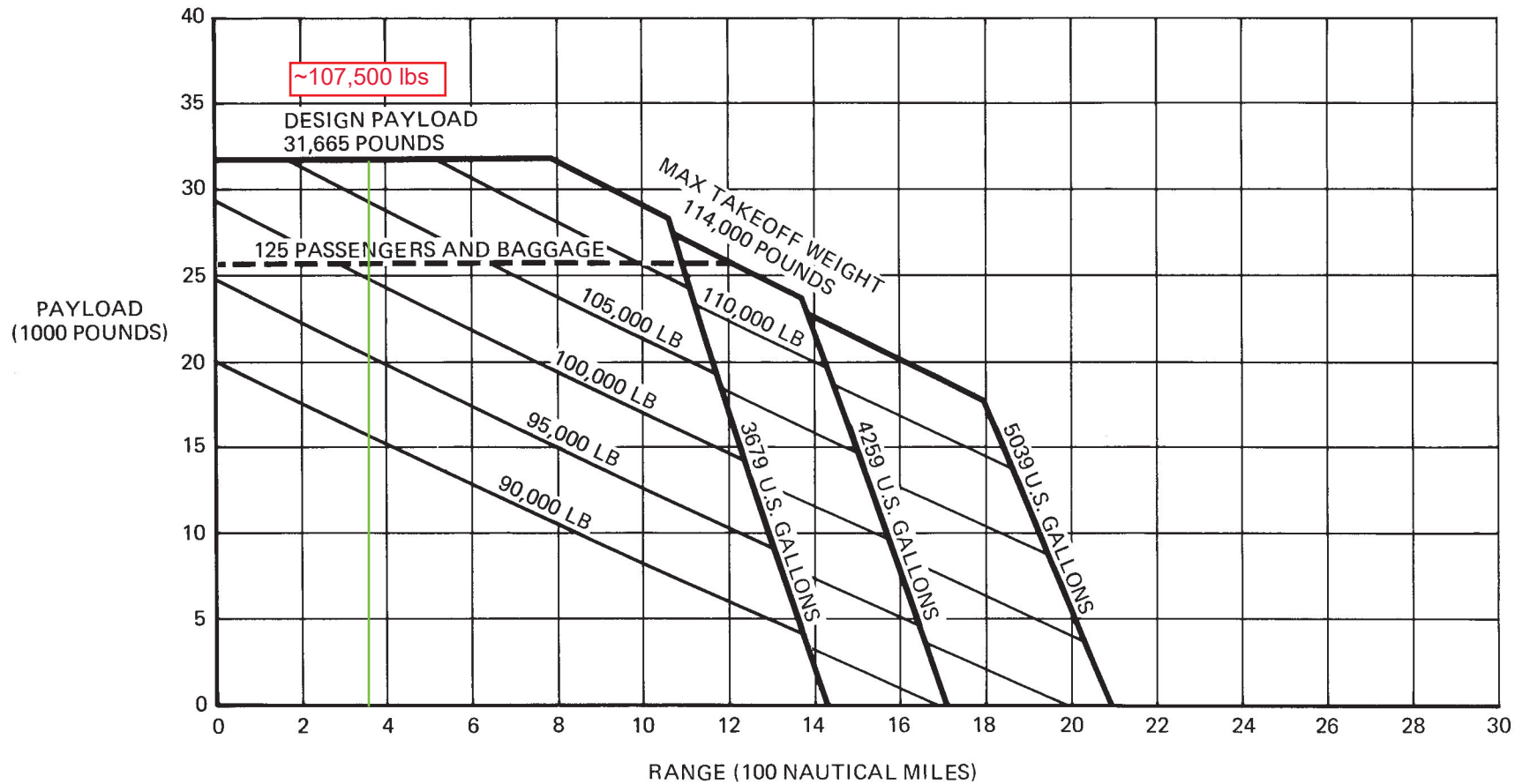

Assumes range at 350 miles for ANC - DLG

### 3.2 PAYLOAD-RANGE PAYLOAD-RANGE FOR TYPICAL LONG-RANGE CRUISE AT 30,000 FT MODEL DC-9-41

NOTES:

- JT8D-15 ENGINES
- MAX TAKEOFF POWER
- ZERO RUNWAY GRADIENT
- ZERO WIND
- COORDINATE WITH USING AIRLINE FOR SPECIFIC REQUIREMENTS PRIOR TO FACILITY DESIGN

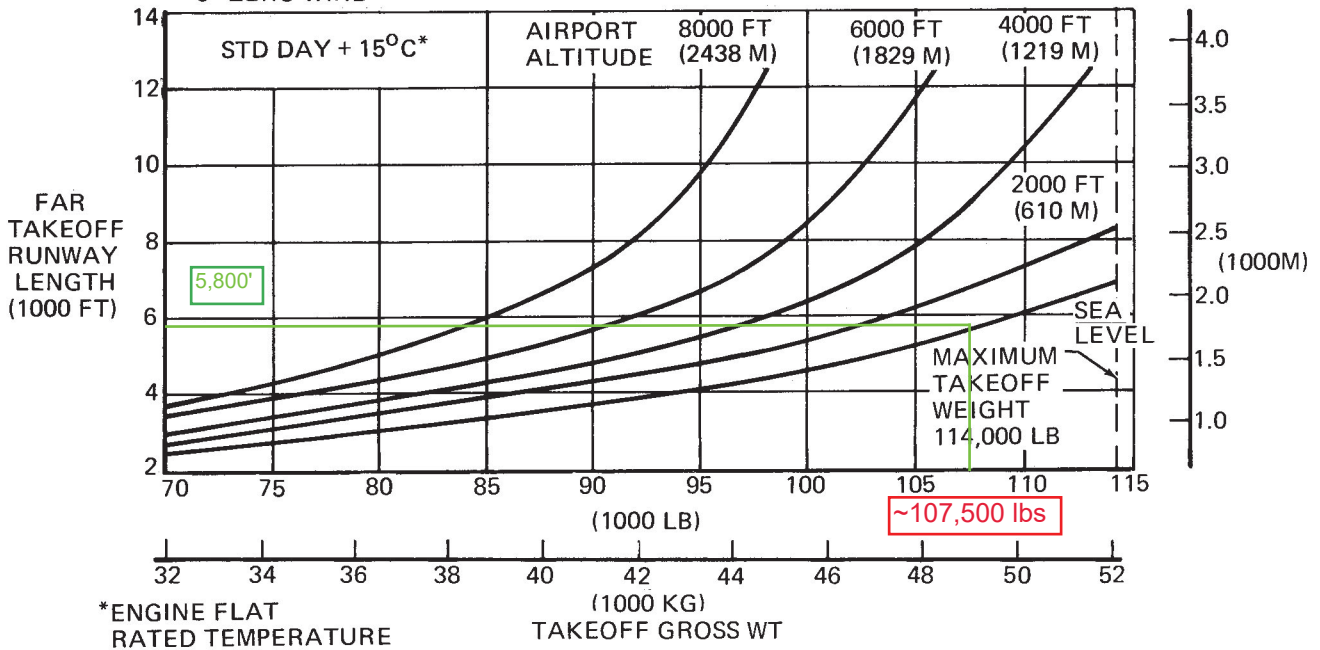

NOTES:

- JT8D-15 ENGINES
- MAX TAKEOFF POWER
- ZERO RUNWAY GRADIENT
- ZERO WIND
- COORDINATE WITH USING AIRLINE FOR SPECIFIC REQUIREMENTS PRIOR TO FACILITY DESIGN

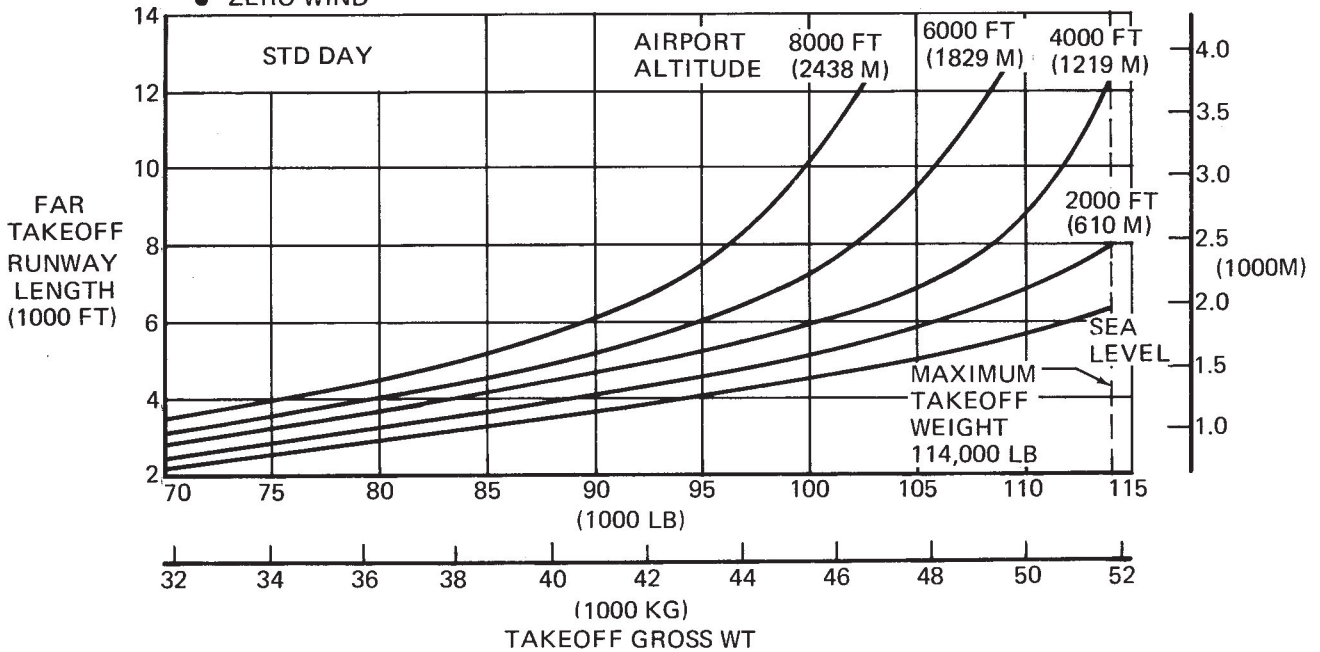

### 3.3 FAR TAKEOFF RUNWAY LENGTH REQUIREMENTS MODEL DC-9-41



NOTES:

- STANDARD DAY
  - 3-DEG GLIDESLOPE
  - ZERO WIND AT 50-FOOT HEIGHT
  - ZERO RUNWAY GRADIENT
  - COORDINATE WITH USING AIRLINES FOR SPECIFIC REQUIREMENTS PRIOR TO FACILITY DESIGN
  - $V_{APP} = 1.3 V_S$  FAR (DRY AND WET RUNWAY)
- $V_{APP}$  IS APPROACH VELOCITY  
 $V_S$  IS STALL VELOCITY

LEGEND  
 ——— WET RUNWAY  
 - - - DRY RUNWAY

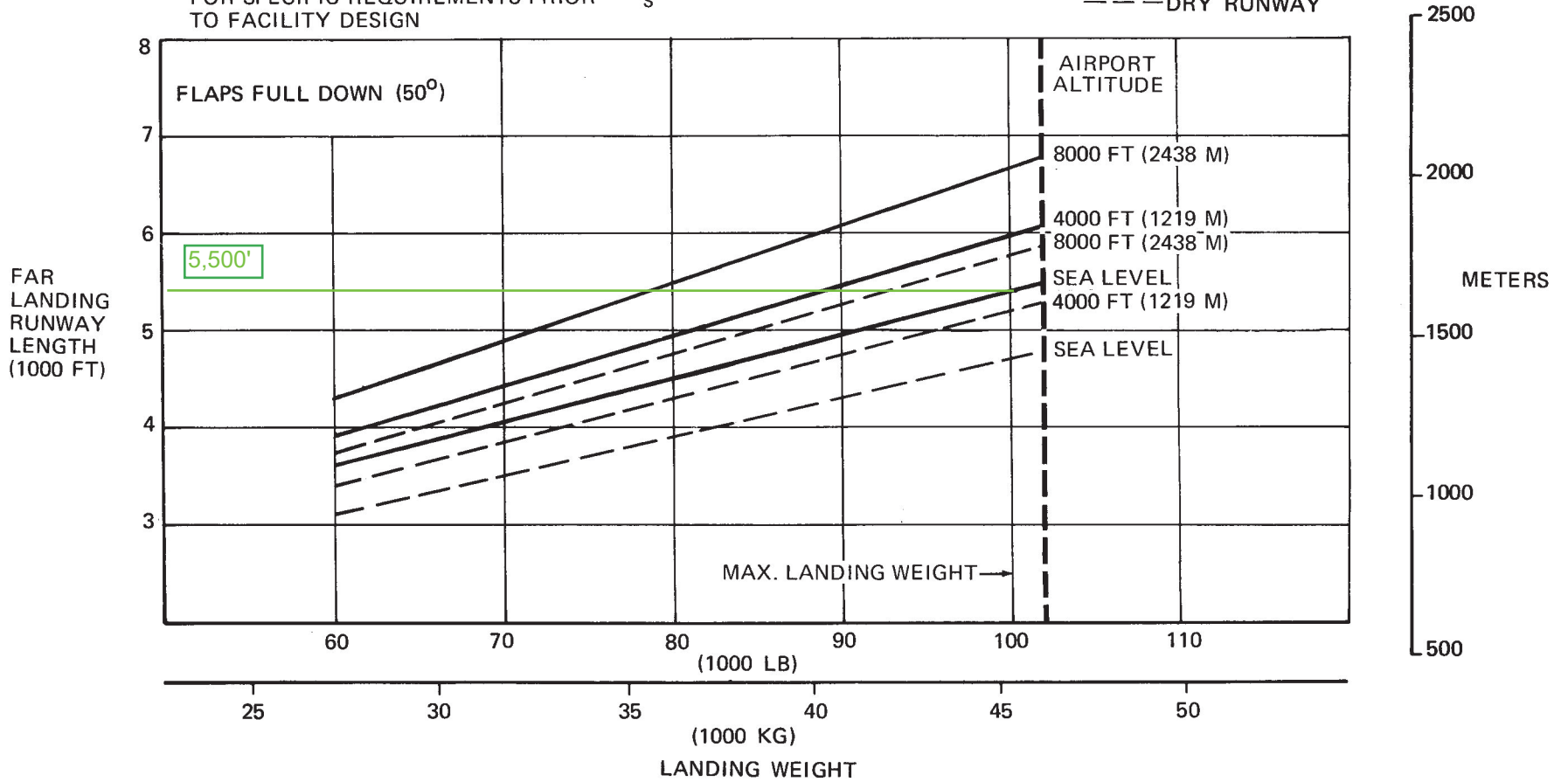

### 3.4 FAR LANDING RUNWAY LENGTH REQUIREMENTS MODEL DC-9-41

NOTE: RESERVES BASED ON  
 FAR 121.639  
 200 N MI DISTANCE  
 TO ALTERNATE

- STANDARD DAY
- NO WIND
- OEW = 78,549 LB
- JT8D-217/217A ENGINES

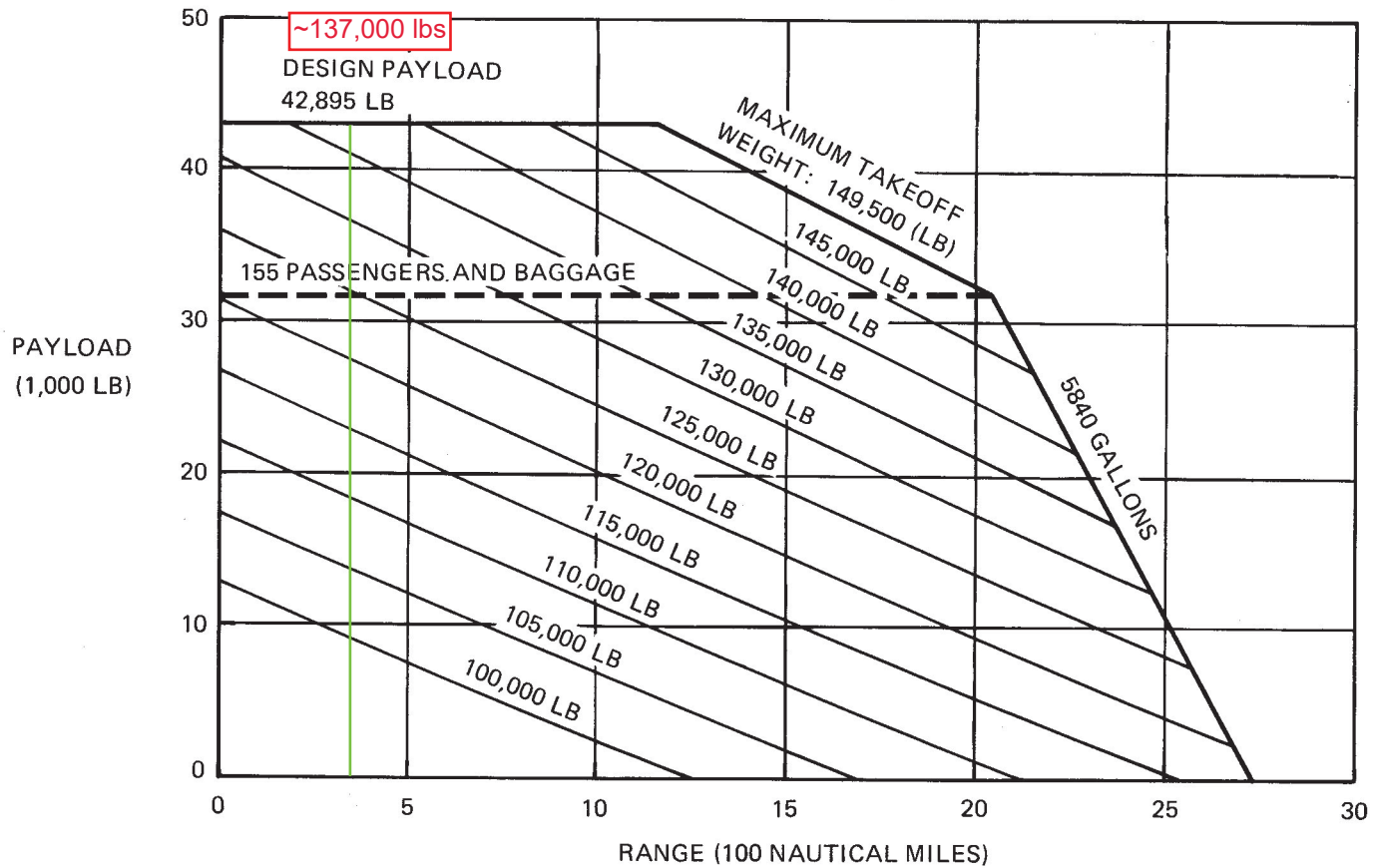

Assumes range at 350 miles for ANC - DLG

**3.2 PAYLOAD-RANGE**  
**PAYLOAD-RANGE FOR TYPICAL LONG-RANGE CRUISE AT 31,000 FT/35,000 FT STEP**  
**MODEL MD-82 AND -88**

NOTES:

- JT8D-217 ENGINES
- NORMAL TAKEOFF THRUST AND ART
- ZERO RUNWAY GRADIENT
- ZERO WIND
- COORDINATE WITH USING AIRLINE FOR SPECIFIC REQUIREMENTS PRIOR TO FACILITY DESIGN

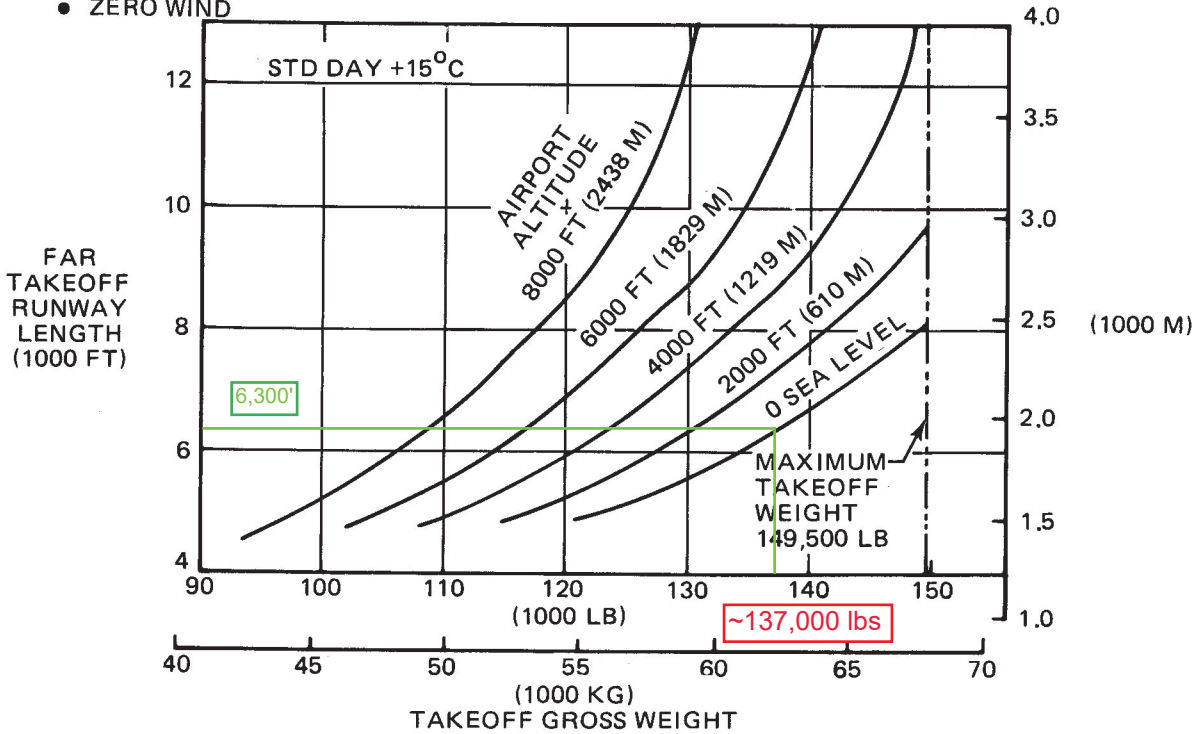

NOTES:

- JT8D-217 ENGINES
- NORMAL TAKEOFF THRUST AND ART
- ZERO RUNWAY GRADIENT
- ZERO WIND
- COORDINATE WITH USING AIRLINE FOR SPECIFIC REQUIREMENTS PRIOR TO FACILITY DESIGN

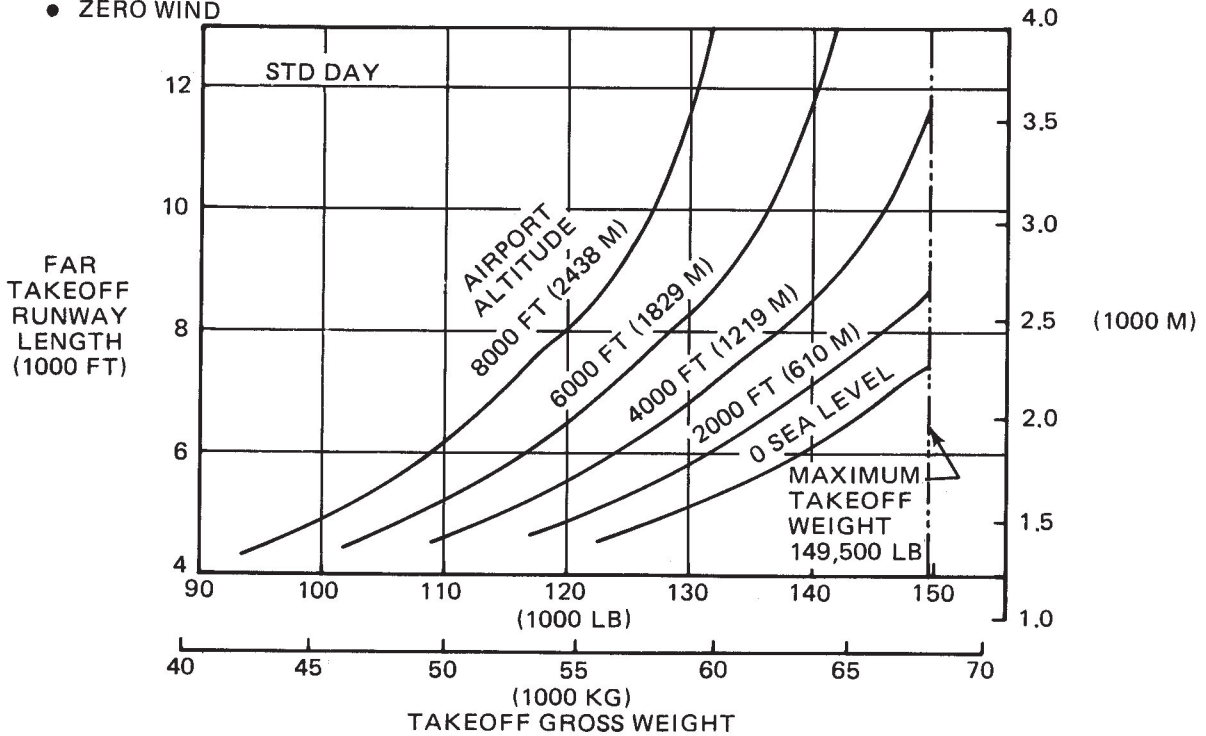

### 3.3 FAR TAKEOFF RUNWAY LENGTH REQUIREMENTS MODEL MD-82

NOTES:

- JT8D-217A ENGINES
- NORMAL TAKEOFF THRUST AND ART
- ZERO RUNWAY GRADIENT
- ZERO WIND
- COORDINATE WITH USING AIRLINE FOR SPECIFIC REQUIREMENTS PRIOR TO FACILITY DESIGN

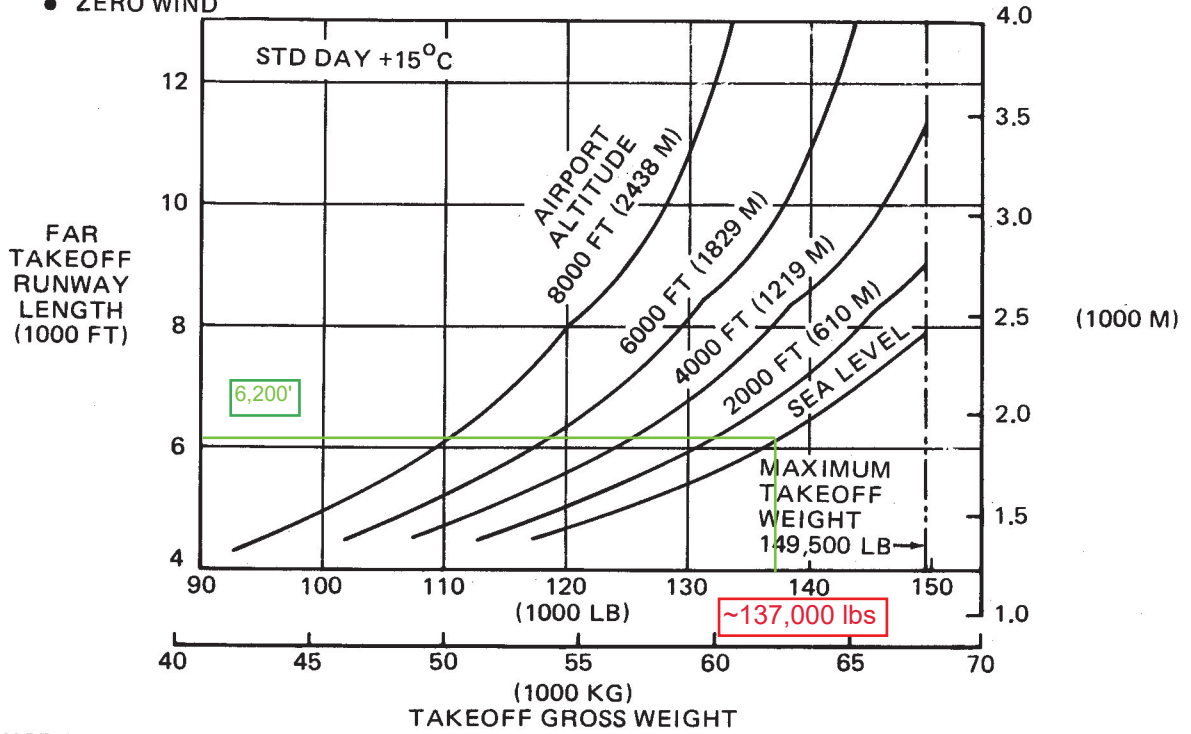

NOTES:

- JT8D-217A ENGINES
- NORMAL TAKEOFF THRUST AND ART
- ZERO RUNWAY GRADIENT
- ZERO WIND
- COORDINATE WITH USING AIRLINE FOR SPECIFIC REQUIREMENTS PRIOR TO FACILITY DESIGN

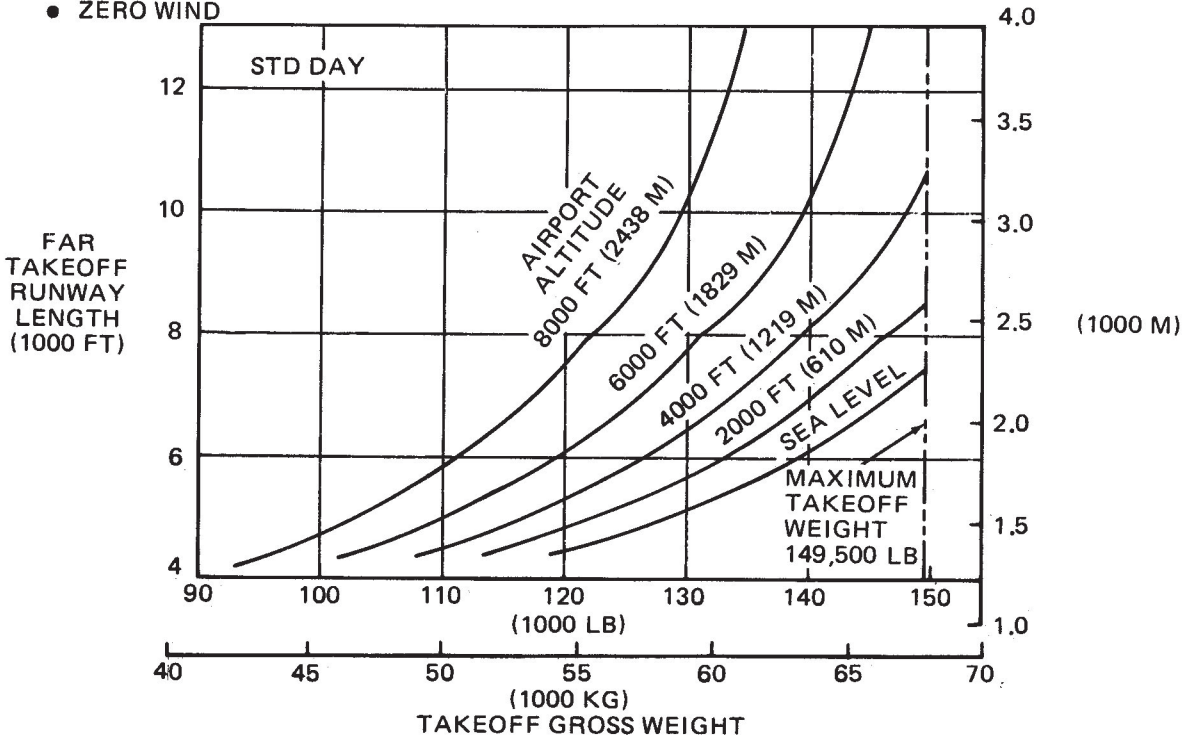

### 3.3 FAR TAKEOFF RUNWAY LENGTH REQUIREMENTS MODEL MD-82 AND -88

NOTES:

- JT8D-219 ENGINES
- NORMAL TAKEOFF THRUST AND ART
- ZERO RUNWAY GRADIENT
- ZERO WIND
- COORDINATE WITH USING AIRLINE FOR SPECIFIC REQUIREMENTS PRIOR TO FACILITY DESIGN

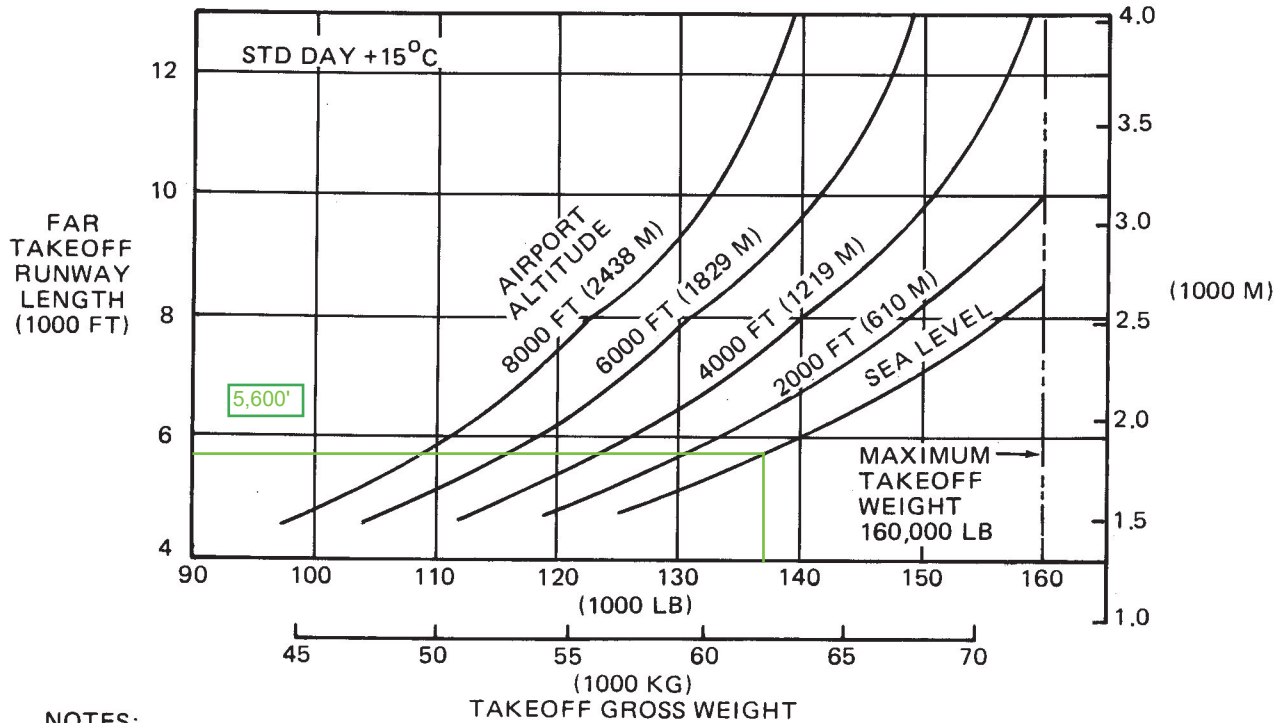

NOTES:

- JT8D-219 ENGINES
- NORMAL TAKEOFF THRUST AND ART
- ZERO RUNWAY GRADIENT
- ZERO WIND
- COORDINATE WITH USING AIRLINE FOR SPECIFIC REQUIREMENTS PRIOR TO FACILITY DESIGN

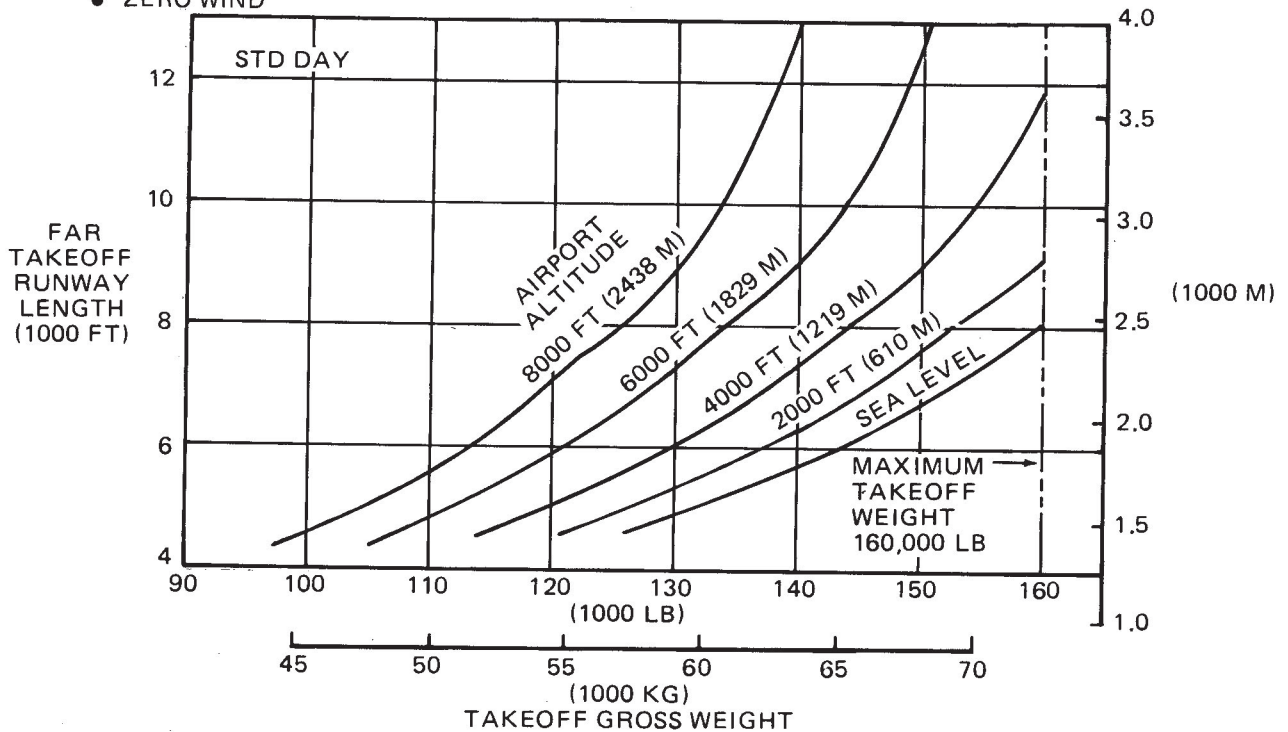

### 3.3 FAR TAKEOFF RUNWAY LENGTH REQUIREMENTS MODEL MD-83

NOTES:

- STANDARD DAY
- 3-DEG GLIDESLOPE
- SLATS EXTENDED
- ZERO WIND AT 50-FOOT HEIGHT
- ZERO RUNWAY GRADIENT
- COORDINATE WITH USING AIRLINES FOR SPECIFIC REQUIREMENTS PRIOR TO FACILITY DESIGN

- $V_{APP} = 1.3 V_S$  FAR
- = (DRY AND WET RUNWAY)
- $V_{APP}$  IS APPROACH VELOCITY
- $V_S$  IS STALL VELOCITY

LEGEND

- WET RUNWAY
- - - DRY RUNWAY

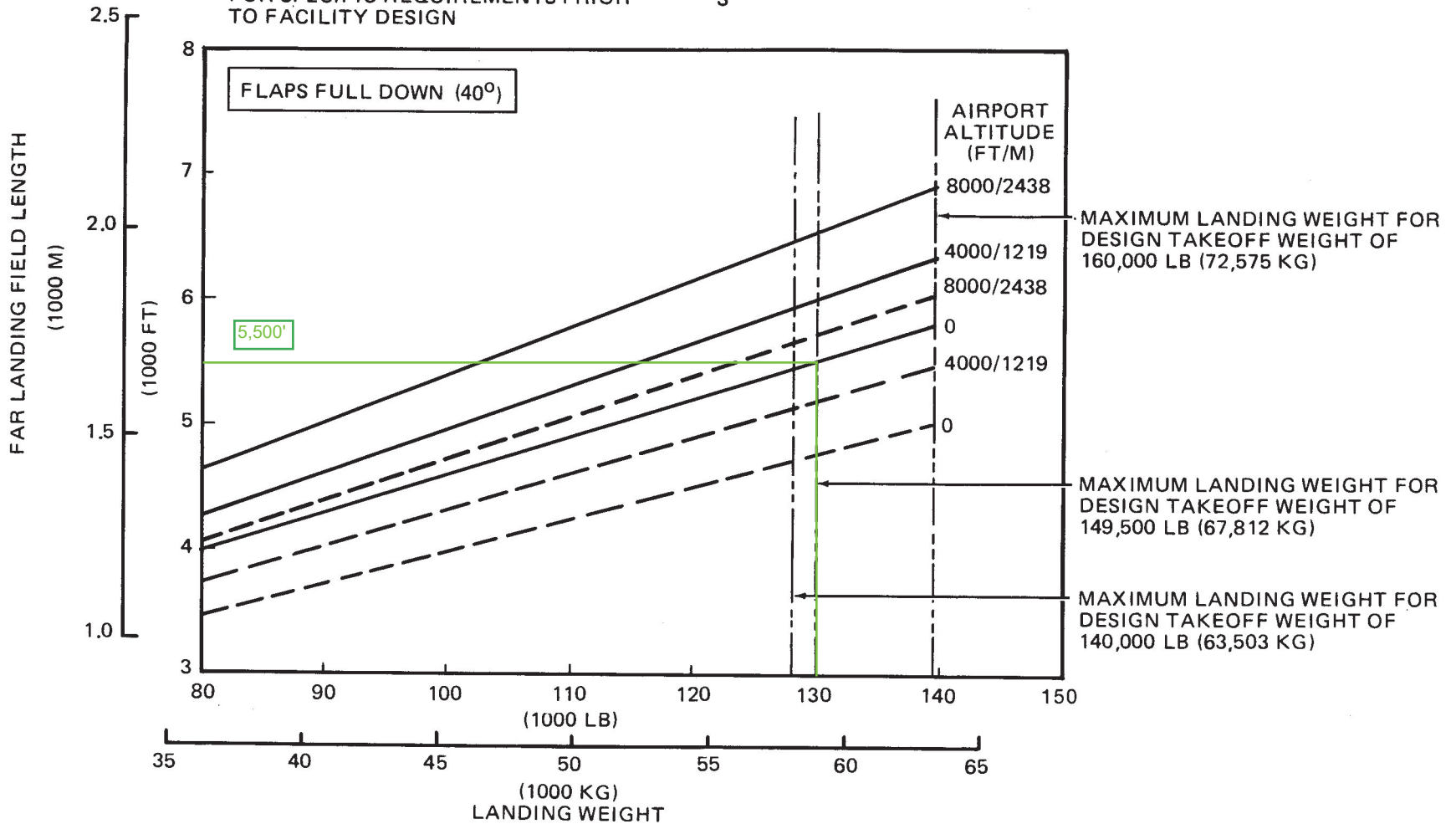

**3.4 FAR LANDING RUNWAY LENGTH REQUIREMENTS  
MODEL MD-81, -82, -83, AND -88**

### 3.2.12 Payload/Range for Long Range Cruise: Model 737-800

DO NOT USE FOR DISPATCH

Payload/Range  
737-800/800W/BBJ2 (CFM56-7B Series)

- STANDARD DAY, ZERO WIND
- CRUISE MACH = LRC
- NORMAL POWER EXTRACTION AND AIR CONDITIONING BLEEDS
- TYPICAL MISSION RULES
- NON-WINGLET PERFORMANCE SHOWN. WINGLET AIRCRAFT WILL HAVE SLIGHTLY GREATER RANGE.
- CONSULT USING AIRLINE FOR SPECIFIC OPERATING PROCEDURE AND OEW PRIOR TO FACILITY DESIGN.

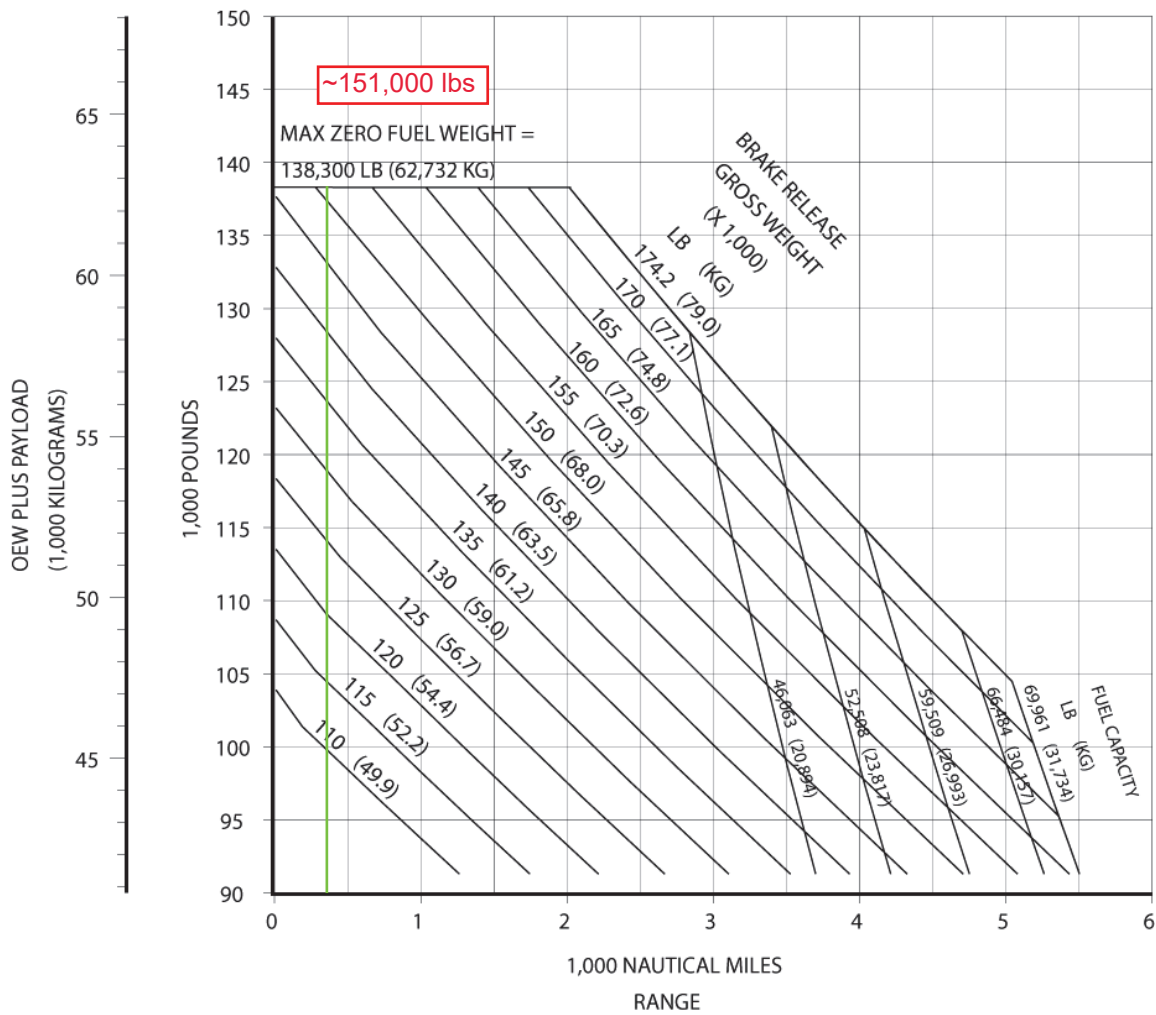

Assume range at 350 miles for ANC - DLG

### 3.2.13 Payload/Range for Long Range Cruise: Model 737-900

DO NOT USE FOR DISPATCH

Payload/Range  
737-900/-900W (CFM56-7B Series)

- STANDARD DAY, ZERO WIND
- CRUISE MACH = LRC
- NORMAL POWER EXTRACTION AND AIR CONDITIONING BLEEDS
- TYPICAL MISSION RULES
- NON-WINGLET PERFORMANCE SHOWN. WINGLET AIRCRAFT WILL HAVE SLIGHTLY GREATER RANGE.
- CONSULT USING AIRLINE FOR SPECIFIC OPERATING PROCEDURE AND OEW PRIOR TO FACILITY DESIGN.

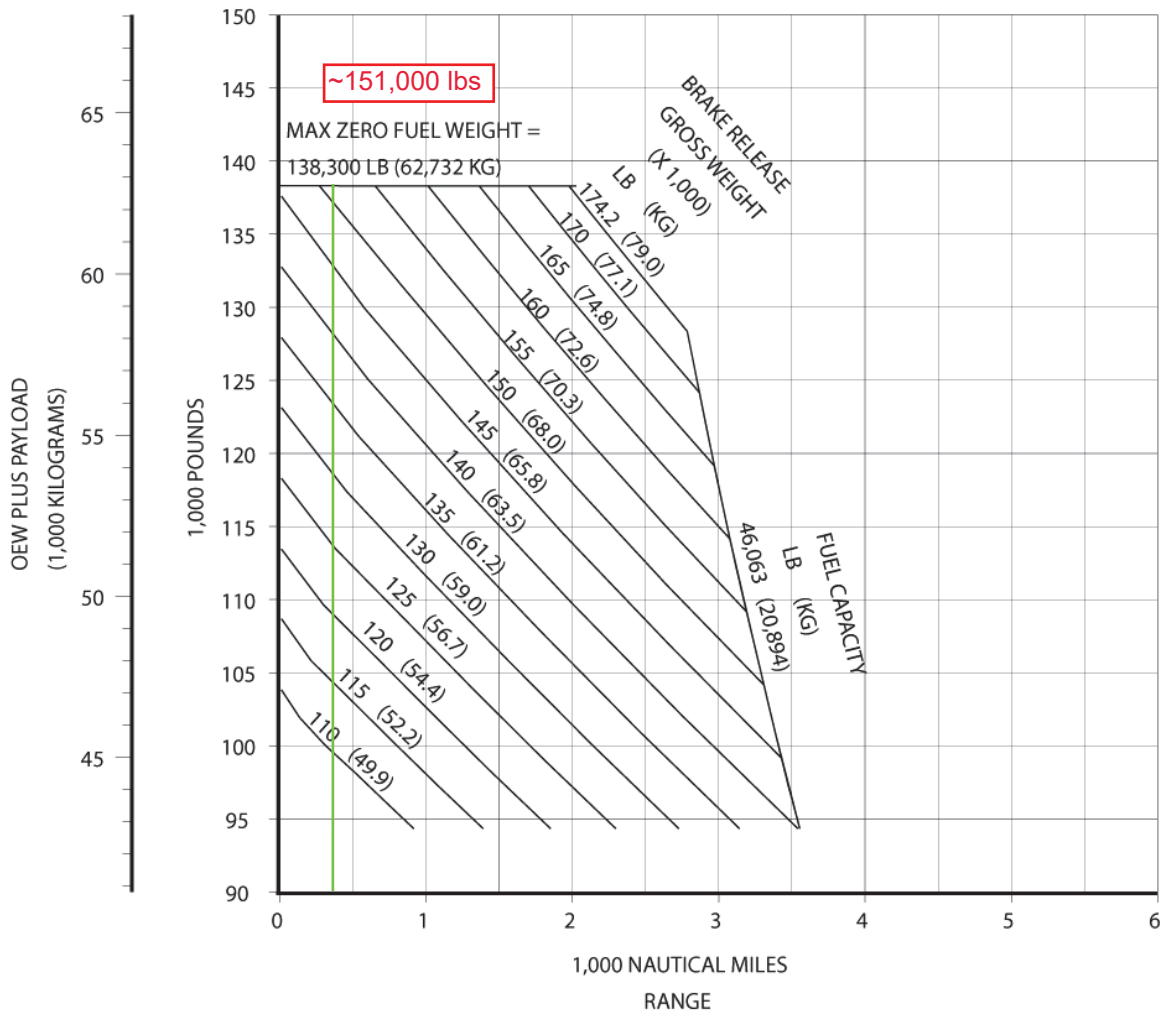



### 3.2.14 Payload/Range for Long Range Cruise: Model 737-900ER

DO NOT USE FOR DISPATCH

Payload/Range  
737-900ER/900ERW/BBJ3 (CFM56-7B Series)

- STANDARD DAY, ZERO WIND
- CRUISE MACH = LRC
- NORMAL POWER EXTRACTION AND AIR CONDITIONING BLEEDS
- TYPICAL MISSION RULES
- NON-WINGLET PERFORMANCE SHOWN. WINGLET AIRCRAFT WILL HAVE SLIGHTLY GREATER RANGE.
- CONSULT USING AIRLINE FOR SPECIFIC OPERATING PROCEDURE AND OEW PRIOR TO FACILITY DESIGN.

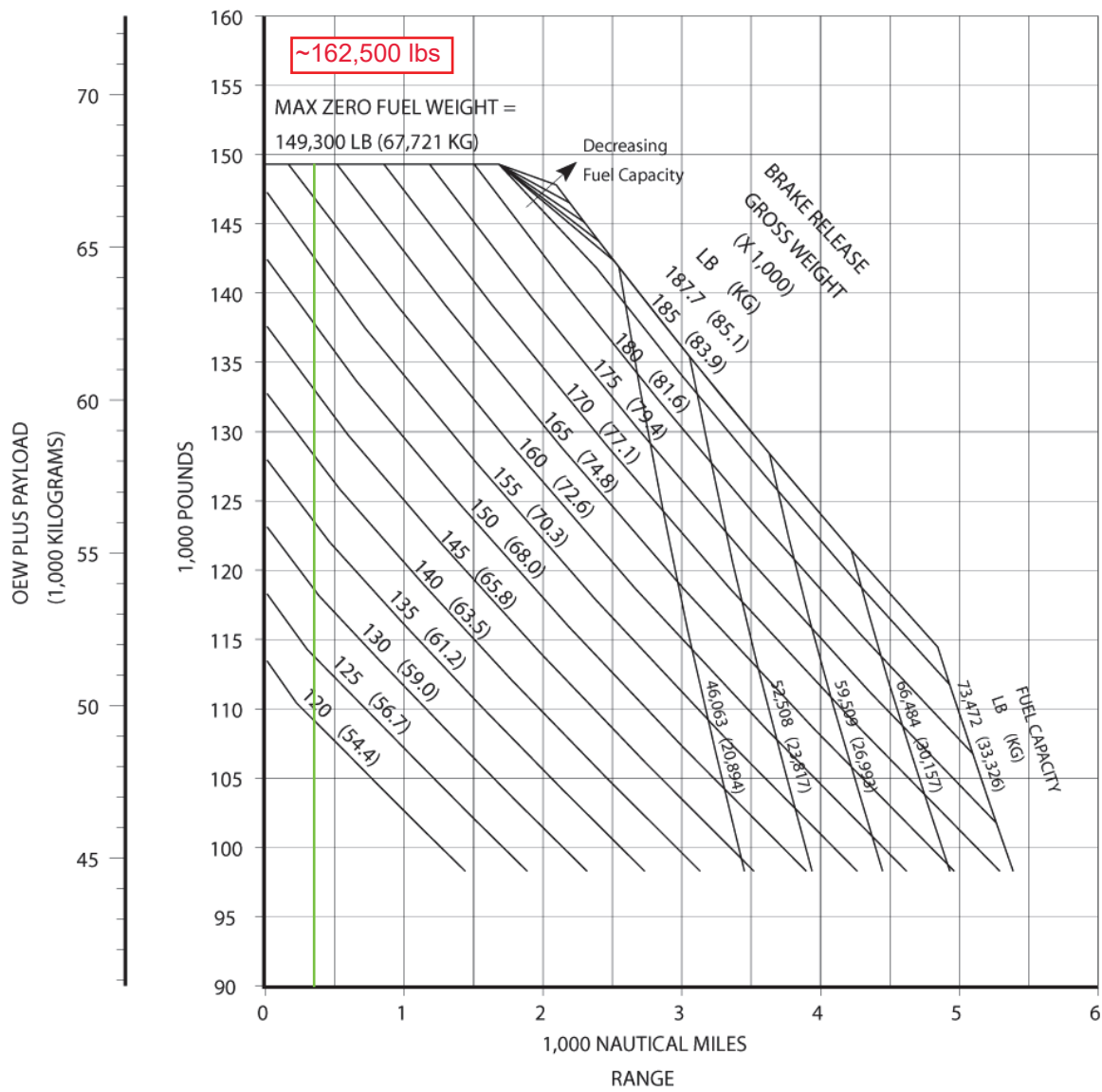

**3.3.48 F.A.R. Takeoff Runway Length Requirements - Standard Day + 27°F (STD + 15°C), Dry Runway: Model 737-800/-800W/BBJ2 (CFM56-7B27-B1 Engine at 26,000 LB SLST)**

DO NOT USE FOR DISPATCH

**Takeoff Runway Length Requirements  
737-800/-800W/BBJ2 (CFM56-7B27-B1)**

DRY RUNWAY / ZERO WIND  
ZERO RUNWAY GRADIENT  
AIR CONDITIONING OFF  
OPTIMUM FLAP SETTING

- WINGLET, SHORT FIELD PACKAGE, AND CARBON BRAKES PERFORMANCE SHOWN.
- NON-WINGLET AND NON SHORT FIELD PACKAGE AIRCRAFT WILL HAVE SLIGHTLY WORSE PERFORMANCE.
- CONSULT USING AIRLINE FOR SPECIFIC OPERATING PROCEDURE PRIOR TO FACILITY DESIGN.

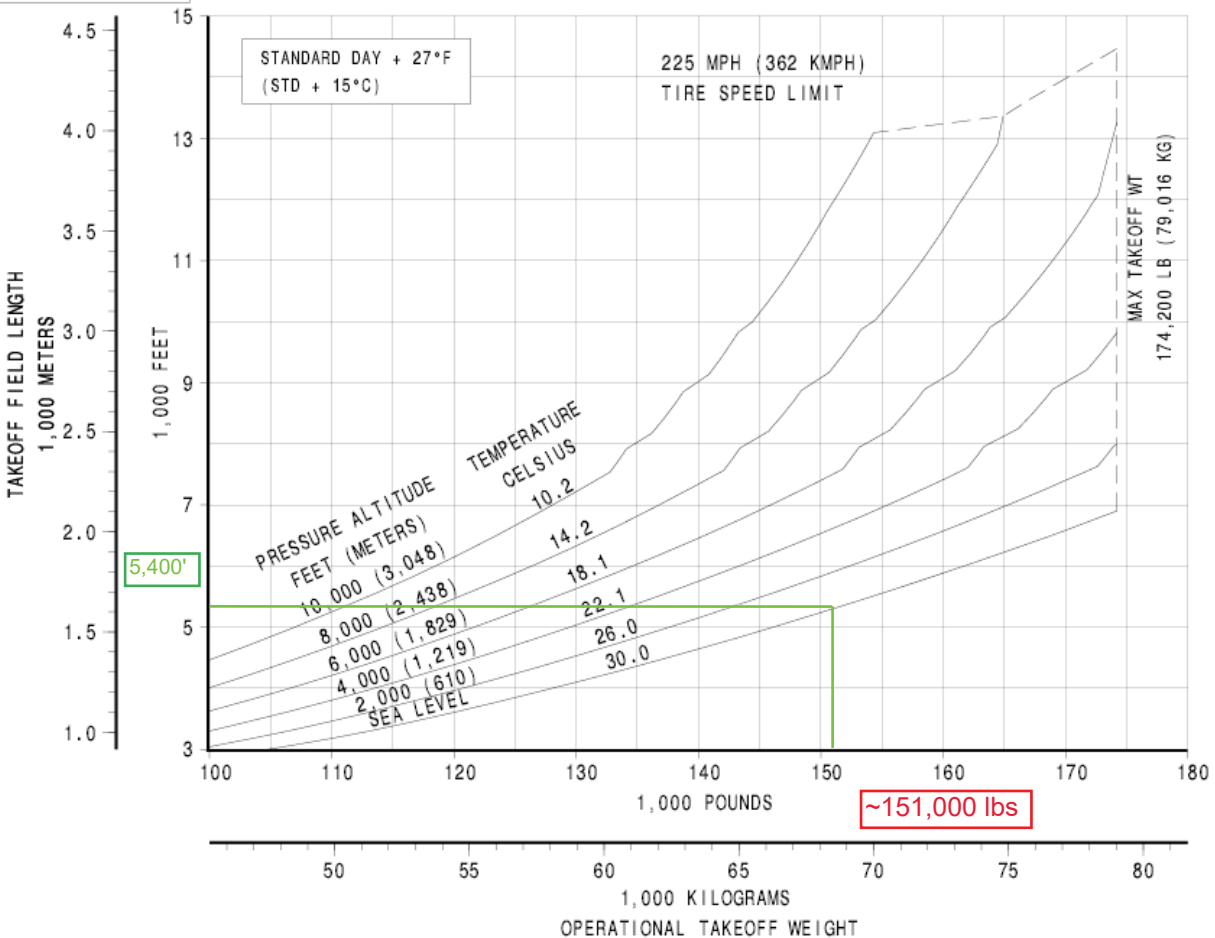

**3.3.52 F.A.R. Takeoff Runway Length Requirements - Standard Day + 27°F (STD + 15°C), Dry Runway: Model 737-800 / -800W / BBJ2 (CFM56-7B24/-7B26/-7B27 Engines at 26,000 LB SLST)**

**DO NOT USE FOR DISPATCH**

**Takeoff Runway Length Requirements**

**737-800/-800W/BBJ2 (CFM56-7B24/-7B26/-7B27)**

- NON-WINGLET PERFORMANCE SHOWN. WINGLET AIRCRAFT WILL HAVE SLIGHTLY IMPROVED PERFORMANCE.
- CONSULT USING AIRLINE FOR SPECIFIC OPERATING PROCEDURE PRIOR TO FACILITY DESIGN.

DRY RUNWAY  
ZERO WIND  
ZERO RUNWAY GRADIENT  
AIR CONDITIONING OFF  
OPTIMUM FLAP SETTING

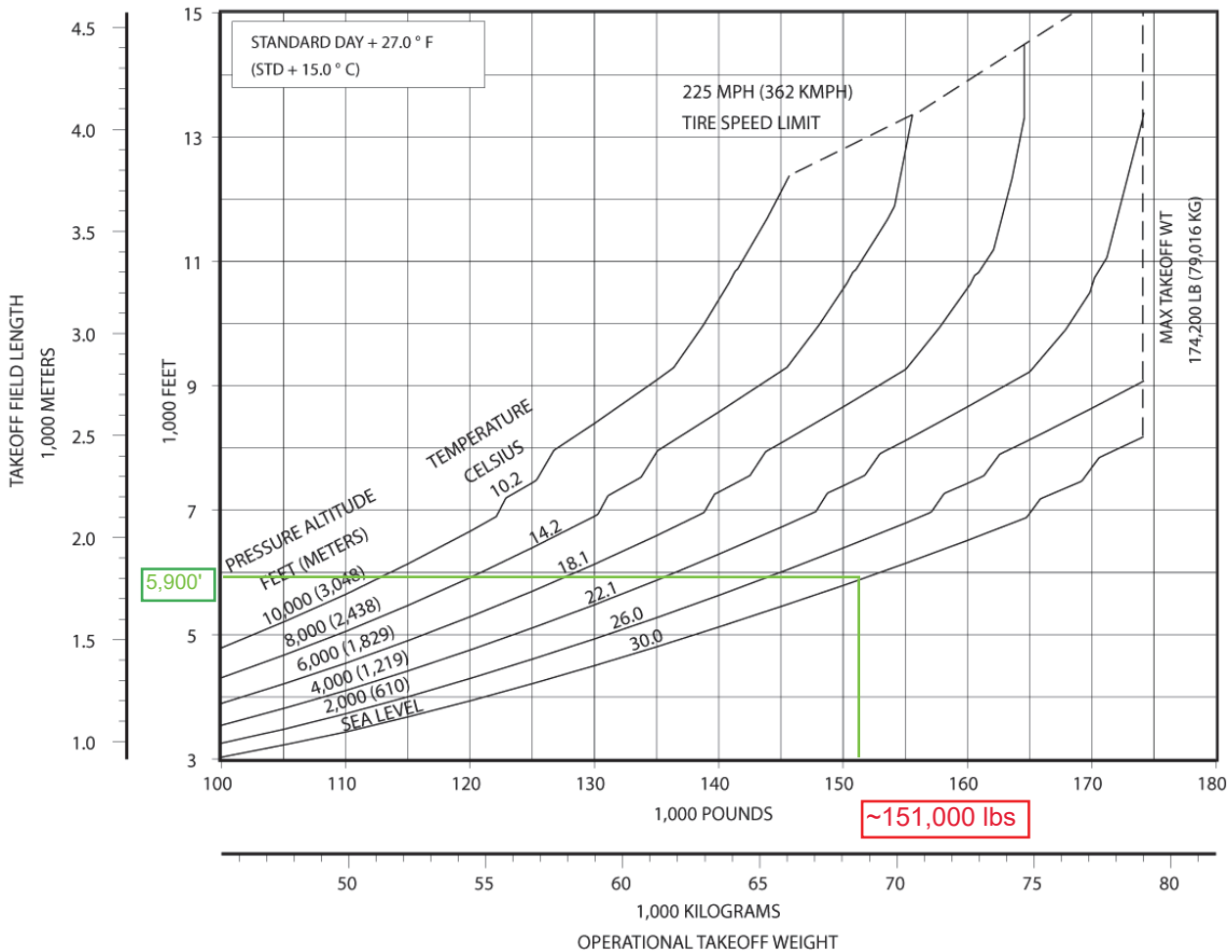

**3.3.56 F.A.R. Takeoff Runway Length Requirements - Standard Day + 27°F (STD + 15°C), Dry Runway: Model 737-900/-900W (CFM56-7B24/-7B26 Engines at 24,000 LB SLST)**

**DO NOT USE FOR DISPATCH**  
**Takeoff Runway Length Requirements**  
**737-900/-900W (CFM56-7B24/-7B26)**

- NON-WINGLET PERFORMANCE SHOWN. WINGLET AIRCRAFT WILL HAVE SLIGHTLY IMPROVED PERFORMANCE.  
 - CONSULT USING AIRLINE FOR SPECIFIC OPERATING PROCEDURE PRIOR TO FACILITY DESIGN.

DRY RUNWAY  
 ZERO WIND  
 ZERO RUNWAY GRADIENT  
 AIR CONDITIONING OFF  
 OPTIMUM FLAP SETTING

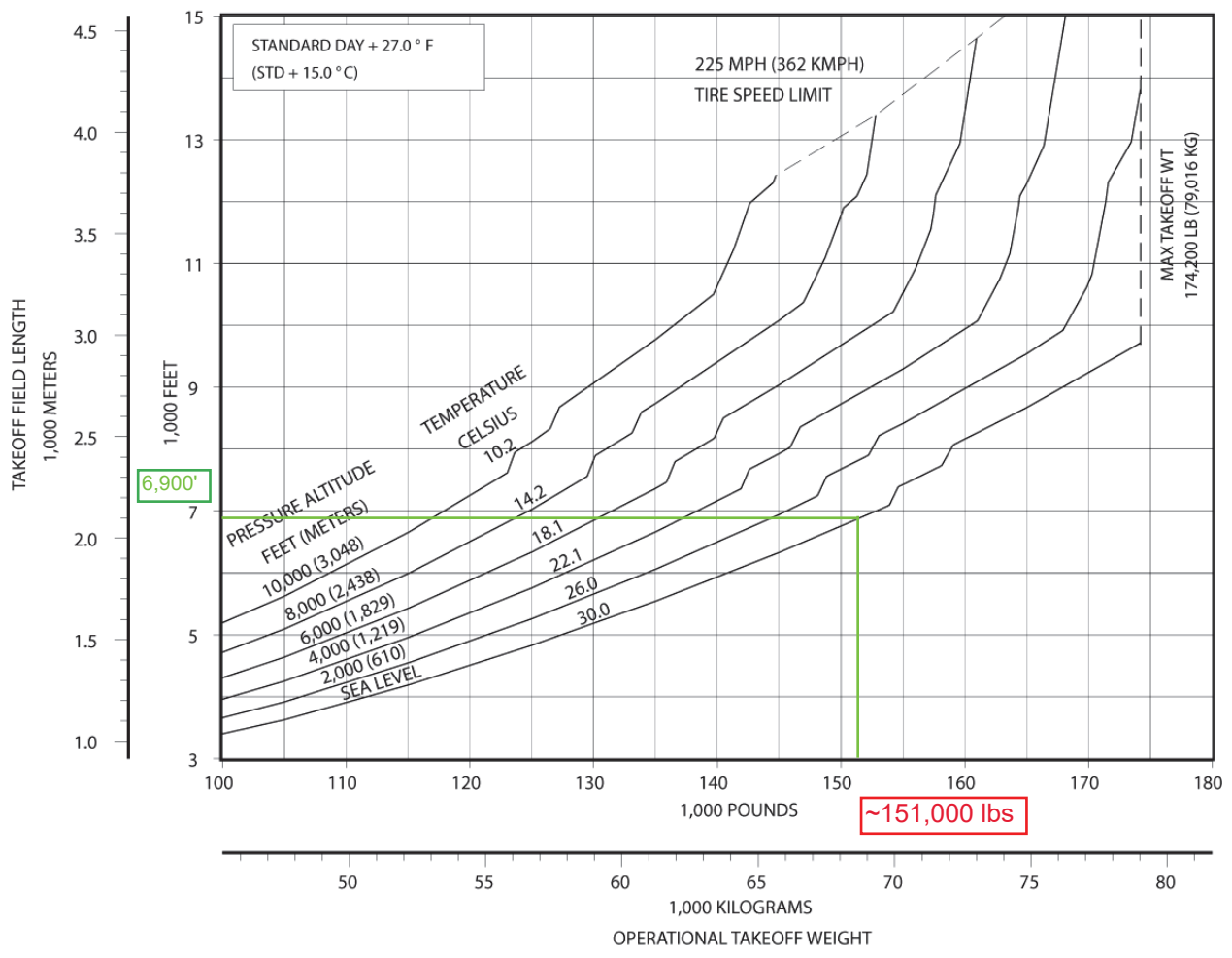

**3.3.60 F.A.R. Takeoff Runway Length Requirements - Standard Day + 27°F (STD + 15°C), Dry Runway: Model 737-900ER/-900ERW/BBJ3 (CFM56-7B26/-7B27 Engines at 26,000 LB SLST)**

**DO NOT USE FOR DISPATCH**

**Takeoff Runway Length Requirements  
737-900ER/-900ERW/BBJ3 (CFM56-7B26/-7B27)**

- NON-WINGLET PERFORMANCE SHOWN. WINGLET AIRCRAFT WILL HAVE SLIGHTLY IMPROVED PERFORMANCE.
- CONSULT USING AIRLINE FOR SPECIFIC OPERATING PROCEDURE PRIOR TO FACILITY DESIGN.

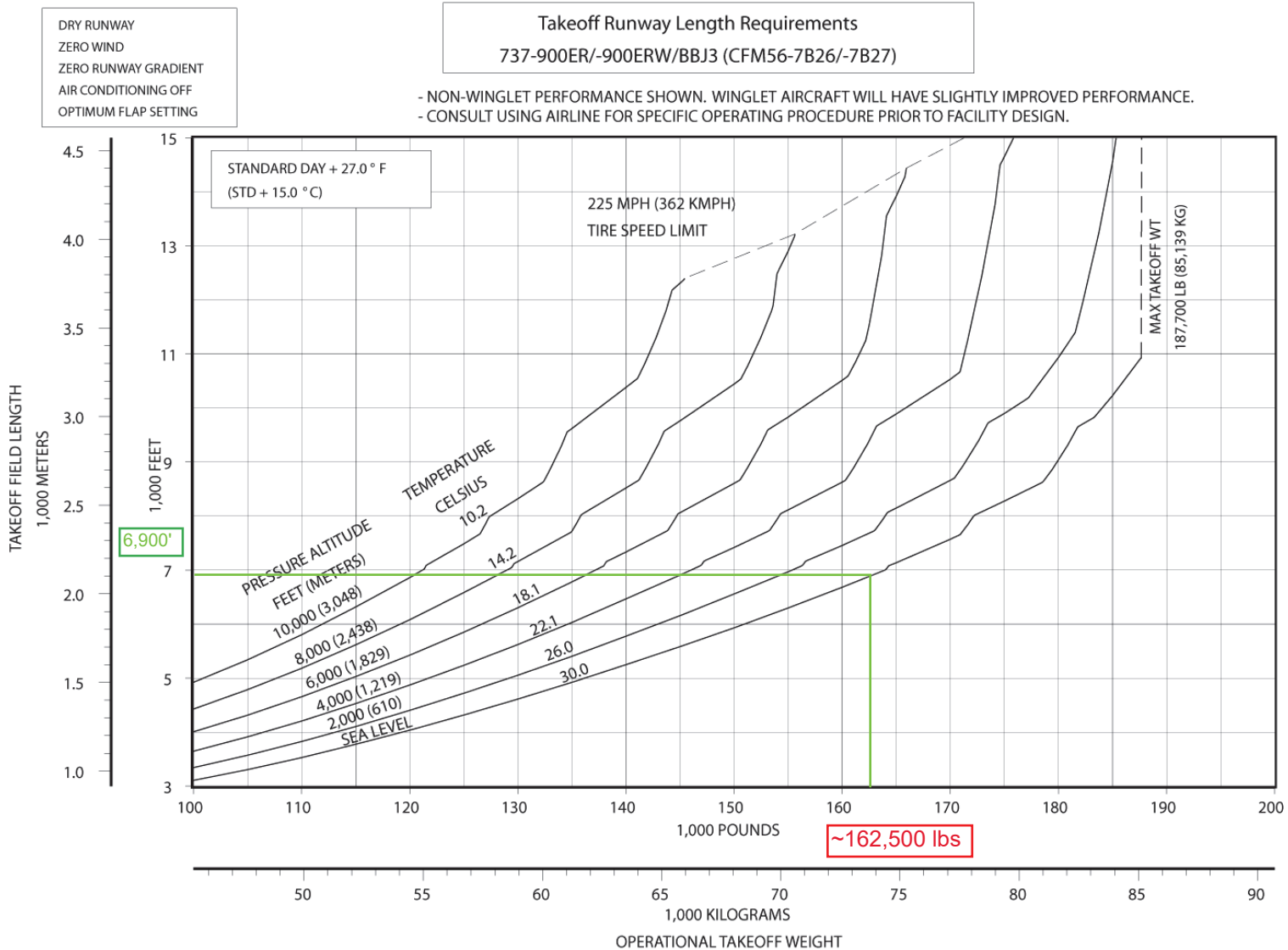

### 3.4.21 F.A.R. Landing Runway Length Requirements - Flaps 30: Model 737-800

DO NOT USE FOR DISPATCH

Landing Field Length  
737-800/-800W/BBJ2 (CFM56-7B Series)

- STANDARD DAY, ZERO WIND
- AUTO SPOILERS OPERATIVE
- ANTI-SKID OPERATIVE
- ZERO RUNWAY GRADIENT
- CONSULT USING AIRLINE FOR SPECIFIC OPERATING PROCEDURE PRIOR TO FACILITY DESIGN

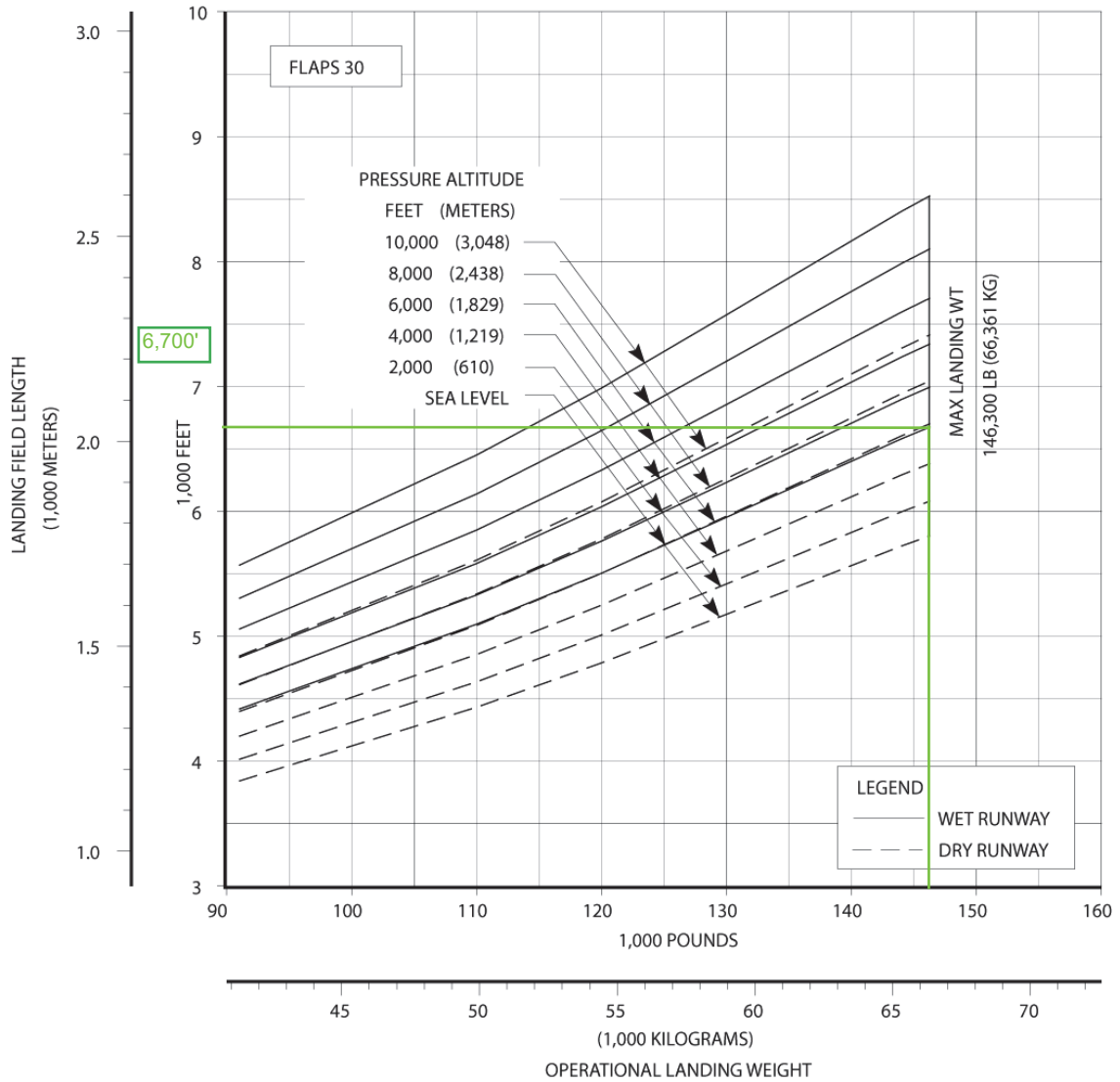

### 3.4.22 F.A.R. Landing Runway Length Requirements - Flaps 30: Model 737-900

DO NOT USE FOR DISPATCH

Landing Field Length  
737-900/-900W (CFM56-7B Series)

- STANDARD DAY, ZERO WIND
- AUTO SPOILERS OPERATIVE
- ANTI-SKID OPERATIVE
- ZERO RUNWAY GRADIENT
- CONSULT USING AIRLINE FOR SPECIFIC OPERATING PROCEDURE PRIOR TO FACILITY DESIGN

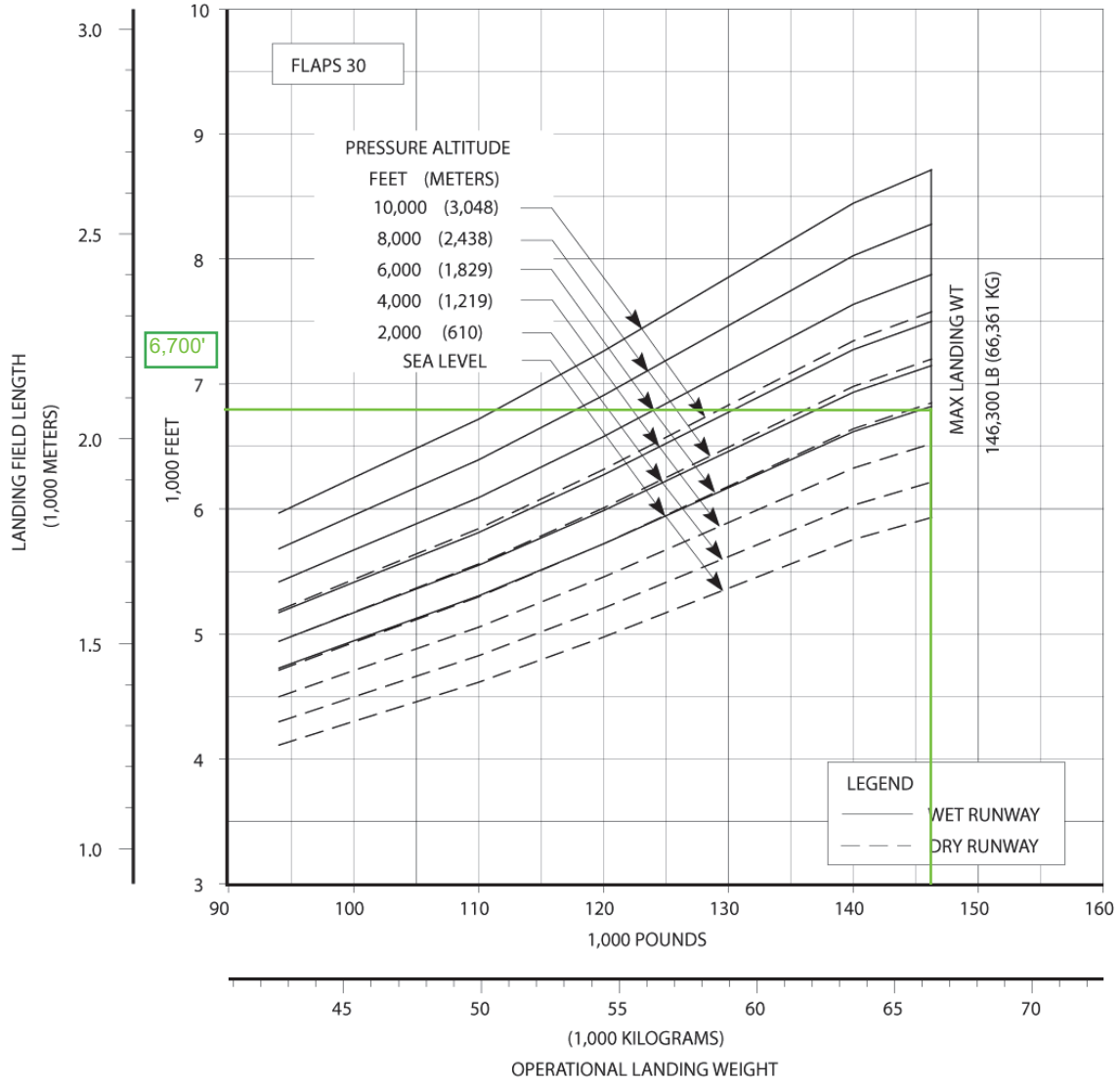

### 3.4.23 F.A.R. Landing Runway Length Requirements - Flaps 30: Model 737-900ER

DO NOT USE FOR DISPATCH

Landing Field Length  
737-900ER/-900ERW/BBJ3 (CFM56-7B Series)

- STANDARD DAY, ZERO WIND
- AUTO SPOILERS OPERATIVE
- ANTI-SKID OPERATIVE
- ZERO RUNWAY GRADIENT
- CONSULT USING AIRLINE FOR SPECIFIC OPERATING PROCEDURE PRIOR TO FACILITY DESIGN

